

<https://www.phoenixcontact.com/gb/products/1660944>

DIN rail mounting frame - HC-SMP 150-B24-AMQ - 1660944

Please be informed that the data shown in this PDF Document is generated from our Online Catalog. Please find the complete data in the user's documentation. Our General Terms of Use for Downloads are valid (<http://phoenixcontact.com/download>)



HEAVYCON DIN rail mounting frame with panel mounting base with double locking latch, for contact inserts of type B24, 150 mm long

RoHS

Key Commercial Data

Packing unit	5 pc
GTIN	 4 017918 022358
GTIN	4017918022358
Weight per Piece (excluding packing)	218.120 g
Custom tariff number	85389099
Country of origin	Germany
Note	Made to Order (non-returnable)

Technical data

Dimensions

Length	150 mm
Height	100 mm
Hole diameter	4.5 mm
Width	54 mm
Drill hole distance, horizontal	130 mm
Drill hole distance, vertical	32 mm

General

Note	for B24, BB48, BBB64, D40, DD108, and HV10 contact inserts
Type	B24

Drawings

DIN rail mounting frame - HC-SMP 150-B24-AMQ - 1660944

Dimensional drawing

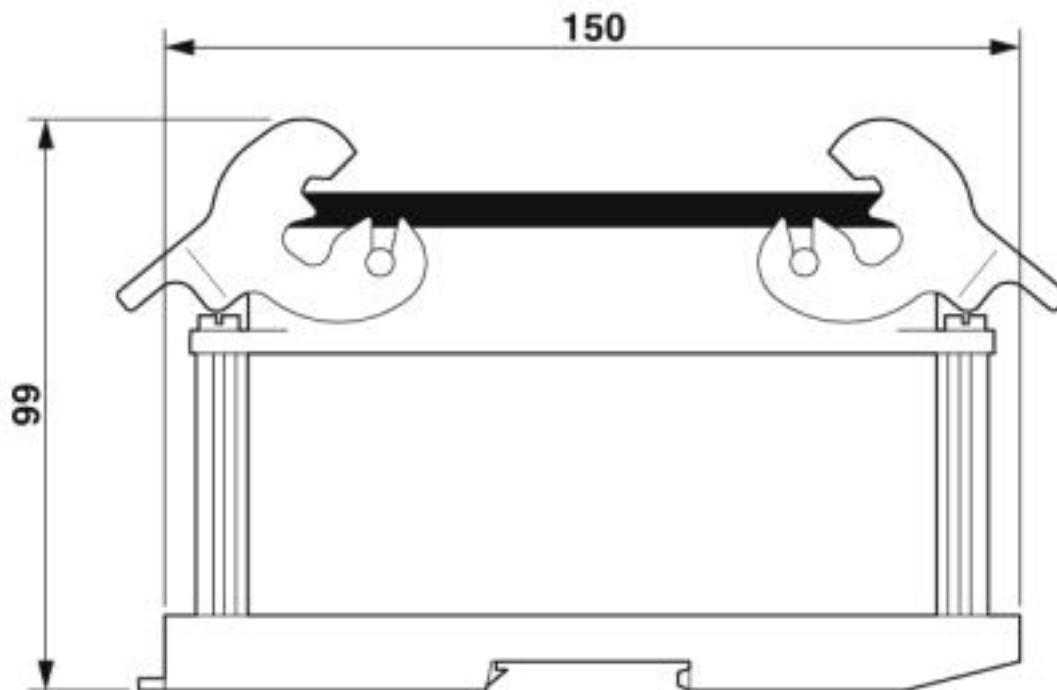

Classifications

eCl@ss

eCl@ss 4.0	27140816
eCl@ss 4.1	27140816
eCl@ss 5.0	27143424
eCl@ss 5.1	27143400
eCl@ss 6.0	27261200
eCl@ss 7.0	27440206
eCl@ss 8.0	27440206
eCl@ss 9.0	27440206

ETIM

ETIM 3.0	EC002310
ETIM 4.0	EC002310
ETIM 5.0	EC002312
ETIM 6.0	EC002312

UNSPSC

UNSPSC 6.01	43172601
UNSPSC 7.0901	39121416
UNSPSC 11	43172601
UNSPSC 12.01	39121408

<https://www.phoenixcontact.com/gb/products/1660944>

DIN rail mounting frame - HC-SMP 150-B24-AMQ - 1660944

Classifications

UNSPSC

UNSPSC 13.2	31261501
-------------	----------

Approvals

Approvals

Approvals

EAC

Ex Approvals

Approval details

EAC		RU C- DE.AI30.B.01102
-----	--	--------------------------

Phoenix Contact 2019 © - all rights reserved
<http://www.phoenixcontact.com>



SCATTERGOOD & JOHNSON LTD

ELECTRICAL ENGINEERING & FLUID CONTROL DISTRIBUTORS

Est.1899

At Scattergood & Johnson Ltd, we pride ourselves on being a technical distributor to specialist industries.

Working with a range of quality product suppliers across a number of specialist markets, we are not your average 'box shifter' - we are your technical and supply chain partner.

We fully support every product we sell - for free! Our internal team and external sales engineers can answer any product or application question, no matter the complexity.

Backing up this technical ability is a range of 50,000+ products available from stock for nationwide next day delivery (same day if required!), or you can collect what you need from any of our trade counters around the UK.

Select your specialist interest below to learn more about how we can help.



Online, In Branch and On the Road - Scattergood & Johnson Ltd, there when you need us.

www.scatts.co.uk