

<https://www.phoenixcontact.com/gb/products/2971535>

Base element - UMK-BE 11,25 - 2971535

Please be informed that the data shown in this PDF Document is generated from our Online Catalog. Please find the complete data in the user's documentation. Our General Terms of Use for Downloads are valid (<http://phoenixcontact.com/download>)

Electronic board base, plug-in module base element



Your advantages

- ✓ The modules can be marked using the marking grooves in the lateral element as well as with the Phoenix Contact PMB module marker, which is snapped into a bore hole (4 mm Ø) in the PCB
- ✓ Fast assembly thanks to the plug-in module principle. The tight engagement of the individual elements ensures that they are securely connected.
- ✓ Wide range of options for external conductor connection
- ✓ The mounting flange supports direct wall mounting
- ✓ Due to the universal foot, the modules can be snapped onto standard EN DIN rails

RoHS

Key Commercial Data

Packing unit	10 pc
Minimum order quantity	10 pc
GTIN	 4 017918 088392
GTIN	4017918088392
Weight per Piece (excluding packing)	4.720 g
Custom tariff number	85472000
Country of origin	Poland

Technical data

General

Housing type	Panel mounting base
Housing material	Polyamide
Color (RAL)	green

Ambient conditions

Ambient temperature (operation)	-40 °C ... 105 °C
---------------------------------	-------------------

Base element - UMK-BE 11,25 - 2971535

Technical data

Dimensions

Length	77 mm
Width	11.25 mm
Depth	77 mm

Standards and Regulations

Flammability rating according to UL 94	V2
--	----

Environmental Product Compliance

China RoHS	Environmentally friendly use period: unlimited = EFUP-e
	No hazardous substances above threshold values

Drawings

Dimensional drawing

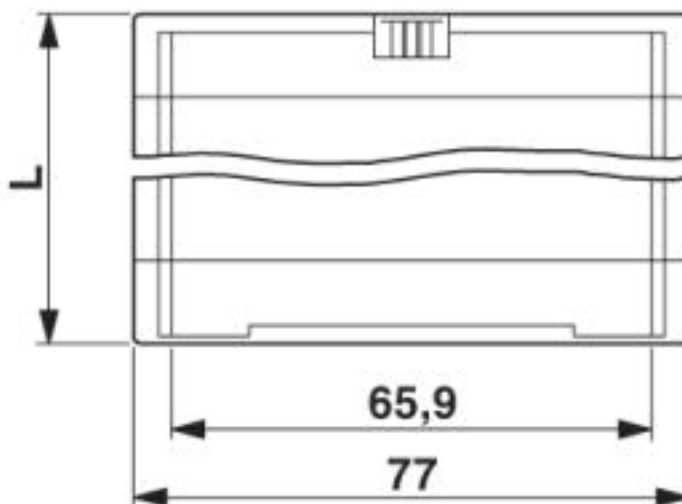
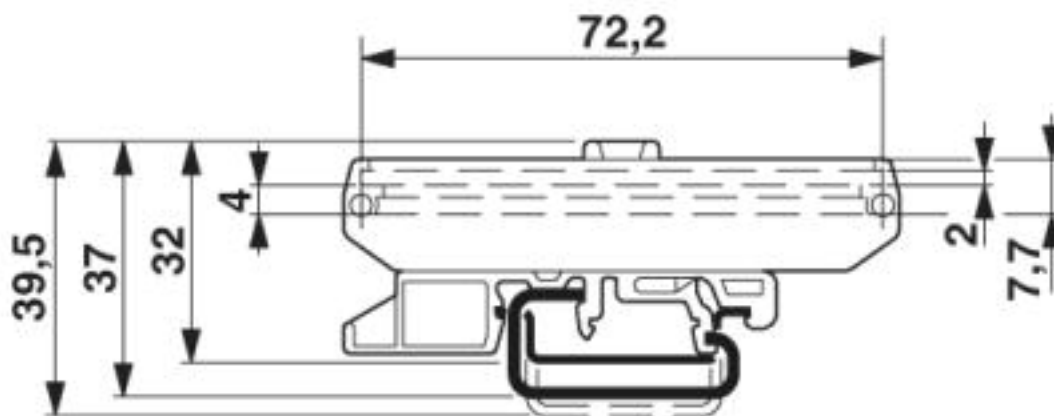

<https://www.phoenixcontact.com/gb/products/2971535>



Base element - UMK-BE 11,25 - 2971535

Classifications

eCl@ss

eCl@ss 4.0	27180400
eCl@ss 4.1	27180400
eCl@ss 5.0	27180500
eCl@ss 5.1	27180500
eCl@ss 6.0	27180800
eCl@ss 7.0	27182701
eCl@ss 8.0	27182701
eCl@ss 9.0	27182701

ETIM

ETIM 2.0	EC001031
ETIM 3.0	EC001031
ETIM 4.0	EC001031
ETIM 5.0	EC002779
ETIM 6.0	EC002779
ETIM 7.0	EC002779

UNSPSC

UNSPSC 6.01	31261501
UNSPSC 7.0901	31261501
UNSPSC 11	31261501
UNSPSC 12.01	31261501
UNSPSC 13.2	31261501

Approvals

Approvals

Approvals

UL Recognized / EAC

Ex Approvals

Approval details

UL Recognized		http://database.ul.com/cgi-bin/XYVV/template/LISEXT/1FRAME/index.htm	FILE E 240868
---------------	---	---	---------------

<https://www.phoenixcontact.com/gb/products/2971535>



Base element - UMK-BE 11,25 - 2971535

Approvals

EAC	The EAC (Euro-Asian Conformity) logo, consisting of the letters 'EAC' in a bold, stylized font.	B.01742
-----	---	---------

Phoenix Contact 2019 © - all rights reserved
<http://www.phoenixcontact.com>



SCATTERGOOD & JOHNSON LTD

ELECTRICAL ENGINEERING & FLUID CONTROL DISTRIBUTORS

Est.1899

At Scattergood & Johnson Ltd, we pride ourselves on being a technical distributor to specialist industries.

Working with a range of quality product suppliers across a number of specialist markets, we are not your average 'box shifter' - we are your technical and supply chain partner.

We fully support every product we sell - for free! Our internal team and external sales engineers can answer any product or application question, no matter the complexity.

Backing up this technical ability is a range of 50,000+ products available from stock for nationwide next day delivery (same day if required!), or you can collect what you need from any of our trade counters around the UK.

Select your specialist interest below to learn more about how we can help.



Online, In Branch and On the Road - Scattergood & Johnson Ltd, there when you need us.

www.scatts.co.uk