

PSI-REP-DNET CAN

DeviceNet

CANopen



Repeater for CAN-based systems up to 1 Mbps

Data sheet
104297_en_02

© PHOENIX CONTACT 2016-07-07

1 Description

The **PSI-REP-DNET CAN** modular CAN repeater is designed to meet the high requirements of high-performance CAN networks. The repeater can be used in all networks that meet the CANopen[®], DeviceNet[™], and SDS standards.

The device is snapped onto standard DIN rails in the control cabinet and supplied with 24 V DC.

Possible applications:

- Electrical isolation and bus segmentation
- Increasing system availability
- Increasing the range
- Increasing the transmission speed
- Extending the number of devices to n x 64 per potential segment
- Structure for line, star, and tree structures

Features

- Data rates of up to 1 Mbps
- Automatic data rate detection
- Electrical isolation between CAN interface, supply, and DIN rail connector
- Bit retiming for unrestricted cascading of devices
- Integrated surge protection with transient discharge to the DIN rail
- Can be combined with PSI-MOS FO converters in a modular way using DIN rail connectors



WARNING: Explosion hazard when used in potentially explosive areas

The device is a category 3 item of electrical equipment. Follow the instructions provided here during installation and observe the safety notes.



Make sure you always use the latest documentation.
It can be downloaded from the product at phoenixcontact.net/products.

2	Table of contents	
1	Description	1
2	Table of contents	2
3	Ordering data	3
4	Technical data	4
5	Safety regulations and installation notes.....	7
	5.1 Installation and operation.....	7
	5.2 Safety regulations for installation in potentially explosive areas	7
6	Application examples	8
	6.1 Bit retiming.....	9
7	Structure	10
	7.1 Dimensions	10
	7.2 Block diagram.....	10
	7.3 Function elements	11
	7.4 Diagnostics and status indicators.....	12
	7.5 Termination resistor.....	12
8	Configuration via DIP switches	13
	8.1 Set the data rate (DIP switches 1 - 4)	13
	8.2 Set the operating mode (DIP switch 5)	13
9	Assembly	14
	9.1 Mounting on a DIN rail	14
	9.2 Combined assembly.....	14
	9.3 Removal.....	14
10	Supply voltage	15
	10.1 Operation as a single device.....	15
	10.2 Operation in a topology	15
11	CAN interfaces	16
12	Switching output	16

3 Ordering data

Description	Type	Order No.	Pcs./Pkt.
Modular repeater for electrical isolation and increasing the range for DeviceNet/SDS/CANopen, data rate of up to 1 Mbps. High-quality electrical isolation between the interfaces, DIN-rail mountable, 24 V DC supply.	PSI-REP-DNET CAN	2313423	1
Accessories	Type	Order No.	Pcs./Pkt.
Primary-switched MINI POWER supply for DIN rail mounting, input: 1-phase, output: 24 V DC/1.5 A	MINI-SYS-PS-100-240AC/ 24DC/1.5	2866983	1
DIN rail connector for DIN rail mounting. Universal for TBUS housing. Gold-plated contacts, 5-pos. Header, Nominal current: 8 A, Number of positions: 5, Pitch: 3.81 mm, Articles with gold-plated contacts, bus connectors for connecting with electronic housings	ME 17,5 TBUS 1,5/ 5-ST-3,81 GN	2709561	10
Bus system cable, CANopen®, DeviceNet™, 4-position, PUR halogen-free, violet RAL 4001, shielded, Cable length: Free entry (0.5 ... 400.0 m)	SAC-5P-920/...	1511504	1
D-SUB plug, 9-pos., socket, with PG-D-SUB pin, assignment: 2, 3, 5, 6, 7, 9; two M12 cable glands (A-coded) under 90°. Bus system: CAN, CANopen®. Termination resistor via separate M12 terminator.	SUBCON-PLUS-CAN/90/PG/ M12	2902322	1
D-SUB plug, 9-pos., socket, assignment: 2, 3, 5, 6, 7, 9; two M12 cable glands (A-coded) under 90°. Bus system: CAN, CANopen®. Termination resistor via separate M12 terminator.	SUBCON-PLUS-CAN/90/ M12	2902323	1
D-SUB plug, 9-pos., socket, with PG-D-SUB pin, assignment: 2, 3, 5, 6, 7, 9; two M12 cable glands (A-coded) under 35°. Bus system: CAN, CANopen®. Termination resistor via separate M12 terminator.	SUBCON-PLUS-CAN/35/PG/ M12	2902324	1
D-SUB plug, 9-pos., socket, assignment: 2, 3, 5, 6, 7, 9; two M12 cable glands (A-coded) under 35°. Bus system: CAN, CANopen®. Termination resistor via separate M12 terminator.	SUBCON-PLUS-CAN/35/ M12	2902325	1
D-SUB plug, 9-pos., socket, assignment: 2, 3, 5, 6, 7, 9; two M12 cable glands (A-coded) under 180° (axial). Bus system: CAN, CANopen®. Termination resistor via separate M12 terminator.	SUBCON-PLUS-CAN/AX/ M12	2902326	1

Accessories	Type	Order No.	Pcs./Pkt.
D-SUB connector, 9-pos. female connector, two cable entries < 35° to one terminal block row, bus system: CAN, CANopen®, SafetyBUS p up to 1 Mbps, termination resistor can be switched on via slide switch, pin assignment: 2, 3, 7; screw connection terminal blocks	SUBCON-PLUS-CAN	2744694	1
D-SUB connector, 9-pos. socket, cable entry < 35°, bus system: CAN, CANopen®, SafetyBUS p up to 1 Mbps, with PG D-SUB socket for connecting a programming device, termination resistor can be switched on via slide switch, pin assignment: 2, 3, 7, 9; screw terminal blocks	SUBCON-PLUS-CAN/PG	2708119	1
D-SUB connector, 9-pos. female connector, axial version with two cable entries, bus system: CAN, CANopen, SafetyBUS p; pin assignment: 2, 3, 7; screw connection terminal blocks	SUBCON-PLUS-CAN/AX	2306566	1

4 Technical data

Supply	
Supply voltage range	10 V DC ... 30 V DC (via pluggable COMBICON screw terminal block)
Nominal supply voltage	24 V DC
Typical current consumption	55 mA (24 V DC)
Max. current consumption	80 mA
Electrical isolation	VCC // TBUS // CAN A // CAN B
Test voltage data interface/power supply	1.5 kV _{rms} (50 Hz, 1 min.)
Torque	0.56 Nm ... 0.79 Nm
CAN interface, in accordance with ISO/IS 11898 for DeviceNet, CAN, CANopen	
No. of channels	2 (CAN_High / CAN_Low)
Operating mode	Semi-duplex
Transmission method	CSMA/CA
Connection method	COMBICON plug-in screw terminal block
Conductor cross section	0.2 mm ² ... 2.5 mm ² (24 AWG ... 14 AWG)
Data format/encoding	Bit stuffing, NRZ
Termination resistor	124 Ω
Transmission speed	≤ 1 MBit/s (Configurable via DIP switches)
Transmission length	≤ 5000 m (Dependent on the data rate and the protocol used)
Transmission medium	2-wire twisted pair, shielded
Number of bus devices	≤ 64 (per potential segment) ≤ 63 (DeviceNet™, can be addressed logically) ≤ 128 (CANopen®, can be addressed logically)
Status and diagnostic indicators	LEDs: VCC (supply voltage), NET A (Mod/Net status port A), NET B (Mod/Net status port B), ACT (activity/data traffic)

Relay output	
Number of outputs	1
Contact type	N/O contact
Minimum switching voltage	10 V DC
Maximum switching voltage	30 V DC
Limiting continuous current	500 mA
General data	
Degree of protection	IP20
Dimensions (W/H/D)	35 mm x 111 mm x 121 mm
Housing material	PA 6.6-FR green
Free fall in acc. with IEC 60068-2-32	1 m
Vibration resistance in acc. with EN 60068-2-6/ IEC 60068-2-6	5g, 10-150 Hz, 2.5 h, in XYZ direction
Shock in acc. with EN 60068-2-27/IEC 60068-2-27	15g, 11 ms period, half-sine shock pulse
MTTF (mean time to failure) SN 29500 standard, temperature 25 °C, operating cycle 21 % (5 days a week, 8 hours a day)	1091 Years
MTTF (mean time to failure) SN 29500 standard, temperature 40 °C, operating cycle 34.25 % (5 days a week, 12 hours a day)	514 Years
MTTF (mean time to failure) SN 29500 standard, temperature 40 °C, operating cycle 100 % (7 days a week, 24 hours a day)	208 Years
Bit distortion, input	± 35 %
Bit distortion, output	< 6.25 %
Bit delay in standard operation	≤ 1 Bit (FAST)
Bit delay	One telegram length (EXTENDED)
Noise emission according to	EN 55011
Noise immunity according to	EN 61000-6-2
Electromagnetic compatibility	Conformance with EMC Directive 2014/30/EU
Ambient conditions	
Ambient temperature (operation)	-20 °C ... 60 °C
Ambient temperature (storage/transport)	-40 °C ... 85 °C
Permissible humidity (operation)	30 % ... 95 % (non-condensing)
Altitude	5000 m (For restrictions see manufacturer's declaration)
Approvals / Certificates	
Conformance	CE-compliant EAC
Free from substances that could impair the application of coating	according to P-VW 3.10.7 57 65 0 VW-AUDI-Seat central standard
ATEX Please follow the special installation instructions in the documentation!	⊕ II 3 G Ex nA IIC T4 Gc X

Approvals / Certificates

UL, USA/Canada	508 listed
Standards/regulations	DIN EN 50178, DIN EN 60950
Shipbuilding approval	DNV

Conformance with EMC Directive 2014/30/EU**Noise immunity according to EN 61000-6-2**

Electrostatic discharge	EN 61000-4-2	
	Contact discharge	± 6 kV
	Discharge in air	± 8 kV
	Comments	Criterion B
Electromagnetic HF field	EN 61000-4-3	
	Frequency range	80 MHz ... 3 GHz
	Field intensity	10 V/m
	Comments	Criterion A
Fast transients (burst)	EN 61000-4-4	
	Input	± 2 kV
	Signal	± 2 kV
	Comments	Criterion B
Surge current loads (surge)	EN 61000-4-5	
	Input	± 0.5 kV
	Signal	± 1 kV
	Comments	Criterion B
Conducted interference	EN 61000-4-6	
	Voltage	10 V
	Comments	Criterion A

Emitted interference in acc. with EN 61000-6-4

Interference emission	EN 55011 Class A, industrial applications
-----------------------	--

Criterion A Normal operating behavior within the specified limits

Criterion B Temporary impairment of operating behavior that is corrected by the device itself

**INDUSTRIAL CONTROL EQUIPMENT 11AE**

Wire Range: 24-14 AWG

Torque: 5-7 (Lbs-Ins)

Environmental designation: "Open Type Device"

"Pollution Degree 2 Installation Environment"

5 Safety regulations and installation notes

5.1 Installation and operation



CAUTION:

Observe the following safety notes when using the repeater.

- The category 3 device is designed for installation in zone 2 potentially explosive areas. It meets the requirements of EN 60079-0:2012+A11:2013 and EN 60079-15:2010.
- Installation, operation, and maintenance may only be carried out by qualified electricians. Follow the installation instructions as described.
- When installing and operating the device, the applicable regulations and safety directives (including national safety directives), as well as general technical regulations, must be observed. The technical data is provided in the package slip and on the certificates (conformity assessment, additional approvals where applicable).
- The device must not be opened or modified apart from the configuration of the DIP switches. Do not repair the device yourself but replace it with an equivalent device. Repairs may only be carried out by the manufacturer. The manufacturer is not liable for damage resulting from a failure to comply.
- The IP20 protection (IEC 60529/EN 60529) of the device is intended for use in a clean and dry environment. The device must not be subject to mechanical strain and/or thermal loads, which exceed the limits described.
- The device is not designed for use in atmospheres with a danger of dust explosions.
- The switches of the device that can be accessed may only be actuated when the power supply to the device is disconnected.
- The device is designed exclusively for SELV operation according to IEC 60950/EN 60950/VDE 0805. The device may only be connected to devices, which meet the requirements of EN 60950.

5.2 Safety regulations for installation in potentially explosive areas



WARNING: Explosion hazard when used in potentially explosive areas

Please make sure that the following notes and instructions are observed.

- Observe the specified conditions for use in potentially explosive areas.
- At the time of installation, use an approved housing (minimum protection IP54), which meets the requirements of EN 60079-15. Within this context, observe the requirements of IEC 60079-14/EN 60079-14.
- In zone 2, only connect devices to the supply and signal circuits that are suitable for operation in the Ex zone 2 and the conditions at the installation location.
- In potentially explosive areas, terminals may only be snapped onto or off the DIN rail connector and wires may only be connected or disconnected when the power is switched off.
- The device must be stopped and immediately removed from the Ex area if it is damaged, was subject to an impermissible load, stored incorrectly or if it malfunctions.

6 Application examples

The repeater can be used to create network structures that are tailored to the relevant application.

The basic limits are specified by the CAN standard and the electrical properties of the CAN network. Please note the following basic specifications:

- Up to 64 devices per potential segment, depending on the protocol and the bus drivers used
- Only line structures
- Maximum length of a bus line: 1000 m, depending on the protocol and the bus drivers used
- Bus cable termination at the start and end of the bus cable



Please note that in each potential segment, the port of the repeater must be considered as an electrical device.

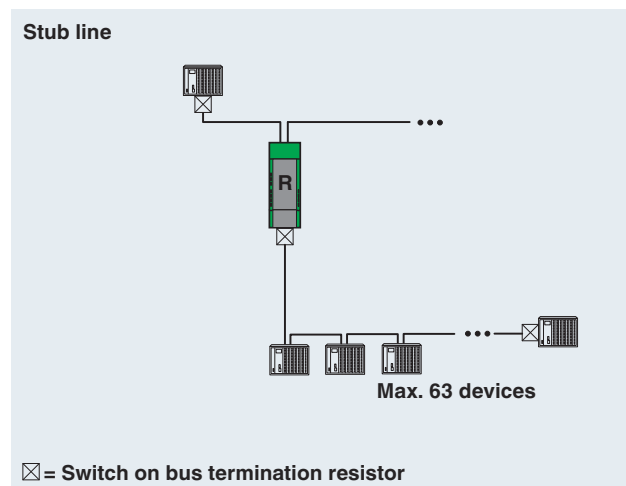

Figure 1 Branch line

A segment can be created as an active branch, which can comprise the full bus cable length and a maximum of 63 devices.

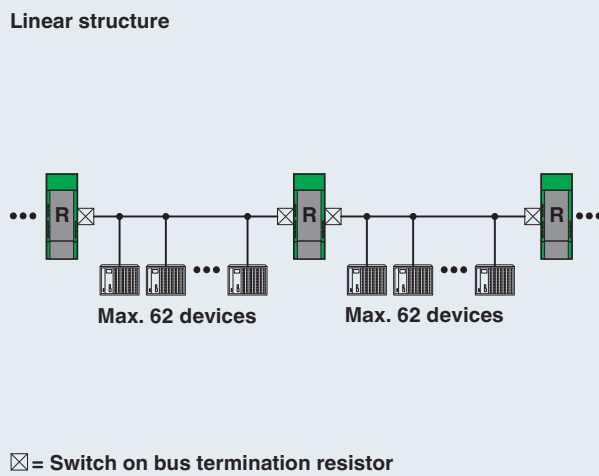

Figure 2 Line structure

Bus segmentation with repeaters makes it possible to multiply the permissible coverage of the network and to extend the number of devices.

The full number of devices applies in each potential segment.

Higher transmission speeds can also be supported by subdividing into shorter segment lengths.

Example: normally, a CAN system with a length of 500 m could only be operated at a data rate of 125 kbps. If you use a repeater after 100 m, the possible data rate is 500 kbps.

It makes sense to limit the number of devices in a potential segment to 63, since there are many different suppliers of CAN-compatible devices. Please note that the port of a repeater must also be considered as an electrical device without address.

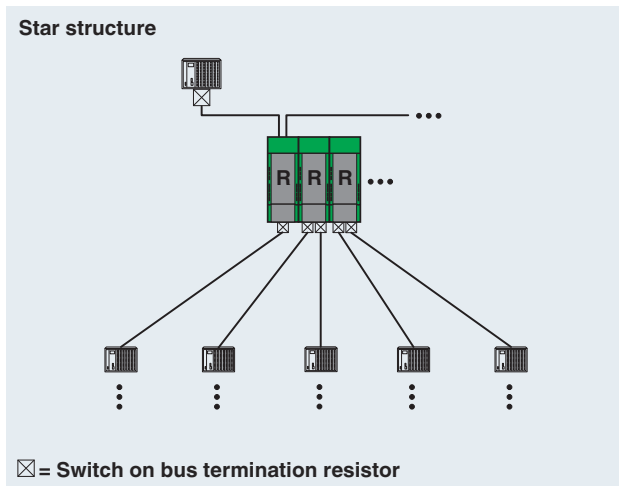

Figure 3 Star structure

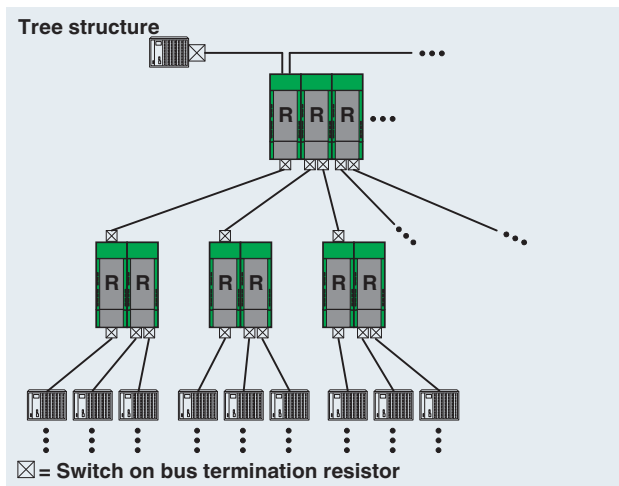

Figure 4 Tree structure

Mixed/network structures, star, and tree structures can be created using the repeaters. The repeaters can be extended using PSI-MOS-DNET CAN... fiber optic converters.

In addition, the repeaters can be combined and therefore configured to form a modular CAN hub.

6.1 Bit retiming

CAN signals with bit distortion can be reliably detected using the bit retiming function (only in “Extended” mode) and are converted to their original bit form before being transferred to the next segment.

This data processing function means that a virtually unlimited number of repeaters can be connected without an impermissible level of bit distortion.

Observe the system timing specifications when using several connected repeaters.

7 Structure

7.1 Dimensions

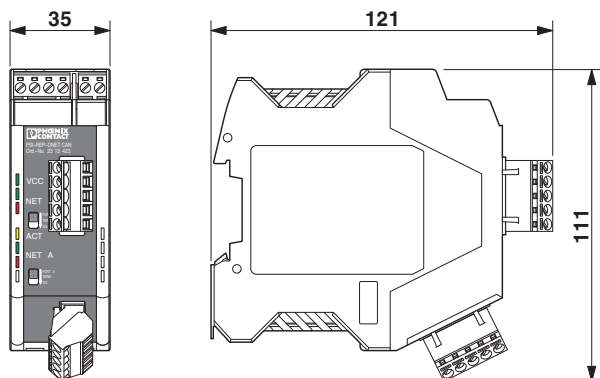

Figure 5 Housing dimensions

7.2 Block diagram

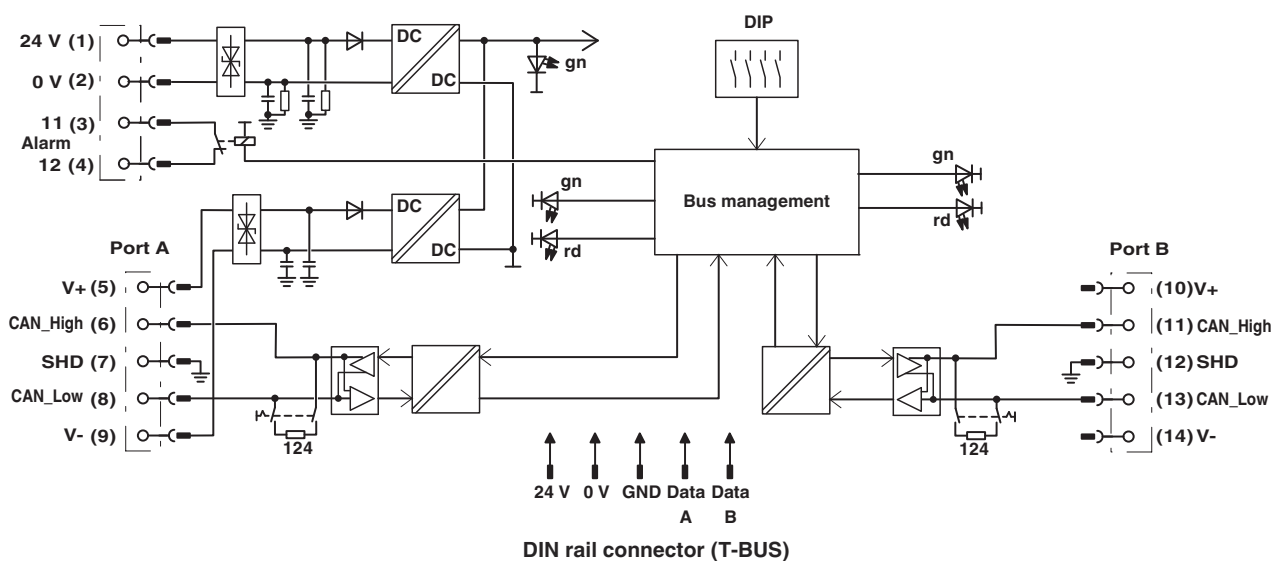

Figure 6 Block diagram

7.3 Function elements

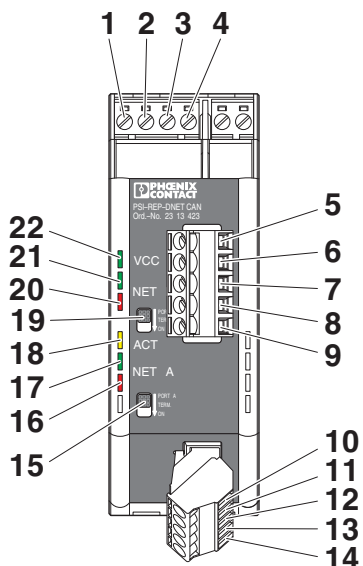

Figure 7 Function elements

- | | | | |
|----|------------------------|---------------|---------------------------------------|
| 1 | 24 V DC supply voltage | | |
| 2 | 0 V DC supply voltage | | |
| 3 | N/C contact | Connection 11 | |
| 4 | N/C contact | Connection 12 | |
| 5 | CAN_V+ | Port B | Red 24 V DC |
| 6 | CAN_H | Port B | White CAN_High:
Data signal |
| 7 | CAN_SHLD | Port B | Cable shield |
| 8 | CAN_L | Port B | Blue CAN_Low:
Inverted data signal |
| 9 | CAN_V- | Port B | Black GND |
| 10 | CAN_V+ | Port A | Red 24 V DC |
| 11 | CAN_H | Port A | White CAN_High:
Data signal |
| 12 | CAN_SHLD | Port A | Cable shield |
| 13 | CAN_L | Port A | Blue CAN_Low:
Inverted data signal |
| 14 | CAN_V- | Port A | Black GND |
| 15 | Switch | Port A | Termination resistor |
| 16 | LED | NET A | Red |
| 17 | LED | NET A | Green |
| 18 | LED | ACT | |
| 19 | Switch | Port B | Termination resistor |
| 20 | LED | NET B | Red |
| 21 | LED | NET B | Green |
| 22 | LED | VCC | |

7.4 Diagnostics and status indicators

LED indicators for copper interfaces

One green and one red LED indicate the status of the copper interface.

If the device does not behave as expected, use the following table to check the meaning of the status indicators.

NET A/B					
Green LED	Red LED	VCC	Meaning	Switching output	Corrective
OFF	OFF	-	No supply voltage	Activated	Check the connected supply voltage.
ON	OFF	-	Device ready to operate, connection present, telegrams are being detected reliably	Not activated	Device is operating correctly.
Flashing	OFF	Flashing (autobaud)	Device ready to operate, no connection (e.g. data rate not detected)	Activated	Check connected data cables to ensure the connection and polarity are correct. Check the data rate set via the DIP switches. Check the connected master and its bus parameters (e.g. data rate).
Flashing	OFF	On (manual)		Not activated	
ON	Flashing	-	Temporary error, CAN diagnostics indicate sporadically damaged telegrams	Not activated	Check connected data cables to ensure the connection and polarity are correct. Check the network termination.
OFF	ON	-	Critical error (bus OFF), telegram traffic no longer supported, port faulty	Activated	Check the connected master and its bus parameters (e.g. timing). Check the network and supply voltage for coupled interference

CAN interface

18	ACT	Flashing	Activity at the ports and/or the backplane (no evaluation of valid telegrams)
		OFF	No activity at the ports and/or the backplane (no evaluation of valid telegrams)

Supply voltage

22	VCC	ON	Supply voltage OK
		Flashing	Supply voltage present but no valid data rate detected ("Autobaud" setting only)
		OFF	No supply voltage.

7.5 Termination resistor

If using the repeater at the start or end of a segment, the integrated termination resistors must be activated.

- Set the relevant slide switch on the front of the device (15 or 19) to "ON".



Make sure that the termination resistors are only activated at the start and end of a copper segment.

8 Configuration via DIP switches



NOTE: electrostatic discharge!

The device contains components that can be damaged or destroyed by electrostatic discharge. When handling the device, observe the necessary safety precautions against electrostatic discharge (ESD) according to EN 61340-5-1 and IEC 61340-5-1.



Only select the mode of operation when the power is disconnected! The change is activated after renewed power up.

The DIP switches for configuration are located under the cover on the port B interface.

- Insert a small screwdriver into the slot on the bottom of the cap and remove the cap.

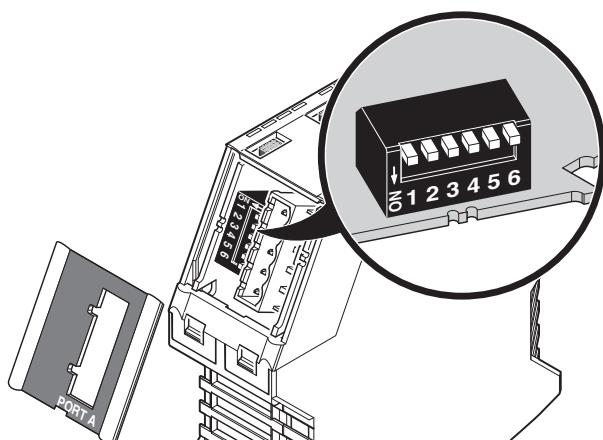

Figure 8 DIP switches

At delivery, all DIP switches are in the "OFF" position. DIP switch 6 has no function.

8.1 Set the data rate (DIP switches 1 - 4)

- Set the transmission speed using the DIP switches.



Set all connected CAN devices to the same data rate.

ON = •	DIP 1	DIP 2	DIP 3	DIP 4
Data rate [kbps]				
Autobaud				
1000	•			
800		•	•	•
500		•	•	
250		•		•
125		•		
50			•	•
20			•	
10				•

8.2 Set the operating mode (DIP switch 5)

Operating mode	DIP 5
Extended	OFF
Fast	ON

"Extended Network" (DIP 5 = OFF): Ports A and B support the maximum segment length, which depends on the set data rate. The internal bus management is activated, the bit retiming is available. The bit delay in the device is due to a telegram runtime (depending on the type of telegram, between 44 and 108 bits).

This operating mode is suitable for physically extensive networks with moderate response times.

"Fast" (DIP 5 = ON): Internal bus management is deactivated. When the bit delay is < 1 bit, both as stand-alone device and grouped (modular star coupler), the total size of the network is reduced across all segments. Only electrical isolation and signal amplification occurs between the ports.

This operating mode is suitable for small networks with fast response times.

- Stand-alone means that a single repeater is operated. No other devices are connected via the DIN rail connector.
- Modular means that several repeaters are connected together via the DIN rail connector. This structure is also referred to as a star distributor or modular CAN hub.



In a modular topology, all the devices must be set to the same operating mode.

For all devices, port A and the backplane (DIN rail connector) are connected together directly in terms of data using a dedicated repeater function (electrical isolation and signal amplification).

9 Assembly



CAUTION: Electric shock

The device is designed exclusively for SELV operation according to IEC 60950/EN 60950/VDE 0805. The device may only be connected to devices, which meet the requirements of EN 60950.



NOTE: Malfunction

Use a grounding terminal block to connect the DIN rail to protective earth ground. The devices are grounded when they are snapped onto the DIN rail (installation according to PELV).

This ensures that the shielding is effective. Connect protective earth ground with low impedance.

9.1 Mounting on a DIN rail

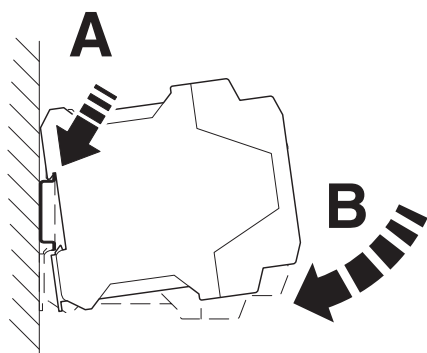

Figure 9 Mounting on a DIN rail

- To avoid contact resistance, only use clean, corrosion-free 35 mm DIN rails according to DIN EN 60715.
- Install an end bracket next to the left-hand device to prevent the devices from slipping.
- Place the device onto the DIN rail from above. Push the module from the front toward the mounting surface until it audibly engages.
- Snap the other devices that are to be contacted onto the DIN rail next to one another.

9.2 Combined assembly



A connection station must not consist of more than ten devices.

Observe the snap-in direction of the device and DIN rail connector: snap-on foot below and plug on the left.

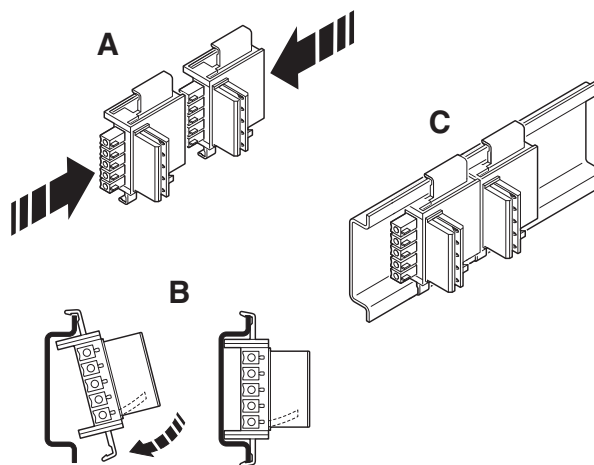

Figure 10 Combined assembly

The DIN rail connector is used to bridge the power supply and communication.

- For one connection station, plug the DIN rail connectors together (order no. 2709561, 2 per device).
- Push the connected DIN rail connectors into the DIN rail.
- Place the device onto the DIN rail from above. Push the module from the front toward the mounting surface until it audibly engages.

9.3 Removal

- Push down the locking tab with a screwdriver, needle-nose pliers or similar.
- Slightly pull the bottom edge of the device away from the mounting surface.
- Pull the device away from the DIN rail.

When you dismantle a connection station, also remove the DIN connectors.

10 Supply voltage

The device is operated using a 24 V DC SELV.

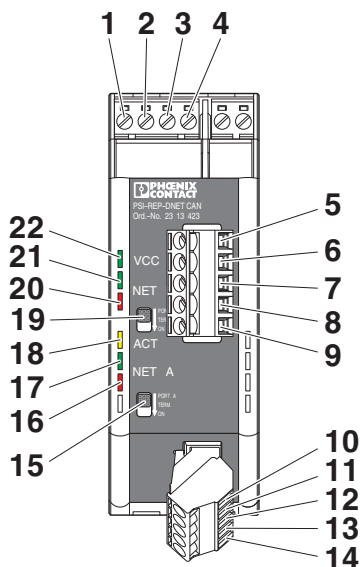

- 1 24 V DC supply voltage
- 2 0 V DC supply voltage

10.1 Operation as a single device

- Supply voltage to the device via terminal blocks **1** (24 V) and **2** (0 V).

Optional supply via port A:

Use a hybrid cable in order to transmit data and a supply voltage. An additional power supply via terminals **1** and **2** is not necessary. The supply voltage is not forwarded via the DIN rail connector.

10.2 Operation in a topology



NOTE: device damage

The maximum current load in a connection station must not exceed 2 A.

A connection station must not consist of more than ten devices.

When the devices are operated in a topology, the supply voltage must only be supplied to the first device in the station. The remaining devices are supplied via the DIN rail connector.

Supply via port A or port B is not supported.

A second power supply unit can be used to create a redundant supply concept.

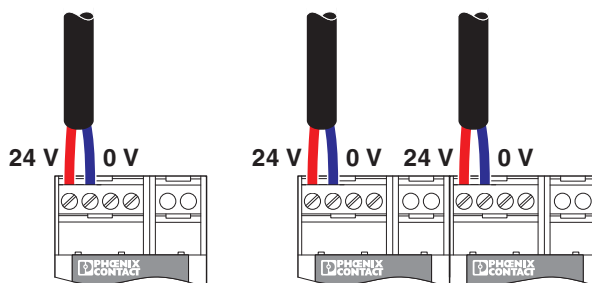

Figure 11 Individual/redundant supply

Using the system current supply

Alternatively, the connection station can be connected to a system power supply.

- Connect a system power supply to two DIN rail connectors on the left of the group. (MINI-SYS-PS-100-240AC/24DC/1.5, Order No. 2866983 or MINI-PS100-240AC/24DC/1.5/EX, Order No. 2866653 and two DIN rail connectors, Order No. 2709561)

11 CAN interfaces



NOTE: Interference
Use shielded twisted pair data cables. Connect the cable shielding at both ends of the transmission path.

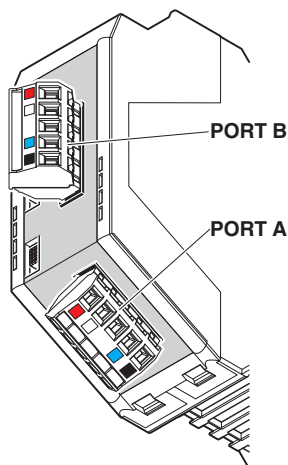

Figure 12 CAN interfaces

- If the device is at the start or end of a CAN segment, the termination resistors must be activated. Set the slide switch for port A or port B to "ON".

Assignment			
Pin	Color	Signal	Meaning
1	Black	V-	GND
2	Blue	CAN_L	CAN_Low: Inverted data signal
3	Clear	SHD	Cable shield
4	White	CAN_H	CAN_High: Data signal
5	Red	V+	24 V DC



The device cannot be supplied via port B.

12 Switching output



NOTE: device damage
The maximum load capacity of the relay contact is 60 V DC, 0.5 A.

The device is equipped with a floating switching output for error diagnostics (terminals 3 (11) and 4 (12)).

The switch contact opens on the relevant device in the event of a transmission error at port A or port B.

The switching output is an N/C contact. It can be connected to a local digital input, e.g., on a PLC, for error detection.

When mounted in a topology, the individual switching outputs can be connected to separate input points or the individual contacts can be looped through to generate a group message.

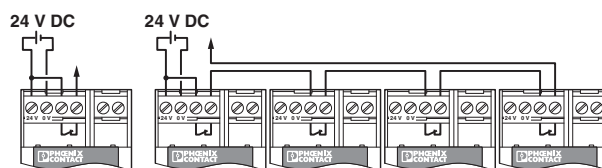

Figure 13 Individual and group message



SCATTERGOOD & JOHNSON LTD

ELECTRICAL ENGINEERING & FLUID CONTROL DISTRIBUTORS

Est.1899

At Scattergood & Johnson Ltd, we pride ourselves on being a technical distributor to specialist industries.

Working with a range of quality product suppliers across a number of specialist markets, we are not your average 'box shifter' - we are your technical and supply chain partner.

We fully support every product we sell - for free! Our internal team and external sales engineers can answer any product or application question, no matter the complexity.

Backing up this technical ability is a range of 50,000+ products available from stock for nationwide next day delivery (same day if required!), or you can collect what you need from any of our trade counters around the UK.

Select your specialist interest below to learn more about how we can help.



Online, In Branch and On the Road - Scattergood & Johnson Ltd, there when you need us.

www.scatts.co.uk