

FL COMSERVER ... 232/422/485



Serial RS-232/422/485 device server for industrial 10/100Base-T(X) networks



Data sheet
103827_en_10

© PHOENIX CONTACT 2019-07-03

1 Description

The **FL COMSERVER...** enables the integration of serial RS-232, RS-422, and RS-485 interfaces for machine and system access via Ethernet networks. This means that you can remotely maintain all controllers and control panels via the device server.

Features

- Can be mounted on EN DIN rails
- 10/100Base-T(X) auto negotiation
- 24 V AC/DC $\pm 20\%$ power supply
- Redundant power supply possible with FL COMSERVER UNI 232/422/485 and FL COMSERVER BASIC 232/422/485
- High-quality 3-way isolation
- Comprehensive diagnostic indicators
- Configuration with web-based management (WBM)
- Password-protected configuration
- COM port redirector software

Product designation	Order No.	Temperature range	Data protocols	
			TCP/UDP	Modbus gateway/ PPP
FL COMSERVER UNI 232/422/485	2313452	-25°C ... 60°C	✓	✓
FL COMSERVER BASIC 232/422/485	2313478		✓	
FL COMSERVER UNI 232/422/485-T	2904817	-40°C ... 70°C, free-standing (40 mm separation on all sides)	✓	✓
FL COMSERVER BAS 232/422/485-T	2904681		✓	



NOTE: Device damage

The device is designed exclusively for operation with safety extra-low voltage (SELV) according to IEC 60950/EN 60950/VDE 0805. Only connect the device to devices that satisfy the requirements of EN 60950 (Safety of information technology equipment).



This data sheet is only valid in association with the corresponding packing slip and user manual. Make sure you always use the latest documentation.
It can be downloaded at phoenixcontact.net/products.

2 Table of contents

1	Description.....	1
2	Table of contents	2
3	Ordering data.....	3
4	Technical data	4
4.1	Block diagram	7
5	Safety regulations and installation notes.....	8
5.1	Installation notes	8
5.2	Installation in zone 2	8
5.3	UL notes (FL COMSERVER UNI 232/422/485 and FL COMSERVER BASIC 232/422/485 only)	9
5.4	Security in the network	10
6	Connection and function elements.....	11
6.1	Termination network.....	11
7	Serial pin assignments.....	12
8	Application examples.....	13
8.1	Point-to-point, permanent line replacement.....	13
8.2	Modbus gateway, multi-drop networks.....	13
8.3	Access to remote networks	13
8.4	Client/server mode	13
8.5	Redirector, virtual COM ports	14

3 Ordering data

FL COMSERVER...	Type	Order No.	Pcs./Pkt.
Serial device server for converting a serial RS-232/422/485 interface to Ethernet including COM port redirector software			
TCP, UDP, Modbus gateway and PPP applications	FL COMSERVER UNI 232/422/485	2313452	1
TCP and UDP applications only	FL COMSERVER BAS 232/422/485	2313478	1
FL COMSERVER...-T	Type	Order No.	Pcs./Pkt.
Variant with temperature range of -40°C ... 70°C			
TCP, UDP, Modbus gateway and PPP applications	FL COMSERVER UNI 232/422/485-T	2904817	1
TCP and UDP applications only	FL COMSERVER BAS 232/422/485-T	2904681	1
Power supply	Type	Order No.	Pcs./Pkt.
Primary-switched MINI POWER power supply for DIN rail mounting, input: 1-phase, output: 24 V DC/1.5 A	MINI-SYS-PS-100-240AC/24DC/1.5	2866983	1
Cables and D-SUB plugs	Type	Order No.	Pcs./Pkt.
RS-232 cable, 9-pos. D-SUB socket to 9-pos. D-SUB socket, 9-wire, 1:1	PSM-KA9SUB9/BB/2METER	2799474	1
D-SUB connector, 9-pos. socket, one cable entry 35°, universal type for all systems, pin assignment: 1, 2, 3, 4, 5, 6, 7, 8, 9 to screw connection terminal block	SUBCON 9/F-SH	2761499	1
D-SUB 9 data cable to USB, with adapter D-SUB 9 to D-SUB 25	CM-KBL-RS232/USB	2881078	1
Patch cable, CAT5, pre-assembled, 0.5 m	FL CAT5 PATCH 0,5	2832263	10
DIN rail connector	Type	Order No.	Pcs./Pkt.
DIN rail connector for DIN rail mounting, gold-plated contacts, 5-pos.			
17.5 mm	ME 17,5 TBUS 1,5/ 5-ST-3,81 GN	2709561	10
22.5 mm	ME 22,5 TBUS 1,5/ 5-ST-3,81 GN	2707437	50
Additional accessories	Type	Order No.	Pcs./Pkt.
Shield connection clamp for PCB terminal block	ME-SAS	2853899	10
Ethernet switch for wide temperature range, 5 TP RJ45 connections, automatic detection of data transmission speed of 10/100 Mbps (RJ45), autocrossing function, reads QoS priority messages, accepts security frames	FL SWITCH SFNT 5TX	2891003	1

4 Technical data

Power supply	FL COMSERVER...	FL COMSERVER...-T
Supply voltage range		
Via plug-in COMBICON screw terminal block	19.2 V AC/DC ... 28.8 V AC/DC	12 V AC/DC ... 30 V AC/DC (Observe derating)
Alternative or redundant, via backplane bus contact and system power supply	22.8 V DC ... 25.2 V DC	-
Nominal supply voltage		
Via COMBICON plug-in screw terminal block, frequency 50 Hz ... 60 Hz	24 V AC/DC $\pm 20\%$	24 V AC/DC $\pm 20\%$
Alternative or redundant, via backplane bus contact and system power supply	24 V DC $\pm 5\%$	-
Typical current consumption	100 mA (24 V DC)	
Electrical isolation	VCC // Ethernet // Serial (DIN EN 50178)	
Test voltage	1.5 kV _{eff} (50 Hz, 1 min)	
Serial interfaces		
Interfaces		
RS-232	ITU-T V.28, EIA/TIA-232, DIN 66259-1	
RS-422	ITU-T V.11, EIA/TIA-422, DIN 66348-1	
RS-485	EIA/TIA-485, DIN 66259-4/RS-485-2-wire	
Connection method		
RS-232	D-SUB 9 plug	
RS-422, RS-485	Plug-in/screw connection via COMBICON	
Terminator	390 Ω - 180 Ω - 390 Ω	
Pin assignment	DTE/DCE switchover via web-based management	
Data format/coding	Serial asynchronous UART/NRZ, 7/8 data, 1/2 stop, 1 parity, 10/11-bit character length	
Data flow control/protocols		
RS-232	Software handshake, Xon/Xoff, hardware handshake RTS/CTS // 3964R-compatible, Modbus RTU/ASCII	
RS-422, RS-485	Automatic	
Serial transmission speed		
RS-232	0.3; 0.6; 1.2; 2.4; 4.8; 7.2; 9.6; 19.2; 38.4; 57.6; 115.2; 187.5; 230.4 kbps	
RS-422, RS-485	0.3; 0.6; 1.2; 2.4; 4.8; 7.2; 9.6; 19.2; 38.4; 57.6; 115.2; 187.5; 230.4; 500; 1000 kbps	
Ethernet interface		
Interface	FL COMSERVER UNI...	FL COMSERVER BASIC...
	Ethernet interface, 10/100Base-T(X) according to IEEE 802.3u	
Connection method	RJ45 socket, shielded	
Serial transmission speed	10/100 Mbps, auto-negotiation	
Transmission length	≤ 100 m (twisted pair, shielded)	
Supported protocols	TCP/IP, UDP, Modbus (TCP, RTU/ASCII), PPP	TCP/IP, UDP
Secondary protocols	ARP, DHCP, BOOTP, SNMP, RIP, RARP, HTTP, TFTP, ICMP	

General data	FL COMSERVER...	FL COMSERVER...-T
Degree of protection	IP20	
Dimensions (W/H/D)	22.5 mm x 99 mm x 116 mm	45 mm x 99 mm x 116 mm
Housing material	PA 6.6 FR, green	
Weight	130 g	145 g
Vibration resistance in accordance with EN 60068-2-6/IEC 60068-2-6	5g, 10 ... 150 Hz, 2.5 h, in XYZ direction	
Shock in accordance with EN 60068-2-27/ IEC 60068-2-27		
Operation	15g, 11 ms, half-sine shock pulse	
Storage	30g, 11 ms, half-sine shock pulse	
Free fall according to IEC 60068-2-32	1 m	
Free from substances which would hinder coating with paint or varnish	VW-AUDI-Seat central standard P-VW 3.10.7 57 65 0	
MTTF (mean time to failure), SN 29500 standard		
Temperature 25°C, operating cycle 21%, 5 days a week, 8 hours a day	2001 years	1973 years
Temperature 40°C, operating cycle 34.25%, 5 days a week, 12 hours a day	870 years	854 years
Temperature 40°C, operating cycle 100%, 7 days a week, 24 hours a day	355 years	348 years
Ambient conditions	FL COMSERVER...	FL COMSERVER...-T
Ambient temperature		
Operation	-25°C ... 60°C	-40°C ... 70°C, free-standing (40 mm separation on all sides)
	-20°C ... 60°C (in accordance with UL approval)	-40°C ... 60°C (aligned without spacing)
Storage/transport	-25°C ... 70°C	-40°C ... 70°C
Humidity		
Operation	10% ... 95%	
Storage/transport	5% ... 95%	
Approvals	FL COMSERVER...	FL COMSERVER...-T
Conformance	CE-compliant	
ATEX	⊕ II 3G Ex nA IIC T4 Gc X	
Please follow the special installation instructions in section 5 on page 8!		
Standards/regulations	EN 50121-4	
Corrosive gas test	ISA-S71.04-1985 G3 Harsh Group A	
UL, USA/Canada	508 listed	No
	Class I, Div. 2, Groups A, B, C, D	
UL, USA	Class I, Zone 2, AEx nA IIC T5	No
UL, Canada	Class I, zone 2, Ex nA IIC T5 Gc X	No

Conformance with EMC directive 2014/30/EU**Noise immunity according to EN 61000-6-2**

Electrostatic discharge	EN 61000-4-2	
	Contact discharge	±6 kV
	Air discharge	±8 kV
	Comment	Criterion B
Electromagnetic HF field	EN 61000-4-3	
	Amplitude modulation	10 V/m
	Pulse modulation	10 V/m
	Comment	Criterion A
Fast transients (burst)	EN 61000-4-4	
	Signal	2 kV/5 kHz
	Comment	Criterion B
	Signal	1 kV/5 kHz
	Supply	2 kV/5 kHz
	Comment	Criterion A
Surge current loads (surge)	EN 61000-4-5	
	Signal	1 kV
	Supply	2 kV
	Comment	Criterion B
Conducted interference	EN 61000-4-6	
	Voltage	10 V
	Comment	Criterion A

Criterion A Normal operating behavior within the specified limits

Criterion B Temporary impairment of operating behavior that is corrected by the device itself.

Noise emission according to EN 61000-6-4

Noise emission of housing EN 55032, limiting curve B

4.1 Block diagram

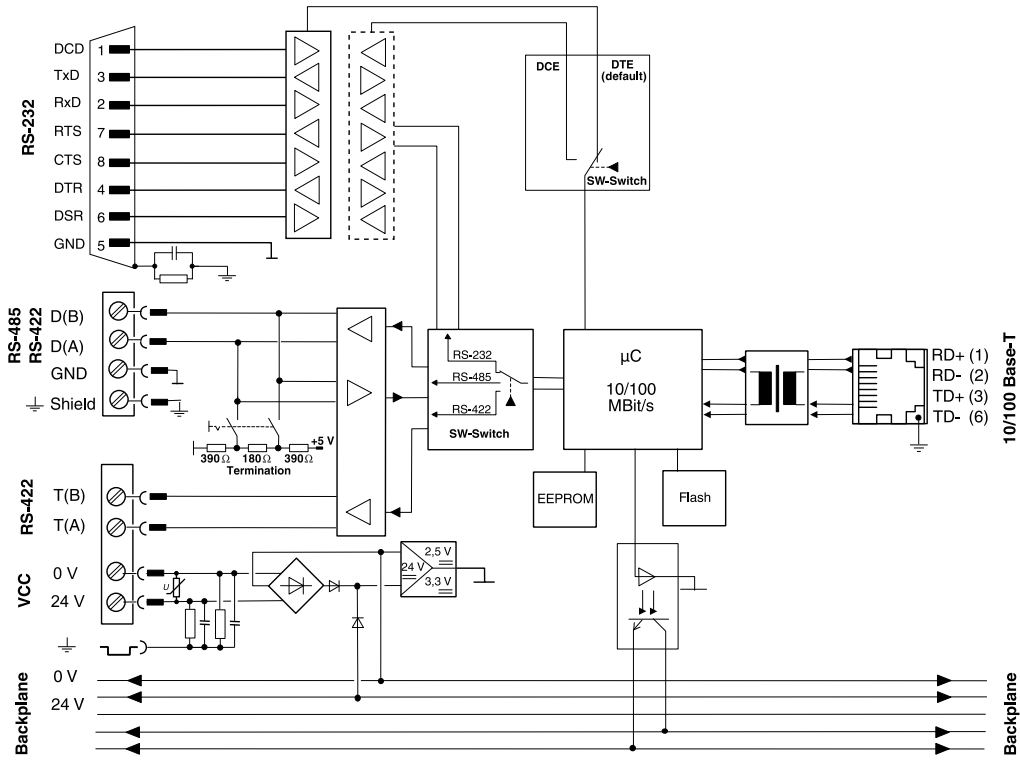

Figure 1 Block diagram

5 Safety regulations and installation notes

5.1 Installation notes



WARNING:

Observe the following safety notes when using the device!

- The category 3 device is designed for installation in zone 2 potentially explosive areas. It meets the requirements of EN 60079-0:2012+A11:2013 and EN 60079-15:2010.
- Installation, operation, and maintenance may only be carried out by qualified electricians. Follow the installation instructions as described. When installing and operating the device, the applicable regulations and safety directives (including national safety directives), as well as the generally recognized codes of practice must be observed. The safety-related data is provided in the packing slip and on the certificates (conformity assessment, additional approvals where applicable).
- The device must not be opened or modified apart from the configuration of the DIP switches. Do not repair the device yourself, but replace it with an equivalent device. Repairs may only be carried out by the manufacturer. The manufacturer is not liable for damage resulting from non-compliance.
- The IP20 degree of protection (IEC 60529/EN 60529) of the device is intended for use in a clean and dry environment. Do not subject the device to mechanical and/or thermal stress that exceeds the specified limits.
- The device is not designed for use in atmospheres with a danger of dust explosions.
- If dust is present, the device must be installed in suitable approved housing and the surface temperature of the housing must be taken into consideration.
- The switches of the device that can be accessed may only be actuated when the power supply to the device is disconnected.
- The device is designed exclusively for operation with safety extra-low voltage (SELV) in accordance with IEC 60950/EN 60950/VDE 0805. The device may only be connected to devices that meet the requirements of EN 60950.

5.2 Installation in zone 2



WARNING: Explosion hazard when used in potentially explosive areas

Make sure that the following notes and instructions are observed!

**FL COMSERVER UNI 232/422/485 and
FL COMSERVER BASIC 232/422/485**

- Observe the specified conditions for use in potentially explosive areas!
- Install the device in a suitable, approved housing (with at least IP54 protection) that meets the requirements of EN 60079-15. For this purpose, observe the requirements of IEC 60079-14/EN 60079-14.
- Only connect devices to the supply and signal circuits in zone 2 that are suitable for operation in Ex zone 2 and for the conditions at the installation location.
- In potentially explosive areas, the device may only be snapped onto or off of the DIN rail connector and cables may only be connected or disconnected when the power is disconnected.
- The device must be stopped and immediately removed from the Ex area if it is damaged, was subjected to an impermissible load, stored incorrectly or if it malfunctions.
- To ensure safe operation, the RJ connection must have a fully functioning locking clip. Repair any damaged connectors immediately.
- Connection to the D-SUB interface is only permitted if the screw connection is tightened.

**FL COMSERVER UNI 232/422/485-T and
FL COMSERVER BAS 232/422/485-T**

- Observe the specified conditions for use in potentially explosive areas!
- The device should be installed so that a degree of protection of at least IP54 is achieved in accordance with EN 60529. To this end, a suitable, approved housing that meets the requirements of EN 60079-15 should be used.
- Only devices which are designed for operation in Ex zone 2 and are suitable for the conditions at the installation location may be connected to the circuits in zone 2.
- In potentially explosive areas, connect and disconnect cables only when the power is disconnected.
- The switches of the device that can be accessed may only be actuated when the power supply to the device is disconnected.
- The device must be stopped and immediately removed from the Ex area if it is damaged, was subjected to an impermissible load, stored incorrectly or if it malfunctions.
- To ensure safe operation, the RJ45 connector must have a fully functioning locking clip. Damaged connectors must be repaired immediately.
- Connection to the D-SUB interface is only permitted if the screw connection is fully tightened.

**5.3 UL notes
(FL COMSERVER UNI 232/422/485 and
FL COMSERVER BASIC 232/422/485 only)**



**WARNING: Explosion hazard when used in
potentially explosive areas**

Make sure that the following notes and instructions are observed!

**PROCESS CONTROL EQUIPMENT FOR HAZARDOUS
LOCATIONS 31ZN**

- A This equipment is suitable for use in Class I, Zone 2, AEx nA IIC T5; Class I, Zone 2, Ex nA IIC T5 Gc X and Class I, Division 2, Groups A, B, C, D or non-hazardous locations only.
- B Conductor temperature rating must be 65°C or higher.
- C Product must be installed in Class I, Zone 2 certified and at least an IP54 enclosure.
- D Product must be used in no more than a degree of pollution 2 environment as defined by IEC 60664-1.
- E Provisions must be made to provide transient protection to the product so that voltage levels do not exceed 40 % of the rated voltage at the power supply terminals.
- F The product has to be installed in an enclosure with tool removable cover or door.

Ambient temperature: -20°C ... +60°C

24 V AC/DC <120 mA

Wire Range: 30-12 AWG

Torque: 5-7 (Lbs-In)

5.4 Security in the network

**NOTE: Risk of unauthorized network access**

Connecting devices to a network via Ethernet entails the danger of unauthorized access to the network.

Observe the following safety notes!

- If possible, deactivate unused communication channels.
- Assign passwords such that third-parties cannot access the device and make unauthorized changes.
- Due to its communication interfaces, the device should not be used in safety-critical applications unless additional security appliances are used. Please take additional protective measures in accordance with the IT security requirements and the standards applicable to your application (e.g., virtual networks (VPN) for remote maintenance access, firewalls, etc.) for protection against unauthorized network access.
- On first request, you shall release Phoenix Contact and the companies associated with Phoenix Contact GmbH & Co. KG, Flachsmarktstrasse 8, 32825 Blomberg in accordance with §§15ff.AktG (German Stock Corporation Act), hereinafter collectively referred to as "Phoenix Contact", from all third-party claims made due to improper use.
- For the protection of networks for remote maintenance via VPN, Phoenix Contact offers the mGuard product series security appliances; further information on this is available in the latest Phoenix Contact catalog (phoenixcontact.net/products).
- Additional measures for protection against unauthorized network access can be found in the AH EN INDUSTRIAL SECURITY application note. The application note can be downloaded via the product at phoenixcontact.net/product/2313452.

6 Connection and function elements

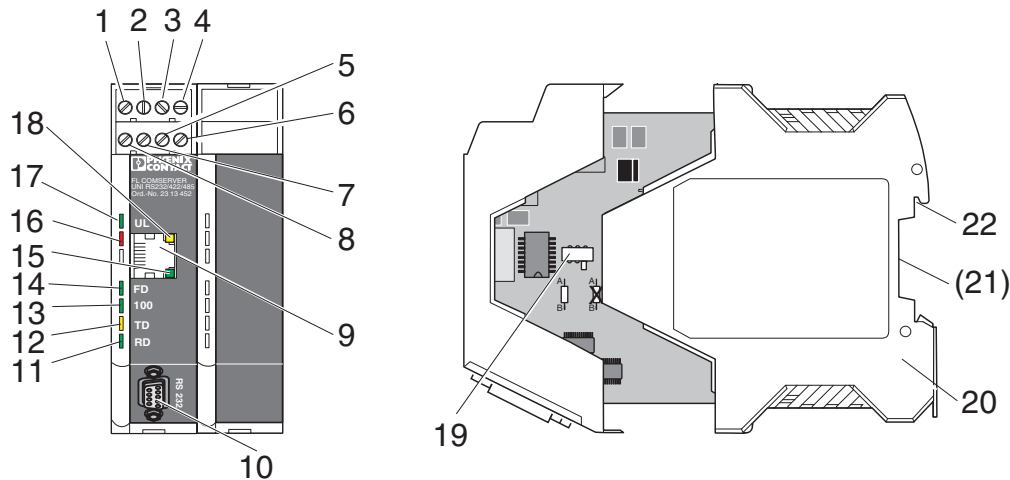

Figure 2 Connection and function elements

1	24 V supply
2	0 V supply
3	T(A) RS-422 connection, transmit, negative
4	T(B) RS-422 connection, transmit, positive
5	D(A) RS-422/485 connection, receive, negative
6	D(B) RS-422/485 connection, receive, positive
7	GND
8	Shield, same potential as FE
9	RJ45, Ethernet interface (TP port)
10	D-SUB 9: RS-232 interface, pin strip
11	Green LED, RD, reception of serial data
12	Yellow LED, TD, transmission of serial data
13	Green LED, 100, 100 Mbps transmission speed
14	Green LED, FD, full duplex mode active
15	Green LED, Link status TP port
16	Red LED, error display
17	Green LED, UL, power supply
18	Yellow LED, ACT, data transmission TP port, dynamic
19	Slide switch for RS-422/485 termination network
20	Snap-on foot for DIN rail mounting
(21)	FL COMSERVER UNI 232/422/485 and FL COMSERVER BASIC 232/422/485 only: Bus connector for redundant supply voltage (concealed)
22	FE, functional earth ground contact (concealed)

6.1 Termination network

The FL COMSERVER... can be operated on a 2-wire or 4-wire bus cable as required. For correct operation of the bus system, termination networks are required for the RS-422/485 bus connection.

The FL COMSERVER... is equipped with a switchable termination network upon delivery.

RS-422

In the case of a point-to-point connection, you must activate the termination network on both devices.

RS-485

In the case of multipoint connections, you must activate the termination network on the first and last bus device of the line.

7 Serial pin assignments



Observe the different interface configuration when changing a device from FL COM SERVER RS... to FL COMSERVER ... 232/422/485. When connecting the device, make sure the signal assignment of the interfaces is correct.



You have to disconnect the 9-pos. D-SUB connector from the data cable when changing a device from the FL COM SERVER RS... to the FL COMSERVER ... 232/422/485. Connect the single wires of the data cable to the COMBICON plug-in screw terminal block. Make sure the signal assignment is correct.

RS-232 pin assignment



The RS-232 interface can be switched via WBM between DTE (data terminal equipment) and DCE (data communication equipment) assignment. By default upon delivery (DTE), the interface behaves like a PC.

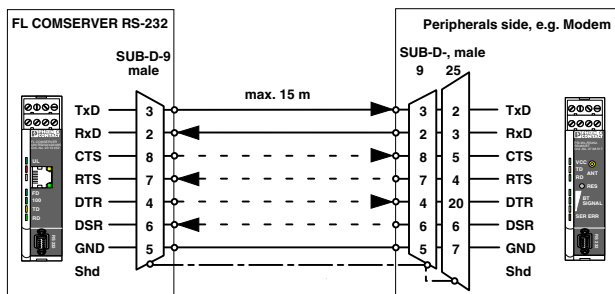

Figure 3 RS-232 pin assignment

RS-422 pin assignment

In RS-422 mode, a point-to-point connection can be established. When connecting the I/O device, use a common shielded twisted pair bus line. Fit this bus cable with a termination network on both I/O devices.

This operational mode supports full duplex transmission mode.

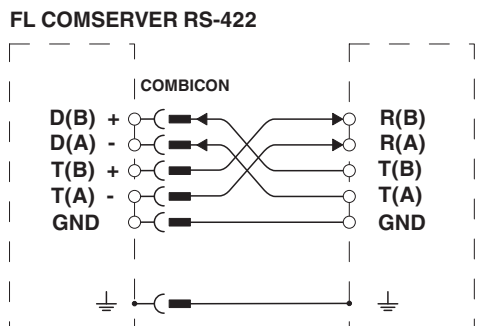

Figure 4 RS-422 pin assignment

RS-485 pin assignment

In RS-485 mode, a network with several I/O devices can be created. When connecting the I/O devices, use a common shielded twisted pair bus line. Install this bus cable with a termination network at the two furthest points.

FL COMSERVER RS-485

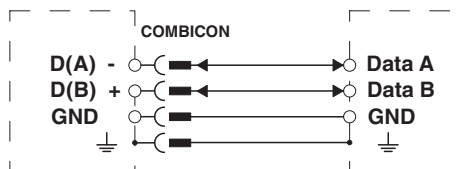

Figure 5 RS-485 pin assignment

8 Application examples

8.1 Point-to-point, permanent line replacement

A common application is the point-to-point connection of two serial devices via an existing network. For this cable replacement, the data is tunneled through the network using two FL COMSERVER... Any limits on range (e.g., the maximum of 15 m imposed by RS-232) are thus overridden.

You can easily replace permanent lines phased out by telecommunications companies using DSL technology.

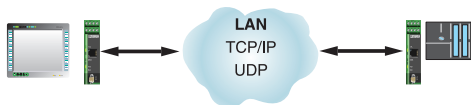

Figure 6 Point-to-point connection

8.2 Modbus gateway, multi-drop networks

You can even extend or replace conventional RS-485 multi-drop networks with modern network technology using the FL COMSERVER...

Modbus is the best-known version of this technology. The FL COMSERVER... supports the serial Modbus/ASCII and RTU protocols as well as the Ethernet-based Modbus/TCP protocol. The full-fledged gateway function enables use with Modbus masters and slaves, and therefore the integration of any number of serial Modbus devices into Modbus/TCP networks.

You can directly address other multidrop networks using simple broadcast addressing sent out to all network devices or using intelligent mechanisms. The required destination address is read directly from the serial data stream and used for addressing.

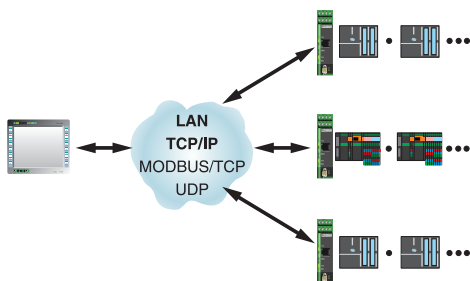

Figure 7 Modbus gateway

8.3 Access to remote networks

Dialing into remote networks that are otherwise difficult to access (e.g., wind farms) can now be easily ensured via a modem connection (dial-up) in combination with the FL COMSERVER... The FL COMSERVER... supports the PPP protocol with CHAP authentication (Challenge Handshake Authentication Protocol). 128-bit password encryption protects the network from unauthorized access.

You can combine the FL COMSERVER... with a Bluetooth converter to create a Bluetooth access point. This enables the wireless integration of serial devices in an Ethernet network with a range of up to 150 m.

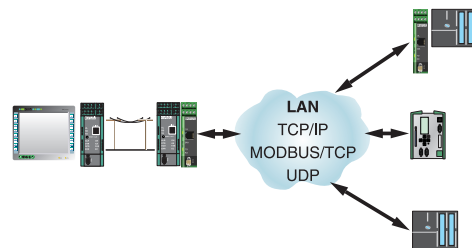

Figure 8 Access to remote networks

8.4 Client/server mode

If, however, the serial data of an application software program is to be available in the network, only one FL COMSERVER... is installed at the serial device. In its function as a client or server, the FL COMSERVER... can then make the data available and transmit it in TCP/IP or UDP. The sockets of the application software can therefore directly access the serial data in the field.

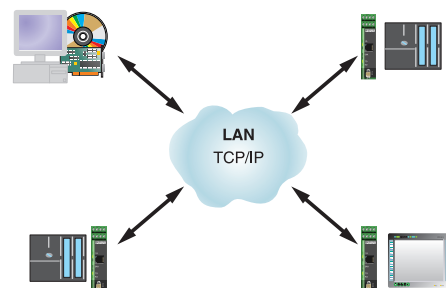

Figure 9 Client/server mode

8.5 Redirector, virtual COM ports

In many cases, the existing application software does not support Ethernet communication. However, in the face of increasing networking, local connections, e.g., to programming interfaces, should often be established via the PC's existing network card and the connected network. The COM port redirector, which is supplied as standard, provides the solution here. It creates virtual COM ports on the PC that can be used by the existing application software. You do not need to change the application software. This means you can easily establish connections to programming interfaces while retaining all the advantages of networking.

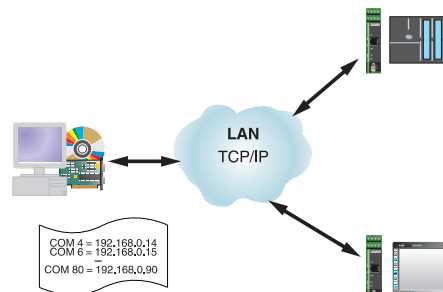
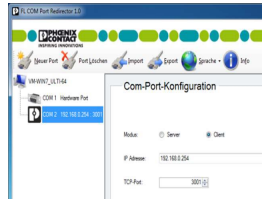
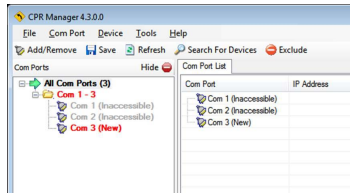

Figure 10 Redirector

Redirector software	Number of virtual ports	Operating system
<p>FL COM port redirector</p> 	<p>≤16 (as of version 1.50)</p>	<p>Windows® XP and later (32/64 bit)</p>
<p>CPR Manager (as of firmware version E2.20)</p> 	<p>≤254</p>	<p>Windows® XP, 2003 Server, Vista, 7, 2008 Server (32/64 bit)</p>



SCATTERGOOD & JOHNSON LTD

ELECTRICAL ENGINEERING & FLUID CONTROL DISTRIBUTORS

Est.1899

At Scattergood & Johnson Ltd, we pride ourselves on being a technical distributor to specialist industries.

Working with a range of quality product suppliers across a number of specialist markets, we are not your average 'box shifter' - we are your technical and supply chain partner.

We fully support every product we sell - for free! Our internal team and external sales engineers can answer any product or application question, no matter the complexity.

Backing up this technical ability is a range of 50,000+ products available from stock for nationwide next day delivery (same day if required!), or you can collect what you need from any of our trade counters around the UK.

Select your specialist interest below to learn more about how we can help.



Online, In Branch and On the Road - Scattergood & Johnson Ltd, there when you need us.

www.scatts.co.uk