

RAD-RS485-IFS



TRUSTED
WIRELESS™



RS-485 front module for Radioline I/O extension modules

Data sheet
106318_en_03

© PHOENIX CONTACT 2019-07-01

1 Description

The RS-485 front module for I/O extension modules allows Radioline stations to be operated via a 2-wire RS-485 bus system. The front module can be extended with up to 32 I/O extension modules via the DIN rail connector.

Addressing of the front module and I/O mapping of the extension modules is carried out quickly and easily using the thumbwheel on the front. You can therefore distribute I/O signals in an RS-485 bus system easily, without any programming or configuration.

Alternatively, you can operate the stations via the Modbus/RTU protocol and integrate them in any Modbus network.

The front modules can also be connected to a Radioline wireless master, thereby offering cross-media I/O mapping between the wireless network and RS-485 bus system.

Features

- Multipoint multiplexer - easy I/O distribution between multiple stations
- Up to 99 stations per network
- Addressing using the thumbwheel on the front, quick and easy startup
- Can be extended with up to 32 I/O modules per station via DIN rail connector (hot-swappable)
- I/O-to-serial operation as Modbus/RTU bus coupler at a Modbus master
- Can be combined with Radioline wireless modules
- Installation in Ex zone 2



WARNING: Explosion hazard when used in potentially explosive areas

The device is a category 3 item of electrical equipment. Follow the instructions provided here during installation and observe the safety notes.



Make sure you always use the latest documentation.

It can be downloaded at: [phoenixcontact.net/product/2702184](https://www.phoenixcontact.net/product/2702184)

2	Table of contents	
1	Description	1
2	Table of contents	2
3	Ordering data	3
4	Technical data	5
5	Safety regulations and installation notes.....	7
	5.1 Intended use	7
	5.2 Installation notes	7
	5.3 Installation in Zone 2.....	8
	5.4 UL notes.....	8
6	Installation	9
	6.1 Unpacking	9
	6.2 Basic circuit diagram	9
	6.3 Product description	9
	6.4 Display and diagnostic elements	10
	6.5 Mounting and removing.....	11
	6.6 Connecting cables	12
7	Startup and configuration.....	13
	7.1 Resetting to the default settings.....	13
	7.2 Setting the station address (RAD-ID)	13
	7.3 Set the interface parameters with the thumbwheel	13
	7.4 I/O data transmission	14
	7.5 PSI-CONF configuration and diagnostics software	14
	7.6 Behavior of the input and output modules in the event of interrupted bus connection	14
	7.7 Copying device settings to new network devices	15
8	Application examples	16
	8.1 Multipoint multiplexer via RS-485 (I/O-to-I/O)	16
	8.2 Connection to Radioline wireless systems (I/O-to-I/O).....	16
	8.3 Modbus/RTU slave (I/O-to-serial)	17
	8.4 Wireless system and RS-485 stations at a Modbus master (I/O-to-serial).....	17
9	Process data.....	18
10	Alternative transmission media for increasing the range.....	19
	10.1 RS-485 repeaters	19
	10.2 Fiber optic converters	19
	10.3 SHDSL extender	20
	10.4 Serial device server.....	20
	10.5 Transparent wireless path.....	20
11	Disposal.....	20

3 Ordering data

Description	Type	Order No.	Pcs./Pkt.
Radioline - RS-485 multipoint multiplexer, can be extended with I/O modules, can be used as Modbus/RTU bus coupler or can be combined with Radioline wireless system, up to 99 stations, range of up to 1.2 km on in-house copper cables	RAD-RS485-IFS	2702184	1
Accessories	Type	Order No.	Pcs./Pkt.
Radioline - I/O extension module, 2 digital inputs and outputs (0 ... 250 V AC/DC) and 1 analog input (0/4 ... 20 mA) and output (0/4 ... 20 mA, 0 ... 10 V)	RAD-DAIO6-IFS	2901533	1
Radioline - I/O extension module, 4 digital inputs (0 ... 250 V AC/DC)	RAD-DI4-IFS	2901535	1
Radioline - I/O extension module, 4 digital relay outputs (5 A, 250 V AC/DC)	RAD-DOR4-IFS	2901536	1
Radioline - I/O extension module, 8 digital inputs (0 ... 30.5 V DC) or 2 pulse inputs up to 100 Hz	RAD-DI8-IFS	2901539	1
Radioline - I/O extension module, 8 digital transistor outputs (30.5 V DC/200 mA)	RAD-DO8-IFS	2902811	1
Radioline - I/O extension module, 4 analog current inputs (0/4 mA ... 20 mA)	RAD-AI4-IFS	2901537	1
Radioline - I/O extension module, 4 analog current or voltage outputs (0/4 mA ... 20 mA, 0 V ... 10 V)	RAD-AO4-IFS	2901538	1
Radioline - I/O extension module, 4 Pt 100 inputs (-50°C ... +250°C / -58 °F ... 482 °F)	RAD-PT100-4-IFS	2904035	1
Radioline - 2.4 GHz wireless transceiver with RS-232/RS-485 interface, can be extended with I/O modules, RSMA (female) antenna connection, point-to-point, star, and mesh networks up to 250 stations, range of up to 5 km (with a clear line of sight), for worldwide use	RAD-2400-IFS	2901541	1
Radioline - 868 MHz wireless transceiver with RS-232/RS-485 interface, can be extended with I/O modules, RSMA (female) antenna connection, point-to-point, star, and mesh networks up to 99 stations, range of up to 20 km (with a clear line of sight), for use in Europe	RAD-868-IFS	2904909	1
Radioline - 900 MHz wireless transceiver with RS-232/485 interface, can be extended with I/O modules, RSMA (female) antenna connection, point-to-point, star, and mesh networks up to 250 stations, range of up to 32 km (line of sight), use in North America	RAD-900-IFS	2901540	1
Radioline - USB data cable for communication between the PC and Radioline devices, energy supply for diagnostics and configuration via the USB port of the PC, cable length: 2 m / 6.5 ft	RAD-CABLE-USB	2903447	1

Accessories	Type	Order No.	Pcs./Pkt.
Primary-switched MINI POWER supply for DIN rail mounting, input: 1-phase, output: 24 V DC/1.5 A	MINI-SYS-PS-100-240AC/24DC/1.5	2866983	1
Shield connection terminal block, for applying the shield to busbars	SKS 8-SNS35	3062786	10
Radioline - memory stick for saving custom configuration data	RAD-MEMORY	2902828	1
PCB connector, nominal current: 10 A, rated voltage (III/2): 320 V, number of positions: 3, pitch: 5 mm, connection method: Push-in spring connection, color: green, contact surface: tin	TVFKC 1,5/ 3-ST	1713842	50
Surge protection, consisting of protective plug and base element, with integrated status indicator and knife disconnection for three signal wires with common reference potential. For HF applications and telecommunications interfaces without supply voltage. Indirect grounding via gas-filled surge arrester.	TTC-6P-3-HF-F-M-12DC-PT-I	2906796	1
Radioline - I/O extension module, 4 NAMUR digital input module used in Radioline and PROFIBUS PA MUX I/O systems. Fulfills the NAMUR proximity sensor standard EN 60947-5-6, and communication to the head stations for Radioline systems and the FB-MUX/HS...PA via the T-BUS connector installed on the DIN rail. This module has channel-to-channel isolation.	RAD-NAM4-IFS	2316275	1
Radioline - I/O extension module, 4 analog voltage inputs (0 ... 5 V, 0 ... 10 V)	RAD-AI4-U-IFS	2702290	1



The extension modules RAD-AI4-U-IFS and RAD-NAM4-IFS will be supported as of firmware version 1.90.

4 Technical data

Dimensions	
Dimensions W/H/D	17.5 mm / 113 mm / 114.5 mm
General data	
Overvoltage category	II
Degree of protection	IP20
Degree of pollution	2
Type of housing	PA 6.6-FR, green
Flammability rating according to UL 94	V0
MTTF (mean time to failure) Telcordia standard, 25°C temperature, 21% operating cycle (5 days a week, 8 hours a day)	1233 Years
MTTF (mean time to failure) Telcordia standard, 40°C temperature, 34.25% operating cycle (5 days a week, 12 hours a day)	514 Years
MTTF (mean time to failure) Telcordia standard, temperature 40 °C, operating cycle 100 % (7 days a week, 24 hours a day)	212 Years
Supply	
Supply voltage range	19.2 V DC ... 30.5 V DC
Max. current consumption	≤ 65 mA (at 24 V DC, at 25 °C, stand-alone) ≤ 6 A (at 24 V DC, with DIN rail connector at full capacity)
Transient surge protection	Yes
System limits	
Number of supported devices	≤ 99 (addressing via thumbwheel)
Number of possible extension modules	≤ 32 (per module)
RS-485, 2-wire	
Connection method	COMBICON plug-in screw terminal block
Transmission speed (default setting: 19.2/8/E/1)	300 bps 600 bps 1.2 kbps 2.4 kbps 4.8 kbps 9.6 kbps 19.2 kbps 38.4 kbps 57.6 kbps 93.75 kbps 115.2 kbps
Transmission length	≤ 1200 m
Termination resistor (switchable via DIP switches)	390 Ω / 150 Ω / 390 Ω

Configuration interface	
Connection method	S-PORT (socket)
Link relay output	
Contact type	PDT
Contact material	PdRu, gold-plated
Maximum switching voltage	30 V AC/DC 60 V DC
Max. switching current	500 mA (30 V AC/DC) 300 mA (60 V DC)
Electrical service life	5x 10 ⁵ switching cycles with 0.5 A at 30 V DC
Connection data	
Connection method	Screw connection
Conductor cross section, solid	0.2 mm ² ... 2.5 mm ²
Conductor cross section, flexible	0.2 mm ² ... 2.5 mm ²
Conductor cross section AWG/kcmil	24 ... 14
Stripping length	7 mm
Tightening torque	0.6 Nm
Status indication	
Status display	Green LED (supply voltage, PWR) Green LED (bus communication, DAT) Red LED (periphery error, ERR) Green LED (receive data, RX) Green LED (transmit data, TX)
Ambient conditions	
Ambient temperature (operation)	-40 °C ... 70 °C (>55°C derating) -40 °F ... 158 °F (>131°F derating)
Ambient temperature (storage/transport)	-40 °C ... 85 °C -40 °F ... 185 °F
Permissible humidity (operation)	20 % ... 85 %
Permissible humidity (storage/transport)	20 % ... 85 %
Altitude	2000 m
Vibration (operation)	in accordance with IEC 60068-2-6: 5g, 10 Hz ... 150 Hz
Shock	16g, 11 ms
Certification	
Conformance	CE-compliant
ATEX Please follow the special installation instructions in the documentation!	⊕ II 3 G Ex nA nC IIC T4 Gc (IBExU 15 ATEX B008 X)
IECEX	Ex nA nC IIC T4 Gc (IECEX IBE 13.0019X)
UL, USA/Canada	UL 508 Listed Class I, Div. 2, Groups A, B, C, D T4A Class I, Zone 2, IIC T4
Noxious gas test	ISA-S71.04-1985 G3 Harsh Group A

5 Safety regulations and installation notes

5.1 Intended use

The devices are intended for application in industrial environments.

5.2 Installation notes



WARNING: Risk of electric shock

During operation, certain parts of this device may carry hazardous voltages. Disregarding this warning may result in damage to equipment and/or serious personal injury.

- Provide a switch/circuit breaker close to the device, which is labeled as the disconnect device for this device or the entire control cabinet.
- Provide overcurrent protection ($I \leq 6 \text{ A}$) in the installation.
- Disconnect the device from all power sources during maintenance work and configuration (the device can remain connected to SELV or PELV circuits).
- The housing of the device provides a basic insulation against the neighboring devices, for 300 V eff. If several devices are installed next to each other, this has to be taken into account, and additional insulation has to be installed if necessary. If the neighboring device is equipped with basic insulation, no additional insulation is necessary.

- The category 3 device is designed for installation in zone 2 potentially explosive areas. It meets the requirements of EN 60079-0:2012+A11:2013 and EN 60079-15:2010.
- Installation, operation, and maintenance may only be carried out by qualified electricians. Follow the installation instructions as described.
- When installing and operating the device, the applicable regulations and safety directives (including national safety directives), as well as general technical regulations, must be observed. The technical data is provided in the package slip and on the certificates (conformity assessment, additional approvals where applicable).
- The device must not be opened or modified. Do not repair the device yourself, replace it with an equivalent device. Repairs may only be carried out by the manufacturer. The manufacturer is not liable for damage resulting from violation.
- The IP20 protection (IEC 60529/EN 60529) of the device is intended for use in a clean and dry environment. The device must not be subject to mechanical strain and/or thermal loads, which exceed the limits described.
- To protect the device against mechanical or electrical damage, install it in a suitable housing with appropriate degree of protection as per IEC 60529.
- Only specified devices from Phoenix Contact may be connected to the 12-pos. S-PORT interface.
- The device is not designed for use in atmospheres with a danger of dust explosions.
- If dust is present, it is necessary to install into a suitable approved housing, whereby the surface temperature of the housing must be taken into consideration.

WARNING: Explosion hazard when used in potentially explosive areas

Please make sure that the following notes and instructions are observed.

5.3 Installation in Zone 2

- Observe the specified conditions for use in potentially explosive areas! Install the device in a suitable, approved housing that meets the requirements of IEC/EN 60079-15 and has at least IP54 protection. Also observe the requirements of IEC/EN 60079-14.
- In zone 2, only connect devices to the supply and signal circuits that are suitable for operation in the Ex zone 2 and the conditions at the installation location.
- In potentially explosive areas, terminals may only be snapped onto or off the DIN rail connector and wires may only be connected or disconnected when the power is switched off.
- The switches of the device that can be accessed may only be actuated when the power supply to the device is disconnected.
- The device must be stopped and immediately removed from the Ex area if it is damaged, was subject to an impermissible load, stored incorrectly or if it malfunctions.

5.4 UL notes
INDUSTRIAL CONTROL EQUIPMENT FOR HAZARDOUS LOCATIONS 45FP

- A THIS EQUIPMENT IS SUITABLE FOR USE IN CLASS I, DIVISION 2, GROUPS A, B, C, AND D HAZARDOUS LOCATIONS OR NON-HAZARDOUS LOCATIONS ONLY.
- B WARNING - EXPLOSION HAZARD - DO NOT DISCONNECT EQUIPMENT UNLESS POWER HAS BEEN SWITCHED OFF OR THE AREA IS KNOWN TO BE NON-HAZARDOUS.
- C WARNING - EXPLOSION HAZARD - SUBSTITUTION OF COMPONENTS MAY IMPAIR SUITABILITY FOR CLASS 1, DIVISION 2.
- D These devices are open-type devices that are to be installed in an enclosure suitable for the environment that is only accessible with the use of a tool.
- E WARNING - Exposure to some chemicals may degrade the sealing properties of materials used in relays within this device.
- F WARNING - EXPLOSION HAZARD - S-PORT IS FOR MAINTENANCE AND PROGRAMMING ONLY AND SHOULD ONLY BE USED WHEN THE AREA IS KNOWN TO BE NON-HAZARDOUS.

6 Installation



NOTE: electrostatic discharge!

Electrostatic discharge can damage or destroy components.

- When handling the device, observe the necessary safety precautions against electrostatic discharge (ESD) according to EN 61340-5-1 and IEC 61340-5-1.

6.1 Unpacking

- Check the delivery for visible damage caused by transportation.
- Submit claims for any transport damage immediately. Inform Phoenix Contact or your supplier as well as the shipping company without delay.
- Read the complete packing slip carefully.
- Retain the packing slip.
- Keep the packaging for a possible later transport.

6.2 Basic circuit diagram

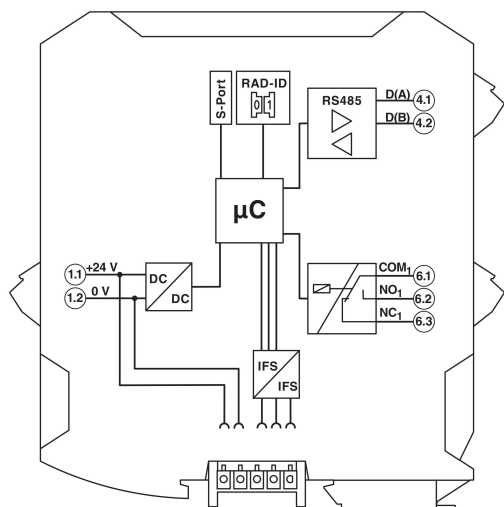

Figure 1 Basic circuit diagram

6.3 Product description

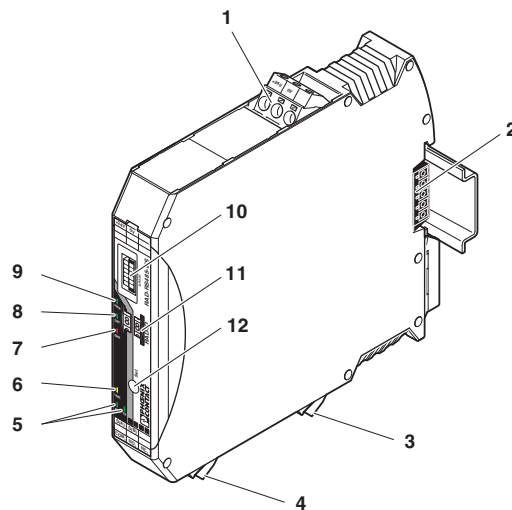

Figure 2 Function elements

Pos.	Designation		
1	+24 V/0 V	1.1 / 1.2	Device supply
2	Connection for DIN rail connector		
3	Link relay	6.1 / 6.2 / 6.3	Relay output with PDT contact (floating)
4	D(A)	4.1	negative
	D(B)	4.2	positive
RS-485 interface			
5 - 9	Diagnostic and status indicators		
10	S-PORT	12-pos. programming interface	
11	RAD-ID	Address setting via thumbwheel	
12	SET button		

6.4 Display and diagnostic elements

The front module indicates the operating states with six LEDs.

PWR-LED

The green PWR LED indicates the supply voltage status.

Off	no supply voltage
On	Supply voltage OK

DAT-LED

The green DAT LED indicates the status of local communication with the extension modules via the DIN rail connector.

Off	No communication
Flashing	Configuration mode
On	Cyclic data communication

ERR-LED

The red ERR LED indicates the error status.

Off	no error	
Flashing	Slow (1.4 Hz)	Double assignment of the I/O MAP address, missing input module, missing output module, modified RAD ID
	Fast (2.8 Hz)	Link to system master (RAD-ID 01) or Modbus master lost
On		Local bus error

LINK-LED

Flashing	Activated as soon as the master activates the slave with the station address (RAD ID).
----------	--

TX-LED

The green TX LED indicates communication (transmit data) with the RS-485 interface.

RX-LED

The green RX LED indicates communication (receive data) with the RS-485 interface.

SET button

The SET button is used to confirm a station change, without performing a power up.

Press the SET button for one second after making any change to the network or the local station. The DAT LED starts flashing and the settings are applied. Read in has been completed when the DAT LED is permanently on.

Station changes:

- RAD ID address of front module changed
- I/O MAP address of extension modules changed
- I/O extension module added
- I/O extension module removed
- Memory stick used

Link relay output

The link relay switches on when the link LED is active.

The link relay is deactivated when the link LED goes out.

6.5 Mounting and removing

Connection station with I/O extension modules

Up to 32 different I/O extension modules can be connected to every front module via the DIN rail connector (see accessories). Data is transmitted and power is supplied to the I/O extension modules via the bus foot.

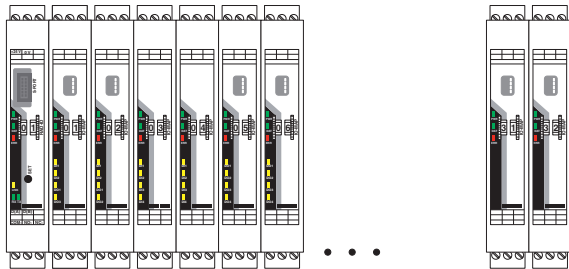

Figure 3 Radioline connection station with up to 32 I/O extension modules



Only mount the I/O extension modules to the right of the front module.

You can connect a maximum of 32 I/O extension modules to a station.

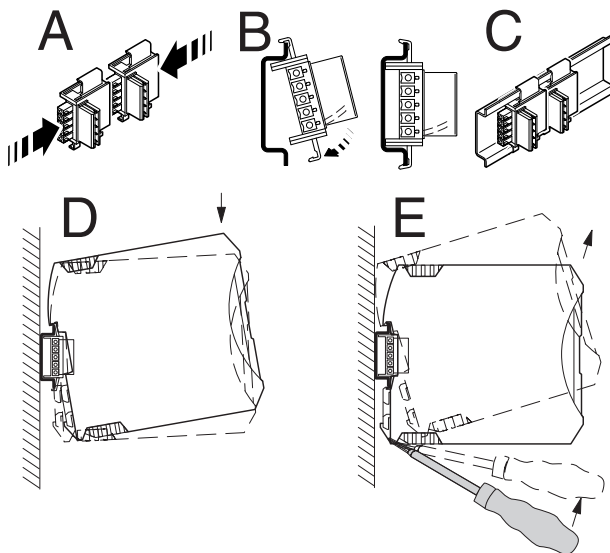

Figure 4 Mounting and removing

Mounting

When using the device in a connection station, use the 17.5 mm wide DIN rail connector supplied. Only use the DIN rail connector in connection with 24 V DC devices.



Outside the Ex area, module extension or module replacement is also possible during operation.

- Connect the DIN rail connectors together for a connection station.
- Push the connected DIN rail connectors into the DIN rail.
- Place the device onto the DIN rail from above. Ensure the device and DIN rail connector are aligned correctly.
- Holding the device by the housing cover, carefully push the device towards the mounting surface so that the device bus connector is securely fixed onto the DIN rail connector.
- Once the snap-on foot has been audibly snapped onto the DIN rail, check that it is fixed securely. The device is only mechanically secured via the DIN rail.
- Connect the desired number of I/O extension modules to the front module via the DIN rail connector
- In order to meet the requirements for the protection class, install the device in suitable housing.
- During startup, check that the device is operating, wired, and marked correctly.
- You can establish a connection between two DIN rail connectors using MINI COMBICON connectors: MC 1,5/5-ST-3,81 (female, 1803604); IMC 1,5/5-ST-3,81 (male, 1857919).

Removing

- Use a suitable screwdriver to release the locking mechanism on the snap-on foot of the device.
- Hold onto the device by the housing cover and carefully tilt it upwards.
- Carefully lift the device off the DIN rail connector and the DIN rail.

6.6 Connecting cables

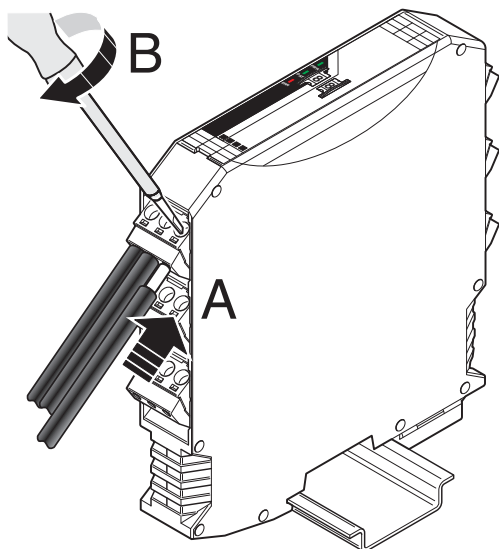

Figure 5 Connecting cables

- Only connect the front module to devices that satisfy the requirements of EN 60950 (Safety of information technology equipment).
- Crimp ferrules to the wires.
Permissible cable cross section: 0.2...2.5 mm².
- Insert the wire with ferrule into the corresponding connection terminal block.
- Use a screwdriver to tighten the screw in the opening above the connection terminal block.
Tightening torque: 0.6 Nm

Shielding

- Connect the shield of the RS-485 bus line correctly via an external shield connection clamp (e.g. SKS 8-SNS35, Order No. 3062786).



NOTE: damage to the interface
A faulty connection of the shield in combination with permanent external interferences can cause damage to the RS-485 interface.
Observe the polarity of the RS-485 2-wire cable and ensure that the shield connection is connected correctly.

Choose the type of shield connection according to the type of interference expected:

- Firstly, connect the shield on one side. This suppresses electrical fields.
- To suppress disturbances caused by alternating magnetic fields, connect the shield on both sides. When doing so, the ground loops must be taken into account: galvanic disturbances along the reference potential can interfere with the useful signal, and the shielding effect is reduced.
- If several devices are connected to a single bus, the shield must be connected to each device (e.g., by means of clamps).
- Connect the bus shield to a central PE point using short, low-impedance connections with a large surface area (e.g., by means of shield connection clamps).

Termination network

The front module is operated on a 2-wire bus line. For correct operation of the bus system, termination networks are required for the RS-485 bus connection

- Terminate an RS-485 bus line at both bus ends. To do so, verify the position of the front module on the RS-485 bus line and set the required operating mode via the DIP switch.

		DIP	
Operating mode	Termination network	1	2
RS-485 termination device	On	ON	ON
RS-485 device	Off	OFF	OFF

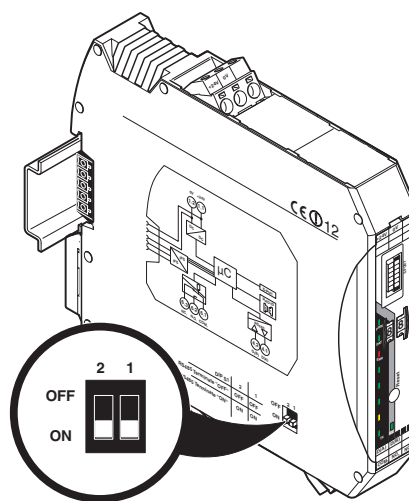

Figure 6 DIP switches

RS-485 pin assignment

Use a twisted pair bus line to connect the I/O devices. Activate the termination networks at the two furthest points of the RS-485 network.

- Connect the individual conductors of the data cable to the COMBICON plug-in screw terminal block (Figure 1, item 4).
- Make sure the signal assignment is correct.

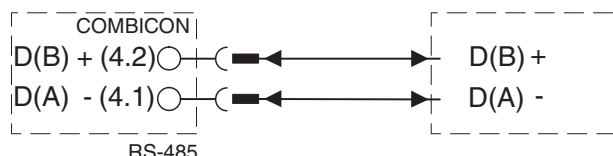

Figure 7 Pin assignment

7 Startup and configuration

Addressing of the front module and I/O mapping of the extension modules is carried out quickly and easily using the thumbwheel on the front. You can therefore distribute I/O signals in an RS-485 bus system easily, without any programming or configuration.

A master (RAD ID = 01) and up to 98 slave stations (RAD ID = 02 ... 99) are always required for operation. Only **one** master may be operated in a network. The master is detected automatically.

Possible masters:

- Radioline wireless module
- Radioline RS-485 front module
- Any Modbus/RTU master

Default setting of the RS-485 interface: 19.2/8/E/1

All devices are configured in the same way by default.

7.1 Resetting to the default settings

- Disconnect the device from the supply voltage.
- Hold down the SET button located on the front of the device.
- Switch the supply voltage back on.
- Press and hold the SET button until the DAT LED flashes.

Alternatively, you can reset the device to the default settings using the PSI-CONF software.

7.2 Setting the station address (RAD-ID)

- Address the device in the network using the thumbwheel.

Start by setting the desired station address with the yellow thumbwheel on the front module. There must be one master and at least one slave in a network.

If you set two front modules to the same address, the network will not function correctly.

Thumbwheel (RAD-ID)	Description
01	Master
02 - 99	Slave
00	Not permitted

- Press and hold down the SET button on the front module for one second.



Each address in a network must be unique.

7.3 Set the interface parameters with the thumbwheel

If you are operating the front module on an arbitrary Modbus master, you can also set the parameters of the RS-485 interface without software only with the thumbwheel.

The thumbwheel can also be adjusted during operation.

- Set the desired interface parameters with the thumbwheel (see following table).
- Press the SET button for less than one second.

The setting is applied immediately. The DAT LED flashes as confirmation.

- After configuration: Set the valid RAD ID address on the thumbwheel again.



During configuration, the red ERR LED flashes slowly at 1.4 Hz until you have set the valid RAD ID address again.

Thumbwheel (only configuration)	Parameters of the RS-485 interface
5*	9600/8/E/1
6*	19200/8/E/1
7*	38400/8/E/1
8*	56700/8/E/1
9*	115200/8/E/1

7.4 I/O data transmission

In order to enable the transmission of signals, you must assign a corresponding output module to the input module.

Use the white thumbwheel on the I/O extension module to set the I/O MAP address (01 ... 99). The input device must be provided with the same I/O MAP address as the assigned output device at the other station (I/O mapping).

The I/O MAP address may only appear once in the network. Exception: Outputs with the same address can occur multiple times in different stations on the network.

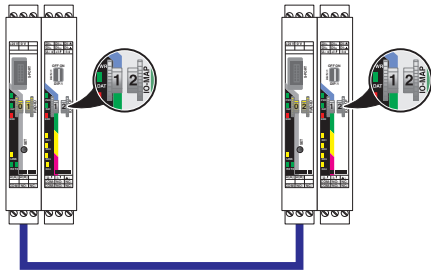

Figure 8 Example: 2 RAD-DAIO6-IFS with the same address

Connect the desired number of I/O extension modules to the front module via the DIN rail connector. Then press the SET button to read the current station configuration.



To apply the configuration, press the SET button for one second in the event of the following changes:

- RAD ID address of front module changed
- I/O MAP address of extension modules changed
- I/O extension module removed
- I/O extension module added

7.5 PSI-CONF configuration and diagnostics software



A PC with a Windows operating system is required in order to use the configuration and diagnostics software.

The PSI-CONF software is required for special settings. It can be downloaded at phoenixcontact.net/product/2702184.

Use the RAD-CABLE-USB USB cable (Order No. 2903447) for configuration and diagnostics.



WARNING: Explosion hazard when used in potentially explosive areas

Do not insert or remove the cable in a potentially explosive atmosphere!

Possible settings via PSI-CONF:

- Configuring the RS-485 interface as desired
- Adjusting timeout times when using additional transmission media in the RS-485 connection (e.g., SHDSL, FO, COMSERVER)

You can connect front modules to a wireless master with firmware version 1.70 or later. If necessary, update the firmware on the wireless master.

7.6 Behavior of the input and output modules in the event of interrupted bus connection

DIP switches on the extension modules can be used to set how the analog and digital outputs should behave in the event of interrupted bus connection.

"HOLD" DIP switch

If the bus connection is interrupted, the outputs of the I/O extension modules retain their last value or state.

"RESET" DIP switch

If the bus connection is interrupted, the outputs of the I/O extension modules are reset (output value is set to 0).

7.7 Copying device settings to new network devices

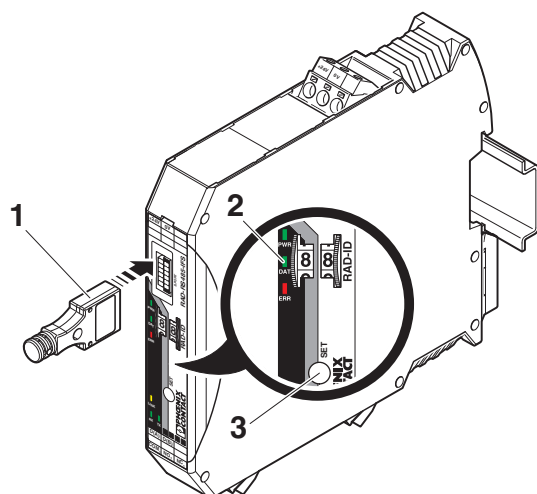

Figure 9 Configuration with memory stick

- 1 Memory stick
- 2 Status LEDs
- 3 SET button

Your individual configuration data can be saved to a memory stick (RAD-MEMORY, see accessories in the "Ordering data" section on page 3), e.g., to transfer the same configuration to other devices.



WARNING: Explosion hazard when used in potentially explosive areas

Do not insert or remove the memory stick in a potentially explosive atmosphere.

Common network parameters:

- Data rate of the RS-485 interface

Individual device parameters:

- Station name
- RAD ID



If an error is detected while saving or subsequently checking the data, the DAT and ERR LEDs flash simultaneously.

Writing a full copy of the individual device parameters and common network parameters to the memory stick (RAD-MEMORY):

- Press and hold down the SET button on the front module for at least six seconds. The LINK LED starts flashing.
- Insert the memory stick in the S-PORT of the front module.
- The copying of parameters is started automatically.
- Wait until the LINK LED is no longer flashing. The write process has been completed.
- Remove the memory stick from the front module.

Reading in common network parameters via the memory stick:

This function enables common network parameters to be read in from the memory stick. This means that all network devices can have the same network parameters.

- Insert the memory stick in the S-PORT of the front module.
- Press and hold down the SET button on the front module for one second.
- Parameter read in is started.
- Read-in has been completed when the DAT LED lights up once. The new parameters are activated.
- Remove the memory stick from the front module.

Reading in a full copy of the individual device parameters and common network parameters via the memory stick:

This function enables all individual device parameters and common network parameters to be read in from the memory stick. This means that a full copy of devices can be created. This can be used, for example, to create a backup copy of a device for device replacement.

- Insert the memory stick in the S-PORT of the front module.
- Press and hold down the SET button on the front module for at least six seconds. The LINK LED starts flashing.
- Parameter read in is started, the DAT LED flashes.
- Wait until the DAT LED is no longer flashing. The read-in has been completed. The new parameters are activated.
- Remove the memory stick from the front module.

8 Application examples

8.1 Multipoint multiplexer via RS-485 (I/O-to-I/O)

The RS-485 front module for existing Radioline extension modules enables easy I/O mapping, even for wired RS-485 2-wire bus systems.

You can therefore reach distances up to 1200 meters directly via RS-485. This range can be increased even further by using additional transmission media:

- FO converter (PSI-MOS device range)
- Ethernet converter (FL COMSERVER...)
- Ethernet extender (TC EXTENDER...)

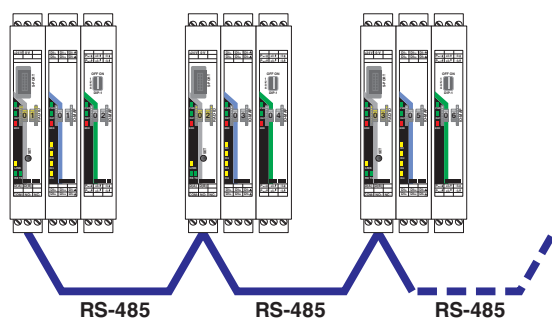

Figure 10 I/O-to-I/O, only RS-485

- Multipoint multiplexer - easy I/O distribution between multiple stations
- Up to 99 stations via RS-485, addressing using yellow thumbwheel
- Easy I/O mapping using the white thumbwheel on the extension modules
- Fast startup via Plug and Play

8.2 Connection to Radioline wireless systems (I/O-to-I/O)

You can connect Radioline RS-485 stations to a Radioline wireless master and thereby extend the wireless network. All devices in the wireless network and in the RS-485 network form one system. All stations are addressed uniquely using the yellow thumbwheel.

The I/O signals can be distributed easily between all stations, regardless of the medium used.

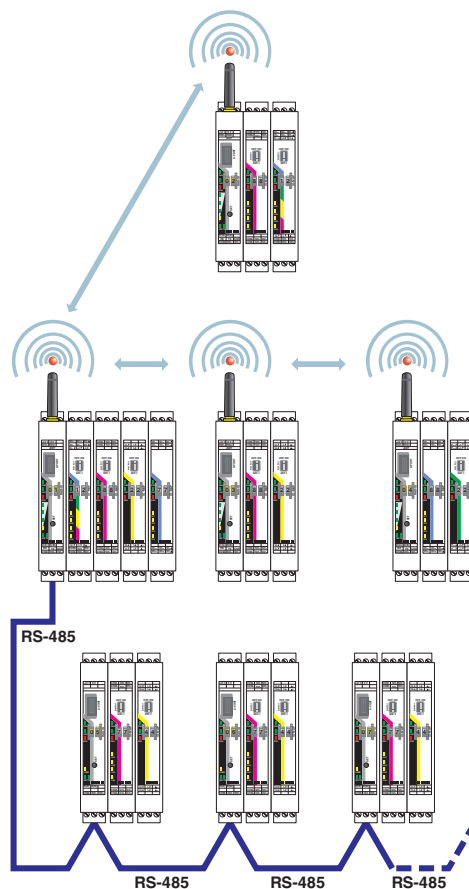

Figure 11 I/O-to-I/O, wireless, and RS-485

- Cross-media distribution of I/O signals
- Up to 250 stations in total: 98 RS-485 stations and 152 wireless stations
- Easy I/O mapping using the white thumbwheel on the extension modules
- Fast startup via Plug and Play

8.3 Modbus/RTU slave (I/O-to-serial)

You can operate every Radioline station as a Modbus/RTU slave. Simply set the Modbus/RTU address (slave ID) using the yellow thumbwheel.

The internal Modbus register addresses of an RS-485 station are identical to the known register addresses in the Radioline wireless network (PLC/Modbus/RTU mode).

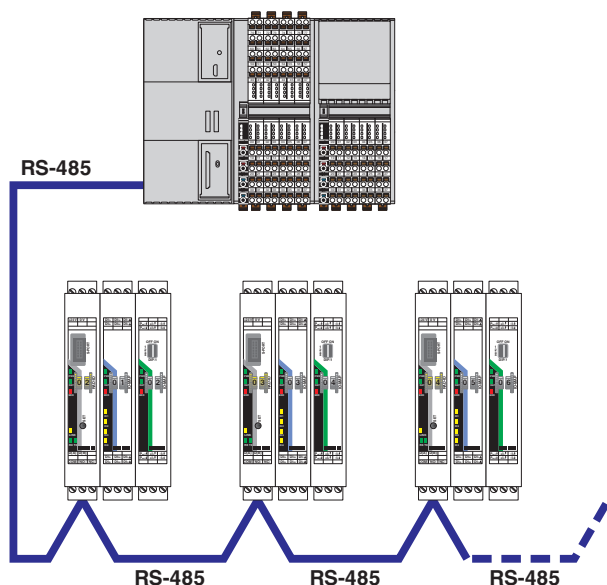

Figure 12 Modbus/RTU slave

- Operation as a bus coupler for Modbus/RTU with Radioline extension modules
- Integration in existing Modbus networks
- As a Modbus slave to any master
- Up to 98 stations per Modbus network
- Fast startup via Plug and Play
- Default setting of the RS-485 interface: 19.2/8/E/1

8.4 Wireless system and RS-485 stations at a Modbus master (I/O-to-serial)

If you operate a Radioline wireless network in PLC/Modbus/RTU mode, the entire wireless network acts like a single Modbus/RTU slave. At the wireless master, you can read or write the I/O signals of all wireless stations from the Modbus table. Set the Modbus address (slave ID) of the wireless master when configuring the wireless network via the PSI-CONF software.

You can extend this wireless network with RS-485 stations and operate them together at any Modbus master. All devices in the RS-485 network are then standard Modbus/RTU slaves. The Modbus address of the RS-485 stations can be set directly at the yellow thumbwheel. The RS-485 station automatically detects the protocol of the master.

The Radioline wireless network and the RS-485 stations are two independent systems. The RAD ID addresses can therefore be repeated in another system.

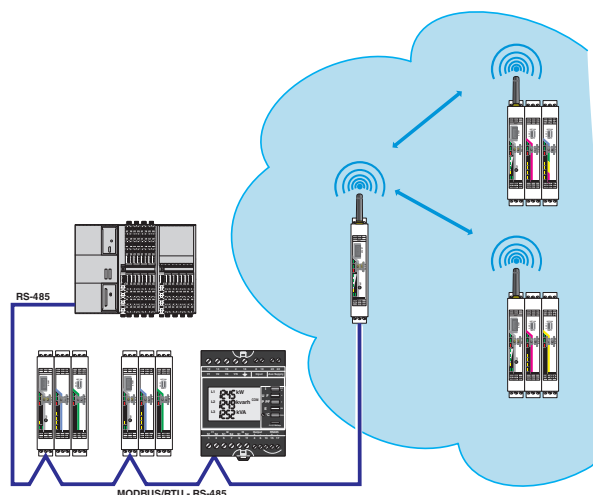

Figure 13 Radioline wireless system and RS-485 stations at a Modbus master (I/O-to-serial)

- Support for all Radioline wireless systems (2.4 GHz, 868 MHz, 900 MHz)
- Integration in existing Modbus networks
- Up to 98 RS-485 stations and up to 250 wireless stations

9 Process data

If you operate an RS-485 station as a Modbus slave, you can read and write the states of the connected I/O extension modules.

Address space		35000															
Modbus function code		fc04															
Address		High byte								Low byte							
		15	14	13	12	11	10	09	08	07	06	05	04	03	02	01	00
35000	Local station	Reserved														IFS	

Bit 00 = error on IFS bus

If an error occurs on the IFS bus, the register value = 1 (e.g., local bus error, as the input or output module is separated from the DIN rail connector).

If no errors are present on the IFS bus, the register value = 0.



The Modbus register addresses of the extension modules can be found in the respective data sheets.

10 Alternative transmission media for increasing the range

The Radioline RS-485 system has a maximum transmission distance of 1200 meters. If this is not sufficient for your application, you can increase the range using various converters.

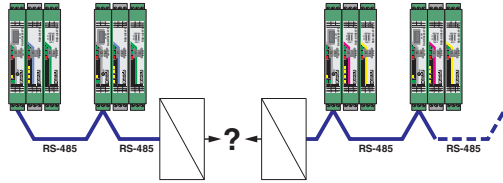

Figure 14 Alternative transmission media for increasing the range

- If using protocol-transparent converters, you must increase the timeout times accordingly. Set the timeout times using the slider in the PSI-CONF software.

10.1 RS-485 repeaters

You can use an RS-485 repeater to open a new segment which itself covers a distance of 1200 meters. This means that you can then cover a total distance of 2400 meters.

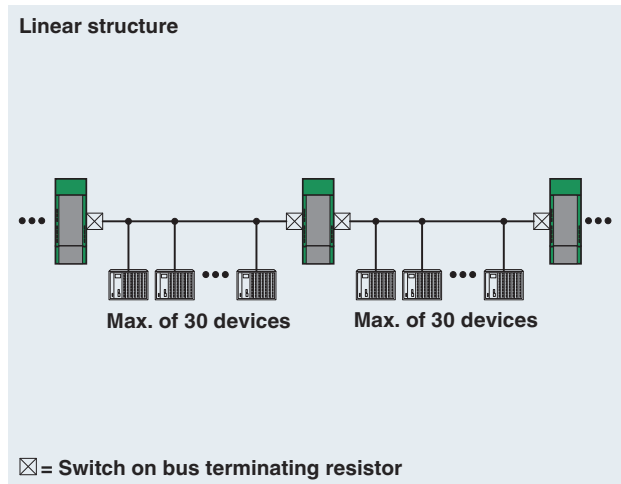

Figure 15 Increasing the range with RS-485 repeaters

RS-485 repeaters	Order No.	Description
PSM-ME-RS485/RS485-P	2744429	Stand-alone device, up to 1.5 Mbps
PSI-REP-RS485W2	2313096	For operation in connection station, up to 500 kbps

10.2 Fiber optic converters

FO converters can be used to extend the RS-485 interface to up to 45 kilometers. In addition, the RS-485 segments are electrically isolated.

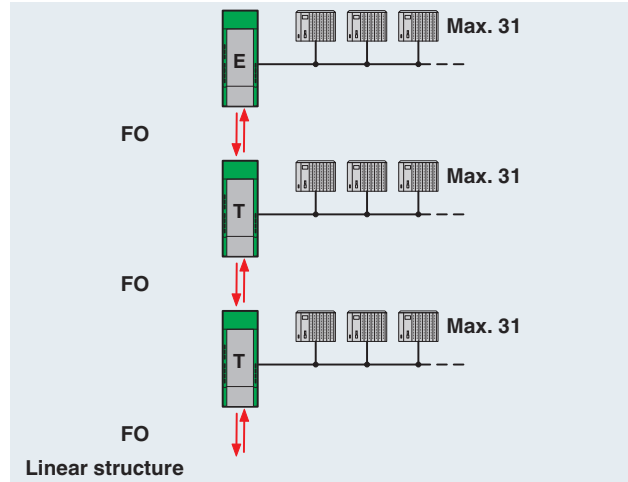

Figure 16 Increasing the range with FO converters

Fiber optic converters	Order No.	Description	Range
PSI-MOS-RS485W2/FO 660 T	2708300	T-coupler, 660 nm, F-SMA	≤800 m
PSI-MOS-RS485W2/FO 660 E	2708313	Terminal device, 660 nm, F-SMA	
PSI-MOS-RS485W2/FO 850 T	2708326	T-coupler, 850 nm, B-FOC (ST®)	≤4.8 km
PSI-MOS-RS485W2/FO 850 E	2708339	Terminal device, 850 nm, B-FOC (ST®)	
PSI-MOS-RS485W2/FO1300 E	2708562	Terminal device, 1300 nm, SC duplex	≤45 km

10.3 SHDSL extender

Use SHDSL extenders to transmit serial data on in-house 2-wire or 4-wire copper cables. Cover distances of up to 20 kilometers with SHDSL at a maximum transmission speed of 2000 kbps.

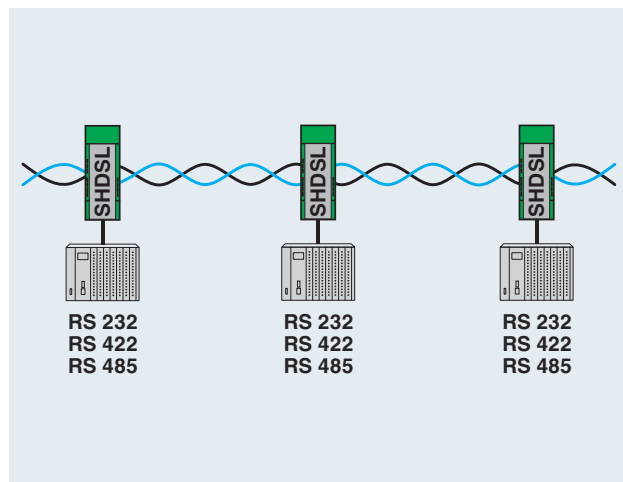

Figure 17 Increasing the range via SHDSL

SHDSL extender	Order No.	Description
PSI-MODEM-SHDSL/SERIAL	2313669	Up to 20 km via 2-wire

10.4 Serial device server

The FL COMSERVER serial device servers convert serial interfaces to Ethernet. You can therefore extend serial interfaces in existing networks or even provide worldwide coverage.

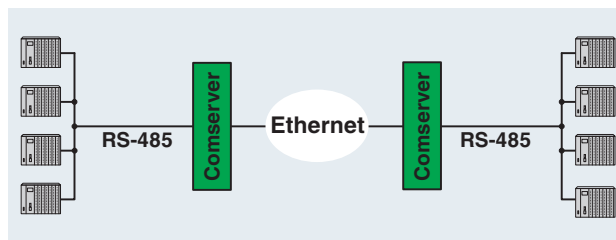

Figure 18 Increasing the range with FL COMSERVER

- Converting a serial interface to Ethernet
- Configuration via web-based management

Serial device server	Order No.	Description
FL COMSERVER BASIC 232/422/485	2313478	For operation at a Radioline master (RAD-ID 01)
FL COMSERVER UNI 232/422/485	2313452	As a Modbus gateway for a Modbus/TCP master

10.5 Transparent wireless path

Serial interfaces also support transparent wireless transmission. Wireless modules with Trusted Wireless 2.0 can be used for larger distances up to several kilometers.

Wireless module	Order No.	Wireless technology	Range
RAD-2400-IFS	2901541	Trusted Wireless 2.0	≤ 5 km*

* The range may be significantly above or below that stated, and depends on the environment, antenna technology, and the product used.

11 Disposal



Dispose of the device separately from other waste, i.e., via an appropriate collection site.



SCATTERGOOD & JOHNSON LTD

ELECTRICAL ENGINEERING & FLUID CONTROL DISTRIBUTORS

Est.1899

At Scattergood & Johnson Ltd, we pride ourselves on being a technical distributor to specialist industries.

Working with a range of quality product suppliers across a number of specialist markets, we are not your average 'box shifter' - we are your technical and supply chain partner.

We fully support every product we sell - for free! Our internal team and external sales engineers can answer any product or application question, no matter the complexity.

Backing up this technical ability is a range of 50,000+ products available from stock for nationwide next day delivery (same day if required!), or you can collect what you need from any of our trade counters around the UK.

Select your specialist interest below to learn more about how we can help.

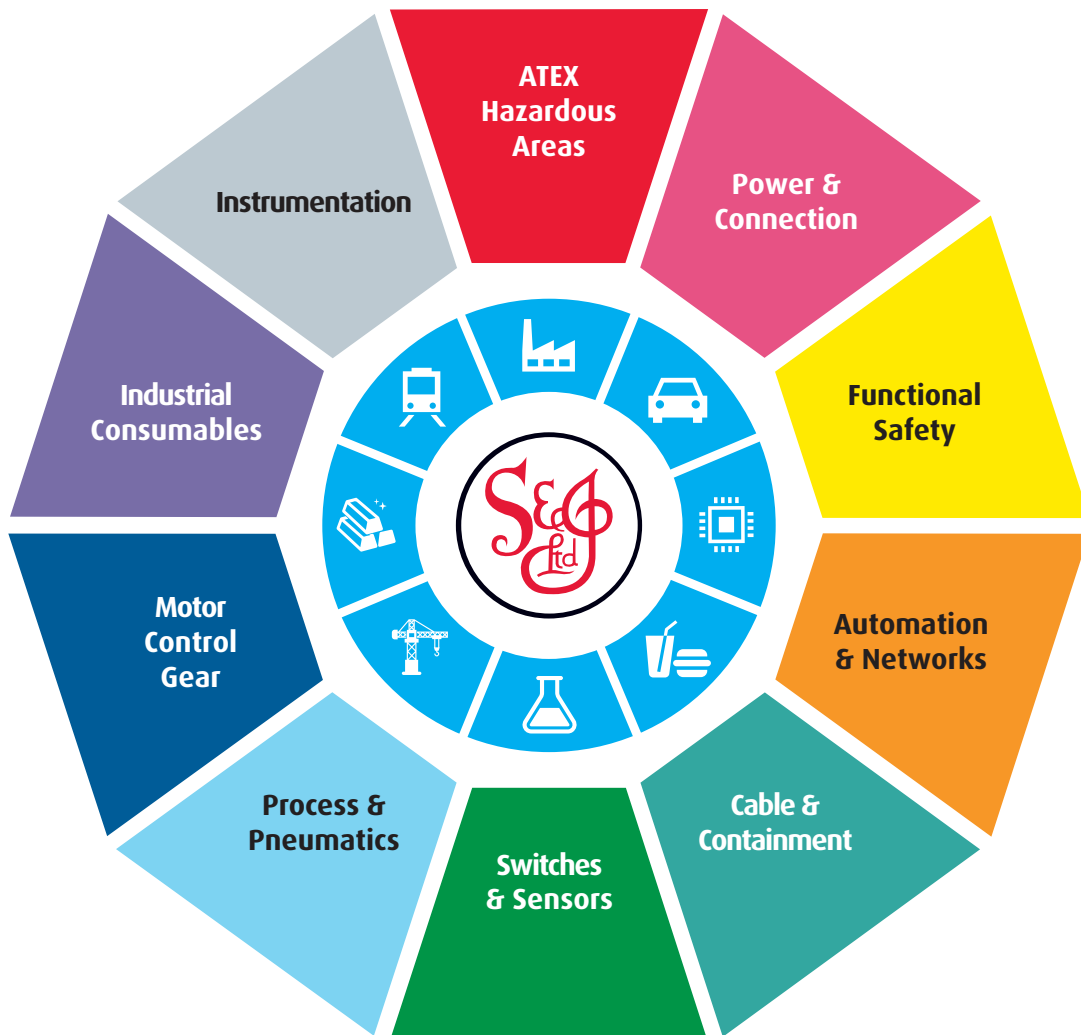

Online, In Branch and On the Road - Scattergood & Johnson Ltd, there when you need us.

www.scatts.co.uk