

RAD-DAIO6-IFS



**I/O extension module,
1 analog input, 1 analog output,
2 digital wide-range inputs and outputs**



Data sheet
104832_en_04

© PHOENIX CONTACT 2019-02-14

1 Description

The **RAD-DAIO6-IFS** I/O extension module can be used in conjunction with Radioline wireless modules and other Interface System (IFS) master devices. In a station structure, you can connect up to 32 I/O extension modules to a wireless module via the DIN rail connector.

The **RAD-DAIO6-IFS** analog/digital I/O extension module is used for processing two digital input/output signals, an analog input signal and an analog output signal.

Features

- Easy and tool-free I/O mapping via thumb wheel on the front
- Modular design via DIN rail connector (hot-swap capable)
- Channel-to-channel electrical isolation
- 2 digital wide-range inputs and outputs (0 ... 250 V AC/DC)
- 1 analog input (alternatively 0/4 ... 20 mA)
- 1 analog output (alternatively 0/4 ... 20 mA, 0 ... 10 V)
- 16-bit resolution of the analog inputs/outputs (accuracy < 0.02%)
- DIP switches for Hold or Reset behavior of outputs
- Loop-power function for passive sensors
- International approvals
- Installation in Ex zone 2



WARNING: Explosion hazard when used in potentially explosive areas

The device is a category 3 item of electrical equipment. Follow the instructions provided here during installation and observe the safety notes.



Make sure you always use the latest documentation.

It can be downloaded at: phoenixcontact.net/product/2901533

2	Table of contents	
1	Description	1
2	Table of contents	2
3	Ordering data	3
4	Technical data	4
5	Derating	9
6	Safety regulations and installation notes.....	10
	6.1 Installation notes	10
	6.2 Installation in Zone 2.....	11
	6.3 UL notes.....	11
7	Installation	12
	7.1 Product description	12
	7.2 Basic circuit diagram	12
	7.3 Configuration	13
	7.4 Display and diagnostic elements	14
	7.5 Analog input	15
	7.6 Analog output	15
	7.7 Digital inputs.....	15
	7.8 Digital outputs.....	15
	7.9 Mounting and removing.....	16
	7.10 Connecting cables	17
8	Application example	17
9	Process data.....	18

3 Ordering data

Description	Type	Order No.	Pcs./Pkt.
Radioline - I/O extension module, 2 digital inputs and outputs (0 ... 250 V AC/DC) and 1 analog input (0/4 ... 20 mA) and output (0/4 ... 20 mA, 0 ... 10 V)	RAD-DAIO6-IFS	2901533	1
Accessories	Type	Order No.	Pcs./Pkt.
DIN rail connector, number of positions: 5, pitch: 3.81 mm, articles with gold-plated contacts, bus connectors for connecting with electronic housings	ME 17,5 TBUS 1,5/ 5-ST-3,81 GN	2709561	10
The FB-MUX/HS/DAIO/PA head station can be used with up to three, 6-channel Digital-Analog-Input-Output modules (RAD-DAIO6-IFS). This configuration can be used as a combination digital and analog I/O solution.	FB-MUX/HS/DAIO/PA	1005329	1
Radioline - 2.4 GHz wireless transceiver with RS-232/RS-485 interface, can be extended with I/O modules, RSMA (female) antenna connection, point-to-point, star, and mesh networks up to 250 stations, range of up to 5 km (with a clear line of sight), for worldwide use	RAD-2400-IFS	2901541	1
Radioline - 900 MHz wireless transceiver with RS-232/485 interface, can be extended with I/O modules, RSMA (female) antenna connection, point-to-point, star, and mesh networks up to 250 stations, range of up to 32 km (line of sight), use in North America	RAD-900-IFS	2901540	1
Radioline - 868 MHz wireless transceiver with RS-232/RS-485 interface, can be extended with I/O modules, RSMA (female) antenna connection, point-to-point, star, and mesh networks up to 99 stations, range of up to 20 km (with a clear line of sight), for use in Europe	RAD-868-IFS	2904909	1
Radioline - RS-485 multipoint multiplexer, can be extended with I/O modules, can be used as Modbus/RTU bus coupler or can be combined with Radioline wireless system, up to 99 stations, range of up to 1.2 km on in-house copper cables	RAD-RS485-IFS	2702184	1
Radioline - 2.4 GHz wireless transceiver with RS-232/RS-485 interface, can be extended with I/O modules, RSMA (female) antenna connection, point-to-point, star, and mesh networks up to 250 stations, range of up to 5 km (with a clear line of sight), for use in Japan	RAD-2400-IFS-JP	2702863	1
Radioline - 900 MHz wireless transceiver with RS-232/485 interface, can be extended with I/O modules, RSMA (female) antenna connection, point-to-point, star, and mesh networks up to 250 stations, range of up to 32 km (line of sight), for use in Australia.	RAD-900-IFS-AU	2702878	1

4 Technical data

Dimensions

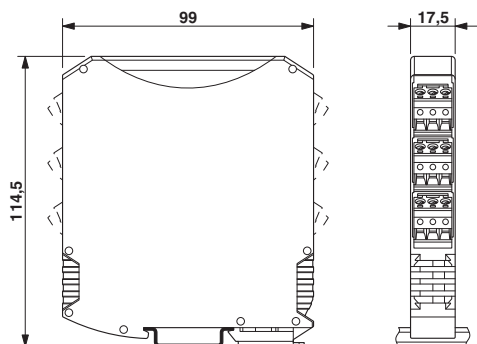

Dimensions W/H/D	17.5 mm / 113 mm / 114.5 mm
------------------	-----------------------------

General data

Overvoltage category	II
Mounting position	any, on standard DIN rail NS 35 in accordance with EN 60715
Degree of protection	IP20
Degree of pollution	2
Type of housing	PA 6.6-FR, green
Flammability rating according to UL 94	V0
MTTF (mean time to failure) Telcordia standard, 25°C temperature, 21% operating cycle (5 days a week, 8 hours a day)	889 Years
MTTF (mean time to failure) Telcordia standard, 40°C temperature, 34.25% operating cycle (5 days a week, 12 hours a day)	391 Years
MTTF (mean time to failure) Telcordia standard, temperature 40 °C, operating cycle 100 % (7 days a week, 24 hours a day)	151 Years

Supply

Supply voltage range	19.2 V DC ... 30.5 V DC (DIN rail connector)
Max. current consumption	≤ 95 mA (At 24 V DC, at 25°C)
Transient surge protection	Yes

Analog input	
Number of inputs	1
Current input signal	0 mA ... 20 mA (can be set via DIP switches) 4 mA ... 20 mA (can be set via DIP switches)
Max. current input signal	22 mA
Input resistance current input	< 70 Ω
Precision	$\leq 0.02\%$ (at 25 °C)
Temperature coefficient, typical	typ. 0.0025 %/K (at -40 °C ... +70 °C)
Supply voltage	≥ 12 V DC (for passive sensors (via terminal PWR1, +I1))
Resolution (bit)	16 bit
Protective circuit	Short-circuit and overload protection
Max. current consumption	< 1 mA
Digital input	
Number of inputs	2
Switching level "1" signal	10 V AC/DC ... 50 V AC/DC (Low-voltage input) 50 V AC/DC ... 250 V AC/DC (High-voltage input)
Switching level "0" signal	0 V AC/DC ... 4 V AC/DC (Low-voltage input) 0 V AC/DC ... 20 V AC/DC (High-voltage input)
Input frequency	≤ 2 Hz
Analog output	
Number of outputs	1
Voltage output signal	0 V ... 10 V
Output signal maximum voltage	approx. 10.83 V
Load	≥ 10 k Ω
Precision	typ. 0.5 % (voltage output)
Current output signal	0 mA ... 20 mA 4 mA ... 20 mA
Output signal maximum current	approx. 21.67 mA
Load	≤ 500 Ω
Precision	$\leq 0.02\%$ (at 25 °C)
Resolution (bit)	16 bit
Temperature coefficient, typical	typ. 0.0025 %/K (at -40 °C ... +70 °C)
Behavior of the outputs (adjustable via DIP switch)	Hold / Reset
Protective circuit	Transient protection of outputs

Relay output	
Number of outputs	2
Contact type	PDT
Contact material	AgSnO ₂
Maximum switching voltage	250 V AC/DC
Min. switching current	≥ 10 mA
Max. switching current	2 A (per channel)
Mechanical service life	1x 10 ⁷ cycles
Electrical service life	2x 10 ⁵ cycles (At 2 A, 250 V AC, cosφ 0.4) 2x 10 ⁵ cycles (At 1 A, 24 V DC, L/R = 48 ms)
Maximum switching frequency	2 Hz
Switching capacity	120 W (24 V DC) 120 W (30 V DC) 20 W (48 V DC) 18 W (60 V DC) 22 W (110 V DC) 40 W (220 V DC) 42 W (250 V DC) 1250 VA
Behavior of the outputs (adjustable via DIP switch)	Hold / Reset

Electrical isolation	
Digital I/O	300 V (Rated insulation voltage (in each case between the digital inputs // digital outputs // TBUS supply, reinforced insulation according to EN 61010))
Analog I/O	50 V (Rated insulation voltage (in each case between the TBUS analog inputs / analog outputs / supply, reinforced insulation according to EN 61010))
Digital/Analog I/O	300 V (Rated insulation voltage (in each case between the digital inputs and outputs and between the analog inputs and outputs, reinforced insulation according to EN 61010))

Test voltage	
Digital I/O	2.5 kV AC (50 Hz, 1 min.)
Analog I/O	1.5 kV AC (50 Hz, 1 min.)

Connection data	
Connection method	Screw connection
Conductor cross section, solid	0.2 mm ² ... 2.5 mm ²
Conductor cross section, flexible	0.2 mm ² ... 2.5 mm ²
Conductor cross section AWG/kcmil	24 ... 14
Stripping length	7 mm
Tightening torque	0.6 Nm

Status indication

Status display	Green LED (supply voltage, PWR) Green LED (bus communication, DAT) Red LED (periphery error, ERR) Yellow LED (digital input, DI1) Yellow LED (digital input, DI2) Yellow LED (digital output, DO1) Yellow LED (digital output, DO2)
----------------	---

Ambient conditions

Ambient temperature (operation)	-40 °C ... 70 °C (>55°C derating) -40 °F ... 158 °F (>131°F derating)
Ambient temperature (storage/transport)	-40 °C ... 85 °C -40 °F ... 185 °F
Permissible humidity (operation)	20 % ... 85 %
Permissible humidity (storage/transport)	20 % ... 85 %
Altitude	2000 m
Vibration (operation)	in accordance with IEC 60068-2-6: 5g, 10 Hz ... 150 Hz
Shock	16g, 11 ms

Operating conditions for the extended temperature range (+55 °C ... 70 °C)

No function restrictions for the extended temperature range if you keep a minimum distance of 17.5 mm between the modules. The minimum distance is the width of a DIN rail connector.

Otherwise please observe the following restrictions:

- Do not use the analog loop-powered output (PWR1).
- Only use the analog voltage output (U1).
- Use two of the four possible digital inputs/outputs, maximum.

Individual operating conditions on request.

Certification

Conformance	CE-compliant EAC
ATEX Please follow the special installation instructions in the documentation!	⊕ II 3 G Ex nA nC IIC T4 Gc (IBExU 15 ATEX B008 X)
IECEX	Ex nA nC IIC T4 Gc (IECEX IBE 13.0019X)
UL, USA/Canada	UL 508 Listed Class I, Div. 2, Groups A, B, C, D T4A Class I, Zone 2, IIC T4
Noxious gas test	ISA-S71.04-1985 G3 Harsh Group A

Conformance

EMC directive 2014/30/EU	EN 61000-6-2; EN 61000-6-4
Ex directive (ATEX)	EN 60079-0; EN 60079-15

Tolerances influenced by electromagnetic interference		
Type of electromagnetic interference	Typical deviation of the measuring range final value (current input)	
-	Relative	Absolute
Electromagnetic fields according to EN 61000-4-3/IEC 61000-4-3	< ±0.2 %	±40 µA
Conducted interference according to EN 61000-4-6/IEC 61000-4-6	< ±0.2 %	±40 µA
Fast transients (burst) according to EN 61000-4-4/IEC 61000-4-4	< ±0.2 %	±40 µA

Tolerances influenced by electromagnetic interference		
Type of electromagnetic interference	Typical deviation of the measuring range final value (current output)	
-	Relative	Absolute
Electromagnetic fields; 10 V/m according to EN 61000-4-3/IEC 61000-4-3	< ±2.5 %	±500 µA
Electromagnetic fields; 3 V/m according to EN 61000-4-3/IEC 61000-4-3	< ±0.2 %	±40 µA
Conducted interference according to EN 61000-4-6/IEC 61000-4-6	< ±0.2 %	±40 µA
Fast transients (burst) according to EN 61000-4-4/IEC 61000-4-4	< ±0.2 %	±40 µA

5 Derating

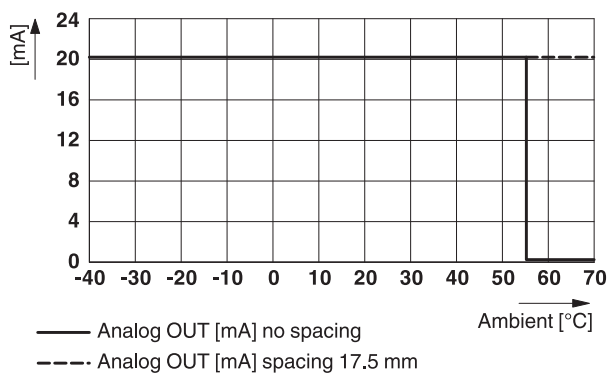
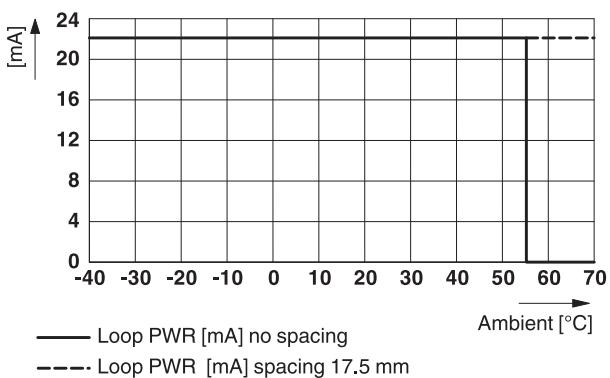
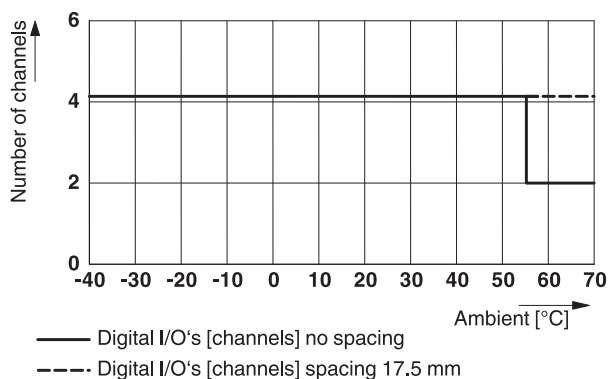

6 Safety regulations and installation notes



WARNING: Risk of electric shock

During operation, certain parts of this device may carry hazardous voltages. Disregarding this warning may result in damage to equipment and/or serious personal injury.

- For applications with high operating voltages, ensure sufficient distance or insulation and provide shock protection.
- Provide a switch/circuit breaker close to the device, which is labeled as the disconnect device for this device or the entire control cabinet.
- Disconnect the device from all power sources during maintenance work and configuration (the device can remain connected to SELV or PELV circuits).
- The housing of the device provides a basic insulation against the neighboring devices, for 300 V eff. If several devices are installed next to each other, this has to be taken into account, and additional insulation has to be installed if necessary. If the neighboring device is equipped with basic insulation, no additional insulation is necessary.
- Always use the same phase for digital inputs and digital outputs.
Maximum isolating voltage: 300 V.

6.1 Installation notes



WARNING:

Observe the following safety notes when using the device.

- The category 3 device is designed for installation in zone 2 potentially explosive areas. It meets the requirements of EN 60079-0:2012+A11:2013 and EN 60079-15:2010.
- Installation, operation, and maintenance may only be carried out by qualified electricians. Follow the installation instructions as described.
- When installing and operating the device, the applicable regulations and safety directives (including national safety directives), as well as general technical regulations, must be observed. The technical data is provided in the package slip and on the certificates (conformity assessment, additional approvals where applicable).
- The device must not be opened or modified. Do not repair the device yourself, replace it with an equivalent device. Repairs may only be carried out by the manufacturer. The manufacturer is not liable for damage resulting from violation.
- The IP20 protection (IEC 60529/EN 60529) of the device is intended for use in a clean and dry environment. The device must not be subject to mechanical strain and/or thermal loads, which exceed the limits described.
- To protect the device against mechanical or electrical damage, install it in a suitable housing with appropriate degree of protection as per IEC 60529.
- The device is not designed for use in atmospheres with a danger of dust explosions.
- If dust is present, it is necessary to install into a suitable approved housing, whereby the surface temperature of the housing must be taken into consideration.

6.2 Installation in Zone 2



WARNING: Explosion hazard when used in potentially explosive areas

Please make sure that the following notes and instructions are observed.

- Observe the specified conditions for use in potentially explosive areas! Install the device in a suitable, approved housing that meets the requirements of IEC/EN 60079-15 and has at least IP54 protection. Also observe the requirements of IEC/EN 60079-14.
- In zone 2, only connect devices to the supply and signal circuits that are suitable for operation in the Ex zone 2 and the conditions at the installation location.
- In potentially explosive areas, terminals may only be snapped onto or off the DIN rail connector and wires may only be connected or disconnected when the power is switched off.
- The switches of the device that can be accessed may only be actuated when the power supply to the device is disconnected.
- The device must be stopped and immediately removed from the Ex area if it is damaged, was subject to an impermissible load, stored incorrectly or if it malfunctions.

6.3 UL notes



WARNING: Explosion hazard when used in potentially explosive areas

Please make sure that the following notes and instructions are observed.

INDUSTRIAL CONTROL EQUIPMENT FOR HAZARDOUS LOCATIONS 45FP

- A This equipment is suitable for use in Class I, Zone 2, IIC T4 and Class I, Division 2, Groups A, B, C,D T4A hazardous locations or non-hazardous locations only.
- B **WARNING - EXPLOSION HAZARD - DO NOT DISCONNECT EQUIPMENT UNLESS POWER HAS BEEN SWITCHED OFF OR THE AREA IS KNOWN TO BE NON-HAZARDOUS.**
- C **WARNING - EXPLOSION HAZARD - SUBSTITUTION OF COMPONENTS MAY IMPAIR SUITABILITY FOR CLASS 1, DIVISION 2.**
- D These devices are open-type devices that are to be installed in an enclosure suitable for the environment that is only accessible with the use of a tool.
- E **WARNING - Exposure to some chemicals may degrade the sealing properties of materials used in relays within this device.**

7 Installation



NOTE: electrostatic discharge!
 Electrostatic discharge can damage or destroy components.

- When handling the device, observe the necessary safety precautions against electrostatic discharge (ESD) according to EN 61340-5-1 and IEC 61340-5-1.

7.1 Product description

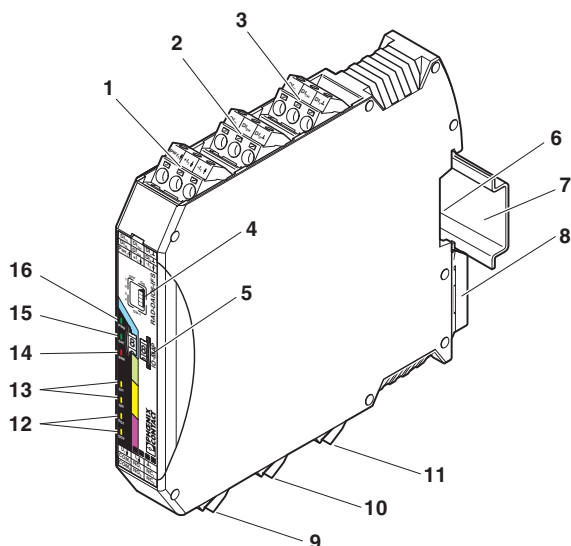

Figure 1 Function elements

Pos.	Terminal block	Designation
1	3.1 / 3.2 / 3.3	Analog inputs for 2-, 3-, 4-wire measuring transducers
2	2.1 / 2.2 / 2.3	Digital input as wide-range input
3	1.1 / 1.2 / 1.3	Digital input as wide-range input
4		DIP switches for input/output configuration
5		White thumbwheel for setting the I/O-MAP address
6		Connection option for DIN rail connector
7		DIN rail
8		Metal foot catch for DIN rail fixing
9	4.1 / 4.2 / 4.3	Analog output, alternatively current/voltage
10	5.1 / 5.2 / 5.3	Relay output with PDT contact (floating)
11	6.1 / 6.2 / 6.3	Relay output with PDT contact (floating)
12		Status LEDs for the digital outputs DO1...DO2
13		Status LEDs for the digital inputs DI1...DI2
14		ERR status LED, red (communication error)
15		DAT status LED, green (bus communication)
16		PWR status LED, green (supply voltage)

7.2 Basic circuit diagram

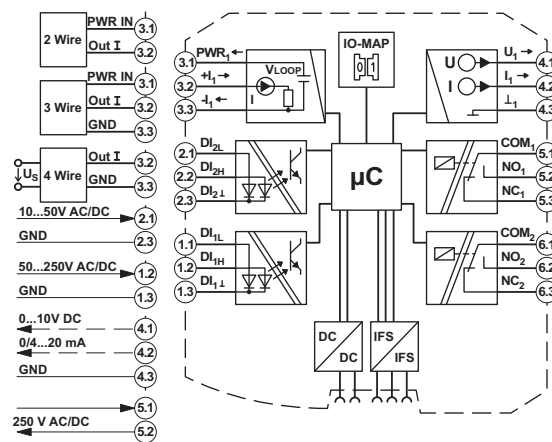

Figure 2 Basic circuit diagram

7.3 Configuration

The DIP switches on the front can be used to configure the input signals ranges (0 ... 20 mA or 4 ... 20 mA). You can also set the behavior of the outputs in the event of an error, e.g., interruption of the wireless connection.

For the analog output you can either select the “reset” option (output value set to 0 = Reset) or the “hold last value” option (Hold). For the digital outputs you can select the “reset” option (relay drops out = Reset) or the “hold last valid state” option (Hold).

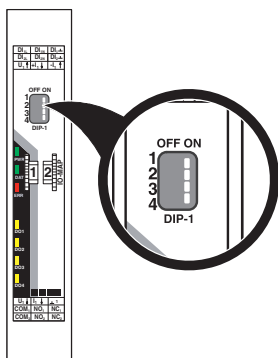

Figure 3 DIP switches

Input/output	Configuration	DIP switch			
		1	2	3	4
Analog IN	0 ... 20 mA	OFF			
Analog IN	4 ... 20 mA	ON			
Analog OUT	Reset		OFF		
Analog OUT	Hold		ON		
Digital OUT1	Reset			OFF	
Digital OUT1	Hold			ON	
Digital OUT2	Reset				OFF
Digital OUT2	Hold				ON

I/O MAP address

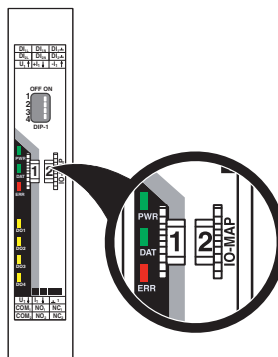

Figure 4 Thumb wheel

Use the thumbwheel to set the I/O-MAP address. The extension module in the Radioline wireless system is addressed using the I/O-MAP address.

On the entire wireless network, addresses 1 to 99 (I/O MAP) (maximum) may be assigned for the I/O extension modules.

Thumbwheel	Description
01 - 99	I/O MAP address
00	Delivery state
** , 1* - 9*	Setting not permitted
*1 - *9	Interface System slave address, for use with other Interface System (IFS) master devices

Wireless module in I/O data mode

An input/output device must be provided with the same setting (I/O-MAP address) as the assigned input/output device at the other wireless station (I/O mapping).

Each I/O-MAP address must only be assigned to one device pair.

Example:	I/O MAP address
RAD-DAIO6-IFS	02
RAD-DAIO6-IFS	02

Only the RAD-DAIO6-IFS module can be assigned to the RAD-DAIO6-IFS module.

Wireless module in PLC/Modbus RTU mode

Each I/O MAP address may only appear once in the network.

Input and output data is stored in a Modbus Memory Map in the master wireless module. You can read or write the process data via the serial interface of the master wireless module (RAD ID = 01) using Modbus RTU commands.

7.4 Display and diagnostic elements

The I/O extension module uses a total of seven LEDs to indicate the operating states.

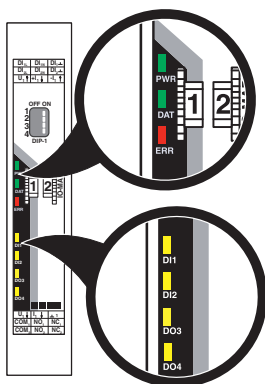

Figure 5 Display and diagnostic elements

PWR-LED

The green PWR LED indicates the supply voltage status.

Off	no supply voltage
On	supply voltage OK

DAT-LED

The green DAT LED indicates the bus communication status.

Off	no communication
Flashing	configuration and addressing mode
On	cyclic data communication

ERR-LED

The red ERR LED indicates the error status, e.g., no corresponding output module found (e.g., incorrect addressing).

Off	no error
Flashing	Slow (1.4 Hz) I/O-MAP address changed
Fast (2.8 Hz)	Wireless module in I/O data mode (wire in/wire out)

Missing input module,
no bus communication

Wireless module in PLC/Modbus RTU mode

No Modbus communication (safe state of outputs, depending on DIP switch setting)

On	Critical internal error
----	-------------------------

DI1 / DI2

The yellow DI1/DI2 LEDs indicate the status of the digital inputs.

DO1 / DO2

The yellow DO1/DO2 LEDs indicate the status of the digital outputs.

7.5 Analog input

The analog input of the extension module is able to process standard signals (0/4...20 mA).

All the inputs are electrically isolated from one another, from the supply voltage (via bus foot), and from other electronic components.

A supply voltage of 12 V DC, minimum, is available at the connection terminal block (PWR₁) for the use of passive sensors (1 in Figure 1, connection assignment see Figure 2).

7.6 Analog output

The analog output of the extension module (9 in Figure 1) is designed as an active output.

All the outputs are electrically isolated from one another, from the supply voltage (via bus foot), and from other electronic components.

The output signal can be selected either as a current signal (0/4...20 mA) or as a voltage signal (0...10 V).

7.7 Digital inputs

The digital inputs are electrically isolated (reinforced insulation) from one another, from the supply voltage (via the bus foot), and from other electronic components.

The two digital inputs of the device are used to process low voltages in the 0...50 V AC/DC range and high voltages in the 50...250 V AC/DC range.

7.8 Digital outputs

The two digital outputs of the extension module (10, 11 in Figure 1) are designed as floating relay contacts (PDT).
Switching capacity: 2 A at 250 V AC / 24 V DC.

The digital outputs are electrically isolated (reinforced insulation) from one another, from the supply voltage (via the bus foot), and from other electronic components.

7.9 Mounting and removing

Connection station with I/O extension modules

Up to 32 different I/O extension modules can be connected to every wireless module via the DIN rail connector (see accessories). Data is transmitted and power is supplied to the I/O extension modules via the bus foot.

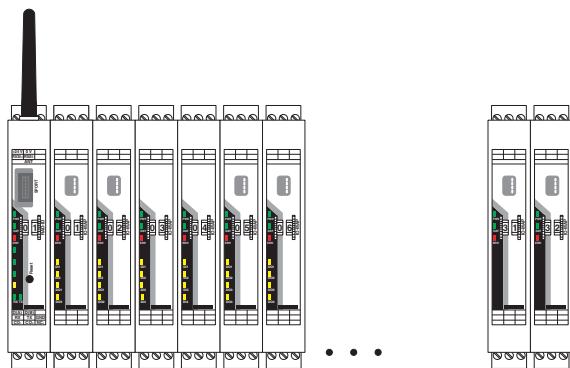

Figure 6 Radioline connection station with up to 32 I/O extension modules



Only mount the I/O extension modules to the right of the wireless module.

Mounting

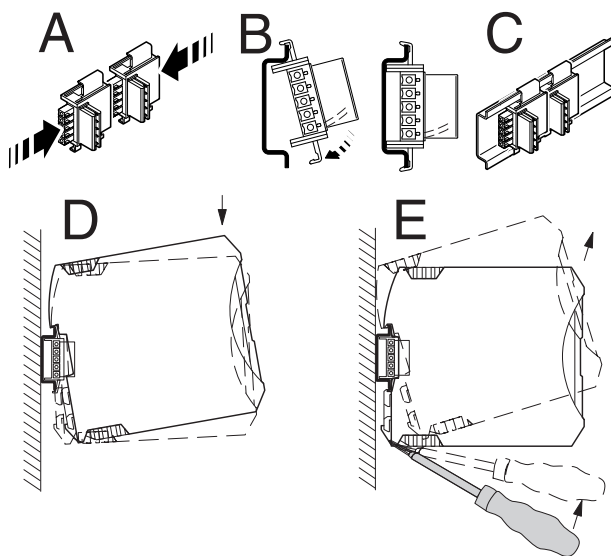

Figure 7 Mounting and removing

When using the device in a connection station, use the 17.5 mm wide DIN rail connector supplied. Only use the DIN rail connector in connection with 24 V DC devices.



Outside the Ex area, module extension or module replacement is also possible during operation.

- Connect the DIN rail connectors together for a connection station.
- Push the connected DIN rail connectors into the DIN rail.
- Place the device onto the DIN rail from above. Ensure the device and DIN rail connector are aligned correctly.
- Holding the device by the housing cover, carefully push the device towards the mounting surface so that the device bus connector is securely fixed onto the DIN rail connector.
- Once the snap-on foot has been audibly snapped onto the DIN rail, check that it is fixed securely. The device is only mechanically secured via the DIN rail.
- Connect the desired number of I/O extension modules to the wireless module via the DIN rail connector.
- In order to meet the requirements for the protection class, install the device in suitable housing.
- During startup, check that the device is operating, wired, and marked correctly.
- You can establish a connection between two DIN rail connectors using MINI COMBICON connectors: MC 1,5/5-ST-3,81 (female, 1803604); IMC 1,5/5-ST-3,81 (male, 1857919).

Removing

- Use a suitable screwdriver to release the locking mechanism on the snap-on foot of the device.
- Hold onto the device by the housing cover and carefully tilt it upwards.
- Carefully lift the device off the DIN rail connector and the DIN rail.

7.10 Connecting cables

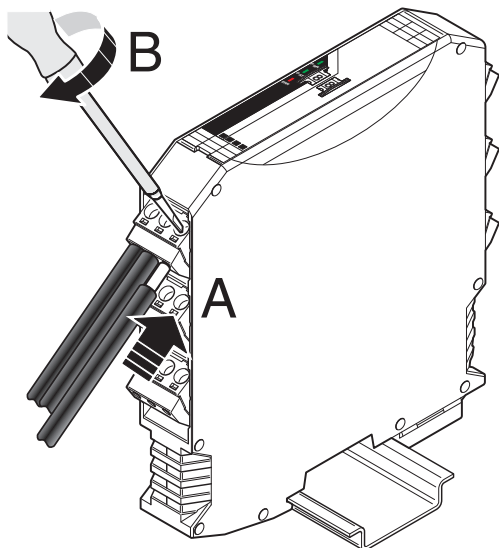

Figure 8 Connecting cables

- Crimp ferrules to the wires.
Permissible cable cross section: 0.2...2.5 mm².
- Insert the wire with ferrule into the corresponding connection terminal block.
- Use a screwdriver to tighten the screw in the opening above the connection terminal block.
Tightening torque: 0.6 Nm

8 Application example

Level measurement and passive PLC input card:

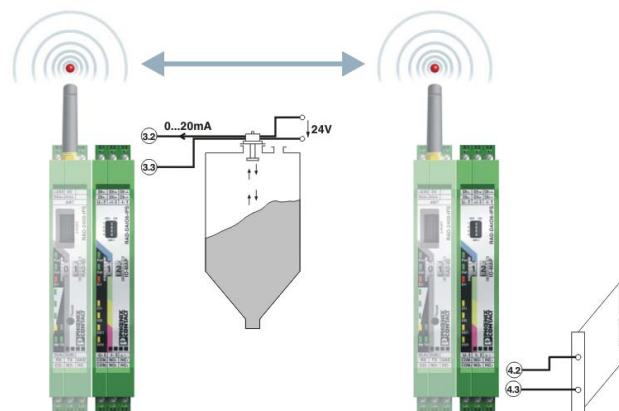

Figure 9 Level measurement

9 Process data

You can read or write the process data via the serial interface of the master wireless module (RAD ID = 01) using Modbus RTU commands.

With the PSI-CONF software, you can set the wireless module's network application to "PLC/Modbus RTU mode".

I/O module	RAD-DAIO6-IFS	RAD-DAIO6-IFS
Module type	60 _{hex}	60 _{hex}
Number of registers	03 _{hex} (inputs)	03 _{hex} (outputs)
Address space	30xx0 ... 30xx2	40xx0 ... 40xx2
Modbus function code	fc04	fc 03, 16

xx = I/O MAP address set using the white thumbwheel

30xx0, 40xx0	Module type and currentness of data															
	15	14	13	12	11	10	09	08	07	06	05	04	03	02	01	00
	Y Module type															

Register values:

Module type If the module type in the register is invalid or unavailable, then the register value is 0

Currentness of data Y = Currentness of data, bit 8
If the data in the register is not up-to-date, then the register value is 1.

If process data has been written to one of the registers, bit 8 in 40xx0 is set to 0. The value in register 40xx0 then remains 0 for the entire operating time of the device.

This is the case if, for example, the wireless connection fails.

The IN process data is retained in the Modbus table, but is no longer updated.

30xx1		Digital inputs															
		15	14	13	12	11	10	09	08	07	06	05	04	03	02	01	00
																DI 2	DI 1
Terminal point																	
																2.x	1.x

30xx2		Analog input (terminal point 3.x)															
		15	14	13	12	11	10	09	08	07	06	05	04	03	02	01	00
AI1																	

30xx3 ... 30xx9	Reserved
-----------------	----------

40xx1		Digital outputs															
		15	14	13	12	11	10	09	08	07	06	05	04	03	02	01	00
																DO 2	DO 1
Terminal point																	
																6.x	5.x

40xx2		Analog output (terminal point 4.x)															
		15	14	13	12	11	10	09	08	07	06	05	04	03	02	01	00
AO1																	
Terminal point																	
																4.x	

40xx3 ... 40xx9	Reserved
-----------------	----------

Illustration of analog values				
Data word		0 ... 20 mA	4 ... 20 mA	0 ... 10 V
hex	dec			
0000	0	0 mA	-	0 V
1770	6000	4 mA	4 mA	2 V
7530	30000	20 mA	20 mA	10 V
7F00	32512	21.67 mA	21.67 mA	10.84 V
8001	Overrange	> 21.67	> 21.67	-
8002	Open circuit	-	<3.2 mA	-
8080	Underrange	< 0 mA	-	-



SCATTERGOOD & JOHNSON LTD

ELECTRICAL ENGINEERING & FLUID CONTROL DISTRIBUTORS

Est.1899

At Scattergood & Johnson Ltd, we pride ourselves on being a technical distributor to specialist industries.

Working with a range of quality product suppliers across a number of specialist markets, we are not your average 'box shifter' - we are your technical and supply chain partner.

We fully support every product we sell - for free! Our internal team and external sales engineers can answer any product or application question, no matter the complexity.

Backing up this technical ability is a range of 50,000+ products available from stock for nationwide next day delivery (same day if required!), or you can collect what you need from any of our trade counters around the UK.

Select your specialist interest below to learn more about how we can help.



Online, In Branch and On the Road - Scattergood & Johnson Ltd, there when you need us.

www.scatts.co.uk