

RAD-DI4-IFS



I/O extension module, 4 digital wide-range inputs

Data sheet
104833_en_03

© PHOENIX CONTACT 2016-08-29

1 Description

The **RAD-DI4-IFS** I/O extension module can be used in conjunction with Radioline wireless modules and other Interface System (IFS) master devices. In a station structure, you can connect up to 32 I/O extension modules to a wireless module via the DIN rail connector.

The **RAD-DI4-IFS** digital I/O extension module is used for processing four input signals. Each input is wired either with a low voltage signal or a high voltage signal.

Features

- Easy and tool-free I/O mapping via thumb wheel on the front
- Modular design via DIN rail connector (hot-swap capable)
- Channel-to-channel electrical isolation
- 4 digital wide-range inputs (0 ... 250 V AC/DC)
- International approvals
- Installation in Ex zone 2



WARNING: Explosion hazard when used in potentially explosive areas

The device is a category 3 item of electrical equipment. Follow the instructions provided here during installation and observe the safety notes.



Make sure you always use the latest documentation.
It can be downloaded from the product at phoenixcontact.net/products.

2	Table of contents	
1	Description	1
2	Table of contents	2
3	Ordering data	3
4	Technical data	4
5	Safety regulations and installation notes.....	7
	5.1 Installation notes	7
	5.2 Installation in Zone 2.....	8
	5.3 UL Notes	8
6	Installation	9
	6.1 Structure	9
	6.2 Basic circuit diagram	9
	6.3 I/O MAP address in the Radioline wireless system	10
	6.4 Display and diagnostic elements	11
	6.5 Digital inputs.....	11
	6.6 Mounting and removing.....	12
	6.7 Connecting cables	13
7	Process data.....	13

3 Ordering data

Description	Type	Order No.	Pcs./Pkt.
Digital I/O extension module with 4 digital inputs (0...250 V AC/DC), with screw connection, incl. DIN rail connector	RAD-DI4-IFS	2901535	1
Accessories	Type	Order No.	Pcs./Pkt.
2400 MHz wireless transceiver with RS-232, RS-485 2-wire interface, expandable with I/O extension modules, with screw connection, antenna connection: RSMA (female), including DIN rail connector, without antenna	RAD-2400-IFS	2901541	1
868 MHz wireless transceiver with RS-232, RS-485 2-wire interface, expandable with I/O extension modules, with screw connection, antenna connection: RSMA (female), including DIN rail connector, without antenna.	RAD-868-IFS	2904909	1
Bidirectional, Radioline 900 MHz transceiver for wireless transmission of serial and I/O data	RAD-900-IFS	2901540	1
DIN rail connector for DIN rail mounting. Universal for TBUS housing. Gold-plated contacts, 5-pos. Header, Nominal current: 8 A, Number of positions: 5, Pitch: 3.81 mm, Articles with gold-plated contacts, bus connectors for connecting with electronic housings	ME 17,5 TBUS 1,5/ 5-ST-3,81 GN	2709561	10
Digital I/O extension module with 4 digital relay outputs (5 A, 250 V AC/ 24 V DC), with screw connection, incl. DIN rail connector	RAD-DOR4-IFS	2901536	1
Multipoint multiplexer for RS-485 bus system, can be extended with I/O extension modules. Can be used as Modbus RTU bus coupler or combined with Radioline wireless system, screw connection. Up to 99 stations, including DIN rail connector	RAD-RS485-IFS	2702184	1

4 Technical data

Dimensions

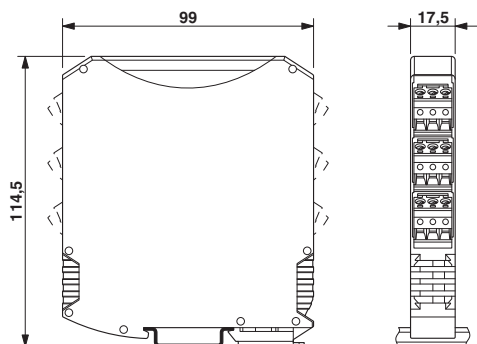

Dimensions W/H/D	17.5 mm / 99 mm / 114.5 mm
------------------	----------------------------

General data

Overvoltage category	II
Mounting position	any, on standard DIN rail NS 35 in accordance with EN 60715
Degree of protection	IP20
Degree of pollution	2
Type of housing	PA 6.6-FR, green
Flammability rating according to UL 94	V0
MTTF (mean time to failure) Telcordia standard, 25°C temperature, 21% operating cycle (5 days a week, 8 hours a day)	1766 Years
MTTF (mean time to failure) Telcordia standard, 40°C temperature, 34.25% operating cycle (5 days a week, 12 hours a day)	653 Years
MTTF (mean time to failure) Telcordia standard, temperature 40 °C, operating cycle 100 % (7 days a week, 24 hours a day)	250 Years

Supply

Supply voltage range	19.2 V DC ... 30.5 V DC (DIN rail connector)
Max. current consumption	≤ 11 mA (At 24 V DC, at 25°C)
Transient surge protection	Yes

Digital input

Number of inputs	4
Input signal Voltage	0 V AC/DC ... 250 V AC/DC
Switching level "1" signal	10 V AC/DC ... 50 V AC/DC (Low-voltage input)
Switching level "0" signal	0 V AC/DC ... 4 V AC/DC (Low-voltage input)
Switching level "1" signal	50 V AC/DC ... 250 V AC/DC (High-voltage input)
Switching level "0" signal	0 V AC/DC ... 20 V AC/DC (High-voltage input)
Input frequency	≤ 2 Hz
Max. current consumption	< 1 mA

Electrical isolation

Digital I/O	300 V (Rated insulation voltage (in each case between the digital inputs // TBUS supply, reinforced insulation according to EN 61010))
	300 V (Rated insulation voltage (to adjacent devices, basic insulation in accordance with EN 61010))

Test voltage

Digital I/O	2.5 kV AC (50 Hz, 1 min.)
-------------	---------------------------

Connection data

Connection method	Screw connection
Conductor cross section, solid	0.2 mm ² ... 2.5 mm ²
Conductor cross section, flexible	0.2 mm ² ... 2.5 mm ²
Conductor cross section AWG/kcmil	24 ... 14
Stripping length	7 mm
Tightening torque	0.6 Nm

Status indication

Status display	Green LED (supply voltage, PWR) Green LED (bus communication, DAT) Red LED (periphery error, ERR) Yellow LED (digital input, DI1) Yellow LED (digital input, DI2) Yellow LED (digital input, DI3) Yellow LED (digital input, DI4)
----------------	---

Ambient conditions

Ambient temperature (operation)	-40 °C ... 70 °C -40 °F ... 158 °F
Ambient temperature (storage/transport)	-40 °C ... 85 °C -40 °F ... 185 °F
Permissible humidity (operation)	20 % ... 85 %
Permissible humidity (storage/transport)	20 % ... 85 %
Altitude	2000 m
Vibration (operation)	in accordance with IEC 60068-2-6: 5g, 10 Hz ... 150 Hz
Shock	16g, 11 ms

Certification

Conformance	CE-compliant EAC
ATEX Please follow the special installation instructions in the documentation!	⊕ II 3 G Ex nA IIC T4 Gc (IBExU 15 ATEX B008 X)
IECEX	Ex nA IIC T4 Gc (IECEX IBE 13.0019X)
UL, USA/Canada	UL 508 Listed Class I, Div. 2, Groups A, B, C, D T4A Class I, Zone 2, IIC T4

Conformance

EMC directive 2014/30/EU	EN 61000-6-2; EN 61000-6-4
Ex directive (ATEX)	EN 60079-0; EN 60079-15

5 Safety regulations and installation notes



WARNING: Risk of electric shock

During operation, certain parts of this device may carry hazardous voltages. Disregarding this warning may result in damage to equipment and/or serious personal injury.

- For applications with high operating voltages, ensure sufficient distance or insulation and provide shock protection.
- Provide a switch/circuit breaker close to the device, which is labeled as the disconnect device for this device or the entire control cabinet.
- Disconnect the device from all power sources during maintenance work and configuration (the device can remain connected to SELV or PELV circuits).
- The housing of the device provides a basic insulation against the neighboring devices, for 300 V eff. If several devices are installed next to each other, this has to be taken into account, and additional insulation has to be installed if necessary. If the neighboring device is equipped with basic insulation, no additional insulation is necessary.

5.1 Installation notes



WARNING:

Observe the following safety notes when using the device.

- The category 3 device is designed for installation in zone 2 potentially explosive areas. It meets the requirements of EN 60079-0:2012+A11:2013 and EN 60079-15:2010.
- Installation, operation, and maintenance may only be carried out by qualified electricians. Follow the installation instructions as described.
- When installing and operating the device, the applicable regulations and safety directives (including national safety directives), as well as general technical regulations, must be observed. The technical data is provided in the package slip and on the certificates (conformity assessment, additional approvals where applicable).
- The device must not be opened or modified. Do not repair the device yourself, replace it with an equivalent device. Repairs may only be carried out by the manufacturer. The manufacturer is not liable for damage resulting from violation.
- The IP20 protection (IEC 60529/EN 60529) of the device is intended for use in a clean and dry environment. The device must not be subject to mechanical strain and/or thermal loads, which exceed the limits described.
- To protect the device against mechanical or electrical damage, install it in a suitable housing with appropriate degree of protection as per IEC 60529.
- The device is not designed for use in atmospheres with a danger of dust explosions.
- If dust is present, it is necessary to install into a suitable approved housing, whereby the surface temperature of the housing must be taken into consideration.

5.2 Installation in Zone 2

**WARNING: Explosion hazard when used in potentially explosive areas**

Please make sure that the following notes and instructions are observed.

- Observe the specified conditions for use in potentially explosive areas! Install the device in a suitable approved housing (with a minimum of IP54 protection) that meets the requirements of EN 60079-15. Observe the requirements of EN 60079-14.
- In zone 2, only connect devices to the supply and signal circuits that are suitable for operation in the Ex zone 2 and the conditions at the installation location.
- In potentially explosive areas, terminals may only be snapped onto or off the DIN rail connector and wires may only be connected or disconnected when the power is switched off.
- The switches of the device that can be accessed may only be actuated when the power supply to the device is disconnected.
- The device must be stopped and immediately removed from the Ex area if it is damaged, was subject to an impermissible load, stored incorrectly or if it malfunctions.

5.3 UL Notes

INDUSTRIAL CONTROL EQUIPMENT FOR HAZARDOUS LOCATIONS 45FP

- A This equipment is suitable for use in Class I, Zone 2, IIC T4 and Class I, Division 2, Groups A, B, C,D T4A hazardous locations or non-hazardous locations only.
- B **WARNING - EXPLOSION HAZARD - DO NOT DISCONNECT EQUIPMENT UNLESS POWER HAS BEEN SWITCHED OFF OR THE AREA IS KNOWN TO BE NON-HAZARDOUS.**
- C **WARNING - EXPLOSION HAZARD - SUBSTITUTION OF COMPONENTS MAY IMPAIR SUITABILITY FOR CLASS 1, DIVISION 2.**
- D These devices are open-type devices that are to be installed in an enclosure suitable for the environment that is only accessible with the use of a tool.
- E **WARNING - Exposure to some chemicals may degrade the sealing properties of materials used in relays within this device.**

6 Installation



NOTE: electrostatic discharge!
 The device contains components that can be damaged or destroyed by electrostatic discharge. When handling the device, observe the necessary safety precautions against electrostatic discharge (ESD) according to EN 61340-5-1 and IEC 61340-5-1.

6.1 Structure

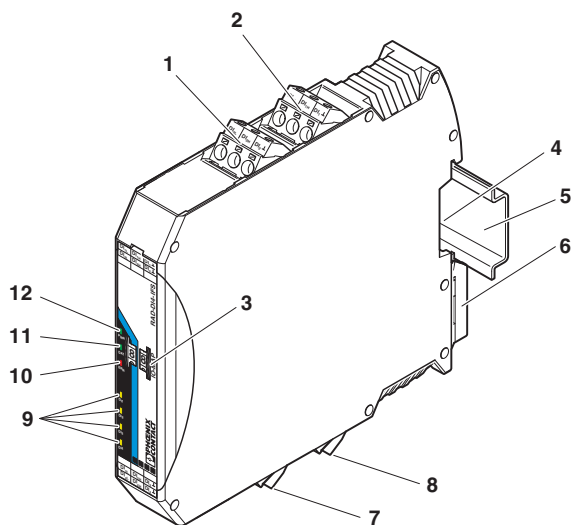

Figure 1 RAD-DI4-IFS

Pos.	Terminal block	Designation
1	2.1 / 2.2 / 2.3	Digital input as wide-range input
2	1.1 / 1.2 / 1.3	Digital input as wide-range input
3		White thumbwheel for setting the I/O-MAP address
4		Connection option for DIN rail connector
5		DIN rail
6		Metal foot catch for DIN rail fixing
7	5.1 / 5.2 / 5.3	Digital input as wide-range input
8	6.1 / 6.2 / 6.3	Digital input as wide-range input
9		Status LEDs for the digital inputs DI1...DI4
10		ERR status LED, red (communication error)
11		DAT status LED, green (BUS communication)
12		PWR status LED, green (supply voltage)

6.2 Basic circuit diagram

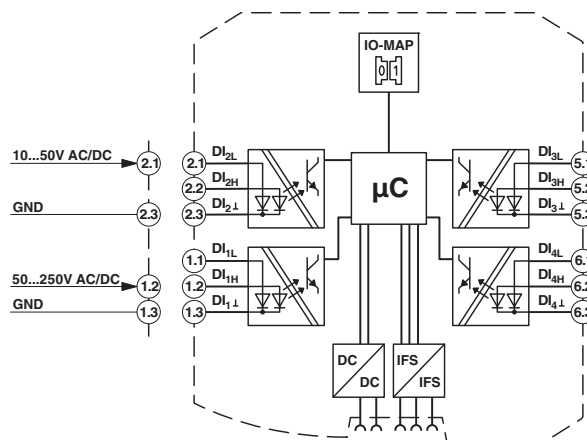

Figure 2 RAD-DI4-IFS basic circuit diagram

6.3 I/O MAP address in the Radioline wireless system

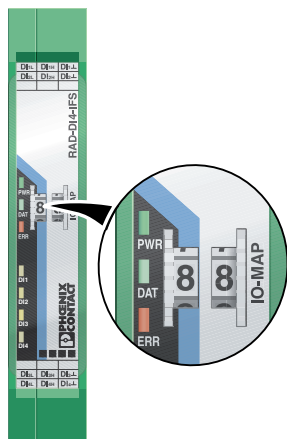

Figure 3 Thumb wheel

Use the thumbwheel to set the I/O-MAP address. The extension module in the Radioline wireless system is addressed using the I/O-MAP address.

On the entire wireless network, addresses 1 to 99 (I/O MAP) (maximum) may be assigned for the I/O extension modules.

Thumbwheel	Description
01 - 99	I/O MAP address
00	Delivery state
** , 1* - 9*	Setting not permitted
*1 - *9	Interface System slave address, for use with other Interface System (IFS) master devices

Wireless module in I/O data mode

The input device must be provided with the same I/O MAP address as the assigned output device at the other wireless station (I/O mapping).

The I/O MAP address of an input module may only appear once in the network.

Example:	I/O MAP address
RAD-DI4-IFS	02
RAD-DOR4-IFS	02

Only the RAD-DOR4-IFS module can be assigned to the RAD-DI4-IFS module.

Wireless module in PLC/Modbus RTU mode

The I/O MAP address of an input module may only appear once in the network.

The input data is saved in a Modbus memory map in the master wireless module. You can read or write the process data via the serial interface of the master wireless module (RAD-ID = 01) using the Modbus RTU commands (see Section 7).

6.4 Display and diagnostic elements

7 LEDs on the RAD-DI4-IFS I/O extension module in total indicate the operating states.

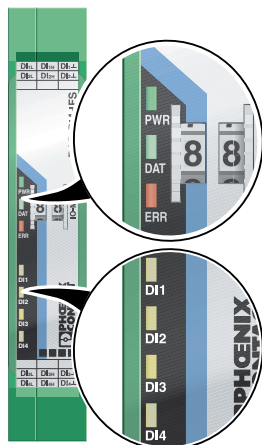

Figure 4 Display and diagnostic elements

PWR LED

The green PWR LED indicates the supply voltage status.

OFF	No supply voltage
ON	Supply voltage OK

DAT LED

The green DAT LED indicates the bus communication status.

OFF	No communication
Flashing	Configuration and addressing mode
ON	Cyclic data communication

ERR LED

The red ERR LED indicates the error status, e.g., no corresponding output module found (e.g., incorrect addressing).

OFF	No error
Flashing	I/O-MAP address changed
	Slow (1.4 Hz)
	Fast (2.8 Hz)
	No bus communication
ON	Critical internal error

DI1 ... DI4

The yellow DI1 ... DI4 LEDs indicate the status of the digital inputs.

6.5 Digital inputs

The digital inputs are electrically isolated (reinforced insulation) from one another, from the supply voltage (via the bus foot), and from other electronic components.

The digital inputs of the device are used to process low voltages in the 0...50 V AC/DC range and high voltages in the 0...250 V AC/DC range.

6.6 Mounting and removing

Connection station with I/O extension modules

Up to 32 different I/O extension modules can be connected to every wireless module via the DIN rail connector (see accessories). Data is transmitted and power is supplied to the I/O extension modules via the bus foot.

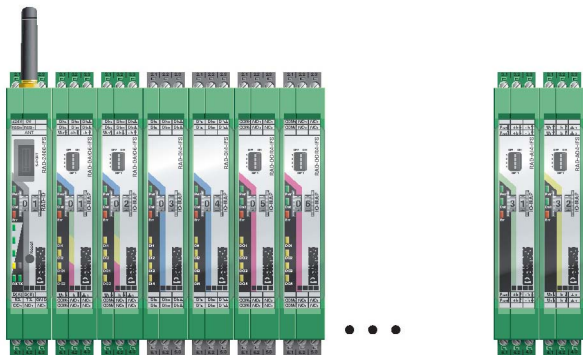

Figure 5 Radioline connection station with up to 32 I/O extension modules



Only mount the I/O extension modules to the right of the wireless module.

Assembly

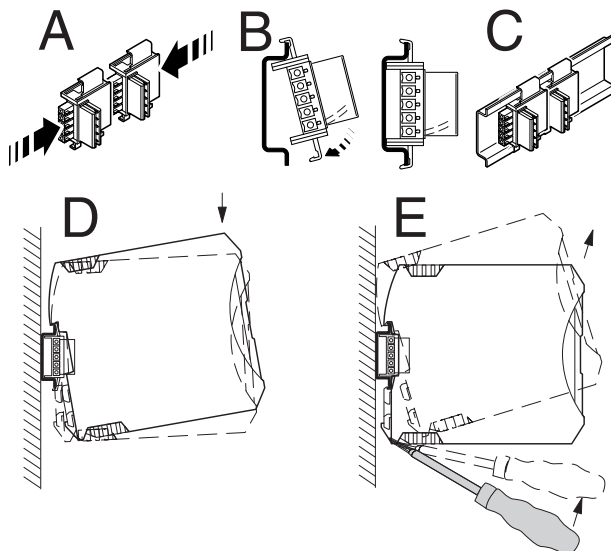

Figure 6 Mounting and removing

When using the device in a connection station, use the 17.5 mm wide DIN rail connector supplied. Only use the DIN rail connector in connection with 24 V DC devices.



Outside the Ex area, module extension or module replacement is also possible during operation.

- Connect the DIN rail connectors together for a connection station.
- Push the connected DIN rail connectors into the DIN rail.
- Place the device onto the DIN rail from above. Ensure the device and DIN rail connector are aligned correctly.
- Holding the device by the housing cover, carefully push the device towards the mounting surface so that the device bus connector is securely fixed onto the DIN rail connector.
- Once the snap-on foot has been audibly snapped onto the DIN rail, check that it is fixed securely. The device is only mechanically secured via the DIN rail.
- Connect the desired number of I/O extension modules to the wireless module via the DIN rail connector.
- In order to meet the requirements for the protection class, install the device in suitable housing.
- During startup, check that the device is operating, wired, and marked correctly.
- You can establish a connection between two DIN rail connectors using MINI COMBICON connectors: MC 1,5/5-ST-3,81 (female, 1803604); IMC 1,5/5-ST-3,81 (male, 1857919).

Removing

- Use a suitable screwdriver to release the locking mechanism on the snap-on foot of the device.
- Hold onto the device by the housing cover and carefully tilt it upwards.
- Carefully lift the device off the DIN rail connector and the DIN rail.



**SCATTERGOOD
& JOHNSON LTD**
ELECTRICAL ENGINEERING & FLUID CONTROL DISTRIBUTORS

Est.1899

At Scattergood & Johnson Ltd, we pride ourselves on being a technical distributor to specialist industries.

Working with a range of quality product suppliers across a number of specialist markets, we are not your average 'box shifter' - we are your technical and supply chain partner.

We fully support every product we sell - for free! Our internal team and external sales engineers can answer any product or application question, no matter the complexity.

Backing up this technical ability is a range of 50,000+ products available from stock for nationwide next day delivery (same day if required!), or you can collect what you need from any of our trade counters around the UK.

Select your specialist interest below to learn more about how we can help.

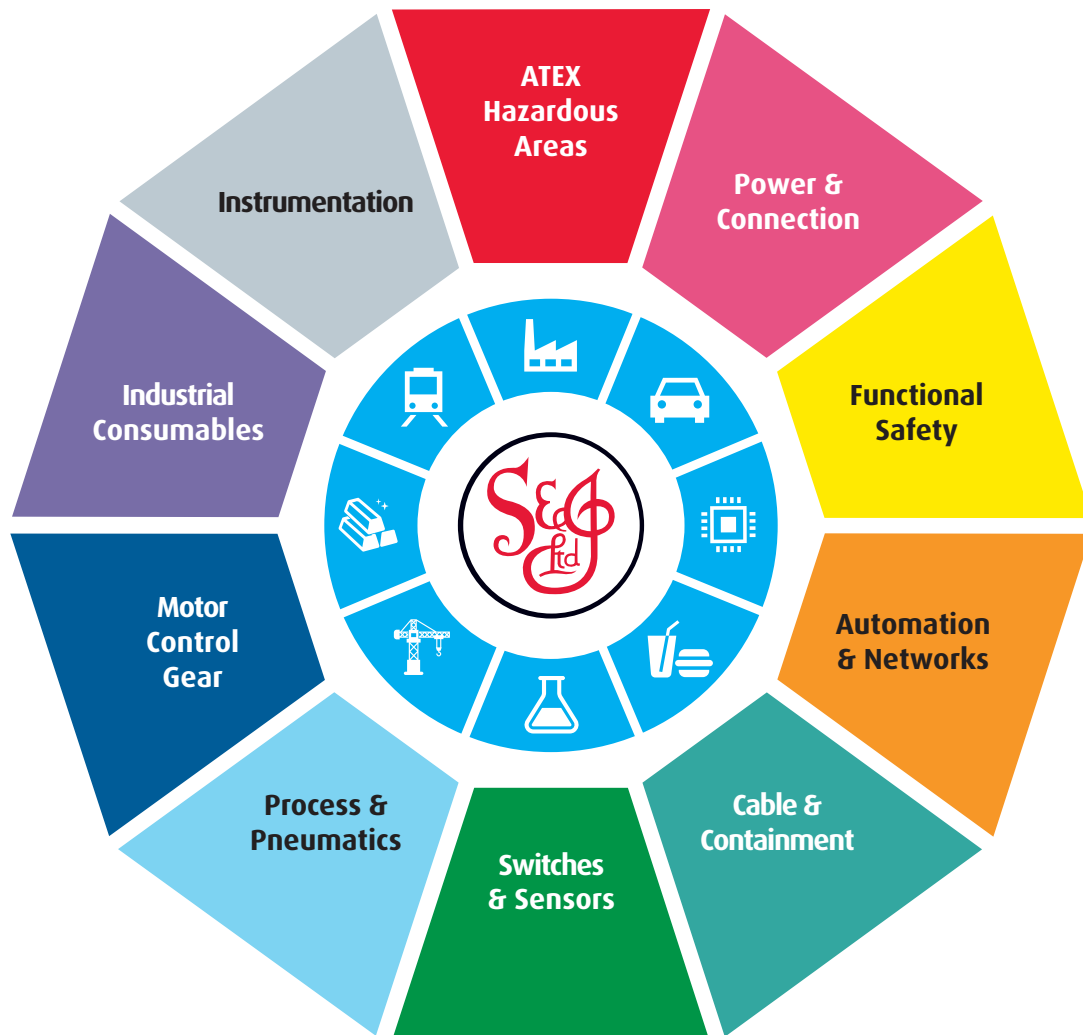

Online, In Branch and On the Road - Scattergood & Johnson Ltd, there when you need us.

www.scatts.co.uk