

RAD-...-IFS

Frequently asked questions (FAQs) about Radioline



Application note 106681_en_01

© PHOENIX CONTACT 2017-07-20

The Radioline system consists of the following front modules:

Description	Frequency	Area of application	Designation	Order No.	Link to item
Wireless module	2.4 GHz	Worldwide	RAD-2400-IFS	2901541	phoenixcontact.net/product/2901541
		Japan	RAD-2400-IFS-JP	2702863	phoenixcontact.net/product/2702863
	868 MHz	Europe	RAD-868-IFS	2904909	phoenixcontact.net/product/2904909
	900 MHz	America	RAD-900-IFS	2901540	phoenixcontact.net/product/2901540
		Australia	RAD-900-IFS-AU	2702878	phoenixcontact.net/product/2702878
RS-485 front module	-	Worldwide	RAD-RS485-IFS	2702184	phoenixcontact.net/product/2702184



This application note does **not** replace the device-specific documents.
Please follow the safety notes in the associated packing slips.



Make sure you always use the latest documentation.
It can be downloaded at phoenixcontact.net/products.

Table of contents

1	Radioline wireless system.....	4
1.1	Which frequency is required to operate the system?	4
1.2	In which countries can I use Radioline devices?.....	4
1.3	Do I have to register the system?	4
1.4	Are there any follow-up costs that may arise for using the system?.....	4
1.5	What is the transmission power of the system?.....	4
1.6	What does “bidirectional” mean?.....	4
1.7	Which wireless technology is used in the Radioline devices?	4
1.8	Is Trusted Wireless really suitable for industrial use?	4
1.9	Why is no standard (Bluetooth, WLAN) used?	5
1.10	What does roaming mean?	5
1.11	Is Trusted Wireless protected against manipulation?	5
1.12	What is the purpose of data encryption?	5
1.13	What does duty cycle mean in the case of 868 MHz devices?	5
1.14	Are radio beams dangerous?	6
1.15	In what way do the 868 MHz and 2.4 GHz wireless systems differ?	6
2	Configuration and startup.....	7
2.1	What are RF bands?	7
2.2	Is operation parallel to a WLAN network possible?.....	8
2.3	Do I need software in order to start up the wireless modules?.....	8
2.4	What is a CONFSTICK used for?	8
2.5	What is a memory stick used for?.....	8
2.6	What is the Net ID used for?.....	8
2.7	Why is the data transmission rate of the wireless interface adjustable?	8
2.8	How are the devices started up?	8
2.9	How does the wireless module “know” if it is a slave or repeater/slave?.....	8
2.10	Which address (RAD ID) must I set on the wireless modules?	9
2.11	How many network devices are possible?.....	9
2.12	Can several wireless modules in a network have the same RAD ID?	9
2.13	Do the wireless modules have to be numbered consecutively (01, 02, 03...)?.....	9
2.14	What is the difference between a repeater, repeater/slave, and slave?.....	9
2.15	Does the use of several repeaters in a network result in longer response times?	10
2.16	How can I/O signals be transmitted or the system extended?	10
2.17	What does hot-swappable mean?	10
2.18	What does I/O mapping mean?	10
2.19	How are the input and output modules assigned in a network?.....	10
2.20	Can I assign several output modules to an input module via I/O mapping?	10
2.21	Why are there yellow and white thumbwheels in the Radioline system?	10
2.22	What happens if I set address “00” at the thumbwheel?	10
2.23	What happens if two input modules or two output modules have the same thumbwheel setting?	10
2.24	How many extension modules can I connect to a station?	10
2.25	What is the maximum number of signals that I can transmit?	11
2.26	Is the DIN rail connector supplied as standard?	11
2.27	What is the SET button on the front of the wireless module used for?	11

2.28	How can I see which wireless modules belong together?.....	11
2.29	Can several stations in the field also be connected to a central station? Is a multipoint-to-point connection possible?.....	11
2.30	How many Radioline systems can I use in close proximity to one another?	11
2.31	How is the Radioline system affected by WLAN and Bluetooth?.....	11
2.32	How does the Radioline system affect Bluetooth?	11
2.33	How does the Radioline system affect WLAN?	11
2.34	Which analog signals can be transmitted?	11
2.35	How can I transmit other analog signals?	12
2.36	What is the Power OUT connection on the analog input modules used for?	12
2.37	Do I need different wireless modules to transmit I/O signals and serial data?	12
2.38	Do I have to use the PSI-CONF software for the serial data transmission (RS-232, RS-485)?.....	12
2.39	Can I transmit Modbus and PROFIBUS?	12
2.40	Can I/O signals and serial data be operated in parallel with the Radioline system?.....	12
2.41	How are firmware updates implemented?	12
2.42	Which operating modes are there?	13
3	Diagnostics	14
3.1	What do the LEDs on the front indicate?	14
3.2	How can I get information about the wireless path (diagnostic options)?	14
3.3	Why does only the yellow LED light up at the master?	15
3.4	Is it possible to send diagnostic information directly to the controller using Radioline?	15
3.5	How do the outputs behave in the event of an error?.....	15
4	Use in the Ex area / Approvals	16
4.1	Which antennas can I use in the Ex area?.....	16
4.2	From which zones can I connect sensors/actuators to the Radioline system?	16
4.3	Are the devices suitable for shipbuilding licenses or offshore wind farms?	16
5	Antenna	16
5.1	What is the name of the antenna connection on the wireless module?.....	16
5.2	What is an omnidirectional antenna (OMNI antenna)?	16
5.3	What are directional antennas (panel, Yagi, parabolic)?	16
5.4	What does antenna gain mean?	16
5.5	What do the apex angles of the antennas indicate?	16
5.6	What is a pigtail?	16
5.7	Can the antenna cable be extended? If so, how long can the cable be?	17
5.8	Where and how should I install the antenna?	17
5.9	What ranges can be reached with the wireless modules?	17
5.10	What is a Fresnel zone?	17
5.11	Does the number of I/O extension modules affect the transmission range?	17
5.12	In which way do different materials affect the range?	17
5.13	What influence do trees and bushes have?	18
5.14	Can I mix antenna types?	18
5.15	How do I select an antenna?	18
5.16	What must the distance be to neighboring antennas?.....	18

1 Radioline wireless system

1.1 Which frequency is required to operate the system?

The Radioline wireless system operates in the following frequency bands depending on the wireless module:

Frequency range	Area of application
2.4002 GHz ... 2.4785 GHz	Worldwide (incl. Japan)
869.4 MHz ... 869.65 MHz	Europe
902 MHz ... 928 MHz	America
915 MHz ... 928 MHz	Australia

1.2 In which countries can I use Radioline devices?

See list of approved countries at phoenixcontact.net/products

1.3 Do I have to register the system?

The frequency bands used belong to the ISM (Industrial, Scientific and Medical) bands. ISM bands are license-free frequency bands for industrial, scientific, and medical applications. For these worldwide usable frequency bands, only the transmission power and interference of neighboring frequency ranges are regulated. For this reason, you do not have to register the system. There are no license fees.

1.4 Are there any follow-up costs that may arise for using the system?

There are no follow-up costs that may arise for using the system.

1.5 What is the transmission power of the system?

The output power at the antenna socket of the transmitter depends on the frequency bands used. You can set the transmission power using the PSI-CONF software.

In total, the radiated power of the antenna (EIRP = Effective Isotropically Radiated Power) must not exceed the maximum permissible value:

- 2.4 GHz:
 - Maximum of 20 dBm outside Europe
 - Maximum of 19 dBm in Europe, depending on the set transmission rate
- 868 MHz:
 - Maximum of 27 dBm
- 900 MHz:
 - Maximum of 30 dBm

Calculation basis for EIRP:

$$EIRP = P_T - D_{TC} + G_{TA}$$

$$P = P_T - D_{TC} + G_{TA} - D_A + G_{RA} - D_{RC}$$

P_T = Transmitter power in dBm

D_{TC} = Losses of the transmitter cable in dB

G_{TA} = Gain of the transmitting antenna in dBi

P = Incoming power for the receiver in dBm

D_A = Attenuation of the air (free space attenuation) in dB

G_{RA} = Gain of the receiving antenna in dBi

D_{RC} = Attenuation of the antenna cable at the receiver in dB

1.6 What does "bidirectional" mean?

The Radioline wireless modules operate bidirectionally. Bidirectional means that information is transferred in both directions, via the forward and return path.

1.7 Which wireless technology is used in the Radioline devices?

A proprietary wireless protocol is used in the Radioline wireless system. The wireless technology is called Trusted Wireless. It is specifically designed for the reliable transmission of data and signals over long distances.

Version 2.0 offers:

- Adjustable data rates
- Encryption
- Extended diagnostics
- Parallel operation of multiple networks

1.8 Is Trusted Wireless really suitable for industrial use?

The frequency hopping spread spectrum enables reliable data transmission even in industrial environments and in the event of interference.

1.9 Why is no standard (Bluetooth, WLAN) used?

Trusted Wireless 2.0 is a wireless technology which has been developed specifically for industrial use. It is particularly suitable for the following applications:

- When cable infrastructure for sensor/actuator information is missing
- Transmission of small or medium data amounts
- Greater distances of several hundred meters to several kilometers

The main features of Trusted Wireless 2.0 are:

- Robust communication thanks to the frequency hopping spread spectrum (FHSS)
- Automatic coexistence mechanisms (frequency hopping spread spectrum method, duty cycle)
- Manual coexistence mechanisms (WLAN blacklisting)
- Secure communication thanks to 128-bit AES data encryption and authentication
- Long range thanks to high receiver sensitivity and variable data transmission rates
- Flexible networks with automatic connection management and up to 250 devices
- Distributed network maintenance speeds up and simplifies the integration of new devices and restructuring if a device fails
- Extensive diagnostic properties
- Can be adapted to the respective application

Neither Bluetooth nor WLAN have been defined and developed for this use.

1.10 What does roaming mean?

The term roaming was first used in the mobile communication sector (GSM). Roaming is the switching between different mobile networks or WLAN networks.

In the Radioline wireless system, the term roaming means that in the event of a wireless connection failing, data communication is still possible by redirecting via other available network nodes. Self-organization and self-healing keep the network stable. Every device can have multiple communication paths.

1.11 Is Trusted Wireless protected against manipulation?

Trusted Wireless 2.0 uses several security mechanisms to prevent unauthorized access to the transmitted data. Firstly, data security is increased by the proprietary protocol itself. The protocol is not disclosed. Its structures are unknown.

In addition, two proven security mechanisms (data encryption and identity verification) have been implemented. Data encryption makes sure that intercepted data packets are not "understood". Depending on the requirements, the user can switch encryption on or off for their Radioline modules.

The authenticity of the transmitter is checked within the scope of identity verification. For this, a continuous code is added to the message, which must not be repeated. An altered message is recognized as being invalid and is rejected. This mechanism protects the wireless path against intercepted or altered messages being fed back in.

An adjustable data repetition rate enables the multiple transmission of data while transmission security is maintained. Moreover, listening in is made even harder due to the use of the frequency hopping spread spectrum (FHSS).

1.12 What is the purpose of data encryption?

You can enable or disable the 128-bit AES (Advanced Encryption Standard) data encryption. Activated encryption increases data security and slows down data communication. Following activation, you must enter a password for encryption. Encryption according to AES makes sure that intercepted data packets are not "understood". The 128-bit long key is calculated from a given password. It must be known to all wireless modules in the network.

1.13 What does duty cycle mean in the case of 868 MHz devices?

The duty cycle or holding period refers to the legally regulated period of use for the 869.4 MHz ... 869.65 MHz frequency band. The aim of this regulation is to ensure the function of all devices operating in this frequency band. The maximum transmission time is 10 % of one hour (6 minutes). The duty cycle is not usually reached during operation, since only low volumes of data are transmitted.

1.14 Are radio beams dangerous?

The 868 MHz wireless system transmits with maximum 500 mW of power, which corresponds to an averaged radiated power of 5 mW. This radiation value is very low compared to the millions of mobile phones used. Mobile phones continuously transmit with 2000 mW of power. They are mostly used directly next to the head without any further protection. This means approx. 100 mW are absorbed by the head during the entire phone call.

The 868 MHz wireless system is generally operated as a radio link and not directly next to the body. If the body is only one meter away, the radiated power is reduced by factor 40. At the very worst, a radiated power of just 0.125 mW would reach the head when in the immediate vicinity of the antenna. The radiated power is 800 times lower than that of a mobile phone.

In addition, radiated power is only emitted during transmission. Therefore due to the 10% duty cycle, this only occurs for a very short time. For this reason, the electromagnetic fields have no effect on the human body.

1.15 In what way do the 868 MHz and 2.4 GHz wireless systems differ?

Advantages of 868 MHz and 900 MHz

- Higher transmission power
- Significantly longer distances
- If radio waves are transmitted through walls or other obstacles, this weakens the signal. The higher the frequency, the greater the attenuation. The attenuation for a 2.4 GHz signal is greater than that for a 868 MHz or a 900 MHz signal.
- 2.4 GHz radio waves decay faster than 868 MHz or 900 MHz waves if they are reflected by thick surfaces. In densely built-up environments, the signal quality can therefore deteriorate quickly for 2.4 GHz transmission.

Advantages of 2.4 GHz

- Smaller antennas (due to lower wavelength)
- Faster transmission time
- Higher data throughput
- Dozens of parallel networks possible because of the wider frequency band

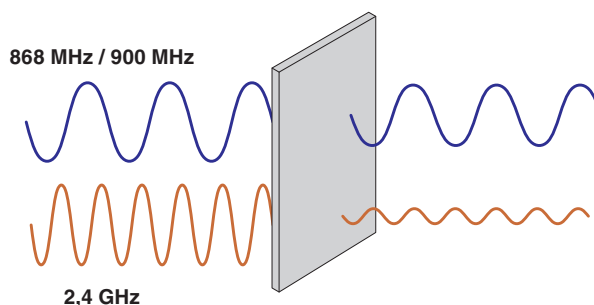

Figure 1 Penetration of obstacles at different frequencies

Technical data	2.4002 GHz ... 2.4785 GHz	869.4 MHz ... 869.65 MHz	902 MHz ... 928 MHz
Number of usable channels	55	14	8
Number of network devices	249	98	249
Base load of frequency band	High	Low	Medium
Risk of data collision	Low	Very low	Low
Coexistence features	Very good	Good	Good
Duty cycle	100%	10%	100%
Data rate [kbps]	16 ... 250	1.2 ... 120	15 ... 500
Transmission power [dBm]	20 (Europe 19)	27	30
Range [km] ¹	≤ 5	≤ 20	≤ 32
Material penetration	Low	High	High

¹ The range is dependent upon the set data rate, use of gain antennas, unobstructed line of sight, observing the Fresnel zone

2 Configuration and startup

2.1 What are RF bands?

In order to optimize the parallel operation of several wireless networks, there is a choice of frequency bands (RF bands). An RF band is a group of frequencies made up of individual frequencies from the entire band. Different RF bands use different frequencies. If you operate several wireless networks in close proximity to one another, you must select different RF bands. There are two options for configuring a different RF band:

CONFSTICK

Using a CONFSTICK, you can activate another RF band quickly and easily without any programming effort.

PSI-CONF software

RF bands can be selected using this software. With the 2.4 GHz devices, WLAN channels can also be hidden (blacklisting) so that Radioline wireless systems can be operated parallel to WLAN systems.

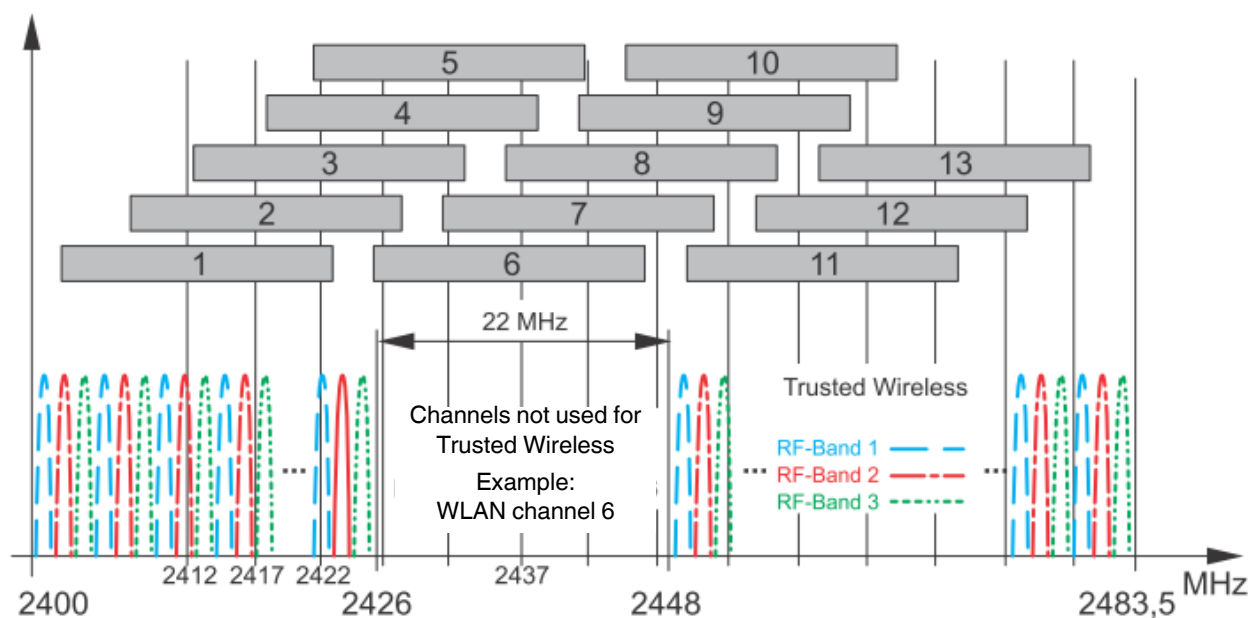

Figure 2 RF bands in the 2.4 MHz wireless system

2.2 Is operation parallel to a WLAN network possible?

The Trusted Wireless technology uses the frequency hopping spread spectrum (FHSS). For this reason, you can operate Radioline wireless systems trouble-free parallel to other systems like WLAN and Bluetooth. In addition, the WLAN channels can be hidden manually using the PSI-CONF software.

2.3 Do I need software in order to start up the wireless modules?

No, the wireless modules have a default configuration. The master, repeater or slave function can be assigned using the thumbwheel (RAD ID) on the front. The PSI-CONF software is available for extended configuration settings.

2.4 What is a CONFSTICK used for?

The CONFSTICK is a portable mass storage device. It is used to configure a unique wireless network via the S-PORT of the wireless module.

Each CONFSTICK also contains a unique network ID (Net ID), which is used for identifying the wireless modules in the network. This Net ID **cannot** be assigned using the PSI-CONF software.

2.5 What is a memory stick used for?

Your individual configuration data can be saved to a memory stick (RAD MEMORY), e.g., to transfer the same configuration to other devices. Using the memory stick, you can, for example, easily integrate new network devices into an existing wireless network without any programming effort.

The memory stick contains the following parameters:

Common network parameters

- Operating mode
- Network-ID (1 ... 127, no IDs via CONFSTICK)
- RF band
- Data rate of the wireless interface
- Encryption
- Network type

Individual device parameters

- Station name
- RAD ID
- Transmission power
- List of permitted connections
- Receive preamplifier ON/OFF
- Serial interface parameters

2.6 What is the Net ID used for?

The network ID (Net ID) is a network parameter used to identify the wireless modules. Only wireless modules with the same Net ID can establish a connection to each other.

Value range which you can set using the PSI-CONF software: 1 ... 127

A globally unique network ID can be assigned using a CONFSTICK. The CONFSTICK can be ordered separately.

2.7 Why is the data transmission rate of the wireless interface adjustable?

Adjusting the data transmission rate of the wireless interface changes the receiver sensitivity of the wireless module. You can cover much longer distances with a low data rate than with a high data rate.

2.8 How are the devices started up?

- For simple I/O-to-I/O applications (wire in/wire out), addressing is carried out easily using the thumbwheel (RAD ID). In this way, you can establish a wireless connection to other RAD-...-IFS devices without any programming effort. Each address in a network must be unique.
- For serial data transmission via the wireless interface or changes to the default settings, the wireless modules must be configured using the PSI-CONF software. Afterwards, you must transfer the data to every wireless module.
- Your individual configuration data can be saved to a memory stick (RAD MEMORY), e.g., to transfer the same configuration to other devices. Using the memory stick, you can, for example, easily integrate new network devices into an existing wireless network without any programming effort.

2.9 How does the wireless module “know” if it is a slave or repeater/slave?

The wireless module is a master, slave or repeater/slave based on the thumbwheel setting (see following question).

You can also assign the addresses and roles via the PSI-CONF software. In this case, set the thumbwheel to **.

2.10 Which address (RAD ID) must I set on the wireless modules?

Addressing using the thumbwheel depends on the desired network structure:

Mesh / Line / Point-to-point

- 01 Master address
- 02 ... 99 Repeater/slave addresses

Star / Point-to-point (speed optimized)

- *1 Master address
- *2 ... *9 Slave addresses

Please note:

- Mixed operation (e.g., "01", "02", "*3") is not possible.
- Each address may only be assigned once in a network.

2.11 How many network devices are possible?

The maximum number of devices depends on the network structure and the frequency band:

Mesh / Line

- Addressing using the thumbwheel (no software required)
- One master and up to 98 repeaters/slaves in a network

Star

- Addressing using the thumbwheel (no software required)
- One master and up to 8 slaves in a network
- RAD ID: *2 ... *9

Mesh / Line / Star

- Addressing using the PSI-CONF software
- 2.4 GHz and 900 MHz: One master and up to 249 repeaters/slaves or slaves
- 868 MHz: One master and up to 98 repeaters/slaves or slaves

2.12 Can several wireless modules in a network have the same RAD ID?

Every wireless module in a network must have a different address. Each RAD ID in a network is unique. Duplicate addresses are not permitted in a network and result in errors.

2.13 Do the wireless modules have to be numbered consecutively (01, 02, 03...)?

No, you can set any address between 01 and 99 using the thumbwheel. In addition, addresses 100 ... 250 can be set using the PSI-CONF software.

Please note:

- The address 01 is reserved for the wireless master.
- Mixed operation (e.g., "01", "02", "*3") is not possible.
- Each address may only be assigned once in a network.

2.14 What is the difference between a repeater, repeater/slave, and slave?

Repeaters

A repeater wireless module can receive and forward data. A repeater is for signal amplification. The ranges in the network are increased.

Repeater/slave

A repeater/slave wireless module (network nodes) fulfills two functions. On the one hand, the wireless module acts as repeater by receiving and forwarding or amplifying data. On the other hand, the wireless module acts as a slave by recording data from I/O extension modules or serial I/O devices. When a wireless module is configured as a repeater/slave, it uses the store-and-forward function for data transmission in networks with more than one wireless module.

Slave

I/O extension modules or serial I/O devices can be connected to a slave wireless module. Unlike a master, a slave only has subordinate rights.

2.15 Does the use of several repeaters in a network result in longer response times?

The response time of the network will increase by using repeaters/slaves.

2.16 How can I/O signals be transmitted or the system extended?

You can extend the Radioline wireless system with I/O extension modules. Various analog and digital input and output modules are available.

The extension modules are connected to the wireless module via the TBUS connector on the module base. The extension module is supplied and communication is established via this connection. The devices are hot-swappable.

2.17 What does hot-swappable mean?

Hot-swappable devices can be connected or exchanged during operation. A voltage reset is not required.

2.18 What does I/O mapping mean?

I/O mapping simplifies signal distribution in your system. Assign inputs and outputs quickly by simply turning the thumbwheel. In this way you can distribute and multiply I/O signals freely in your network – without the need for any complex programming.

2.19 How are the input and output modules assigned in a network?

In order to enable the transmission of signals, you must provide and assign a corresponding output module to an input module. This is done using the thumbwheel with the corresponding I/O MAP addresses of 0 to 99. The input module must have the same I/O MAP address as the assigned output module at the other end of the transmission system.

Example: a digital input module is set to I/O MAP address 12 and the assigned digital output module is also set to I/O MAP address 12.

You can connect the desired number of I/O extension modules to the wireless module via the DIN rail connector. Then press the SET button on the wireless module to read the current station configuration. Alternatively, the settings are also applied when the station is powered up.

2.20 Can I assign several output modules to an input module via I/O mapping?

Each I/O MAP address may only be used on one input module. You can assign one or more output modules to this input module. To do this, set the same I/O MAP address on the output module as on the input module.

2.21 Why are there yellow and white thumbwheels in the Radioline system?

Yellow: wireless module

Use the yellow thumbwheel (RAD ID) to address the wireless modules in the network. This address must be unique for each wireless module.

White: extension module

Use the white thumbwheel to address the I/O extension modules. The input module must have the same I/O MAP address as the assigned output module at the other end of the transmission system. This is how the input and output signals are assigned in the network.

2.22 What happens if I set address "00" at the thumbwheel?

Address "00" must not be set for the wireless modules (yellow thumbwheel). This generates an error message. Addresses 01 ... 99 (mesh network) or *1 ... *9 (star network) are available for addressing the wireless modules.

Address 00 is set by default for the I/O extension modules (white thumbwheel). If two I/O extension modules are set to this address, an error is generated. Addresses 01 ... 99 are available for addressing the input and output modules.

2.23 What happens if two input modules or two output modules have the same thumbwheel setting?

Each I/O MAP address may only be used on one input module. You can assign one or more output modules to this input module. To do this, set the same I/O MAP address on the output module as on the input module.

2.24 How many extension modules can I connect to a station?

You can connect a maximum of 32 I/O extension modules to the wireless module via the bus foot.

2.25 What is the maximum number of signals that I can transmit?

Point-to-point connection

- RAD-DI4-IFS / RAD-DOR4-IFS: maximum of 128 digital signals
- RAD-DI8-IFS / RAD-DO8-IFS: maximum of 256 digital signals
- RAD-AI4-IFS / RAD-AO4-IFS: maximum of 128 analog signals
- RAD-DAIO6-IFS: maximum of 64 digital and 32 analog signals

2.26 Is the DIN rail connector supplied as standard?

Yes, a DIN rail connector is supplied with every module.

2.27 What is the SET button on the front of the wireless module used for?

The SET button is used to confirm a station change, without having to perform a power up. After making any change, press the SET button for one second to apply the settings. The DAT LED starts flashing. Read in has been completed when the DAT LED is permanently on.

Station changes include:

- RAD ID address of the wireless module changed
- I/O MAP address of the extension modules changed
- I/O extension module added
- I/O extension module removed
- Memory stick used
- CONFSTICK used

2.28 How can I see which wireless modules belong together?

All wireless modules are configured in the same way by default. Assign the address using the yellow thumbwheel (RAD ID). In this way, you assign the devices to one another.

2.29 Can several stations in the field also be connected to a central station? Is a multipoint-to-point connection possible?

Yes, you can create mesh or star networks.

- 2.4 GHz and 900 MHz: One master and up to 249 repeaters/slaves or slaves
- 868 MHz: One master and up to 98 repeaters/slaves or slaves

2.30 How many Radioline systems can I use in close proximity to one another?

2.4 GHz

If you operate the system in an environment with more than one network in the 2.4 GHz band or other networks (e.g., WLAN or Bluetooth), you have two options:

- Use the CONFSTICK configuration memory with different RF bands
- Configure advanced settings using the PSI-CONF software (e.g., hide WLAN channels)

You can create dozens of parallel networks in close proximity by using different RF bands and Net IDs.

868 MHz

You can only operate a few networks in parallel because of the narrower frequency bands.

2.31 How is the Radioline system affected by WLAN and Bluetooth?

Because of the frequency hopping spread spectrum, WLAN and Bluetooth may, at the most, slow down the system, but they will not make it crash. This would require a massive disturbance to the entire frequency band. In addition, you can hide WLAN channels using the PSI-CONF software (WLAN blacklist).

2.32 How does the Radioline system affect Bluetooth?

The Radioline system does not affect the Bluetooth system as Bluetooth tolerates errors.

2.33 How does the Radioline system affect WLAN?

The Radioline system can disrupt the WLAN network if the devices and antennas are operated directly next to one another. In this case, you can hide WLAN channels (WLAN blacklist) and set the transmission power using the software. The hidden frequency range of the WLAN channel will not be used for wireless communication. This enables interference-free parallel operation.

2.34 Which analog signals can be transmitted?

You can connect signals with 0 mA ... 20 mA and 4 mA ... 20 mA (open circuit monitoring) to the analog input modules. In addition there is a Pt 100 input module. Signals with 0 mA ... 20 mA / 4 mA ... 20 mA and 0 V ... 10 V are output via the corresponding analog output modules.

2.35 How can I transmit other analog signals?

Phoenix Contact offers MCR signal converters in its product range for converting analog signals to a signal with (0)4 mA ... 20 mA.

2.36 What is the Power OUT connection on the analog input modules used for?

A supply voltage of at least 12 V is provided via the PWR terminal. In this way you can connect and supply passive sensors.

Is extended software configuration only possible via the master or do I have to transfer this configuration individually to each wireless module?

There are three options for transferring the configuration to devices using the PSI-CONF software:

- Via cable for all connected devices
- Wirelessly via the master (to all devices in the network)
- Individually configured RAD MEMORY stick

2.37 Do I need different wireless modules to transmit I/O signals and serial data?

No, you can use the wireless module to transmit serial data (RS-232 and RS-485) and I/O signals via extension modules.

2.38 Do I have to use the PSI-CONF software for the serial data transmission (RS-232, RS-485)?

Yes, you need the PSI-CONF software for serial data transmission. You need to adapt the devices to the relevant requirements:

- Interface parameters
- Data rate
- RS-232 or RS-485 interface
- Further parameters

2.39 Can I transmit Modbus and PROFIBUS?

Yes, you can transmit protocols such as Modbus or PROFIBUS wirelessly. You have to adapt the serial interface parameters to the relevant application using the PSI-CONF software. You can find further information in the application note "PROFIBUS connections with Radioline wireless modules" at phoenixcontact.net/product/2901541).

2.40 Can I/O signals and serial data be operated in parallel with the Radioline system?

At present, you can choose between three operating modes; parallel operation is not possible.

PLC/Modbus RTU dual mode will be available from firmware 1.80. Dual modes offers you these functions concurrently:

- Transparent transmission of the Modbus protocol
- Access to the I/O data of the Radioline stations via Modbus.

The various operating modes are described on the following page.

2.41 How are firmware updates implemented?

You can update the firmware of the front modules using the PSI-CONF software. For the latest firmware version, please visit the product page at phoenixcontact.net/products.

2.42 Which operating modes are there?

I/O data mode (wire in/wire out)



Figure 3 I/O data mode

By default upon delivery, all wireless modules are in I/O data mode. For simple I/O-to-I/O applications with Radioline extension modules, you can easily set all the addresses using the thumbwheel. In this way, you can establish a wireless connection to other wireless modules and replace I/O signal lines without any programming effort.

The RS-485 interface is only active at the master. You can connect RS-485 front modules (RAD-RS485-IFS) to the interface.

Serial data mode

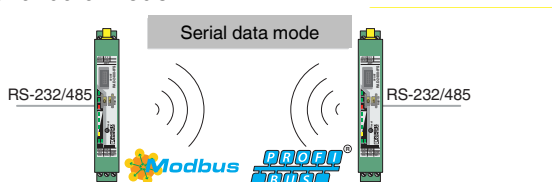

Figure 4 Serial data mode

In serial data mode, multiple controllers or serial I/O devices are networked quickly and easily using wireless technology. In this way, serial RS-232 or RS-485 cables can be replaced.

PLC/Modbus RTU mode

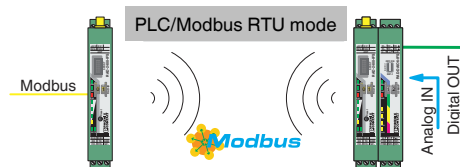

Figure 5 PLC/Modbus RTU mode

In PLC/Modbus RTU mode, the entire wireless network acts like a single Modbus slave. The master wireless module (RAD ID = 01) has its own Modbus address. You can connect I/O extension modules to each wireless module in the network. All I/O data of the extension modules is stored centrally in the internal Modbus memory map of the master wireless module. In addition, the diagnostic data from all wireless devices is stored here. You can connect the extension modules to the controller directly via the integrated RS-232 and RS-485 interface by means of wireless communication.

PLC/Modbus RTU dual mode (from firmware 1.80)

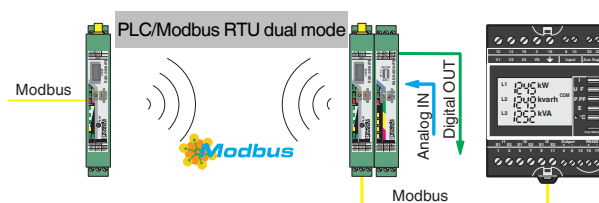

Figure 6 Dual mode

Dual mode joins the PLC/Modbus RTU mode and the serial data mode. You can connect Radioline extension modules to the controller directly via the integrated RS-232 and RS-485 interface by means of wireless communication. You can also connect additional Modbus/RTU slaves in parallel. In dual mode, each station in the wireless network acts as an independent Modbus slave. The yellow RAD ID corresponds to the Modbus address. The Modbus address of the master wireless module (RAD ID = 01) can be changed in order to integrate the wireless system into an existing Modbus network with Modbus address 01.

You can connect I/O extension modules to each station in the network. All I/O data from the extension modules is stored locally in the Modbus memory map of the respective station. Concurrently, you can connect additional Modbus slaves to each wireless station via RS-232 or RS-485, and control them via the respective Modbus address. All diagnostic data of the wireless network can be read out from the wireless master (RAD ID = 01) of the wireless network via Modbus/RTU.

3 Diagnostics

3.1 What do the LEDs on the front indicate?

The LEDs on the front serve as diagnostics and status indicators.

PWR LED

The green PWR LED indicates the status of the supply voltage.

Off	No supply voltage
On	Supply voltage OK

DAT LED

The green DAT LED indicates the status of the IFS bus communication.

Off	No communication
Flashing	Configuration mode
On	Cyclic data communication

ERR LED

The red ERR LED indicates the error status, e.g., no corresponding output module found (e.g., incorrect addressing).

Off	No error	
Flashing	Slow (1.4 Hz)	Wireless module in I/O data mode (wire in/wire out) <ul style="list-style-type: none"> – Double assignment of I/O MAP address – Missing input module – Missing output module – RAD ID changed Wireless module in PLC/Modbus RTU mode <ul style="list-style-type: none"> – Double assignment of I/O MAP address – RAD ID changed – No Modbus communication
	Fast (2.8 kHz)	Wireless connection interrupted
On		Local bus error

3.2 How can I get information about the wireless path (diagnostic options)?

There are basically four options for getting information about the wireless path:

LED bar graph

LEDs	Input signal	RSSI (in V)
All 4 LEDs light up	Connection with maximum receive signal	2.5 V ... 3 V
Yellow LED and 2 green LEDs light up	Connection with very good receive signal	2 V ... 2.5 V
Yellow LED and 1 green LED light up	Connection with good receive signal	1.5 V ... 2 V
Yellow LED lights up	Connection with low receive signal	1 V ... 1.5 V
All LEDs are off	Not connected	0 V

LED bar graph, running light

The running light from bottom to top indicates a firmware update, or that the wireless module is in write mode for the memory stick.

LED bar graph, flashing

The devices are too close to each other.

As the full transmission power and the receive amplifier are activated by default, signals may overlap. Increase the distance between devices.

RF link relay

The RF link relay in the wireless module diagnoses the state of the wireless connection. The relay picks up when the wireless connection is established.

If the device does not receive a data packet correctly over a certain period (depending on the set data rate), the relay drops out. The relay picks up again automatically when the wireless connection is re-established. The relay has been designed as a changeover contact.

RSSI test socket

When a wireless connection is established, you can measure a DC voltage value (0 V ... 3 V) at the socket. The quality of the wireless path can be assessed using this value.

PSI-CONF software

This user-friendly software supports the comprehensive diagnostics of all network devices via the master and the setting of advanced network parameters:

- Network structure setup
- Signal quality of each network station (RSSI)
- Status indicator for the process data of I/O extension modules at each network station
- Recording of RSSI signal and I/O status of each network station

3.3 Why does only the yellow LED light up at the master?

The signal strength in the master direction is displayed at the repeaters/slaves. The signal strength always relates to the directly connected, overlapping wireless module.

If several repeaters/slaves are connected to a master, the master must theoretically indicate the signal strength for several wireless modules. This is not technically possible, however. This is why only the yellow bar graph LED lights up for the master.

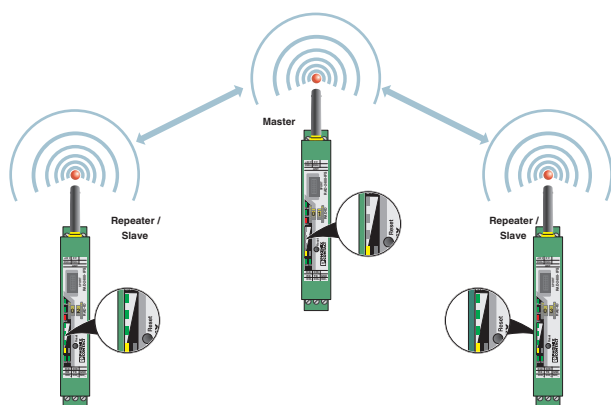

Figure 7 Bar graph for point-to-multipoint connection

3.4 Is it possible to send diagnostic information directly to the controller using Radioline?

You can forward the diagnostic information to a controller via the RF link relay or the RSSI output. Furthermore, you can read the RSSI register via a Modbus/RTU controller in PLC/Modbus RTU mode.

3.5 How do the outputs behave in the event of an error?

You can use DIP switches on the I/O extension modules to set how the analog and digital outputs should behave in the event of interrupted wireless connection.

"HOLD" DIP switch

If the wireless connection is interrupted, the outputs of the I/O extension modules retain their last value or state.

"Reset" DIP switch

If the wireless connection is interrupted, the outputs of the I/O extension modules are reset (output value is set to 0).

4 Use in the Ex area / Approvals



For the latest approvals, please visit the product page at phoenixcontact.net/products.

Please follow the special installation instructions on the packing slip.

4.1 Which antennas can I use in the Ex area?

Only for front modules with ATEX approval:

You can use **selected antennas** from Phoenix Contact in the Ex area. The connection is established via antenna barriers with separate approval as intrinsically safe equipment. Suitable antennas and barriers with ATEX and IECEx approval can be found online under Accessories. Antennas that are connected via the antenna barrier can be installed in Zone 0, 1 or 2.

4.2 From which zones can I connect sensors/actuators to the Radioline system?

Only for front modules with ATEX or UL-HazLoc approval:

You can connect sensors directly to the front module from the non-Ex area and Zone 2 (Div. 2/Class 1). For intrinsically safe sensors from Zone 1 and Zone 0 (Div. 1/Class 1), you must use the corresponding upstream protective circuits (signal conditioners). The inputs are **not** intrinsically safe.

4.3 Are the devices suitable for shipbuilding licenses or offshore wind farms?

No, not at present.

5 Antenna

5.1 What is the name of the antenna connection on the wireless module?

RSMA (female)

5.2 What is an omnidirectional antenna (OMNI antenna)?

An omnidirectional antenna in its simplest form is a dipole that has an emission angle of 360° in the horizontal direction when mounted vertically. These antennas are also known as omni antennas.

5.3 What are directional antennas (panel, Yagi, parabolic)?

Due to their mechanical design, directional antennas can only receive from certain directions and transmit in certain directions.

5.4 What does antenna gain mean?

The gain (amplification) of an antenna is an increase in the sensitivity or transmission power by focusing on certain areas, similar to a lens. No additional energy is supplied for this, instead the existing energy is bundled due to the mechanical design of the antenna and is then “amplified” in preferred directions.

5.5 What do the apex angles of the antennas indicate?

The apex angle describes the emission characteristics of an antenna. The smaller the apex angle, the higher the gain.

5.6 What is a pigtail?

A pigtail is an adapter cable used for jumpering between different HF connectors (e.g., from RSMA connectors to N connectors).

5.7 Can the antenna cable be extended? If so, how long can the cable be?

Phoenix Contact offers the following extensions for the antenna cables:

- 3 m
- 5 m
- 10 m
- 15 m

However, the attenuation of the cables must be taken into consideration when using extension cables. In general, antenna cables should always be kept as short as possible.

5.8 Where and how should I install the antenna?

Install the antenna in such a way that a clear line of sight is possible and there is no shadowing due to obstacles. If OMNI antennas are mounted on walls or masts, the distances must be $\lambda/4$ (a quarter of the wavelength). Otherwise, the emission characteristics of the antenna are strongly influenced.

5.9 What ranges can be reached with the wireless modules?

When the conditions are optimal you can achieve the following ranges:

- 2.4 GHz: ≤ 5 km
- 868 MHz: ≤ 20 km
- 900 MHz: ≤ 32 km

Please note, however, that the range depends on the following factors:

- Transmission power
- Set data rate of the wireless interface
- Length of the antenna cable
- Antenna used
- Line of sight
- Adherence to the Fresnel zone

5.10 What is a Fresnel zone?

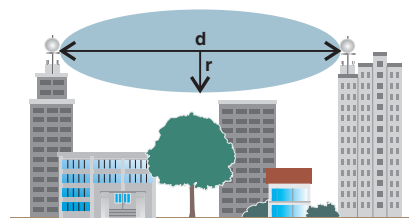

Figure 8 Fresnel zone

For an optimum wireless connection it is not just a line of sight that is required, it must also be possible to provide the Fresnel zone. To achieve good transmission, this zone should be free of obstacles.

5.11 Does the number of I/O extension modules affect the transmission range?

No, the range is not dependent on the number of signals or quantity of data to be transmitted.

5.12 In which way do different materials affect the range?

The table below shows a small selection of materials. These values only serve as guidelines. They are not suitable for calculations:

Obstacle	Typical attenuation in dB	
	2.4 GHz	868 MHz / 900 MHz
Wood, plaster, glass, plastic, uncoated, without metal	3 ... 4	1 ... 2
Brick, chip board	3 ... 5	1 ... 3
Brick wall, 16 cm	6 ... 8	2 ... 4
Concrete wall, 16 cm	15 ... 20	9 ... 11
Reinforced concrete wall, 16 cm	20 ... 30	11 ... 20
Forest, 1 m	9 ... 14	4 ... 8
Heat-absorbing glass with metal coating	40 ... 50	30 ... 40

5.13 What influence do trees and bushes have?

Trees and bushes strongly attenuate the transmission. This influence can almost be disregarded in winter, when there are no leaves on the trees. However in spring, transmission may be made impossible by foliage in the 2.4 GHz band. This must be taken into serious consideration during installation.

In applications with obstacles, use 868 MHz or 900 MHz wireless modules. Lower frequencies can overcome obstacles more easily.

5.14 Can I mix antenna types?

Select the antenna based on local conditions. You can mix different antenna types. If you expect reflections on one end, you can use an omnidirectional antenna. You do not necessarily have to install an omnidirectional antenna on the other end as well. For example, it might be useful to install a directional antenna here, since the signals are coming from a specific direction.

Circular polarized antennas are the exception here. In this case, a circular polarized antenna must be used on both ends.

5.15 How do I select an antenna?

The most suitable antenna depends on the installation location and distance. However, there are no general rules for this.

Omnidirectional antenna

(e.g. RAD-ISM-2400-ANT-OMNI-2-1-RSMA)

- For shorter distances of approx. 100 m ... 300 m
- For installations where reflections can be expected (e.g., in production halls or towns).

Directional antenna

- For longer distances with direct alignment
- When there is strong attenuation from obstacles such as walls or trees

5.16 What must the distance be to neighboring antennas?

If you use several wireless modules at the same location, you must ensure sufficient distances between the antennas.

Frequency	Distance between the antennas (vertical and horizontal)
2.4 GHz	1.5 m ... 2.5 m
868 / 900 MHz	0.5 m ... 1.0 m
5 GHz ¹	0.5 m ... 0.8 m

¹ Not possible with Radioline wireless modules



SCATTERGOOD & JOHNSON LTD

ELECTRICAL ENGINEERING & FLUID CONTROL DISTRIBUTORS

Est.1899

At Scattergood & Johnson Ltd, we pride ourselves on being a technical distributor to specialist industries.

Working with a range of quality product suppliers across a number of specialist markets, we are not your average 'box shifter' - we are your technical and supply chain partner.

We fully support every product we sell - for free! Our internal team and external sales engineers can answer any product or application question, no matter the complexity.

Backing up this technical ability is a range of 50,000+ products available from stock for nationwide next day delivery (same day if required!), or you can collect what you need from any of our trade counters around the UK.

Select your specialist interest below to learn more about how we can help.



Online, In Branch and On the Road - Scattergood & Johnson Ltd, there when you need us.

www.scatts.co.uk