

# RAD-2400-IFS

**2400 MHz wireless transceiver (transmitter and receiver) with RS-232 and RS-485 interface, can be extended with I/O extension modules**

Data sheet  
104835\_en\_10

© PHOENIX CONTACT 2019-06-11



TRUSTED  
WIRELESS™



## 1 Description

In addition to an RS-232 and RS-485 2-wire interface, the **RAD-2400-IFS** wireless module supports the option of directly connecting up to 32 I/O extension modules in the station structure via the DIN rail connector.

Wireless communication is based on Trusted Wireless 2.0 technology. The FHSS (frequency-hopping spread spectrum) method and 128-bit data encryption ensure that the high requirements for interference-free data transmission are met. The wireless modules use the license-free 2.4 GHz ISM band.

Addressing of the wireless module and I/O mapping of the I/O extension modules is carried out quickly and easily by means of the thumbwheel on the front. Programming knowledge is not required.

The wireless network can be extended by up to 98 RS-485 stations. As such, I/O data can be distributed across various media using the thumbwheel.

The PSI-CONF configuration and diagnostics software for special functionality and diagnostic options in the wireless module is available free of charge.

### Features

- Flexible network applications: I/O data, serial data, PLC / Modbus/RTU mode, dual mode
- Adjustable data rates for the wireless interface
- Easy point-to-point or network structures (star, mesh)
- Addressing using the thumbwheel on the front, quick and easy startup
- Integrated RS-232 and RS-485 interface
- Can be extended with up to 32 I/O modules per station via DIN rail connector (hot-swappable)
- 128-bit data encryption (AES)
- Unique network addressing via plug-in configuration memory (RAD-CONF) for secure, parallel operation of multiple networks (different RF bands)
- Data rates and ranges can be adjusted
- International approvals
- Installation in Ex zone 2
- Can be combined with RS-485 stations



#### **WARNING: Explosion hazard when used in potentially explosive areas**

The device is a category 3 item of electrical equipment. Follow the instructions provided here during installation and observe the safety notes.



Make sure you always use the latest documentation.

It can be downloaded at: [phoenixcontact.net/product/2901541](https://phoenixcontact.net/product/2901541)

You will also find the current country approvals at this address.

<b>2</b>	<b>Table of contents</b>	
1	Description .....	1
2	Table of contents .....	2
3	Ordering data .....	3
4	Technical data .....	6
5	Safety regulations and installation notes.....	11
	5.1 Intended use .....	11
	5.2 Installation notes .....	11
	5.3 Installation in Zone 2.....	12
	5.4 UL notes.....	13
	5.5 Approvals and conformity .....	13
6	Installation .....	16
	6.1 Product description .....	16
	6.2 Basic circuit diagram .....	16
	6.3 Display and diagnostic elements .....	17
	6.4 Mounting and removing.....	20
	6.5 Connecting cables .....	21
	6.6 Serial pin assignment .....	21
7	Startup and configuration.....	23
	7.1 Resetting to the default settings.....	23
	7.2 Setting the station address (RAD-ID) .....	23
	7.3 Transmission power .....	24
	7.4 Data transmission speed of the wireless interface .....	24
	7.5 Operating modes .....	24
	7.6 PSI-CONF configuration and diagnostics software .....	25
	7.7 Behavior of the input and output modules in the event of an interrupted wireless connection .....	25
	7.8 Saving the wireless network .....	25
	7.9 Copying device settings to new network devices .....	26
8	Application examples .....	27
9	Process data.....	28

### 3 Ordering data

Description	Type	Order No.	Pcs./Pkt.
Radioline - 2.4 GHz wireless transceiver with RS-232/RS-485 interface, can be extended with I/O modules, RSMA (female) antenna connection, point-to-point, star, and mesh networks up to 250 stations, range of up to 5 km (with a clear line of sight), for worldwide use	RAD-2400-IFS	2901541	1
Accessories	Type	Order No.	Pcs./Pkt.
Radioline switchgear and controlgear assembly in impact-proof IP66 outdoor housing with universal power supply 100...240 V AC, surge protection and antenna feedthrough. Type of wireless module (frequency band), type and number of I/O extension modules are configurable.	RAD-RUGGED-BOX-CONF	1091638	1
Radioline - RS-485 multipoint multiplexer, can be extended with I/O modules, can be used as Modbus/RTU bus coupler or can be combined with Radioline wireless system, up to 99 stations, range of up to 1.2 km on in-house copper cables	RAD-RS485-IFS	2702184	1
Radioline - I/O extension module, 2 digital inputs and outputs (0 ... 250 V AC/DC) and 1 analog input (0/4 ... 20 mA) and output (0/4 ... 20 mA, 0 ... 10 V)	RAD-DAIO6-IFS	2901533	1
Radioline - I/O extension module, 4 digital inputs (0 ... 250 V AC/DC)	RAD-DI4-IFS	2901535	1
Radioline - I/O extension module, 4 digital relay outputs (5 A, 250 V AC/DC)	RAD-DOR4-IFS	2901536	1
Radioline - I/O extension module, 8 digital inputs (0 ... 30.5 V DC) or 2 pulse inputs up to 100 Hz	RAD-DI8-IFS	2901539	1
Radioline - I/O extension module, 4 NAMUR digital input module used in Radioline and PROFIBUS PA MUX I/O systems. Fulfills the NAMUR proximity sensor standard EN 60947-5-6, and communication to the head stations for Radioline systems and the FB-MUX/HS...PA via the T-BUS connector installed on the DIN rail. This module has channel-to-channel isolation.	RAD-NAM4-IFS	2316275	1
Radioline - I/O extension module, 8 digital transistor outputs (30.5 V DC/200 mA)	RAD-DO8-IFS	2902811	1
Radioline - I/O extension module, 4 analog current inputs (0/4 mA ... 20 mA)	RAD-AI4-IFS	2901537	1
Radioline - I/O extension module, 4 analog voltage inputs (0 ... 5 V, 0 ... 10 V)	RAD-AI4-U-IFS	2702290	1
Radioline - I/O extension module, 4 analog current or voltage outputs (0/4 mA ... 20 mA, 0 V ... 10 V)	RAD-AO4-IFS	2901538	1
Radioline - I/O extension module, 4 Pt 100 inputs (-50°C ... +250°C / -58 °F ... 482 °F)	RAD-PT100-4-IFS	2904035	1
DIN rail connector for DIN rail mounting. Universal for TBUS housing. Gold-plated contacts, 5-pos.	ME 17,5 TBUS 1,5/ 5-ST-3,81 GN	2709561	10

Accessories	Type	Order No.	Pcs./Pkt.
Radioline - configuration stick for easy and safe network addressing for the 2.4 GHz wireless module (RAD-2400-...), unique network ID, RF band 3	RAD-CONF-RF3	2902814	1
Radioline - configuration stick for easy and safe network addressing for the 2.4 GHz wireless module (RAD-2400-...), unique network ID, RF band 5	RAD-CONF-RF5	2902815	1
Radioline - configuration stick for easy and safe network addressing for the 2.4 GHz wireless module (RAD-2400-...), unique network ID, RF band 7	RAD-CONF-RF7	2902816	1
Radioline - memory stick for saving custom configuration data	RAD-MEMORY	2902828	1
Radioline - USB data cable for communication between the PC and Radioline devices, energy supply for diagnostics and configuration via the USB port of the PC, cable length: 2 m / 6.5 ft	RAD-CABLE-USB	2903447	1
Vulcanizing sealing tape for external protection of adapters, cable connections, etc. against the effects of weather, roll length: 3 m	RAD-TAPE-SV-19-3	2903182	1
Shield connection terminal block, for applying the shield to busbars	SKS 8-SNS35	3062786	10
Omnidirectional antenna, 2.4 GHz, gain: 2 dBi, polarization: linear, opening angle: h/v 360°/75°, degree of protection: IP65, connection: RSMA (male), incl. 1.5 m / 5 ft. connecting cable and mounting bracket for wall mounting	RAD-ISM-2400-ANT-OMNI-2-1-RSMA	2701362	1
Omnidirectional antenna with protection against vandalism, 2.4 GHz, gain: 3 dBi, polarization: linear, opening angle: h/v 360°/85°, degree of protection: IP55, connection: RSMA (male), for control cabinet mounting (optional wall mounting), incl. 1.5 m / 5 ft. connecting cable	RAD-ISM-2400-ANT-VAN-3-0-RSMA	2701358	1
Omnidirectional antenna, 2.4 GHz, gain: 6 dBi, polarization: linear, opening angle: h/v 360°/30°, degree of protection: IP67, seawater-resistant, connection: N (female), incl. mounting bracket and mast clips, ATEX and IECEx approval	RAD-ISM-2400-ANT-OMNI-6-0	2885919	1
Directional antenna, 2.4 GHz/5 GHz, gain: 9 dBi, polarization: linear, opening angle: h/v 75°/55°, degree of protection: IP67, seawater-resistant, connection: N (female), incl. mounting bracket and mast clips, ATEX and IECEx approval	ANT-DIR-2459-01	2701186	1
Antenna cable for control cabinet feed-through, outside diameter: 3.2 mm (0.126 in.), inner conductor: stranded, attenuation: 0.6 / 0.9 / 1.4 dB at 0.9 / 2.4 / 5.8 GHz, connection: N (female) -> RSMA (male), cable length: 0.5 m (1.6 ft.)	RAD-PIG-EF316-N-RSMA	2701402	1

Accessories	Type	Order No.	Pcs./Pkt.
Antenna cable, outside diameter: 5 mm (0.2 in.), inner conductor: solid, attenuation: 0.4 / 0.5 / 0.6 dB at 0.9 / 2.4 / 5.8 GHz, connection: N (male) -> RSMA (male), cable length: 0.5 m (1.6 ft.)	RAD-PIG-RSMA/N-0.5	2903263	1
Antenna cable, outside diameter: 5 mm (0.2 in.), inner conductor: solid, attenuation: 0.5 / 0.8 / 1.1 dB at 0.9 / 2.4 / 5.8 GHz, connection: N (male) -> RSMA (male), cable length: 1 m (3.3 ft.)	RAD-PIG-RSMA/N-1	2903264	1
Antenna cable, outside diameter: 5 mm (0.2 in.), inner conductor: solid, attenuation: 0.9 / 1.3 / 2.0 dB at 0.9 / 2.4 / 5.8 GHz, connection: N (male) -> RSMA (male), cable length: 2 m (6.5 ft.)	RAD-PIG-RSMA/N-2	2903265	1
Antenna cable, outside diameter: 5 mm (0.2 in.), inner conductor: solid, attenuation: 1.2 / 2.0 / 3.0 dB at 0.9 / 2.4 / 5.8 GHz, connection: N (male) -> RSMA (male), cable length: 3 m (10 ft.)	RAD-PIG-RSMA/N-3	2903266	1
Antenna cable, outside diameter: 5 mm (0.2 in.), inner conductor: solid, attenuation: 2.0 / 3.3 / 4.8 dB at 0.9 / 2.4 / 5.8 GHz, connection: N (male) -> RSMA (male), cable length: 5 m (16 ft.)	RAD-PIG-RSMA/N-5	2702140	1
Attachment plug with Lambda/4 technology as surge protection for coaxial signal interfaces Connection: N connectors socket-socket	CN-LAMBDA/4-5.9-BB	2838490	1
Antenna adapter for control cabinet feed-through, frequency range: 0.3 GHz ... 6 GHz, degree of protection: IP65, connection: 2 x N (female)	RAD-ADP-N/F-N/F	2867843	1
Antenna barrier for control cabinet feed-through, type of protection: Ex i, degree of protection: IP65, barrier installation: Zone 2 / 22, antenna installation: in dust and gas Ex area, frequency range: 0.3 GHz ... 6 GHz, connection: 2 x N (female), ATEX, EAC Ex and IECEx approval	BAR-ANT-N-N-EX	2702198	1
Antenna splitter, frequency range: 0.3 GHz ... 6 GHz, degree of protection: IP65, connection: 3 x N (female), suitable connection cable for the antenna connection (Order No. 2700677)	RAD-SPL-2-N/N	2702293	1
Antenna cable, outside diameter: 5 mm (0.2 in.), inner conductor: stranded, attenuation: 0.3/0.5/0.8 dB at 0.9 / 2.4 / 5.8 GHz, connection: 2 x N (male), cable length: 0.5 m (1.6 ft.)	FL LCX PIG-EF142-N-N	2700677	1
Antenna cable, outside diameter: 10 mm (0.4 in.), inner conductor: stranded, attenuation: 1.0/1.8/3.1 dB at 0.9/2.4 / 5.8 GHz, connection: 2 x N (male), cable length: 3 m (10 ft.)	RAD-CAB-EF393- 3M	2867649	1
Antenna cable, outside diameter: 10 mm (0.4 in.), inner conductor: stranded, attenuation: 1.6/2.9/5.0 dB at 0.9/2.4 / 5.8 GHz, connection: 2 x N (male), cable length: 5 m (16 ft.)	RAD-CAB-EF393- 5M	2867652	1
Antenna cable, outside diameter: 10 mm (0.4 in.), inner conductor: stranded, attenuation: 2.9/5.6/9.9 dB at 0.9/2.4 / 5.8 GHz, connection: 2 x N (male), cable length: 10 m (32 ft.)	RAD-CAB-EF393-10M	2867665	1

Accessories	Type	Order No.	Pcs./Pkt.
Antenna cable, outside diameter: 10 mm (0.4 in.), inner conductor: stranded, attenuation: 4.3 / 8.3 / 14.8 dB at 0.9 / 2.4 / 5.8 GHz, connection: 2 x N (male), cable length: 15 m (50 ft.)	RAD-CAB-EF393-15M	2885634	1
Primary-switched MINI POWER supply for DIN rail mounting, input: 1-phase, output: 24 V DC/1.5 A	MINI-SYS-PS-100-240AC/24DC/1.5	2866983	1
<b>Second generation</b> FL COMSERVER UNI..., serial device server for converting a serial 232/422/485 interface to Ethernet, supports TCP, UDP, Modbus gateway, and PPP applications, incl. COM port redirector software and user documentation	FL COMSERVER UNI 232/422/485	2313452	1
Antenna adapter, frequency range: 0.3 GHz ... 6 GHz, connection: RSMA (male) -> RSMA (female), 90° angled	RAD-ADP-RSMA/M-RSMA/F-90	2904790	1
Surge protection, consisting of protective plug and base element, with integrated status indicator and knife disconnection for three signal wires with common reference potential. For HF applications and telecommunications interfaces without supply voltage. Indirect grounding via gas-filled surge arrester.	TTC-6P-3-HF-F-M-12DC-PT-I	2906796	1

## 4 Technical data

### Dimensions

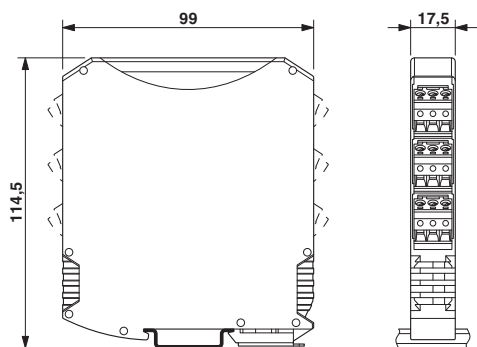

Dimensions W/H/D	17.5 mm / 116 mm / 114.5 mm
------------------	-----------------------------

### General data

Overvoltage category	II
Degree of protection	IP20
Degree of pollution	2
Type of housing	PA 6.6-FR, green
Flammability rating according to UL 94	V0

<b>General data</b>	
MTTF (mean time to failure) Telcordia standard, 25°C temperature, 21% operating cycle (5 days a week, 8 hours a day)	778 Years
MTTF (mean time to failure) Telcordia standard, 40°C temperature, 34.25% operating cycle (5 days a week, 12 hours a day)	358 Years
MTTF (mean time to failure) Telcordia standard, temperature 40 °C, operating cycle 100 % (7 days a week, 24 hours a day)	142 Years
<b>Supply</b>	
Supply voltage range	19.2 V DC ... 30.5 V DC
Max. current consumption	≤ 65 mA (at 24 V DC, at 25 °C, stand-alone) ≤ 6 A (at 24 V DC, with DIN rail connector at full capacity)
Transient surge protection	Yes
<b>System limits</b>	
Wireless module, number of supported devices	≤ 250 (addressing via PSI-CONF software) ≤ 99 (addressing via thumbwheel)
Wireless module, number of possible extension modules	≤ 32 (per wireless module)
Wireless network, number of supported devices, I/O data mode	≤ 99 (I/O extension modules per wireless network, serial interfaces deactivated)
Wireless network, number of supported devices, Serial data mode	0 (no I/O extension modules can be used)
Wireless network, number of supported devices, PLC/Modbus RTU mode	≤ 99 (I/O extension modules per wireless network, access to extension modules via Modbus/RTU protocol)
<b>Wireless interface</b>	
Antenna connection method	RSMA (female)
Direction	Bi-directional
Frequency	2400 MHz
Frequency range	2.4002 GHz ... 2.4785 GHz
Number of channel groups	8
Number of channels per group	55
Channel distance	1.3 MHz
Data transmission rate (adjustable)	16 kbps 125 kbps 250 kbps
Receiver sensitivity	-106 dBm (16 kbps) -96 dBm (125 kbps) -93 dBm (250 kbps)
Transmit capacity, maximum	≤ 20 dBm (outside of Europe, adjustable via software) ≤ 19 dBm (Europe, can be set via software, depends on the data rate) 18 dBm (default setting, adjustable)
Security	128-bit data encryption

**RS-232, 3-wire**

Connection method	COMBICON plug-in screw terminal block
Transmission speed	300 bps 600 bps 1.2 kbps 2.4 kbps 4.8 kbps 9.6 kbps 19.2 kbps 38.4 kbps 57.6 kbps 93.75 kbps 115.2 kbps
Transmission length	≤ 15 m

**RS-485, 2-wire**

Connection method	COMBICON plug-in screw terminal block
Transmission speed	300 bps 600 bps 1.2 kbps 2.4 kbps 4.8 kbps 9.6 kbps 19.2 kbps 38.4 kbps 57.6 kbps 93.75 kbps 115.2 kbps 187.5 kbps
Transmission length	≤ 1200 m
Termination resistor (switchable via DIP switches)	390 Ω / 150 Ω / 390 Ω

**RSSI voltage output**

Number of outputs	1
Voltage output signal	0 V ... 3 V

**RF link relay output**

Number of outputs	1
Contact type	PDT
Contact material	PdRu, gold-plated
Maximum switching voltage	30 V AC/DC 60 V DC
Max. switching current	500 mA (30 V AC/DC) 300 mA (60 V DC)
Electrical service life	5x 10 <sup>5</sup> switching cycles with 0.5 A at 30 V DC

Connection data	
Connection method	Screw connection
Conductor cross section, solid	0.2 mm <sup>2</sup> ... 2.5 mm <sup>2</sup>
Conductor cross section, flexible	0.2 mm <sup>2</sup> ... 2.5 mm <sup>2</sup>
Conductor cross section AWG/kcmil	24 ... 14
Stripping length	7 mm
Tightening torque	0.6 Nm

Status indication	
Status display	Green LED (supply voltage, PWR) Green LED (bus communication, DAT) Red LED (periphery error, ERR) 3x green, 1x yellow LED (LED bar graph receive quality, RSSI) Green LED (receive data, RX) Green LED (transmit data, TX)

Ambient conditions	
Ambient temperature (operation)	-40 °C ... 70 °C (>55°C derating) -40 °F ... 158 °F (>131°F derating)
Ambient temperature (storage/transport)	-40 °C ... 85 °C -40 °F ... 185 °F
Permissible humidity (operation)	20 % ... 85 %
Permissible humidity (storage/transport)	20 % ... 85 %
Altitude	2000 m
Vibration (operation)	in accordance with IEC 60068-2-6: 5g, 10 Hz ... 150 Hz
Shock	16g, 11 ms

#### Operating conditions for the extended temperature range (+55 °C ... 70 °C)



Please observe any restrictions which are described in the product documentation of the extension modules used.

Certification	
Conformance	CE-compliant (RED Directive 2014/53/EU) FCC Directive, Part 15.247 ISC Directive RSS 210 IFT RCPPHRA17-1112
ATEX Please follow the special installation instructions in the documentation!	Ⓜ II 3 G Ex nA nC IIC T4 Gc (IBExU 15 ATEX B008 X)
IECEX	Ex nA nC IIC T4 Gc (IECEX IBE 13.0019X)
EAC Ex	2Ex nA nC IIC T4 Gc X (TC RU C-DE.AB72.B.01483)
UL, USA/Canada	UL 508 Listed Class I, Div. 2, Groups A, B, C, D T4A Class I, Zone 2, IIC T4
Noxious gas test	ISA-S71.04-1985 G3 Harsh Group A

**Conformance with EMC Directive 2014/30/EU****Noise immunity according to EN 61000-6-2**

Electrostatic discharge	EN 61000-4-2	
	Contact discharge	± 6 kV (Test Level 3)
	Discharge in air	± 8 kV (Test Level 3)
	Indirect discharge	± 6 kV
	Comments	Criterion B
Electromagnetic HF field	EN 61000-4-3	
	Frequency range	26 MHz ... 3 GHz (Test Level 3)
	Field intensity	10 V/m
	Comments	Criterion A
Fast transients (burst)	EN 61000-4-4	
	Input	± 2 kV (Test Level 3)
	Signal	± 2 kV
	Comments	Criterion B
Surge current loads (surge)	EN 61000-4-5	
	Input	± 0.5 kV (symmetrical) ± 1 kV (asymmetrical)
	Signal	± 1 kV (asymmetrical)
	Comments	Criterion B
Conducted interference	EN 61000-4-6	
	Frequency range	0.15 MHz ... 80 MHz
	Voltage	10 V
	Comments	Criterion A

**Emitted interference in acc. with EN 61000-6-4**

Emitted radio interference in acc. with EN 55011	EN 55016-2-3 Class A industrial applications
Criterion A	Normal operating behavior within the specified limits
Criterion B	Temporary impairment of operating behavior that is corrected by the device itself

**Conformance with RED Directive 2014/53/EU**

EMC - immunity to interference (electromagnetic compatibility of wireless systems)	EN 61000-6-2, Generic standard for the industrial sector
Safety - protection of personnel with regard to electrical safety	EN 60950
Health - limitation of exposure of the population to electromagnetic fields	EN 62311
Radio - effective use of the frequency spectrum and prevention of radio interference	EN 300328

## 5 Safety regulations and installation notes

### 5.1 Intended use

The devices are intended for application in industrial environments.

The wireless system is Class A equipment and may cause radio interference in residential areas. In this case, the operator may be required to implement appropriate measures and to pay the costs incurred as a result.

Please note that, in combination with antennas, the maximum permissible transmission power may be exceeded. In this case, set the transmission power via the software (see Section 7.3 "Transmission power").



Install the wireless module at least 1 m away from other devices using the 2.4 GHz frequency band (e.g., WLAN, Bluetooth, microwave ovens). Otherwise, both the transmission quality and data transmission rate will be reduced.

### 5.2 Installation notes



#### **WARNING: Risk of electric shock**

During operation, certain parts of this device may carry hazardous voltages. Disregarding this warning may result in damage to equipment and/or serious personal injury.

- Provide a switch/circuit breaker close to the device, which is labeled as the disconnect device for this device or the entire control cabinet.
- Provide overcurrent protection ( $I \leq 6 \text{ A}$ ) in the installation.
- Disconnect the device from all power sources during maintenance work and configuration (the device can remain connected to SELV or PELV circuits).
- The housing of the device provides a basic insulation against the neighboring devices, for 300 V eff. If several devices are installed next to each other, this has to be taken into account, and additional insulation has to be installed if necessary. If the neighboring device is equipped with basic insulation, no additional insulation is necessary.

- Operation of the wireless system is only permitted when using accessories available from Phoenix Contact. The use of any other components can lead to the withdrawal of the operating license.
- Phoenix Contact hereby declares that this wireless system complies with the basic requirements and other relevant regulations specified in Directive 2014/53/EU.
- The category 3 device is designed for installation in zone 2 potentially explosive areas. It meets the requirements of EN 60079-0:2012+A11:2013 and EN 60079-15:2010.
- Installation, operation, and maintenance may only be carried out by qualified electricians. Follow the installation instructions as described.
- When installing and operating the device, the applicable regulations and safety directives (including national safety directives), as well as general technical regulations, must be observed. The technical data is provided in the package slip and on the certificates (conformity assessment, additional approvals where applicable).

- The device must not be opened or modified. Do not repair the device yourself, replace it with an equivalent device. Repairs may only be carried out by the manufacturer. The manufacturer is not liable for damage resulting from violation.
- The IP20 protection (IEC 60529/EN 60529) of the device is intended for use in a clean and dry environment. The device must not be subject to mechanical strain and/or thermal loads, which exceed the limits described.
- To protect the device against mechanical or electrical damage, install it in a suitable housing with appropriate degree of protection as per IEC 60529.
- The device complies with the EMC regulations for industrial areas (EMC class A). When using the device in residential areas, it may cause radio interference.
- Only specified devices from Phoenix Contact may be connected to the 12-pos. S-PORT interface.
- The device is not designed for use in atmospheres with a danger of dust explosions.
- If dust is present, it is necessary to install into a suitable approved housing, whereby the surface temperature of the housing must be taken into consideration.

### 5.3 Installation in Zone 2



**WARNING: Explosion hazard when used in potentially explosive areas**

Please make sure that the following notes and instructions are observed.

- Observe the specified conditions for use in potentially explosive areas! Install the device in a suitable, approved housing that meets the requirements of IEC/EN 60079-15 and has at least IP54 protection. Also observe the requirements of IEC/EN 60079-14.
- In zone 2, only connect devices to the supply and signal circuits that are suitable for operation in the Ex zone 2 and the conditions at the installation location.
- In potentially explosive areas, terminals may only be snapped onto or off the DIN rail connector and wires may only be connected or disconnected when the power is switched off.
- The switches of the device that can be accessed may only be actuated when the power supply to the device is disconnected.
- The device must be stopped and immediately removed from the Ex area if it is damaged, was subject to an impermissible load, stored incorrectly or if it malfunctions.
- Ensure that the radiated wireless power is neither bundled (focused) by the antenna itself nor by any inserts in the environment of the antenna, and that it cannot enter neighboring zones 1 or 0. For the transmission power, please refer to the technical data.
- The HF cable to the antenna must be suitable for the ambient conditions. Install the cable such that it is protected against mechanical damage, corrosion, chemical stress, and negative effects from heat or UV radiation. The same applies to the antenna which is connected to the cable and which functions as a cable termination.
- The antenna must meet the requirements of EN 60079-0 with regard to housing and electrostatic discharge. Otherwise install the antenna in housing that meets the requirements of EN 60079-0 and EN 60079-15 and has at least IP54 protection (EN 60529).

### Notes for antennas

- Avoid electrostatic charges.
- Install the antenna outside the reach of persons.
- Only clean the antenna housing using a suitable damp cloth.
- The antenna must be stopped and immediately removed from the Ex area if it is damaged, was subjected to an impermissible load, stored incorrectly or if it malfunctions.
- Observe the safety notes in the documentation for the respective antenna.

### 5.4 UL notes



**WARNING: Explosion hazard when used in potentially explosive areas**

Please make sure that the following notes and instructions are observed.

#### INDUSTRIAL CONTROL EQUIPMENT FOR HAZARDOUS LOCATIONS 45FP

- A This equipment is suitable for use in Class I, Zone 2, IIC T4 and Class I, Division 2, Groups A, B, C, D T4A hazardous locations or non-hazardous locations only.
- B **WARNING - EXPLOSION HAZARD - DO NOT DISCONNECT EQUIPMENT UNLESS POWER HAS BEEN SWITCHED OFF OR THE AREA IS KNOWN TO BE NON-HAZARDOUS.**
- C **WARNING - EXPLOSION HAZARD - SUBSTITUTION OF COMPONENTS MAY IMPAIR SUITABILITY FOR CLASS 1, DIVISION 2.**
- D These devices are open-type devices that are to be installed in an enclosure suitable for the environment that is only accessible with the use of a tool.
- E **WARNING - Exposure to some chemicals may degrade the sealing properties of materials used in relays within this device.**
- F **WARNING - EXPLOSION HAZARD - S-PORT IS FOR MAINTENANCE AND PROGRAMMING ONLY AND SHOULD ONLY BE USED WHEN THE AREA IS KNOWN TO BE NON-HAZARDOUS.**

### 5.5 Approvals and conformity



The device is approved for license-free operation in Europe and other countries. A list of the country approvals is available at [phoenixcontact.net/product/2901541](http://phoenixcontact.net/product/2901541).  
Additional country approvals on request

The RAD-2400-IFS wireless transceiver uses the toll- and license-free 2.4 GHz ISM band.

The device satisfies all requirements of the directive 2014/53/EU. Further information is available in the manufacturer's declaration at [phoenixcontact.net/product/2901541](http://phoenixcontact.net/product/2901541).

Depending on the maximum possible transmission power, it is necessary to notify use of the device or to apply for an approval for use in some countries. Furthermore, it may be necessary to limit the transmission power.

- Observe the regulations of the relevant regulatory body in all countries.

**FCC**

This device complies with Part 15 of the FCC rules. Operation is subject to the following two conditions:  
 (1) This device may not cause harmful interference.  
 (2) This device must accept any interference received, including interference that may cause undesired operation.

**NOTE: Interference**

This equipment has been tested and found to comply with the limits for a Class A digital device, pursuant to part 15 of the FCC rules. These limits are designed to provide reasonable protection against harmful interference when the equipment is operated in a commercial environment. This equipment generates, uses and can radiate radio frequency energy and, if not installed and used in accordance with the instruction manual, may cause harmful interference to radio communications. Operation of this equipment in a residential area is likely to cause harmful interference, in which case, the user will be required to correct the interference at his own expense.

Any changes or modifications not explicitly approved by Phoenix Contact could cause the device to cease to comply with FCC rules Part 15, and thus void the user's authority to operate the equipment.

Radio frequency exposure:

The device contains a radio transmitter and receiver. During communication the device receives and transmits radio frequency (RF) electromagnetic fields (microwaves) in the frequency range of 2400 MHz to 2483.5 MHz.

RF Exposure Statement:

This equipment should be installed and operated with a minimum distance of 20 cm between the radiator and your body.

This transmitter must not be co-located or operating in conjunction with any other antenna or transmitter.

This device contains:

FCC ID: YG3RAD2400A

**Industry Canada (IC)**

Operation is subject to the following two conditions: (1) this device may not cause interference, and (2) this device must accept any interference, including interference that may cause undesired operation of the device.

This device has been designed to operate with an antenna having a maximum gain of 9 dBi.

Having a higher gain is strictly prohibited per regulations of Industry Canada. The required antenna impedance is 50 ohms.

To reduce potential radio interference to other users, the antenna type and its gain should be so chosen that the equivalent isotropically radiated power (EIRP) is not more than that permitted for successful communication.

This device contains:

IC certificate: 4720B-RAD2400A

**IFT, Instituto Federal de Telecomunicaciones México**

The operation of this equipment is subject to the following two conditions: (1) it is possible that this equipment or device may not cause harmful interference, and (2) this equipment or device must accept any interference including interference that may cause its undesired operation.

This equipment has been designed to operate with antennas listed below and for an antenna's maximum gain of 19 dBi. Use of this equipment with antennas not included in this list or having a higher gain than 19 dBi is prohibited. The required antenna impedance is 50 ohms.

Certificate number:

IFT RCPPHRA17-1112

– Antennas: see section 3 "Ordering data"

---

**NCC****第十二條**

經型式認證合格之低功率射頻電機，非經許可，公司、商號或使用者均不得擅自變更頻率、加大功率或變更原設計之特性及功能。

**第十四條**

低功率射頻電機之使用不得影響飛航安全及干擾合法通信；經發現有干擾現象時，應立即停用，並改善至無干擾時方得繼續使用。前項合法通信，指依電信法規定作業之無線電通信。低功率射頻電機須忍受合法通信或工業、科學及醫療用電波輻射性電機設備之干擾。

ID: CCAJ18LP1990T7

## 6 Installation



**NOTE: electrostatic discharge!**  
 Electrostatic discharge can damage or destroy components.  
 – When handling the device, observe the necessary safety precautions against electrostatic discharge (ESD) according to EN 61340-5-1 and IEC 61340-5-1.

### 6.1 Product description

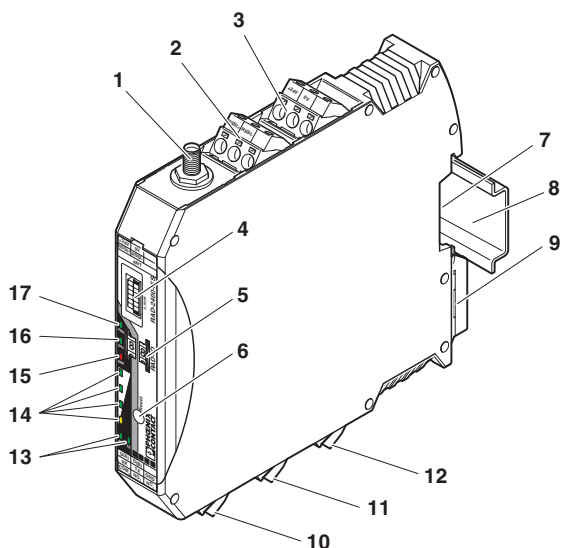

Figure 1 Function elements

Pos.	Terminal block	Designation
1		RSMA antenna connection (socket)
2	2.1 / 2.2	Test output RSSI (0...3 V DC) for evaluation of the wireless signal strength
3	1.1 / 1.2	Device supply (+24 V DC, GND)
4		12-pos. programming interface (S-PORT)
5		RAD ID address setting via thumbwheel
6		SET button
7		Connection option for DIN rail connector
8		DIN rail
9		Metal foot catch for DIN rail fixing
10	4.1 / 4.2	Connection terminal block RS-485 interface
11	5.1 / 5.2 / 5.3	Connection terminal block RS-232 interface
12	6.1 / 6.2 / 6.3	Relay output with PDT contact (floating)
13		RS-232/485 serial interface status LED (RX/TX)
14		LED bar graph for displaying the wireless signal strength
15		ERR status LED, red (communication error)
16		DAT status LED, green (bus communication)
17		PWR status LED, green (supply voltage)

### 6.2 Basic circuit diagram

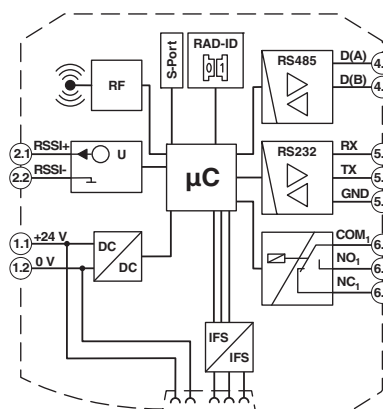

Figure 2 Basic circuit diagram

### 6.3 Display and diagnostic elements

The wireless module indicates the operating states with nine LEDs.

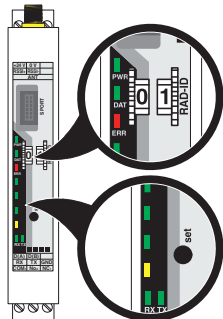

Figure 3 Display and diagnostic elements

#### PWR-LED

The green PWR LED indicates the supply voltage status.

Off	no supply voltage
On	Supply voltage OK

#### DAT-LED

The green DAT LED indicates the bus communication status.

Off	no communication
Flashing	Configuration mode
On	Cyclic data communication

#### ERR-LED

The red ERR LED indicates the error status.

Off	no error	
Flashing	Slow (1.4 Hz)	<b>Wireless module in I/O data mode (wire in/wire out):</b> double assignment of the I/O MAP address, missing input module, missing output module, modified RAD ID <b>Wireless module in PLC/Modbus RTU mode:</b> double assignment of the I/O MAP address, modified RAD ID, no Modbus communication
	Fast (2.8 Hz)	Wireless connection interrupted
On		Local bus error

## LED bar graph

The LED bar graph indicates the receive signal strength.

Bar graph	LEDs	Receive signal	RSSI (in V)	
	All 4 LEDs light up	Connection with maximum receive signal	2.5 ... 3 V	
		16k		-70 dBm
		125k		-65 dBm
		250k		-60 dBm
	Yellow and 2 green LEDs light up	Connection with very good receive signal	2 ... 2.5 V	
		16k		-80 dBm
		125k		-75 dBm
		250k		-70 dBm
	Yellow and 1 green LEDs light up	Connection with good receive signal	1.5 ... 2 V	
		16k		-90 dBm
		125k		-85 dBm
		250k		-80 dBm
	Yellow LED lights up	Connection with low receive signal	1 ... 1.5 V	
		16k		LINK
		125k		LINK
		250k		LINK
	Off	No connection	0 V	

## LED bar graph - light sequence

The light sequence from bottom to top signalizes a firmware update or that the wireless module is in write mode for the memory stick.

## LED bar graph - flashing

The devices are too close to each other.



The antenna is mounted outside the control cabinet/building. Observe the installation instructions for the antenna used. See also 5 "Safety regulations and installation notes".

As the full transmission power and the reception amplifier are activated by default, signals may be superimposed. Increase the distance between devices.

## TX-LED

The green TX LED indicates communication (transmit data) with the RS-232/RS-485 interface.

From firmware version 1.70: in I/O data mode, the TX-LED on the wireless master flashes (RAD-ID = 01). This indicates that the wireless master continually emits search requests to RS-485 stations.

## RX-LED

The green RX LED indicates communication (receive data) with the RS-232/RS-485 interface.

## SET button

The SET button is used to confirm a station change, without performing a power up.

After making any change, press the SET button for one second to apply the settings. The DAT LED starts flashing. When the DAT LED is permanently on this means that read in has been completed.

Station changes:

- RAD ID address of the wireless module changed
- I/O MAP address of extension modules changed
- I/O extension module added
- I/O extension module removed
- Memory stick used
- CONFSTICK used

### RSSI LED bar graph

You can read the RSSI values (signal strength received) via the serial interface of the master wireless module by Modbus/RTU commands.

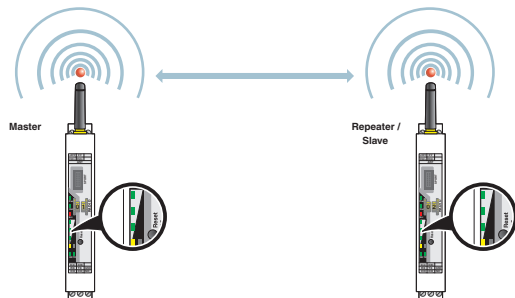

Figure 4 Example of point-to-point connection

In a point-to-point connection, the LED bar graph is active on the master and on the repeater/slave. The same signal strength is displayed on both modules.

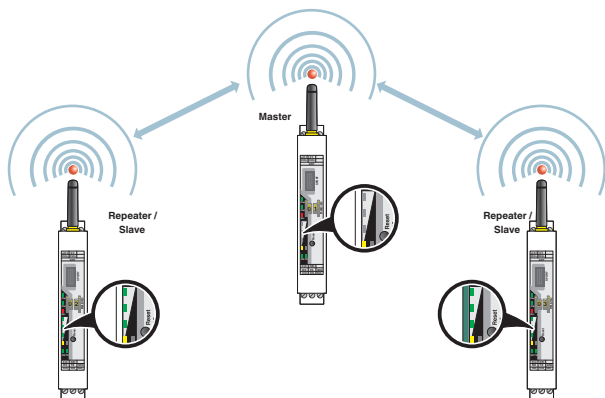

Figure 5 Example of multipoint-to-point connection

In a wireless network with more than one repeater/slave, only the yellow LED on the master is permanently on. The signal strength is displayed on the repeaters/slaves. The signal strength is always related to the wireless module which is directly connected.

### RF link relay

The RF link relay in the transceiver diagnoses the state of the wireless connection. It picks up when the wireless connection is established. If no data packets are received correctly over a period of 10 seconds, the relay drops out again. It picks up again automatically when the wireless connection is re-established.

The RF link relay has been designed as a PDT contact.



The RF link relay can be used as a fault message contact to indicate the failure of the wireless connection to the controller.

### RSSI test socket

A voltage measuring device can be connected to the RSSI test socket (2.1/2.2) to measure the RSSI voltage from 0 V ... 3 V. You can use the "LED bar graph" table to determine the received signal strength based on the measured voltage. This can be useful when positioning and aligning the antenna, for example.

## 6.4 Mounting and removing

### Connection station with I/O extension modules

Up to 32 different I/O extension modules can be connected to every wireless module via the DIN rail connector (see accessories). Data is transmitted and power is supplied to the I/O extension modules via the bus foot.

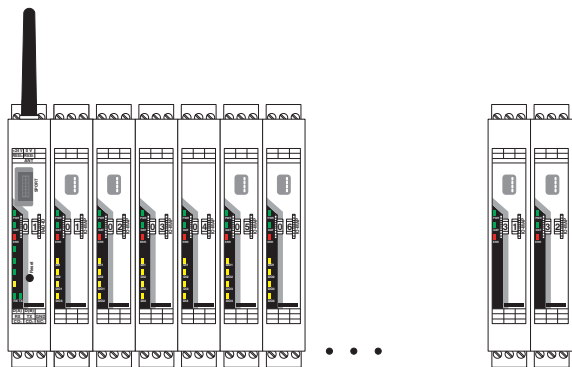

Figure 6 Radioline connection station with up to 32 I/O extension modules



Only mount the I/O extension modules to the right of the wireless module.

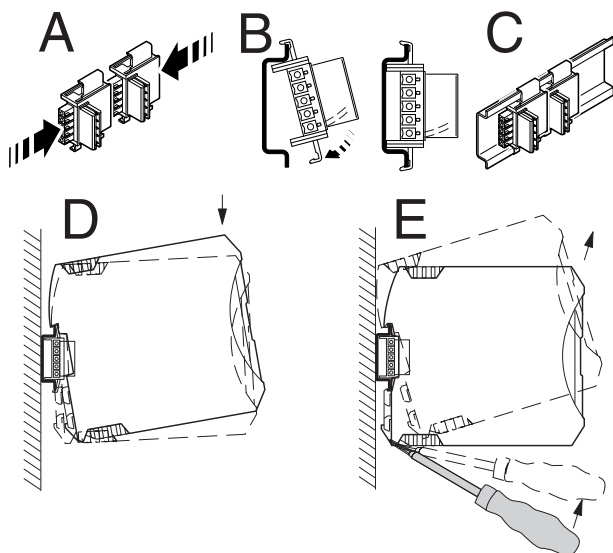

Figure 7 Mounting and removing

### Mounting

When using the device in a connection station, use the 17.5 mm wide DIN rail connector supplied. Only use the DIN rail connector in connection with 24 V DC devices.



Outside the Ex area, module extension or module replacement is also possible during operation.

- Connect the DIN rail connectors together for a connection station.
- Push the connected DIN rail connectors into the DIN rail.
- Place the device onto the DIN rail from above. Ensure the device and DIN rail connector are aligned correctly.
- Holding the device by the housing cover, carefully push the device towards the mounting surface so that the device bus connector is securely fixed onto the DIN rail connector.
- Once the snap-on foot has been audibly snapped onto the DIN rail, check that it is fixed securely. The device is only mechanically secured via the DIN rail.
- Connect the desired number of I/O extension modules to the wireless module via the DIN rail connector.
- In order to meet the requirements for the protection class, install the device in suitable housing.
- During startup, check that the device is operating, wired, and marked correctly.
- You can establish a connection between two DIN rail connectors using MINI COMBICON connectors: MC 1,5/5-ST-3,81 (female, 1803604); IMC 1,5/5-ST-3,81 (male, 1857919).

### Removing

- Use a suitable screwdriver to release the locking mechanism on the snap-on foot of the device.
- Hold onto the device by the housing cover and carefully tilt it upwards.
- Carefully lift the device off the DIN rail connector and the DIN rail.

### 6.5 Connecting cables

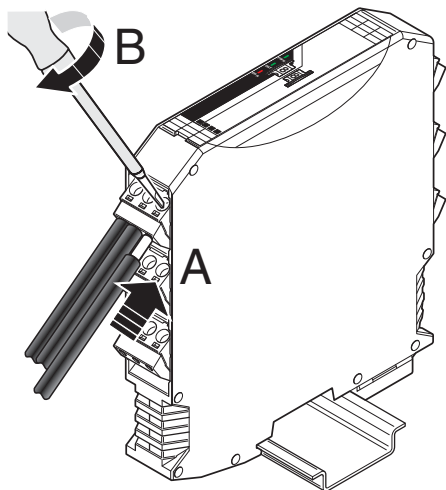

Figure 8 Connecting cables

- Crimp ferrules to the wires.  
Permissible cable cross section: 0.2...2.5 mm<sup>2</sup>.
- Insert the wire with ferrule into the corresponding connection terminal block.
- Use a screwdriver to tighten the screw in the opening above the connection terminal block.  
Tightening torque: 0.6 Nm

### 6.6 Serial pin assignment

Connect the I/O device to the wireless module via the required serial interface.



Parallel operation of the interfaces is not possible.

### Shielding

- Connect the shield of the RS-485 bus line correctly via an external shield connection clamp (e.g. SKS 8-SNS35, Order No. 3062786).



**NOTE: damage to the interface**

A faulty connection of the shield in combination with permanent external interferences can cause damage to the RS-485 interface.

Observe the polarity of the RS-485 2-wire cable and ensure that the shield connection is connected correctly.

Choose the type of shield connection according to the type of interference expected:

- Firstly, connect the shield on one side. This suppresses electrical fields.
- To suppress disturbances caused by alternating magnetic fields, connect the shield on both sides. When doing so, the ground loops must be taken into account: galvanic disturbances along the reference potential can interfere with the useful signal, and the shielding effect is reduced.
- If several devices are connected to a single bus, the shield must be connected to each device (e.g., by means of clamps).
- Connect the bus shield to a central PE point using short, low-impedance connections with a large surface area (e.g., by means of shield connection clamps).

### Termination network

The wireless module is operated on a 2-wire bus line. For correct operation of the bus system, termination networks are required for the RS-485 bus connection.

- Terminate an RS-485 bus cable at both bus ends. To do so, verify the position of the wireless module on the RS-485 bus cable and set the required operating mode via the DIP switch.

		DIP	
Operating mode	Termination network	1	2
RS-485 termination device	On	ON	ON
RS-485 device	Off	OFF	OFF

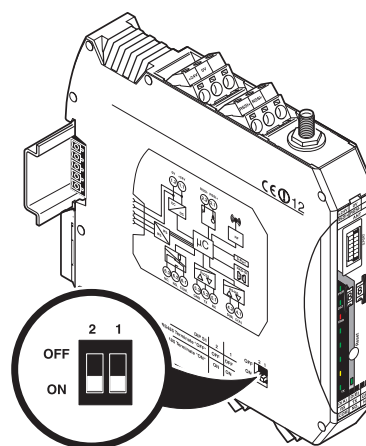

Figure 9 DIP switches

### RS-485 pin assignment

In RS-485 mode, an RS-485 network with several I/O devices can be created. Use a twisted pair bus cable to connect the I/O devices. Fit this bus cable with a termination network at the two furthest points of the RS-485 network.

- Connect the individual conductors of the data cable to the COMBICON plug-in screw terminal block (Figure 1, item 10).
- Make sure the signal assignment is correct.

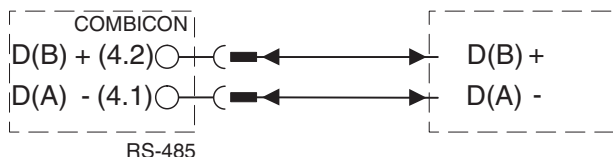

Figure 10 RS-485 interface pin assignment

### RS-232 pin assignment

In RS-232 mode, point-to-point connections can be established.



The RS-232 interface is a DTE (data terminal equipment) type.

Only connect the wireless module to devices which meet the requirements of EN 60950.

- Connect the individual conductors of the data cable to the COMBICON plug-in screw terminal block (Figure 1, item 11).
- Make sure the signal assignment is correct.

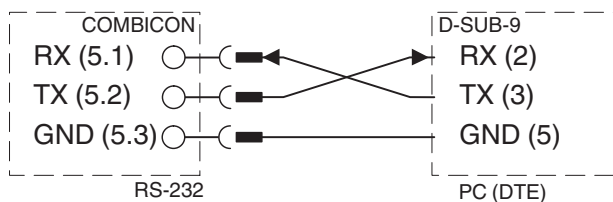

Figure 11 RS-232 interface pin assignment (DTE - DTE)

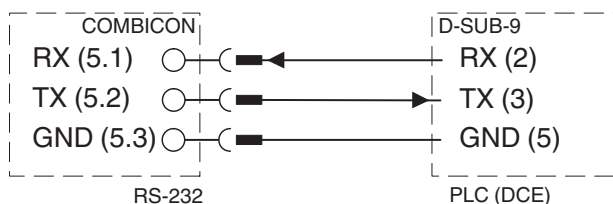

Figure 12 RS-232 interface pin assignment (DTE - DCE)

### Antenna connection

The wireless module has an RSMA antenna connection (socket) for connecting an external antenna.

A wide selection of antennas and antenna cables can be found in the "Ordering data" section on page 3.

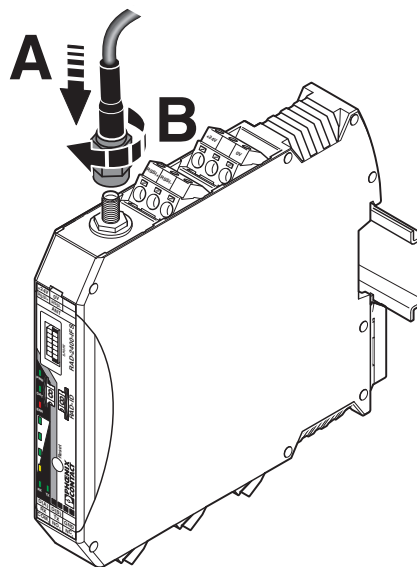

Figure 13 Antenna connection

## 7 Startup and configuration

By default, all wireless modules are configured in the same way.

### Default settings

Operating mode: I/O data mode (wire in/wire out)



Data communication is only possible using I/O extension modules.

### Wireless interface

Net ID:	127
RF band:	4
Encryption:	Off
Network structure:	Mesh
Device type:	Repeater/slave
Blacklisting:	Channel 6 (WLAN)
Data rate of the wireless interface:	125 kbps
Reception amplifier:	Activated
Transmission power:	18 dBm

For simple I/O data applications (wire in/wire out), addressing is carried out easily using a thumbwheel. You can therefore establish a wireless connection to other RAD-2400-IFS devices without any programming effort.

For serial data transmission, PLC/Modbus RTU mode or changes to the "default settings", each wireless module must be configured using the PSI-CONF configuration and diagnostics software. See Section 7.6 "PSI-CONF configuration and diagnostics software".

If you operate the system in an environment with more than one network in the 2.4 GHz band or other networks (e.g., WLAN), you can use a configuration memory (CONFSTICK). You can also make extended settings using the PSI-CONF software.

### 7.1 Resetting to the default settings

- Disconnect the device from the supply voltage.
- Hold down the SET button located on the front of the device.
- Switch the supply voltage back on.
- Press and hold the SET button until the DAT LED flashes.

Alternatively, you can reset the device to the default settings using the PSI-CONF software.

### 7.2 Setting the station address (RAD-ID)

You address the devices in a wireless network via the thumbwheel on the front of the wireless module.

Firstly, set the desired station address with the yellow thumbwheel on the wireless module. This results in an initial functional configuration. There must be one master (address "01") and at least one repeater/slave (address "02 to 99") in a network.



Each address in a network must be unique.

If two wireless modules in a network have the same address, the network will not function correctly.

The following settings can be made using the thumbwheel:

Thumbwheel	Description
01	Master address for networks with repeaters (mesh networks)
02 - 99	Repeater/slave addresses for networks with repeaters (mesh networks)
*1	Master address for networks without repeaters (star networks)
*2 - *9	Slave address for networks without repeaters (star networks)
00	Not permitted
**	Addressing wireless modules using the PSI-CONF configuration and diagnostics software (address 1 ... 250)



Setting the address via the thumbwheel has priority over setting the address via the PSI-CONF configuration and diagnostics software.

To apply the configuration, press the SET button for one second in the event of the following changes:

- RAD ID address of the wireless module changed
- I/O MAP address of extension modules changed
- I/O extension module added
- I/O extension module removed

### 7.3 Transmission power



Observe the maximum permissible radiated transmission power at the antenna (EIRP, see table).  
 This is determined based on:  
 Device transmission power + antenna gain  
 - cable attenuation.  
 Reduce the device transmission power via the PSI-CONF software, if necessary.

### 7.4 Data transmission speed of the wireless interface

The range is an important parameter in industrial wireless applications, especially in outdoor applications.

Even in cases where long ranges do not have to be covered, good receiver sensitivity enables transmission in harsher outdoor conditions, e.g., when there is no direct line of sight.

The receiver sensitivity determines the signal amplitude which can just about be received by the wireless module. The lower the data transmission speed of the wireless interface, the higher the receiver sensitivity and thereby the bandwidth.

You can achieve transmission within the kilometer range using the wireless module if the following conditions are fulfilled:

- Suitable gain antennae are used
- Line of sight
- Adherence to the Fresnel zone

Data transmission speed [kbps]	Typical receiver sensitivity [dBm]	EIRP: max. radiated power [dBm]	Potential distance that can be covered with line of sight and a system reserve of 12 dB [m]
250	-93	20 (Europe: 19)	1000
125	-96	20 (Europe: 18)	3000 (Europe: 2000)
16	-106	20 (Europe: 11)	5000 (Europe: 3000)

- Adjust the data transmission speed of the wireless interface to the respective application using the PSI-CONF software (default setting = 125 kbps).

### 7.5 Operating modes

The Radioline wireless system provides four different options for signal and data transmission.

Default setting, configuration only possible via thumbwheel:

- I/O data mode

Configuration via PSI-CONF software:

- PLC / Modbus/RTU mode
- PLC / Modbus/RTU dual mode
- Serial data mode

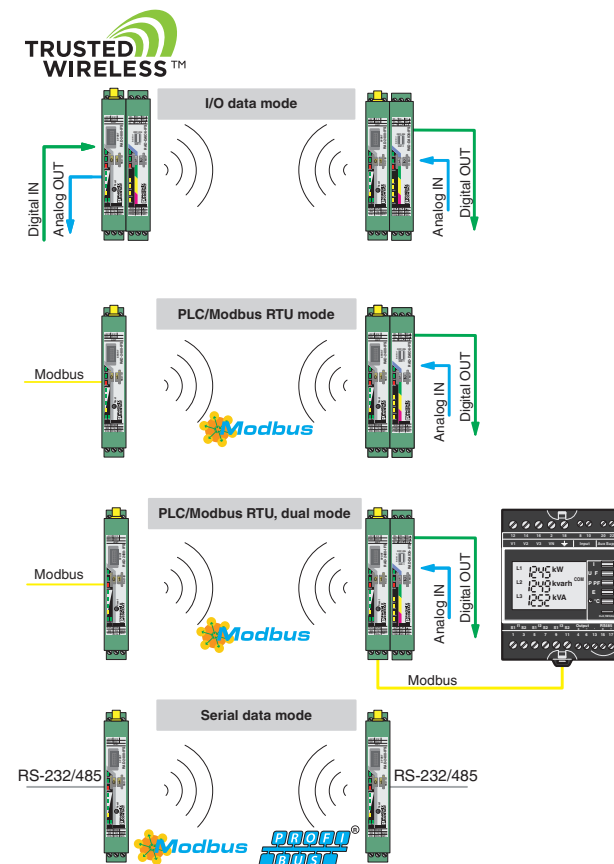

Figure 14 Operating modes

## 7.6 PSI-CONF configuration and diagnostics software

The PSI-CONF software is required for special settings. It can be downloaded at [phoenixcontact.net/product/2901541](http://phoenixcontact.net/product/2901541).

A PC with a Windows operating system is required for configuration. Use the RAD-CABLE-USB cable (Order No. 2903447) for configuration and diagnostics.



**WARNING: Explosion hazard when used in potentially explosive areas**

Do not insert or remove the cable in a potentially explosive atmosphere!

## 7.7 Behavior of the input and output modules in the event of an interrupted wireless connection

DIP switches on the I/O extension modules can be used to set how the analog and digital outputs should behave in the event of interrupted wireless connection.

### "HOLD" DIP switch

If the wireless connection is interrupted, the outputs of the I/O extension modules retain their last value or state.

### "RESET" DIP switch

If the wireless connection is interrupted, the outputs of the I/O extension modules are reset (output value is set to 0).

## 7.8 Saving the wireless network



**WARNING: Explosion hazard**

Do not insert or remove the CONFSTICK in a potentially explosive atmosphere!

Using a CONFSTICK (see accessories in the "Ordering data" section on page 3), you can configure a unique and secure network. This enables the parallel operation of multiple networks (using different RF bands).

Insert the CONFSTICK into the S-PORT of the wireless module. After accepting, the information is then loaded into the internal memory.



You have to configure each individual network device. To this end, you only need one CONFSTICK for all wireless modules in the network.

After configuration, you can remove the CONFSTICK from the wireless module.

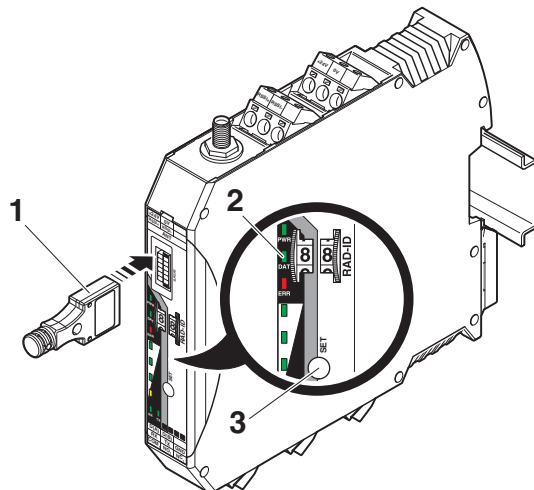

Figure 15 Configuration via CONFSTICK

- 1 CONFSTICK RAD-CONF-RF...
- 2 Status LEDs
- 3 SET button

The CONFSTICK contains: RF band (3, 5 or 7) and a unique network ID

The CONFSTICK is used as a network key.

### Reading in the device configuration using the CONFSTICK

- Insert the CONFSTICK into the S-PORT of the wireless module.
- Press and hold down the SET button on the wireless module for one second.
- Parameter read in is started.
- Read-in has been completed when the DAT LED lights up once. The new parameters are activated.
- Remove the CONFSTICK from the wireless module.

## 7.9 Copying device settings to new network devices

Your individual configuration data can be saved to a memory stick (RAD-MEMORY, see accessories in the "Ordering data" section on page 3), e.g., to transfer the same configuration to other devices.



### **WARNING: Explosion hazard**

Do not insert or remove the memory stick in a potentially explosive atmosphere.

### **Common network parameters:**

- Operating mode
- Network ID
- RF band
- Data rate of the wireless interface
- Encryption
- Network type

### **Individual device parameters:**

- Station name
- RAD ID
- Transmission power
- List of permitted connections
- Receive preamplifier ON/OFF
- Serial interface parameters

### **Writing a full copy of the individual device parameters and common network parameters to the memory stick (RAD-MEMORY):**



If an error is detected while saving or subsequently checking the data, the DAT and ERR LEDs flash simultaneously.

- Press and hold down the SET button on the wireless module for at least six seconds.
- The four RSSI bar graph LEDs start a light sequence from bottom to top.
- Insert the memory stick into the S port of the wireless module.
- The copying of parameters is started automatically.
- Wait until the RSSI bar graph LEDs reach the static state or the light sequence stops.  
The write process has been completed.
- Remove the memory stick from the wireless module.

### **Reading in common network parameters via the memory stick:**

This function enables common network parameters to be read in from the memory stick. This means that all network devices can have the same network parameters.

- Insert the memory stick into the S port of the wireless module.
- Press and hold down the SET button on the wireless module for one second.
- Parameter read in is started.
- Read-in has been completed when the DAT LED lights up once. The new parameters are activated.
- Remove the memory stick from the wireless module.

### **Reading in a full copy of the individual device parameters and common network parameters via the memory stick:**

This function enables all individual device parameters and common network parameters to be read in from the memory stick. This means that a full copy of devices can be created. This can be used, for example, to create a backup copy of a device for device replacement.

- Insert the memory stick into the S port of the wireless module.
- Press and hold down the SET button on the wireless module for at least six seconds.
- Parameter read in is started, the DAT LED flashes.
- Wait until the DAT LED is no longer flashing. The read-in has been completed. The new parameters are activated.
- Remove the memory stick from the wireless module.

## 8 Application examples

### Point-to-point connections

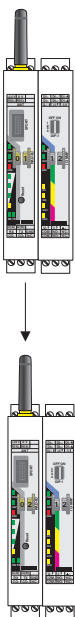

Figure 16 Example of point-to-point connection

### Mesh network

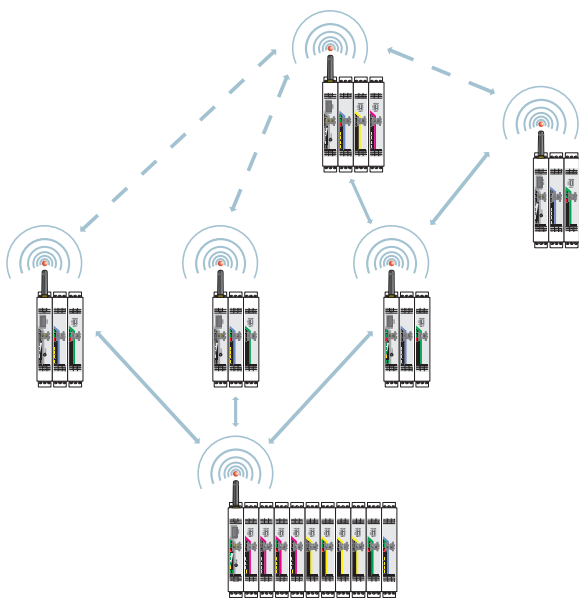

Figure 17 Example of mesh network

### Star network

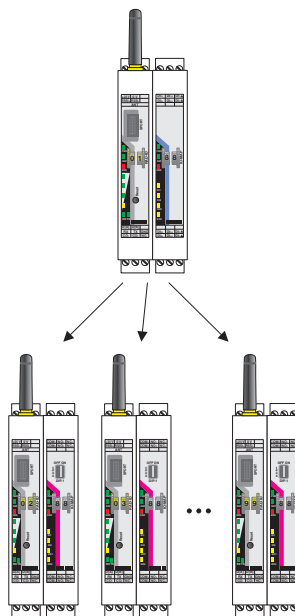

Figure 18 Example of multipoint-to-point connection

### I/O-to-I/O, wireless, and RS-485

You can connect Radioline RS-485 stations to a Radioline wireless master and thereby extend the wireless network. All devices in the wireless network and in the RS-485 network form one system. All stations are addressed uniquely using the yellow thumbwheel.

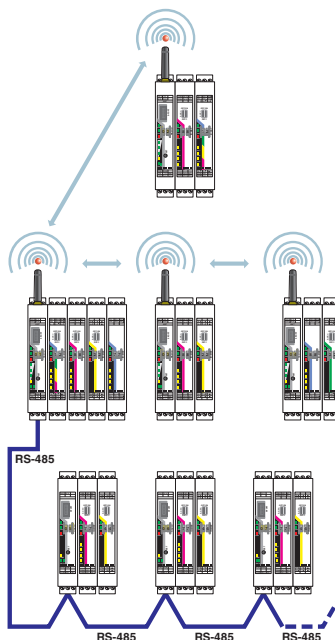

Figure 19 I/O-to-I/O, wireless, and RS-485

## 9 Process data

You can read the RSSI values (signal strength received) via the serial interface of the master wireless module by Modbus/RTU commands.

The RSSI values of all wireless modules are within the address area 35001 ... 35250.

### RSSI signal and error code register

Address space		35001 ... 35250																
Modbus function code		fc04																
Address	Wireless module	High byte								Low byte, RSSI values								
		15	14	13	12	11	10	09	08	07	06	05	04	03	02	01	00	
35001	RSSI - RAD ID = 1 (master)	Reserved								IFS	X	X	X	X	X	X	X	X
35002	RSSI - RAD ID = 2	Reserved									X	X	X	X	X	X	X	X
...	...	Reserved									X	X	X	X	X	X	X	X
35250	RSSI - RAD ID = 250	Reserved									X	X	X	X	X	X	X	X

Bit 08 = error on IFS bus

If an error occurs on the IFS bus, the register value = 1 (e.g., local bus error, as the input or output module is separated from the DIN rail connector).

If no errors are present on the IFS bus, the register value = 0.

- Bits 9 ... 15 are reserved.
- Values < 255 indicate the RSSI value in -dBm.
- The value 255 means that the RSSI value is invalid or the device cannot be reached.



# SCATTERGOOD & JOHNSON LTD

ELECTRICAL ENGINEERING & FLUID CONTROL DISTRIBUTORS

Est.1899

At Scattergood & Johnson Ltd, we pride ourselves on being a technical distributor to specialist industries.

Working with a range of quality product suppliers across a number of specialist markets, we are not your average 'box shifter' - we are your technical and supply chain partner.

We fully support every product we sell - for free! Our internal team and external sales engineers can answer any product or application question, no matter the complexity.

Backing up this technical ability is a range of 50,000+ products available from stock for nationwide next day delivery (same day if required!), or you can collect what you need from any of our trade counters around the UK.

Select your specialist interest below to learn more about how we can help.

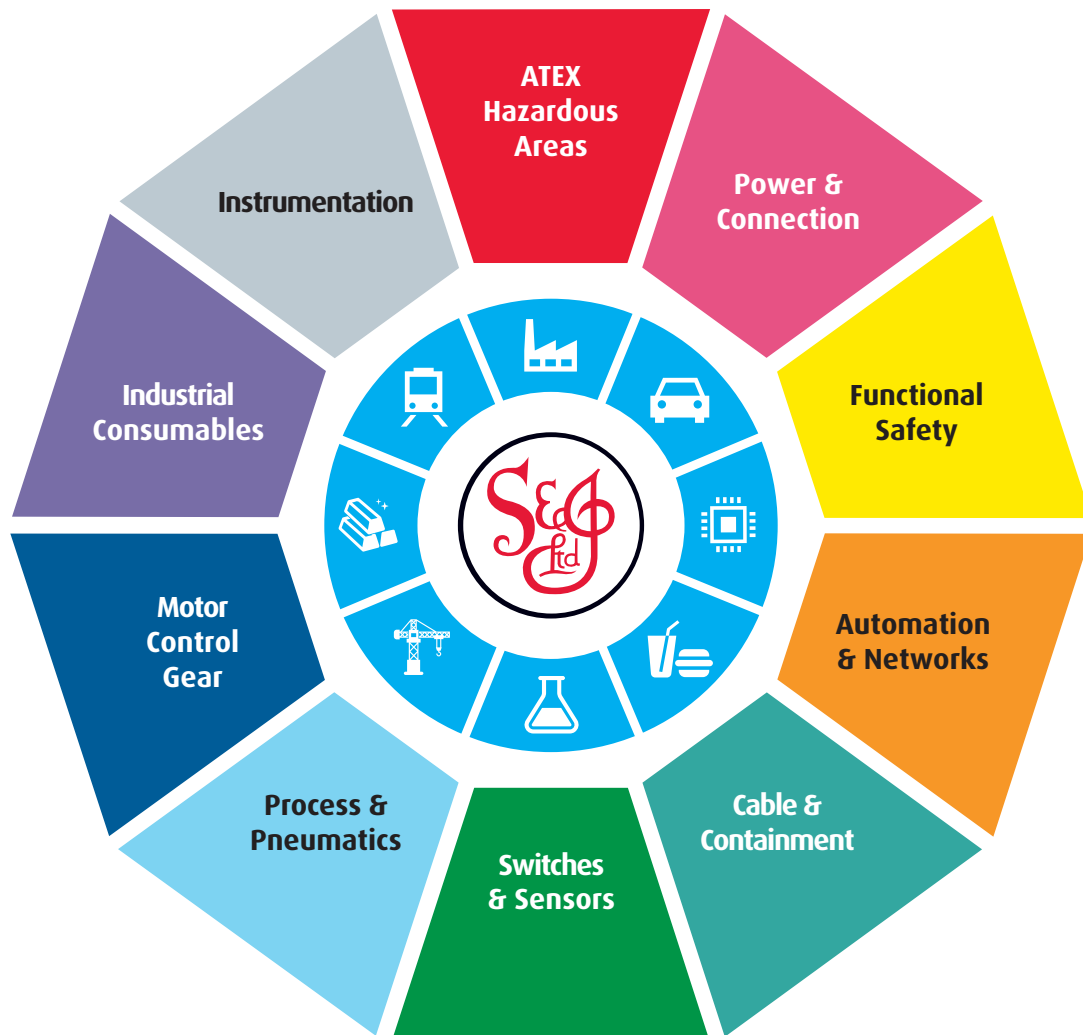

Online, In Branch and On the Road - Scattergood & Johnson Ltd, there when you need us.

# [www.scatts.co.uk](http://www.scatts.co.uk)