

FL MC EF 1300 MM ST





FO converter with B-FOC (ST[®]) connection (1300 nm), for converting 10/100Base-T(X) to multi-mode fiberglass

Data sheet
104914_en_04

© PHOENIX CONTACT 2019-03-14

1 Description

The **FL MC EF 1300 MM ST** FO converter provides a high level of immunity to interference and a long transmission range in industrial applications by converting the 10/100Base-T(X) Ethernet interface to fiber optics (100 Mbps according to FX standard).

If longer distances are to be covered or if an existing fiberglass installation is used, the FO converter covers distances of up to 10,000 m with 62.5/125 μm or 6400 m with 50/125 μm multi-mode fiberglass in full duplex mode.

Features

- 10/100Base-T(X) auto negotiation
- Auto MDI/MDIX switchover
- Operating mode and speed can be set manually
- Link fault pass through (LFPT)
- Far End Fault signaling (FEF)
- B-FOC (ST[®]) connection
- Mounting on a 35 mm DIN rail
- Redundant power supply possible
- Shipbuilding approval according to DNV GL



WARNING: Explosion hazard when used in potentially explosive areas

The device is a category 3 item of electrical equipment. Follow the instructions provided here during installation and observe the safety notes.



Make sure you always use the latest documentation.

It can be downloaded at: phoenixcontact.net/product/2902854

2	Table of contents	
1	Description	1
2	Table of contents	2
3	Ordering data	3
4	Technical data	5
5	Safety regulations and installation notes.....	8
	5.1 Installation notes	8
	5.2 Installation in Zone 2.....	8
6	Product description.....	10
	6.1 Dimensions	10
	6.2 Block diagram.....	10
	6.3 Function elements	11
	6.4 Diagnostics and status indicators.....	11
7	Transport and unpacking	11
8	Configuration via DIP switches	12
	8.1 Setting data transmission (DIP 1, DIP 2, and DIP 3).....	12
	8.2 Pause frame (DIP 4)	13
	8.3 Link fault pass through (DIP 6)	13
9	Installation	14
	9.1 Mounting on a DIN rail	14
	9.2 Combined mounting	14
	9.3 Removal.....	14
	9.4 Power supply voltage.....	15
10	Twisted pair interface (TP port).....	15
11	Fiber optic interface (FO port).....	16
12	Error localization.....	17
	12.1 Normal operation	17
	12.2 Fault on the copper cable	17
	12.3 Fault on the fiber optic cable.....	18
13	Disposal.....	18

3 Ordering data

Description	Type	Order No.	Pcs./Pkt.
FO converter with B-FOC (ST®) fiber optic connection (1300 nm), for converting 10/100Base-T(X) to multi-mode fiberglass (50/125 µm). Auto negotiation and auto MDI(X) function. Comprehensive link diagnostics. DIN-rail mountable, 18 ... 30 V DC supply.	FL MC EF 1300 MM ST	2902854	1
Accessories	Type	Order No.	Pcs./Pkt.
RJ45 connector, shielded, with bend protection sleeve, 2 pieces, gray for straight cables, for assembly on site. For connections that are not crossed, it is recommended that you use the connector set with gray bend protection sleeve. RJ45 connector, material: polycarbonate, color: gray	FL PLUG RJ45 GR/2	2744856	1
RJ45 connector, shielded, with bend protection sleeve, 2 pieces, green for crossed cables, for assembly on site. For connections that are crossed, it is recommended that the connector set with green bend protection sleeves is used. RJ45 connector, material: polycarbonate, color: green	FL PLUG RJ45 GN/2	2744571	1
CAT5-SF/UTP cable (J-02YS(ST)C HP 2 x 2 x 24 AWG), heavy-duty installation cable, 2 x 2 x 0.22 mm ² , solid conductor, shielded, outer sheath: 7.8 mm diameter, inner sheath: 5.75 mm ±0.15 mm diameter cable, Ethernet CAT5 (100 Mbps), 4-position, halogen-free compound, HM 2 in acc. with VDE 0207, water blue RAL 5021, cable length: Free input (0.25 ... 1000.0 m)	FL CAT5 HEAVY	2744814	1
CAT5-SF/UTP cable (J-LI02YS(ST)C H 2 x 2 x 26 AWG), light-duty, flexible installation cable 2 x 2 x 0.14 mm ² , stranded, shielded, outer sheath: 5.75 mm ±0.15 mm diameter	FL CAT5 FLEX	2744830	1
Crimping pliers, for assembling the RJ45 plugs FL PLUG RJ45..., for assembly on site	FL CRIMPTOOL	2744869	1
DIN rail connector, nominal current (Ex): 8 A, nominal voltage (Ex): 125 V, number of positions: 5, pitch: 3.81 mm, articles with gold-plated contacts, bus connectors for connecting with electronic housings	ME 22,5 TBUS 1,5/ 5-ST-3,81 GN	2707437	50
Primary-switched power supply unit, MINI POWER, pluggable screw connection, DIN rail mounting, output: 24 V DC / 1.5 A	MINI-SYS-PS-100-240AC/ 24DC/1.5	2866983	1
DIN rail connector for DIN rail mounting. Universal for TBUS housing. Gold-plated contacts, 5-pos. DIN rail connector, number of positions: 5, pitch: 3.81 mm, articles with gold-plated contacts, bus connectors for connecting with electronic housings	ME 17,5 TBUS 1,5/ 5-ST-3,81 GN	2709561	10

FL MC EF 1300 MM ST

Accessories	Type	Order No.	Pcs./Pkt.
Assembled FO cable, break out cable, multimode fiberglass 50/125 µm (OM2), connector: LC/B-FOC(ST®), degree of protection: IP20, for installation in cable ducts or control cabinets, length: 1 m	FL MM PATCH 1,0 LC-ST	2989174	1
Assembled FO cable, break out cable, multimode fiberglass 50/125 µm (OM2), connector: LC/B-FOC(ST®), degree of protection: IP20, for installation in cable ducts or control cabinets, length: 2 m	FL MM PATCH 2,0 LC-ST	2989271	1
Assembled FO cable, break out cable, multimode fiberglass 50/125 µm (OM2), connector: LC/B-FOC(ST®), degree of protection: IP20, for installation in cable ducts or control cabinets, length: 5 m	FL MM PATCH 5,0 LC-ST	2901801	1
Assembled FO cable, break out cable, multimode fiberglass 50/125 µm (OM2), connector: SC duplex/B-FOC(ST®), degree of protection: IP20, for installation in cable ducts or control cabinets, length: 1 m	FL MM PATCH 1,0 SC-ST	2901809	1
Assembled FO cable, break out cable, multimode fiberglass 50/125 µm (OM2), connector: SC duplex/B-FOC(ST®), degree of protection: IP20, for installation in cable ducts or control cabinets, length: 2 m	FL MM PATCH 2,0 SC-ST	2901810	1
Assembled FO cable, break out cable, multimode fiberglass 50/125 µm (OM2), connector: SC duplex/B-FOC(ST®), degree of protection: IP20, for installation in cable ducts or control cabinets, length: 5 m	FL MM PATCH 5,0 SC-ST	2901811	1
Assembled FO cable, break out cable, multimode fiberglass 50/125 µm (OM2), connector: B-FOC(ST®)/B-FOC(ST®), degree of protection: IP20, for installation in cable ducts or control cabinets, length: 1 m	FL MM PATCH 1,0 ST-ST	2901815	1
Assembled FO cable, break out cable, multimode fiberglass 50/125 µm (OM2), connector: B-FOC(ST®)/B-FOC(ST®), degree of protection: IP20, for installation in cable ducts or control cabinets, length: 2 m	FL MM PATCH 2,0 ST-ST	2901816	1
Assembled FO cable, break out cable, multimode fiberglass 50/125 µm (OM2), connector: B-FOC(ST®)/B-FOC(ST®), degree of protection: IP20, for installation in cable ducts or control cabinets, length: 5 m	FL MM PATCH 5,0 ST-ST	2901817	1
PROFINET HCS GI fiber cables, duplex 200/230 µm, increased bandwidth for Ethernet applications in particular. Robust PUR outer sheath. Heavy version suitable for drag chains and indoor installation, sold by the meter without plugs	FL FOC PN-C-HCS-GI-200/230	2313410	1
RJ45 connector, degree of protection: IP20, number of positions: 8, 1 Gbps, CAT5 (IEC 11801:2002), material: PA, connection method: IDC fast connection, connection cross section: AWG 26- 23, cable outlet: straight, color: traffic grey A RAL 7042	VS-08-RJ45-5-Q/IP20	1656725	1
B-FOC (ST) connector set for standard PROFINET PCF fiber cables with 2.2 mm diameter of the individual elements. Consisting of 4 quick mounting connectors with bend protection for self-assembly	PSM-SET-B-FOC/4-HCS/PN	2313782	1

4 Technical data

Supply

Supply voltage range	18 V DC ... 30 V DC (screw connection) 18 V DC ... 30 V DC (as an alternative or redundant, via backplane bus contact and system current supply)
Typical current consumption	< 100 mA (24 V DC)
Protective circuit	Reverse polarity protection
Electrical isolation	VCC // FE // Ethernet
Test voltage data interface/power supply	1.5 kV _{rms} (50 Hz, 1 min.)
Torque	0.56 Nm ... 0.79 Nm
Conductor cross section	0.20 mm ² ... 2.50 mm ² (24 AWG ... 14 AWG)

Ethernet interface, 10/100Base-T(X) in acc. with IEEE 802.3u

Number of ports	1
Connection method	RJ45 socket, shielded
Transmission speed	10/100 Mbps
Transmission length	100 m (shielded twisted pair)
Transmission medium	Copper
Auto-negotiation modes	Auto
Link through	Link fault pass through
MDI-/MDI-X switchover	Auto-MDI(X)
Signal LEDs	Activity, link status, 10/100 Mbps

FO interface

Data rate	100 Mbps
Connection method	B-FOC (ST [®])
Wavelength	1300 nm
Laser protection	Class 1 according to DIN EN 60825-1
Transmission length incl. 3 dB system reserve	6.4 km (with F-G 50/125 0,7 dB/km F 1000) 2.8 km (with F-G 50/125 1,6 dB/km F 800) 10 km (with F-G 62,5/125 0,7 dB/km F 1000) 3 km (with F-G 62.5/125 2.6 dB/km F 600)
Transmit capacity, minimum	≥ -23.5 dBm ((50/125 μm) dynamic in link mode (average)) ≥ -20 dBm ((62,5/125 μm) dynamic in link mode (average))
Transmit capacity, maximum	≤ -14 dBm ((50/125 μm) dynamic in link mode (average)) ≤ -14 dBm ((62,5/125 μm) dynamic in link mode (average))
Minimum receiver sensitivity	-31 dBm (dynamic in link mode (average))
Overrange receiver	-14 dBm (dynamic in link mode (average))
Signal LEDs	Far end fault (red LED), link status (yellow LED)

General data	
Basic functions	Store-and-forward media converter
Degree of protection	IP20
Dimensions (W/H/D)	22.5 mm x 99 mm x 114.5 mm
Housing material	PA 6.6-FR green
Free fall in acc. with IEC 60068-2-32	1 m
Vibration resistance in acc. with EN 60068-2-6/ IEC 60068-2-6	5g, 10...150 Hz, 2.5 h, in XYZ direction
Shock in acc. with EN 60068-2-27/IEC 60068-2-27	25g, 11 ms period, half-sine shock pulse
MTTF (mean time to failure) SN 29500 standard, temperature 25 °C, operating cycle 21 % (5 days a week, 8 hours a day)	1400 Years
MTTF (mean time to failure) SN 29500 standard, temperature 40 °C, operating cycle 34.25 % (5 days a week, 12 hours a day)	599 Years
MTTF (mean time to failure) SN 29500 standard, temperature 40 °C, operating cycle 100 % (7 days a week, 24 hours a day)	101 Years
Electromagnetic compatibility	Conformance with EMC Directive 2014/30/EU
Ambient conditions	
Ambient temperature (operation)	-40 °C ... 65 °C
Ambient temperature (storage/transport)	-40 °C ... 85 °C
Permissible humidity (operation)	30 % ... 95 % (non-condensing)
Permissible humidity (storage/transport)	30 % ... 95 % (non-condensing)
Altitude	5000 m (for restrictions see manufacturer's declaration) 2000 m (with UL approval)
Approvals / Certificates	
Conformance	CE-compliant EAC
Free from substances that could impair the application of coating	according to P-VW 3.10.7 57 65 0 VW-AUDI-Seat central standard
ATEX Please follow the special installation instructions in the documentation!	⊕ II 3 G Ex nA IIC T4 Gc X ⊕ II (2) D [Ex op is Db] IIIC (PTB 06 ATEX 2042 U) ⊕ II (2) G [Ex op is Gb] IIC (PTB 06 ATEX 2042 U)
UL, USA/Canada	cULus listed UL 508 Class I, Zone 2, AEx nA IIC T4 Class I, Zone 2, Ex nA IIC T4 Gc X Class I, Div. 2, Groups A, B, C, D
Standards/regulations	EN 60950-1
Noxious gas test	ISA-S71.04-1985 G3 Harsh Group A

Approvals / Certificates

Shipbuilding approval	DNV GL
DNV GL, Temperature	B
DNV GL, Humidity	A
DNV GL, Vibration	A
DNV GL, EMC	B
DNV GL, Enclosure	Required protection according to the Rules shall be provided upon installation on board

Conformance with EMC Directive 2014/30/EU**Noise immunity according to EN 61000-6-2**

Electrostatic discharge	EN 61000-4-2
	Contact discharge ± 6 kV (Test Level 3)
	Discharge in air ± 8 kV (Test Level 3)
	Indirect discharge ± 6 kV
	Comments Criterion B
Electromagnetic HF field	EN 61000-4-3
	Frequency range 80 MHz ... 3 GHz (Test Level 3)
	Field intensity 10 V/m
	Comments Criterion A
Fast transients (burst)	EN 61000-4-4
	Input ± 2 kV (Test Level 3)
	Signal ± 2 kV (Test Level 3)
	Comments Criterion B
Surge current loads (surge)	EN 61000-4-5
	Input ± 0.5 kV (DC supply)
	Signal ± 1 kV (Data line, asymmetrical)
	Comments Criterion B
Conducted interference	EN 61000-4-6
	Frequency range 0.15 MHz ... 80 MHz
	Voltage 10 V
	Comments Criterion A

Emitted interference in acc. with EN 61000-6-4

Interference emission	EN 55032 Class A, industrial applications
-----------------------	--

Criterion A Normal operating behavior within the specified limits

Criterion B Temporary impairment of operating behavior that is corrected by the device itself

5 Safety regulations and installation notes

5.1 Installation notes



CAUTION:

Observe the following safety notes when using the device.

- The category 3 device is designed for installation in zone 2 potentially explosive areas. It meets the requirements of EN 60079-0:2012+A11:2013 and EN 60079-15:2010.
- Installation, operation, and maintenance may only be carried out by qualified electricians. Follow the installation instructions as described.
- When installing and operating the device, the applicable regulations and safety directives (including national safety directives), as well as general technical regulations, must be observed. The technical data is provided in the package slip and on the certificates (conformity assessment, additional approvals where applicable).
- The device must not be opened or modified apart from the configuration of the DIP switches. Do not repair the device yourself but replace it with an equivalent device. Repairs may only be carried out by the manufacturer. The manufacturer is not liable for damage resulting from a failure to comply.
- The IP20 protection (IEC 60529/EN 60529) of the device is intended for use in a clean and dry environment. The device must not be subject to mechanical strain and/or thermal loads, which exceed the limits described.
- The device is not designed for use in atmospheres with a danger of dust explosions.
- If dust is present, it is necessary to install into a suitable approved housing, whereby the surface temperature of the housing must be taken into consideration.

5.2 Installation in Zone 2



WARNING: Explosion hazard when used in potentially explosive areas

Please make sure that the following notes and instructions are observed.

- Observe the specified conditions for use in potentially explosive areas.
- The device should be installed so that a degree of protection of at least IP54 is achieved in accordance with EN 60529. To this end, a suitable, approved housing that meets the requirements of EN 60079-15 should be used.
- Only devices that are designed for operation in Ex Zone 2 and the conditions at the installation location may be connected to the circuits in Zone 2.
- In potentially explosive areas, terminals may only be snapped onto or off the DIN rail connector and wires may only be connected or disconnected when the power is switched off.
- The switches of the device that can be accessed may only be actuated when the power supply to the device is disconnected.
- The device must be stopped and immediately removed from the Ex area if it is damaged, was subject to an impermissible load, stored incorrectly or if it malfunctions.
- For reliable operation, the RJ45 plug needs to have a fully functioning locking clip. Repair any damaged plugs immediately.
- The FO components of type FL MC transmitter control are a part of the module. The fibre optics interface is used for optical communication with devices, which are used in the potentially explosive area of zone 1 or zone 21. It is used in accordance with the EC examination certificate PTB 06 ATEX 2042U.

UL note

**WARNING: Explosion hazard when used in potentially explosive areas**

Please make sure that the following notes and instructions are observed.

**INDUSTRIAL CONTROL EQUIPMENT 11AE**

Wire Range: 24-14 AWG

Torque: 5-7 (Lbs-In)

Environmental designation: "Open Type Device"

"Pollution Degree 2 Installation Environment"

PROCESS CONTROL EQUIPMENT FOR HAZARDOUS LOCATIONS 31ZN

- A) This equipment is suitable for use in Class I, Zone 2, AEx nA IIC T4; Ex nA IIC T4 Gc X or Class I, Division 2, Groups A, B, C, D or non-hazardous locations only.
- B) Provision shall be made to prevent transient disturbances of more than 140% of the rated supply voltage.
- C) The device must be installed in a Class I, Zone 2 certified overall enclosure rated IP54 with tool-accessible only cover or door and in degree of pollution 2 environment only.
- D) Unit shall be supplied by Limited Energy circuit according to clause 9.4 of UL 61010-1 3rd edition of Limited Power Source according to clause 2.5 of UL 60950-1 or NEC Class 2.
- E) Conductor temperature rating must be 72°C or higher.
- F) Maximum relative humidity 80 % for temperatures up to 31°C decreasing linearly to 50 % relative humidity at 40°C.

6 Product description

6.1 Dimensions

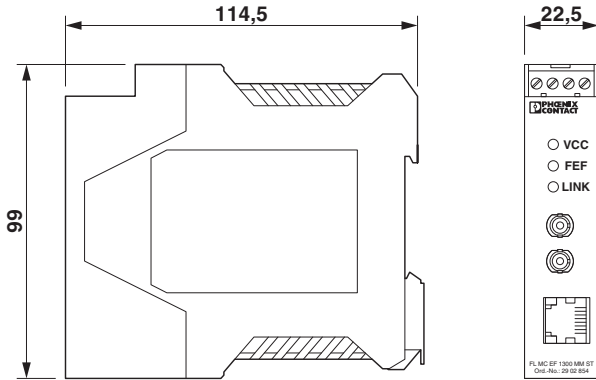

Figure 1 Housing dimensions

6.2 Block diagram

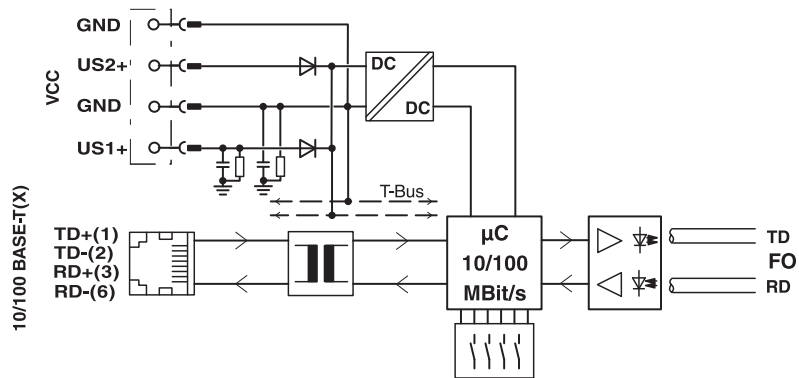

Figure 2 Block diagram

6.3 Function elements

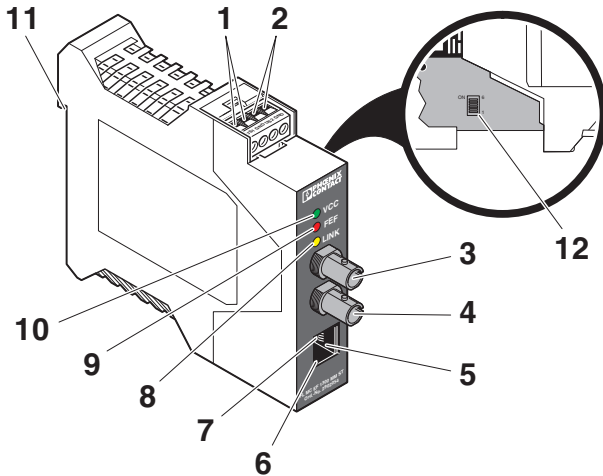

Figure 3 Function elements

- 1 24 V DC Supply voltage
- 2 24 V DC Supply voltage, redundant
- 3 Fiber optic (FO) receiver
- 4 Fiber optic (FO) transmitter
- 5 RJ45 Ethernet port, 10/100Base-T(X)
- 6 LED Link/Activity/10/100
- 7 LED HD/FD
- 8 LED LINK
- 9 LED FEF
- 10 LED VCC
- 11 Functional earth ground
- 12 DIP switch

6.4 Diagnostics and status indicators

Ethernet interface (TP port)

6	Link/Activity/10/100			
	Yellow	On		10 Mbps link
		Flashing		10 Mbps link - active data transmission
	Green	On		100 Mbps link
		Flashing		100 Mbps link - active data transmission
7	HD/FD	Green	Off	Half duplex transmission
			On	Full duplex transmission

Fiber optics interface (FO port)

8	LINK	Yellow	On	Fiber optics link available, no data communication
			Flashing	Data transmission at FO port
9	FEF	Red	On	Far end fault has occurred. Remote station reports: "no light".

Supply voltage

10	VCC	Green	On	Supply voltage OK
----	-----	-------	----	-------------------

Far End Fault signal (FEF)

If in the case of a FO converter the fiber optic connection for transmission fails, the FO converter on the opposite side sends the "No light" signal. This Far End Fault signal is received by the FO converter with the transmission fault via the receive cable and indicated with the red FEF LED.

If the copper connection is interrupted at one of the FO converters, data communication for both FO converters in both the optical and copper segment is disabled by the link fault pass through function. In this case, all Link LEDs go out. However, in order that error diagnostics can be carried out, the red FEF LED lights up on the FO converter where the copper segment is interrupted.

7 Transport and unpacking

- Check the delivery for visible damage caused by transportation.
- Submit claims for any transport damage immediately. Inform Phoenix Contact or your supplier as well as the shipping company without delay.
- Read the complete packing slip carefully.
- Retain the packing slip.
- Keep the packaging for a possible later transport.

8 Configuration via DIP switches



NOTE: electrostatic discharge!
 Electrostatic discharge can damage or destroy components.

- When handling the device, observe the necessary safety precautions against electrostatic discharge (ESD) according to EN 61340-5-1 and IEC 61340-5-1.



Only select the mode of operation when the power is disconnected! The change is activated after renewed power up.

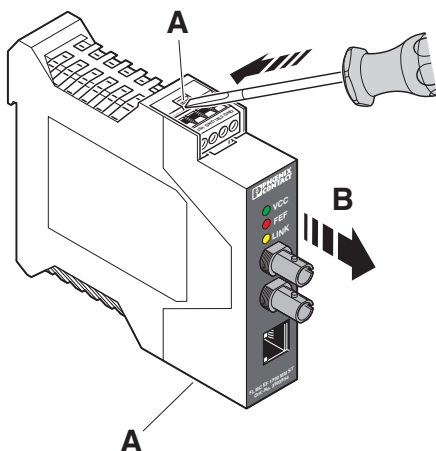

Figure 4 Opening the housing

- Disengage the housing cover with a screwdriver (A).
- Then carefully pull the PCB out of the housing as far as possible (B).

By default, all DIP switches are in the “OFF” position. The copper side of the device operates in “Auto negotiation” mode.

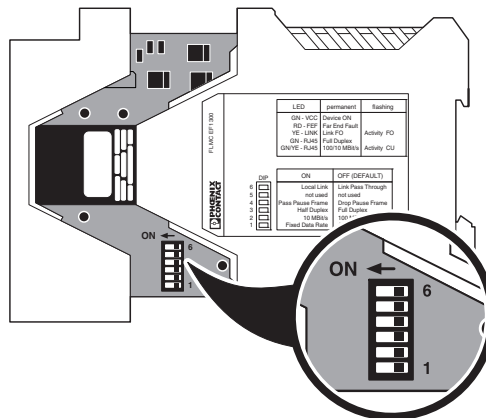

Figure 5 DIP switches

DIP	ON	OFF (default setting)
6	LFPT deactivated (local)	LFPT activated (global)
5	Not used	
4	Pass pause frame	Drop pause frame
3	Half duplex transmission	Full duplex transmission
2	10 Mbps	100 Mbps
1	Fixed transmission speed on the copper side	Auto negotiation

8.1 Setting data transmission (DIP 1, DIP 2, and DIP 3)

DIP 1 = OFF: the connected end devices negotiate 10/100 Mbps transmission speed and half/full transmission mode directly. The entire path behaves like a directly connected copper cable.

DIP 1 = ON: you set the transmission speed and mode manually with DIP switches 2 and 3.

- DIP 1 OFF Auto negotiation
- DIP 1 ON DIP 2 OFF 100 Mbps
- ON 10 Mbps
- DIP 3 OFF Full duplex transmission
- ON Half duplex transmission



If DIP switch 1 is in the “OFF” position, the position of DIP switch 2 and 3 is not queried.

8.2 Pause frame (DIP 4)

A pause frame signal can request an Ethernet device to temporarily interrupt data transmission. This avoids overloading the partner when, for example, communication takes place with different transmission speeds.

DIP 4 = OFF: the device does not respond to an incoming pause frame signal. It is also not forwarded. A pause frame signal cannot be generated by the device itself.

The transmission of pause frame signals is negotiated in sections.

DIP 4 = ON: the device responds to pause frame signals or forwards them. A pause frame signal can be generated by the device itself.

8.3 Link fault pass through (DIP 6)

The LFPT (link fault pass through) function provides permanent connection monitoring. The link on the fiber optic connection switches off if the connection is lost on the copper side of a FO converter. The FO converter on the other side registers the aborted link via the fiber optic path and likewise interrupts the connection for its twisted pair segment.

The entire connection over the optical path is therefore as transparent as it would be were communication purely copper-based. Both sides of the network connection can therefore detect a lost link immediately and respond accordingly. In the event of an error, this keeps the network load low and ensures that redundancy mechanisms can be activated.

DIP 6 = OFF: the LFPT function is activated. In the event of a fault, the entire connection is disabled (global).

DIP 6 = ON: the LFPT function is deactivated. In the event of a fault, only the interrupted segment is disabled (local). This is useful during startup and in the event of an error.

9 Installation



NOTE: device damage

Only mount and remove devices when the power supply is disconnected.



NOTE: Malfunction

Use a grounding terminal block to connect the DIN rail to protective earth ground. The devices are grounded when they are snapped onto the DIN rail (installation according to PELV). This ensures that the shielding is effective. Connect protective earth ground with low impedance.

The device is intended for installation in a control cabinet.

9.1 Mounting on a DIN rail

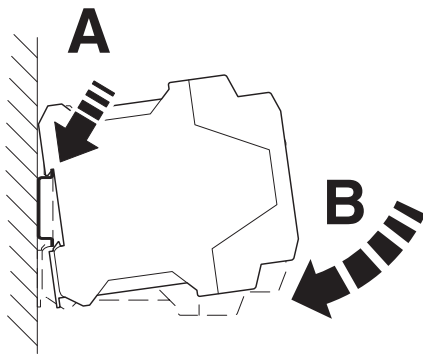

Figure 6 Mounting on a DIN rail

- To avoid contact resistance, only use clean, corrosion-free 35 mm DIN rails according to DIN EN 60715.
- Install an end bracket next to the left-hand device to prevent the devices from slipping.
- Place the device onto the DIN rail from above. Push the module from the front toward the mounting surface until it audibly engages.
- Snap the other devices that are to be contacted onto the DIN rail next to one another.

9.2 Combined mounting



A connection station must not consist of more than ten devices.

Observe the snap-in direction of the device and DIN rail connector: snap-on foot below and plug on the left.

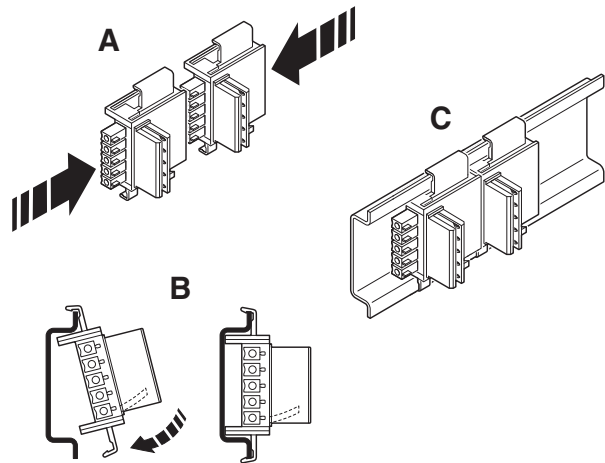

Figure 7 Combined assembly

The DIN rail connector bridges the supply voltage.

- Connect the DIN rail connectors (Order No. 2707437, 1 pc. per device) together for a connection station.
- Push the connected DIN rail connectors into the DIN rail.
- Place the device onto the DIN rail from above. Ensure the device and DIN rail connector are aligned correctly.
- Push the front of the device toward the mounting surface until it audibly snaps into place.

9.3 Removal

- Push down the locking tab with a screwdriver, needle-nose pliers or similar.
- Slightly pull the bottom edge of the device away from the mounting surface.
- Pull the device away from the DIN rail.

9.4 Power supply voltage



CAUTION: Electric shock

The device is only intended for operation with SELV according to IEC 60950/EN 60950/VDE 0805.

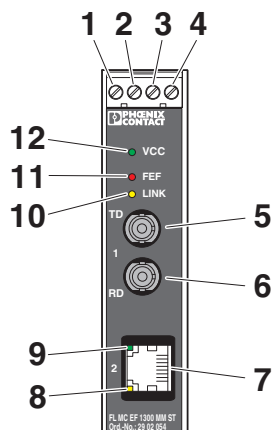

- | | | |
|---|---------|---------------------------|
| 1 | 24 V DC | Supply voltage |
| 2 | 0 V DC | Supply voltage |
| 3 | 24 V DC | Supply voltage, redundant |
| 4 | 0 V DC | Supply voltage, redundant |

Operation as a single device

- Supply voltage to the device via terminal blocks 1 (24 V) and 2 (0 V).
- Optional: for a redundant power supply, connect an additional power supply unit to terminal blocks 3 and 4.

Combined operation with a system power supply

When mounting the media converter on the DIN rail connector, please observe section "9.2 Combined mounting".

- Connect a system power supply to two DIN rail connectors on the left of the group.
 - MINI-SYS-PS-100-240AC/24DC/1.5, Order No. 2866983 or
 - MINI-PS100-240AC/24DC/1.5/EX, Order No.: 2866653
 - Two DIN rail connectors, Order No. 2709561
- A second power supply unit can be used to create a redundant supply concept.

10 Twisted pair interface (TP port)



NOTE: Interference

Only use shielded twisted pair cables and corresponding shielded RJ45 connectors.

- Only twisted pair cables with an impedance of 100 Ω can be connected to the RJ45 Ethernet interface.

The data transmission speed is 10/100 Mbps

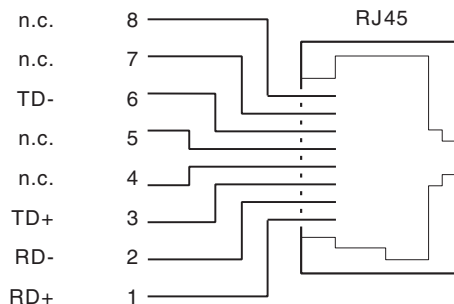

Figure 8 Pin assignment

- Insert the Ethernet cable with the RJ45 plug into the TP interface until the plug engages audibly. Observe the plug keying.

11 Fiber optic interface (FO port)



WARNING: Risk of eye injury
 The light can cause damage to eyes.
 During operation, do not look directly into transmitter diodes or use visual aids to look into the glass fibers. The infrared light is not visible.



Avoid contamination.
 Remove the dust protection caps just before the connectors are connected!



When using fiber optics, observe the fiber optic installation guidelines, DB GB IBS SYS FOC ASSEMBLY, Order No. 9423439.

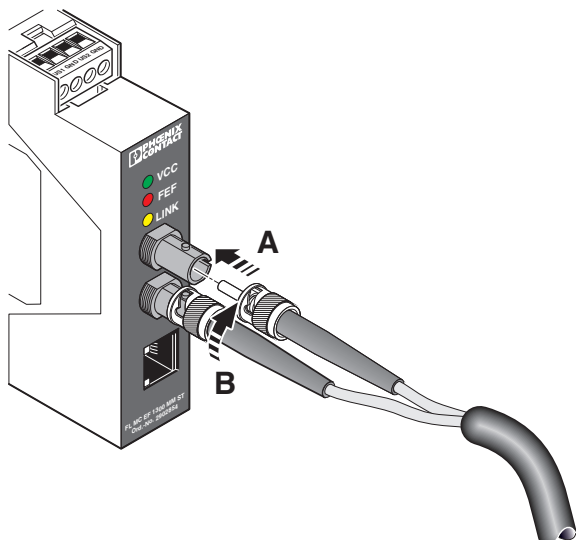

Figure 9 Connect B-FOC (ST[®]) plug

- Remove the dust protection cap.
- Connect the fiber optic cable to the B-FOC (ST[®]) connector for the transmit and receive channel. Make sure the coding is in the correct position.
- Push the connector spring mechanism downwards.
- Secure the connection with a quarter turn to the right (B).

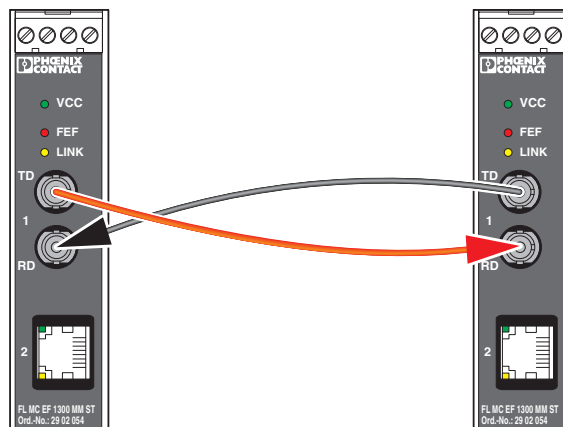

Figure 10 Signal direction for the fiber connection

When connecting two FO converters, note the signal direction of the fiber optics.

- Fiber connection “TD” (transmitter) at device 1
- Fiber connection “RD” (receiver) at device 2

Please note the transmit and receive channel crossover.

12 Error localization

12.1 Normal operation

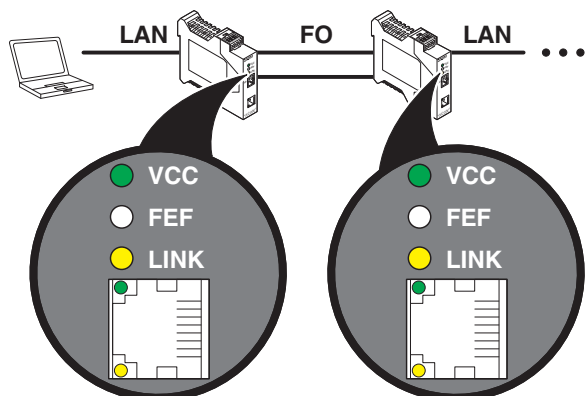

Figure 11 Diagnostics indicators in normal operation

12.2 Fault on the copper cable

The diagnostics indicator depends on DIP 6.

LFPT activated, global (DIP 6 = OFF, default setting)

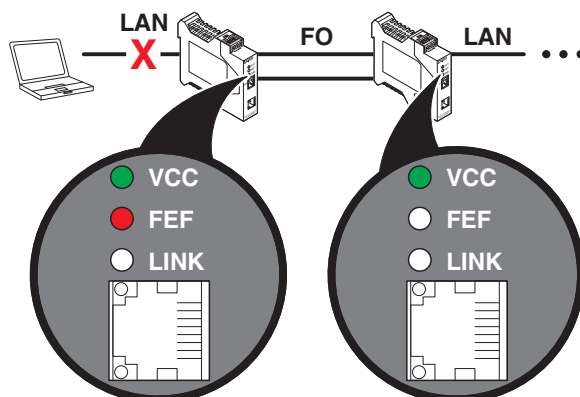

Figure 12 LAN fault with LFPT activated, global

DIP 6 = OFF: by default, all Link LEDs go out in the event of a fault in a twisted pair segment.

The red FEF LED indicates the FO converter where the twisted pair segment failed.

LFPT deactivated, local (DIP 6 = ON)

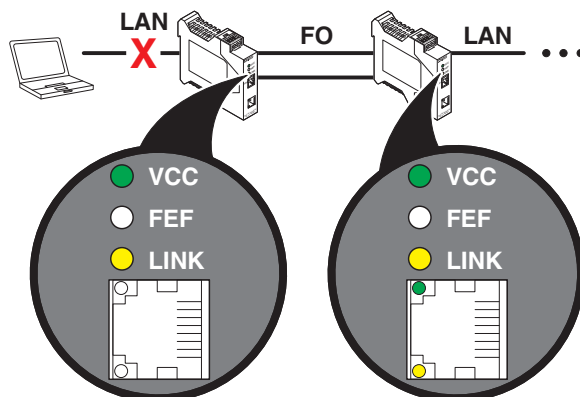

Figure 13 LAN fault with LFPT deactivated, local

DIP 6 = ON: in the “LFPT deactivated, local” setting, only the Link LEDs of the corresponding port go out in the event of a fault in a twisted pair segment. The Link LEDs at the copper port on the other media converter and for the fiber optic connection are on. The “LFPT deactivated, local” setting therefore enables more precise diagnostics.

12.3 Fault on the fiber optic cable

The diagnostics indicator depends on DIP 6.

LFPT activated, global (DIP 6 = OFF, default setting)

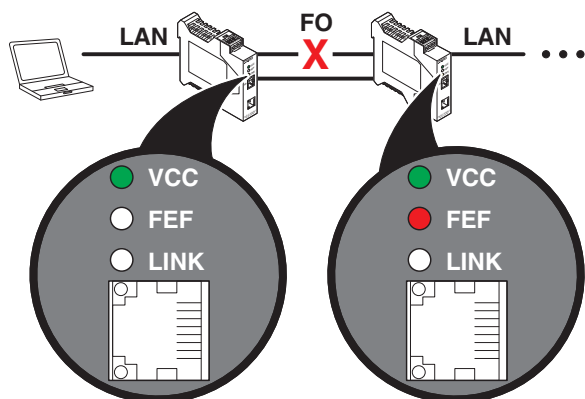

Figure 14 Fiber optic fault with LFPT activated, global

If just one of the optical fibers is interrupted, you can determine which is the affected fiber via the FEF LEDs. If the FEF LED at a media converter lights up, the fiber connected to the transmit port (TD) is interrupted. The entire connection is disabled.

LFPT deactivated, local (DIP 6 = ON)

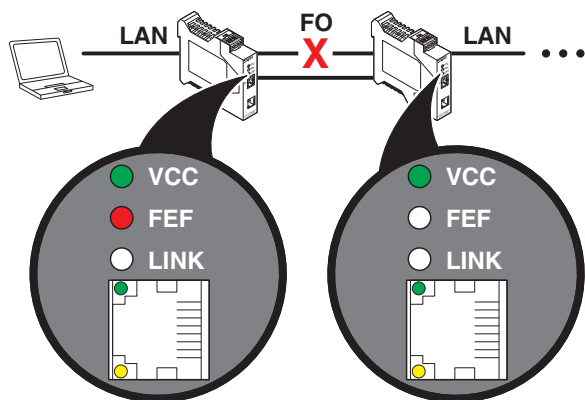

Figure 15 Fiber optic fault with LFPT deactivated, local

The red FEF LED lights up if the optical fiber at the transmit port of the device is interrupted. Only the affected segment is disabled, the copper port connections remain.

13 Disposal



Dispose of the device separately from other waste, i.e., via an appropriate collection site.



SCATTERGOOD & JOHNSON LTD

ELECTRICAL ENGINEERING & FLUID CONTROL DISTRIBUTORS

Est.1899

At Scattergood & Johnson Ltd, we pride ourselves on being a technical distributor to specialist industries.

Working with a range of quality product suppliers across a number of specialist markets, we are not your average 'box shifter' - we are your technical and supply chain partner.

We fully support every product we sell - for free! Our internal team and external sales engineers can answer any product or application question, no matter the complexity.

Backing up this technical ability is a range of 50,000+ products available from stock for nationwide next day delivery (same day if required!), or you can collect what you need from any of our trade counters around the UK.

Select your specialist interest below to learn more about how we can help.



Online, In Branch and On the Road - Scattergood & Johnson Ltd, there when you need us.

www.scatts.co.uk