

TC ANT MOBILE...

Mobile antennas and antenna cables





Data sheet
106760_en_04

© PHOENIX CONTACT 2019-06-05



1 Description

This data sheet describes the accessories for mobile communications products. All mobile communications products from Phoenix Contact have an SMA antenna connection. Therefore, you can use the following antennas:

Designation	Order No.	Mounting	Image
PSI-GSM-STUB-ANT	2313342	Mounting directly on device, installation not visible from the outside in plastic control cabinets	
TC ANT MOBILE WALL 5M	2702273	Wall or mast mounting with mounting bracket, indoor or outdoor installation, suitable for LTE/4G	
TC ANT MOBILE WALL 0,5M	2702274	Wall mounting with mounting bracket, indoor or outdoor installation, suitable for LTE/4G	
PSI-GSM/UMTS-QB-ANT	2313371	Mounting on the control cabinet, with 2 m antenna cable	
TC ANT MOBILE/GPS	2903590		
TC ANT MOBILE CABINET 10M	1046361		

Furthermore, antenna cables are also available for extending by 5 meters or 10 meters.



Make sure you always use the latest documentation. It can be downloaded at phoenixcontact.net/products.

2 Table of contents

1	Description.....	1
2	Table of contents	2
3	Ordering data.....	3
4	PSI-GSM-STUB-ANT	4
	4.1 Dimensions	4
	4.2 Mounting	4
5	TC ANT MOBILE WALL 5M and TC ANT MOBILE WALL 0,5M	5
	5.1 Safety notes	6
	5.2 Mounting with mounting bracket.....	6
	5.3 Mounting on a surface	7
	5.4 Laying the antenna cable	7
6	PSI-GSM/UMTS-QB-ANT and TC ANT MOBILE/GPS	8
	6.1 Mounting	9
7	TC ANT MOBILE CABINET 10M	10
	7.1 Dimensions	10
	7.2 Mounting	11
8	Antenna cables	12

3 Ordering data

Antennas	Type	Order No.	Pcs./Pkt.
GSM antenna for direct mounting on the device, angled antenna plug (90°, SMA circular connector). The antenna is suitable for installation not visible from the outside in plastic control cabinets.	PSI-GSM-STUB-ANT	2313342	1
Multiband mobile antenna with mounting bracket for outdoor installation, 5 m antenna cable with SMA circular connector, suitable for LTE/4G	TC ANT MOBILE WALL 5M	2702273	1
Multiband mobile antenna for wall mounting, 0.5 m antenna cable, with SMA circular connector, suitable for LTE/4G	TC ANT MOBILE WALL 0,5 M	2702274	1
GSM-UMTS antenna, with omnidirectional characteristics, 2 m antenna cable with SMA circular connector, for mounting on the control cabinet	PSI-GSM/UMTS-QB-ANT	2313371	1
Combined mobile GPS antenna with omnidirectional characteristics, 2 m antenna cable with SMA circular connector (GSM/UMTS) and R-SMA circular connector (GPS) for mounting on the control cabinet	TC ANT MOBILE/GPS	2903590	1
Mobile antenna for mounting on the control cabinet, 10 m antenna cable with SMA circular connector	TC ANT MOBILE CABINET 10M	1046361	1
Antenna cables	Type	Order No.	Pcs./Pkt.
Mobile antenna cable, 5 m in length, SMA (male) -> SMA (female), 50 ohm impedance	PSI-CAB-GSM/UMTS- 5M	2900980	1
Mobile antenna cable, 10 m in length, SMA (male) -> SMA (female), 50 ohm impedance	PSI-CAB-GSM/UMTS-10M	2900981	1

4 PSI-GSM-STUB-ANT

The antenna is suitable for installation not visible from the outside in plastic control cabinets.

PSI-GSM-STUB-ANT	2313342
Frequency range	900 MHz / 1800 MHz
Standing wave ratio (VSWR in a 50 ohm system)	Typical <2.0
Gain	Typical 0 dB
Polarization	Vertical
General data	
Function	GSM omnidirectional antenna
Ambient temperature range	-40°C ... 105°C
Connection	SMA circular connector, angled at 90°
Dimensions	
Height	85.7 mm
Diameter	10 mm

4.1 Dimensions

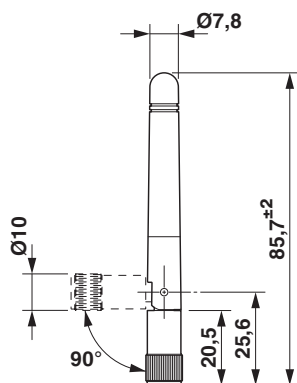

Figure 1 Dimensions

4.2 Mounting



Figure 2 Antenna for mounting directly on the device



When installing in a control cabinet, reception may be strongly impaired. Interference-free operation is not guaranteed.

- Use a GSM antenna with connecting cable (e.g., 2313371, PSI-GSM/UMTS-QB-ANT) and mount it outside the control cabinet.

5 TC ANT MOBILE WALL 5M and TC ANT MOBILE WALL 0,5M

	TC ANT MOBILE WALL 5M 2702273	TC ANT MOBILE WALL 0,5M 2702274
Frequency range	700 MHz / 800 MHz / 850 MHz / 900 MHz / 1700 MHz / 1800 MHz / 1900 MHz / 2100 MHz / 2600 MHz / 3600 MHz	
Standing wave ratio (VSWR in a 50 ohm system)	<2.50	
Gain (depending on frequency and connection assembly)		
698 ... 960 MHz	3 dBi	3 dBi
1710 ... 2700 MHz	5 dBi	5 dBi
3400 ... 3800 MHz	8 dBi	5 dBi
Power, maximum	30 W	
Polarization	Vertical	
General data		
Function	Multiband mobile antenna with omnidirectional characteristics	
Ambient temperature range	-40°C ... 80°C	-40°C ... 85°C
Connection	5 m antenna cable with SMA circular connector	0.5 m antenna cable with SMA circular connector
Dimensions		
Height	82 mm	
Diameter	48 mm	
Antenna housing material	ASA	ASA, aluminum, galvanized steel
Degree of protection	IP65	IP66
Mounting type	Wall mounting or mast mounting, indoor or outdoor installation	Wall mounting, indoor or outdoor instal- lation



Figure 3 TC ANT MOBILE WALL 5M



Figure 4 TC ANT MOBILE WALL 0,5M

5.1 Safety notes



WARNING: Risk of death due to electric shock

Parts of the antenna are electrically conductive. Contact with live cables can lead to death or serious injuries.

- The antenna and the mast must not be in the vicinity of live cables during installation or removal.
- If there is risk of lightning strikes: Make sure that the antenna is mounted and grounded by qualified specialist personnel in accordance with generally recognized technical regulations.



WARNING: Fall hazard

Make sure that the mounting location can be reached safely with the available equipment.



CAUTION: High frequency

Mount the antenna in such a way that persons will not be within a radius of 30 centimeters during operation.

5.2 Mounting with mounting bracket

Selecting the mounting location

With the mounting bracket, you can mount the antenna onto a wall. Alternatively, you can also mount the TC ANT MOBILE WALL 5M to a mast.

Mount the antenna vertically with the antenna cable facing downwards. Note that there must be a gap of at least 30 centimeters between the antenna and metallic parts or surfaces. Select the mounting location so that the antenna cable can be routed safely to the device.

If you use screws, make sure that there is sufficient space behind the mounting area. Only use the mounting bracket supplied. Other brackets could impair the performance of the antenna.

Select an antenna position providing good wireless network conditions.

If you use two antennas on a 4G mobile communications device (MIMO), allow at least 20 centimeters distance between the antennas. This way, you will achieve optimum reception.

TC ANT MOBILE WALL 5M, wall or mast mounting

- **Wall mounting:** Mount the mounting bracket. Use M5 machine screws or self-tapping screws. You can use the bracket as a drilling template (see Figure 5).
- **Mast mounting:** Mount the mounting bracket using a worm drive clip with a maximum width of 14 mm (see Figure 6).
- If you wish to mount the antenna permanently, you **can also** use the adhesive surface on the bottom side of the antenna. In this case, make sure that the surface of the bracket is clean and dry. Pull the foil off the adhesive surface. Press the antenna firmly onto the bracket.
- Fix the antenna firmly to the mounting bracket using the nut and washer supplied.

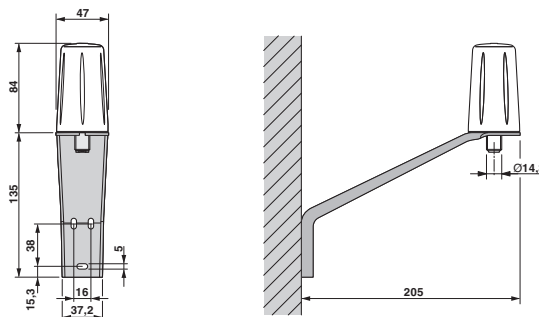

Figure 5 TC ANT MOBILE WALL 5M, wall mounting

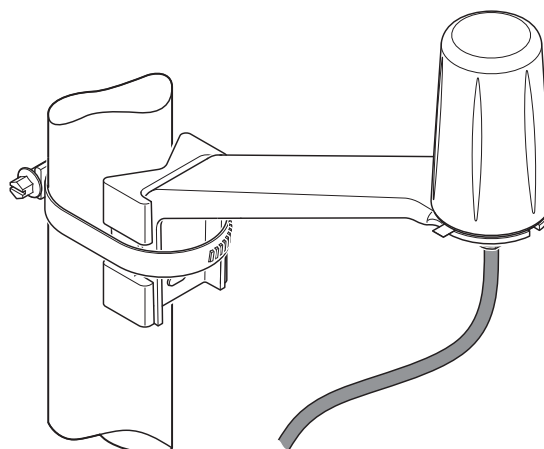

Figure 6 TC ANT MOBILE WALL 5M, mast mounting

TC ANT MOBILE WALL 0,5M, wall mounting

- Mount the mounting bracket. Use M5 machine screws or self-tapping screws. You can use the bracket as a drilling template.
- If you wish to mount the antenna permanently, you **can also** use the adhesive surface on the bottom side of the antenna. In this case, make sure that the surface of the bracket is clean and dry. Pull the foil off the adhesive surface. Press the antenna firmly onto the bracket.
- Fix the antenna firmly to the mounting bracket using the nut and washer supplied.

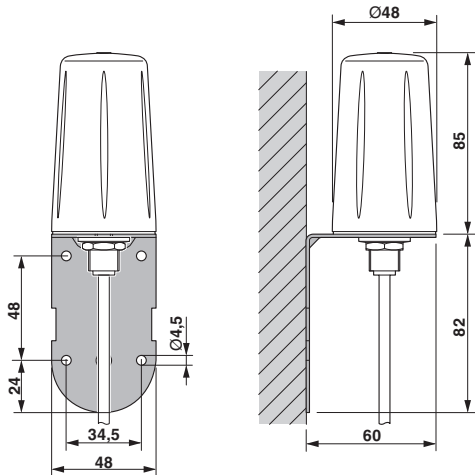

Figure 7 TC ANT MOBILE WALL 0,5M, wall mounting

5.3 Mounting on a surface

Selecting the mounting location

For optimum performance, mount the antenna on a sufficiently dimensioned electrically conductive grounding plate. Plates with a thickness of 1 mm ... 13 mm and a diameter of at least 200 mm are suitable. Note that there must be a gap of at least 30 centimeters between the antenna and other metallic parts.

Make sure that there is sufficient space underneath the mounting surface.

If you use two antennas on a 4G mobile communications device (MIMO), allow at least 20 centimeters distance between the antennas. This way, you will achieve optimum reception.

Mounting

- Cover the plate around the hole to be drilled in order to protect the surface.
- Drill a small hole and enlarge it to a diameter of 14 mm. Make sure that you do not damage any parts underneath the drill hole with the drill.
- Clean the surface surrounding the drill hole and remove any chipping. Remove paint and primer on the bottom side of the plate. Sufficient electrical contact must be ensured via the washer and the nut.
- Remove the washer and the nut from the antenna. Pull the foil off the adhesive surface.
- Feed the antenna cable through the drill hole.
- Press the antenna firmly onto the plate.
- Secure the antenna underneath the plate using the washer and nut. Tighten the nut.

5.4 Laying the antenna cable

- Route the antenna cable to the device.
- Do not route the cable in the immediate vicinity of other cables.
- Make sure that moving parts do not knock against the antenna cable.

6 PSI-GSM/UMTS-QB-ANT and TC ANT MOBILE/GPS

	PSI-GSM/UMTS-QB-ANT 2313371	TC ANT MOBILE/GPS 2903590
Frequency range	850 MHz / 900 MHz / 1800 MHz / 1900 MHz / 2100 MHz	
Gain (depending on frequency and connection assembly)		
800 MHz / 900 MHz	5 dBi	5 dBi
1800 MHz / 1900 MHz	3 dBi	3 dBi
2100 MHz	1 dBi	1 dBi
GPS	-	25 dBi
Standing wave ratio mobile network (VSWR)	<2	
Standing wave ratio GPS (VSWR)	-	Typ. 1.5
General data		
Function	Multiband mobile antenna for UMTS and quad band GSM, with omnidirectional characteristics	Combined mobile GPS antenna with omnidirectional characteristics
Ambient temperature range	-40°C ... 85°C	
Connection	2 m antenna cable with SMA circular connector	2 m antenna cable with SMA circular connector (GSM/UMTS) and R-SMA circular connector (GPS)
Dimensions		
Height	21 mm	23 mm
Diameter	76 mm	76 mm
Degree of protection (mounted)	IP69K	IP69K

6.1 Mounting



Figure 8 Antenna for mounting on the control cabinet

- Drill a hole with a diameter of 16.5 mm into the top of the control cabinet.
- When mounting, please note that the antenna has a diameter of 76 mm. The cable has a length of 2 meters.
- Secure the antenna using the washer and nut provided.

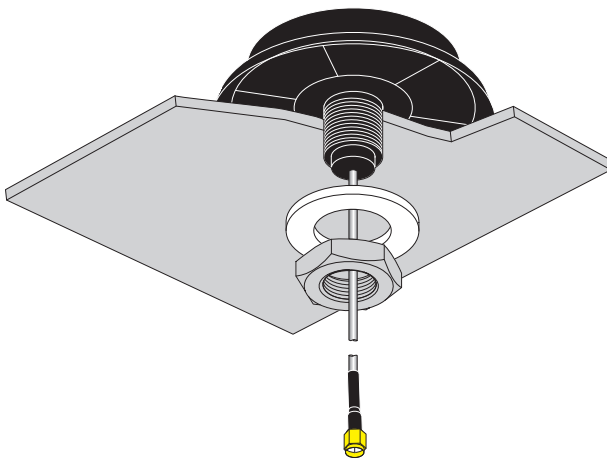

Figure 9 Mounting

7 TC ANT MOBILE CABINET 10M

This antenna is especially suited for mounting on the control cabinet. A 10 m antenna cable is supplied as standard.

TC ANT MOBILE CABINET 10M		1046361
Frequency range	850 MHz / 900 MHz / 1800 MHz / 1900 MHz / 2100 MHz	
Standing wave ratio (VSWR)	<2	
Gain (depending on frequency and connection assembly)	Typical 2.2 dBi	
General data		
Function	Multiband mobile antenna for UMTS and quad band GSM, with omnidirectional characteristics	
Ambient temperature range	-40°C ... 85°C	
Connection	10 m antenna cable with SMA circular connector	
Dimensions (mounted)		
Height	15.9 mm	
Diameter	77.4 mm	
Material		
Cover	ABS	
Plate	Zamak	
Seal	TPE	
Degree of protection (mounted)	IP69K	

7.1 Dimensions

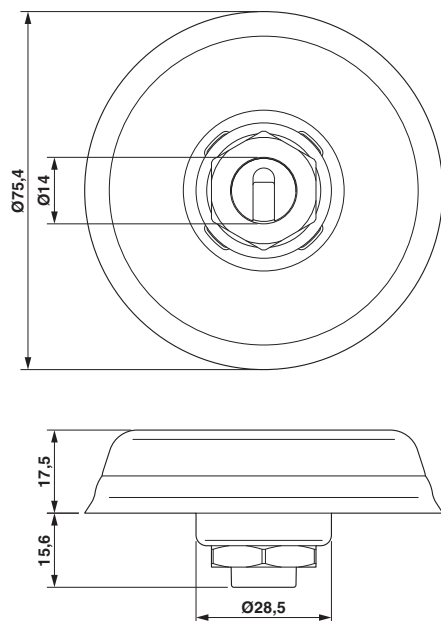

Figure 10 Dimensions

7.2 Mounting



Figure 11 Antenna for mounting on the control cabinet

- Drill a hole with a diameter of 18.9 mm into the top of the control cabinet.
- When mounting, please note that the antenna has a diameter of 77.4 mm. The cable has a length of 10 meters.
- Secure the antenna using the washer and nut provided.

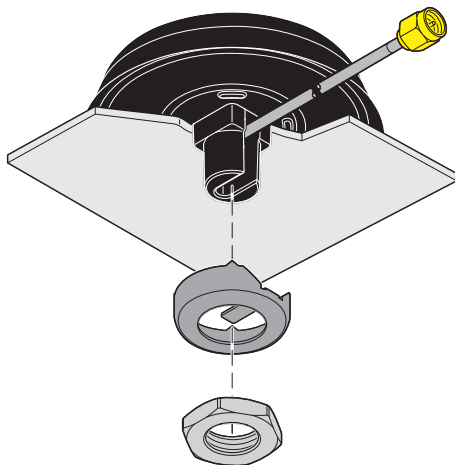

Figure 12 Mounting

8 Antenna cables

Each antenna cable is equipped with an SMA connector and socket. You can simply mount them without an additional adapter between the antenna and device.

	PSI-CAB-GSM/UMTS- 5M	PSI-CAB-GSM/UMTS-10M
	2900980	2900981
Length	5 meters	10 meters
Cable attenuation		
850 MHz	1.15 dB	2.3 dB
900 MHz	1.2 dB	2.4 dB
1800 MHz	1.75 dB	3.5 dB
2100 MHz	1.95 dB	3.9 dB
2600 MHz	2.2 dB	4.4 dB
Impedance	50 Ω	
Frequency range	850 MHz / 900 MHz / 1800 MHz / 1900 MHz / 2100 MHz / 2600 MHz	
Connection	SMA (male) - SMA (female)	
Bending radius, permanent	82 mm	
Outside diameter	5.5 mm	
Material of outer sheath	LSFH	
Ambient temperature range	-40°C ... 85°C	



We recommend using only one of these cables in applications. Otherwise attenuation is too high.



Figure 13 Antenna cables



SCATTERGOOD & JOHNSON LTD

ELECTRICAL ENGINEERING & FLUID CONTROL DISTRIBUTORS

Est.1899

At Scattergood & Johnson Ltd, we pride ourselves on being a technical distributor to specialist industries.

Working with a range of quality product suppliers across a number of specialist markets, we are not your average 'box shifter' - we are your technical and supply chain partner.

We fully support every product we sell - for free! Our internal team and external sales engineers can answer any product or application question, no matter the complexity.

Backing up this technical ability is a range of 50,000+ products available from stock for nationwide next day delivery (same day if required!), or you can collect what you need from any of our trade counters around the UK.

Select your specialist interest below to learn more about how we can help.



Online, In Branch and On the Road - Scattergood & Johnson Ltd, there when you need us.

www.scatts.co.uk