

# AXL BK PN (-ME)

## Axioline bus coupler for PROFINET

Data sheet  
7992\_en\_03

© PHOENIX CONTACT 2014-09-18

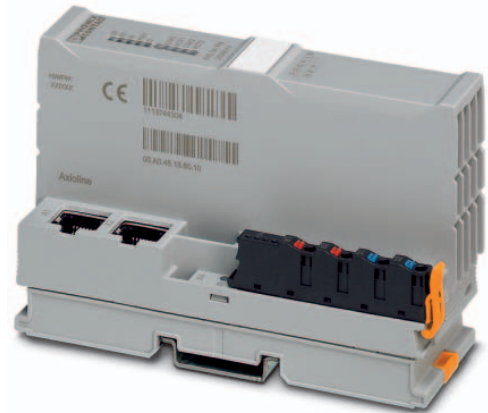

### 1 Description

The bus coupler links a PROFINET network with the Axioline system.

Up to 63 Axioline devices can be connected to an existing PROFINET system using the bus coupler.

For startup tests you can put the Axioline station into operation independent of the higher-level network either using the service interface or an Ethernet port at the bus coupler.

#### Features

- Connection of up to 63 other Axioline devices
- 2 Ethernet ports (with integrated switch)
- Typical cycle time of the Axioline system bus: 10  $\mu$ s, approximately
- PROFINET RT
- Minimum cycle time of PROFINET for RT is 250  $\mu$ s
- Runtime in the bus coupler is negligible (goes to 0  $\mu$ s)
- Firmware can be updated
- Diagnostic and status indicators



This data sheet is only valid in association with the UM EN AXL F SYS INST user manual.  
For information on PROFINET basics, please refer to the UM EN PROFINET SYS user manual.



Make sure you always use the latest documentation.  
It can be downloaded from the product at [phoenixcontact.net/products](http://phoenixcontact.net/products).  
Here you will also find the current GSDML file.

---

<b>2</b>	<b>Table of contents</b>	
1	Description .....	1
2	Table of contents .....	2
3	Ordering data .....	3
4	Technical data .....	4
5	Internal circuit diagram .....	7
6	Connecting PROFINET and supply .....	8
	6.1 Connecting PROFINET .....	8
	6.2 Connecting the supply voltage - terminal point assignment.....	8
7	Connection example.....	8
8	Local status and diagnostic indicators .....	9
9	Diagnostic indicators for PROFINET .....	10
10	Diagnostic alarms .....	10
11	Device replacement.....	11
12	Phoenix Redundancy Layer (PRL) .....	11
13	Dynamic configuration on the local bus .....	11
14	Substitute value behavior .....	11
15	Startup.....	11
16	Parameterization .....	12
17	Firmware update.....	12

### 3 Ordering data

Description	Type	Order No.	Pcs. / Pkt.
Axioline bus coupler for PROFINET (including bus base module and connector)	AXL BK PN	2688019	1
Axioline bus coupler for PROFINET (electronic module as a replacement for item 2688019 AXL BK PN)	AXL BK PN-ME	2688132	1
Accessories	Type	Order No.	Pcs. / Pkt.
Axioline F long power connector (for e.g., AXL BK PN) (Replacement item)	AXL CN L/UL	2700979	1
RJ45 connector, shielded, with bend protection sleeve, 2 pieces, gray for straight cables, for assembly on site. For connections that are not crossed, it is recommended that you use the connector set with gray bend protection sleeve. (Connector/Adapter)	FL PLUG RJ45 GR/2	2744856	1
RJ45 connector, shielded, with bend protection sleeve, 2 pieces, green for crossed cables, for assembly on site. For connections that are not crossed, it is recommended that the connector set with green bend protection sleeves is used. (Connector/Adapter)	FL PLUG RJ45 GN/2	2744571	1
CAT5-SF/UTP cable (J-02YS(ST)C HP 2 x 2 x 24 AWG), heavy-duty installation cable, 2 x 2 x 0.22 mm <sup>2</sup> , solid conductor, shielded, outer sheath: 7.8 mm diameter, inner sheath: 5.75 mm ± 0.15 mm diameter (Cable/conductor)	FL CAT5 HEAVY	2744814	1
CAT5-SF/UTP cable (J-LI02YS(ST)C H 2 x 2 x 26 AWG), light-duty, flexible installation cable 2 x 2 x 0.14 mm <sup>2</sup> , stranded, shielded, outer sheath: 5.75 mm ± 0.15 mm diameter (Cable/conductor)	FL CAT5 FLEX	2744830	1
Crimping pliers, for assembling the RJ45 plugs FL PLUG RJ45..., for assembly on site (Tools)	FL CRIMPTOOL	2744869	1
Programming adapter with USB interface, for programming with the IFSCONF, MACX-MCR-CONF and UPS-CONF software (Cable/conductor)	IFS-USB-PROG-ADAPTER	2811271	1
Zack marker strip for Axioline F (device labeling), in 2 x 20.3 mm pitch, unprinted, 25-section, for individual labeling with B-STIFT 0.8, X-PEN, or CMS-P1-PLOTTER (Marking)	ZB 20,3 AXL UNPRINTED	0829579	25
Zack marker strip, flat, in 10 mm pitch, unprinted, 10-section, for individual labeling with M-PEN 0.8, X-PEN, or CMS-P1-PLOTTER (Marking)	ZBF 10/5,8 AXL UNPRINTED	0829580	50
Software for starting up and parameterizing Axioline stations	STARTUP+	2700636	1
Documentation	Type	Order No.	Pcs. / Pkt.
User manual, English, Axioline F: System and installation	UM EN AXL F SYS INST	-	-
User manual, English, PROFINET basics	UM EN PROFINET SYS	-	-
Application note, English, Firmware update for devices supporting a TFTP firmware update	AH EN TFTP FIRMWARE UPDATE	-	-

## 4 Technical data

### Dimensions (nominal sizes in mm)

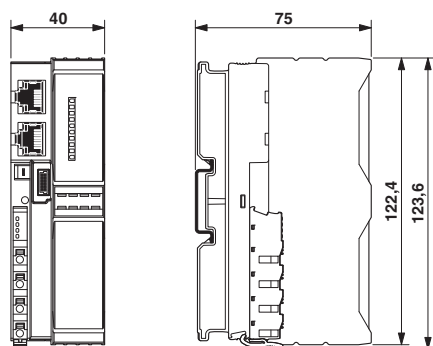

Width	40 mm
Height	123.6 mm
Depth	75 mm
Note on dimensions	The depth is valid when a TH 35-7.5 DIN rail is used (according to EN 60715).

### General data

Color	gray
Weight	173 g (with connector)
Ambient temperature (operation)	-25 °C ... 60 °C
Ambient temperature (storage/transport)	-40 °C ... 85 °C
Permissible humidity (operation)	5 % ... 95 % (according to DIN EN 61131-2)
Permissible humidity (storage/transport)	5 % ... 95 % (according to DIN EN 61131-2)
Air pressure (operation)	70 kPa ... 106 kPa (up to 3000 m above sea level)
Air pressure (storage/transport)	70 kPa ... 106 kPa (up to 3000 m above sea level)
Degree of protection	IP20
Protection class	III, IEC 61140, EN 61140, VDE 0140-1

### Connection data

Connection method	Spring-cage connection with direct connector-in method
Conductor cross section solid / stranded	0.2 mm <sup>2</sup> ... 1.5 mm <sup>2</sup> / 0.2 mm <sup>2</sup> ... 1.5 mm <sup>2</sup>
Conductor cross section [AWG]	24 ... 16

### Interface PROFINET

Number	2
Connection method	RJ45 socket, auto negotiation and autocrossing
Transmission speed	100 MBit/s (Full duplex)
Transmission physics	Ethernet in RJ45 twisted pair
Transmission length	max. 100 m

### Interface Axioline F local bus

Connection method	Connection for bus base module
Transmission speed	100 MBit/s

**Interface Service**

Number	1
Connection method	IFS-USB-PROG-ADAPTER

**System limits**

Amount of process data	1485 Byte (for each data direction)
Number of supported devices	max. 63 (per station)

**NOTE: Electronics may be damaged when overloaded**

Observe the logic current consumption of each device when configuring an Axioline station. It is specified in every module-specific data sheet. The current consumption can differ depending on the individual module. The permissible number of devices that can be connected therefore depends on the specific station structure.

**PROFINET**

Device function	PROFINET device
Conformance class	B
Update rate	250 $\mu$ s
Number of supported application relationships (AR)	2

**Protocols supported**

Protocols supported	PROFINET, FTP, TFTP, LLDP, SNMP, MRP, DDI, BootP
---------------------	--

**Supported MIBs**

Supported standard MIBs	RFC 1213 (MIB II)
Supported private MIBs	Phoenix Contact MIB

**Supply of the bus coupler**

Supply of communications power $U_L$	24 V DC
Maximum permissible voltage range	19.2 V DC ... 30 V DC (including all tolerances, including ripple)
Current supply at $U_{Bus}$	2 A
Current consumption from $U_L$	typ. 86 mA (without I/Os and $U_L = 24$ V) max. 600 mA (with 2 A at $U_{Bus}$ for the I/Os and $U_L = 24$ V) max. 750 mA (with 2 A load at $U_{Bus}$ for the I/Os and $U_L = 19$ V)
Power consumption at $U_L$	typ. 2 W (without I/Os) max. 14.4 W (with 2 A load at $U_{Bus}$ for the I/Os)

**NOTE: Electronics may be damaged when overloaded**

Provide external fuses for the 24 V  $U_L$  area. The power supply unit must be able to supply four times the nominal current of the external fuse to ensure that it blows in the event of an error.

**Error messages to the higher level control or computer system**

None

**Mechanical tests**

Vibration resistance in acc. with EN 60068-2-6/IEC 60068-2-6	5g
Shock in acc. with EN 60068-2-27/IEC 60068-2-27	25g, 11 ms period, half-sine shock pulse
Continuous shock according to EN 60068-2-27/IEC 60068-2-27	10g

**Conformance with EMC Directive 2004/108/EC****Noise immunity test in accordance with EN 61000-6-2**

Electrostatic discharge (ESD) EN 61000-4-2/IEC 61000-4-2	Criterion B; 6 kV contact discharge, 8 kV air discharge
Electromagnetic fields EN 61000-4-3/IEC 61000-4-3	Criterion A; Field intensity: 10 V/m
Fast transients (burst) EN 61000-4-4/IEC 61000-4-4	Criterion B, 2 kV

**Conformance with EMC Directive 2004/108/EC**

Conducted interference EN 61000-4-6/IEC 61000-4-6                      Criterion A; Test voltage 10 V

**Noise emission test according to EN 61000-6-3**

Radio interference properties EN 55022                                      Class B

**Approvals**

For the latest approvals, please visit [phoenixcontact.net/products](http://phoenixcontact.net/products).

## 5 Internal circuit diagram

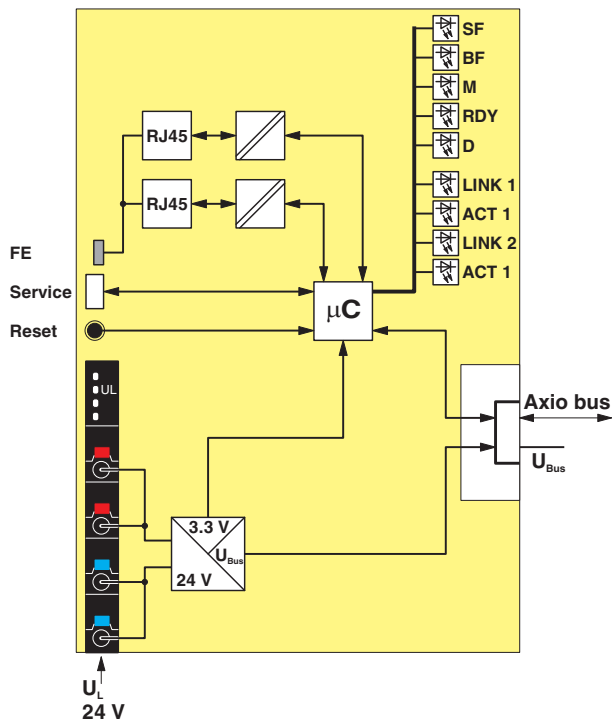

Figure 1 Internal wiring of the terminal points

Key:

FE Optional functional earth ground connection

Service Service interface

Reset Reset button

RJ45 RJ45 interface



μC Microprocessor



Power supply unit



LED



## 6 Connecting PROFINET and supply

### 6.1 Connecting PROFINET

Connect PROFINET to the bus coupler via an 8-pos. RJ45 connector.

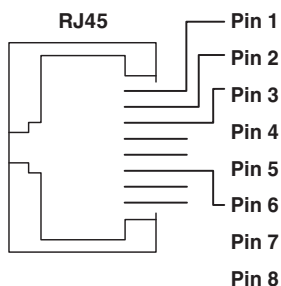

Figure 2 Pin assignment of the Ethernet socket (RJ45)

Only one twisted pair cable with an impedance of 100 Ω may be connected to each Ethernet interface in RJ45 format. The data transmission speed is 100 Mbps. The 100Base-TX port of the bus coupler is able to detect a pair of incorrectly connected receive cables (RD+/RD-) and to correct them using the auto polarity correction function.

For the pin assignment, please refer to the following table:

Pin	Assignment
1	TxD + (transmit data +)
2	TxD - (transmit data -)
3	RxD+ (receive data +)
4	Reserved
5	Reserved
6	RxD- (receive data -)
7	Reserved
8	Reserved



**Auto crossover**  
Both Ethernet interfaces are provided with the auto crossover function.



**Shielding**  
The shielding ground of the connected twisted pair cables is electrically connected with the socket. When connecting network segments, avoid ground loops, potential transfers, and voltage equalization currents via the braided shield.



**Observe bending radii**  
The housing dimensions specified under "Dimensions" refer to the bus coupler with I/O connectors without Ethernet connection. When installing the bus coupler in a control box, observe the bending radii of the Ethernet cables and the connectors used (e.g., FL CAT5 FLEX: 30 mm for fixed installation and FL CAT5 HEAVY: 30 mm without outer sheath and 45 mm with outer sheath). If required, use angled RJ45 connectors to maintain these bending radii.

### 6.2 Connecting the supply voltage - terminal point assignment

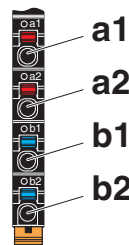

Figure 3 Terminal point assignment

Terminal point	Color	Assignment
<b>Supply voltage input</b>		
a1, a2	Red	24 V DC (U <sub>L</sub> ) Supply of the logic voltage (internally jumpered)
b1, b2	Blue	GND Reference potential of the supply voltage (internally jumpered)

## 7 Connection example

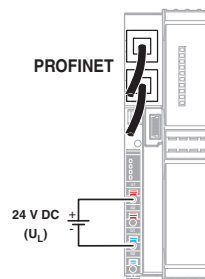

Figure 4 Connection of the cables

## 8 Local status and diagnostic indicators

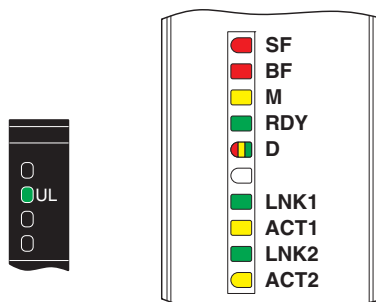

Figure 5 Local status and diagnostic indicators

Designation	Color	Meaning	State	Description
UL	Green	$U_{Logic}$	ON	Communications power supply present.
			OFF	Communications power supply not present.
SF	Red	System failure (PROFINET)	ON	PROFINET diagnostics available
			OFF	PROFINET diagnostics not available
			Flashing	Flashes only together with the BF LED; watchdog triggered
BF	Red	Communication error (Bus-Fail)	ON	No link status available on any port
			Flashing	SF LED not flashing: Link status available, no communication connection to the PROFINET controller
			Flashing	SF flashing: Hardware watchdog triggered
			OFF	A PROFINET controller has established an active communication connection to the PROFINET device.
M	Yellow	Maintenance	OFF	There is no maintenance request of a local bus device.
			ON	There is at least one maintenance request of a local bus device (e.g., device temperature at permissible limit).
RDY	Green	Ready	ON	Device ready to operate
			OFF	Device is not ready to operate.
			Flashing	Device booting (for firmware update with boot requests)
D	Red/ yellow/ green	Diagnostics	Red ON	Bus error
			Yellow ON	Ready: Device is ready to operate, no data is exchanged.
			Yellow flashing	I/O error in ACTIVE
			Green ON	Run: Data exchange; status and data from the higher-level system is transmitted.
			Green flashing	Active: configuration is active, data exchange with invalid process data, PDI channel can be used.
			Green/ yellow alternating	I/O error in RUN

Designation	Color	Meaning	State	Description
LNK 1/2	Green	Link port 1/2	ON	Connection via Ethernet to a module via port 1/2 established
			Flashing	PROFINET module identification ("flashing")
			OFF	No connection established via port 1/2
ACT 1/2	Yellow	Activity port 1/2	ON	Transmission or reception of Ethernet telegrams at port 1/2
			OFF	No transmission or reception of Ethernet telegrams at port 1/2

## 9 Diagnostic indicators for PROFINET

### States during operation

LED	Meaning
SF OFF/ BF flashing	PROFINET controller was able to establish communication without errors.

### States in the event of an error

LED	Meaning	Measure/remedy in the event of an error
SF OFF/ BF flashing	PROFINET device is waiting for communication with the PROFINET controller.	No error
	The logic communication connection has been interrupted. The PROFINET controller can no longer be accessed.	Check the connection between the PROFINET controller and the PROFINET device. Make sure that the PROFINET device name of the PROFINET device is identical with the configuration.
	The PROFINET device is not assigned a PROFINET device name.	Assign the PROFINET device name using the relevant tool.
SF OFF/ BF ON	The physical communication path has been interrupted. The PROFINET controller can no longer be accessed.	Restore the physical connection between the PROFINET controller and the PROFINET device.

LED	Meaning	Measure/remedy in the event of an error
SF ON/ BF OFF	Diagnostic data is available.	Read the diagnostic message using the relevant tool.
SF flashing/ BF flashing	Hardware watchdog has been triggered.	Execute a reset. Replace the device when the error occurs again.

### States during firmware update

LED	Meaning
RDY flashing	BootP requests are sent and the firmware container is loaded via tftp.
RDY ON / M ON	Firmware is saved.



The firmware update can take several minutes.

The bus coupler is restarted automatically after a successful update.

## 10 Diagnostic alarms

PROFINET enables the PROFINET device to store diagnostic information together with the error location and error type.

In the default upon delivery the alarms are enabled, however, they can be disabled with parameters on startup.

An incoming alarm informs the PROFINET controller that diagnostic information has been stored.

When the diagnostic information has been removed, an outgoing alarm is transmitted to the controller.

If at least one piece of diagnostic information is stored, the SF LED is on. If no diagnostic information is present, the SF LED is off.

## 11 Device replacement

Devices can be replaced without having to reconfigure them within the PROFINET network. The station name and address are assigned by the control system to the newly added PROFINET bus coupler using the neighborhood detection function.

## 12 Phoenix Redundancy Layer (PRL)

The Phoenix Redundancy Layer (PRL) makes it possible to design a redundant system with two PROFINET controllers. One controller is configured as the primary I/O controller and the other as the backup I/O controller. Depending on which PROFINET controller provides valid values, the bus coupler operated at field level adopts these values or uses failsafe values.

The bus coupler supports PRL as of Firmware Version 1.20.



PRL (or shared device) and MRP can be used simultaneously if the PROFINET update time is  $\geq 8$  ms and the PROFINET watchdog time is  $> 200$  ms.

## 13 Dynamic configuration on the local bus

You can use the "Dynamic configuration" function with this bus coupler.

Dynamic configuration is the specification and configuration of a maximum configuration. Any subgroup of this maximum configuration can be operated.

## 14 Substitute value behavior

When PROFINET communication breaks down or an error occurs in the local bus, all outputs of the Axioline F station are set to the parameterized substitute values. The local bus continues to run with these values.

## 15 Startup

### Default upon delivery/default settings

By default upon delivery, the following functions and features are available:

PROFINET name:	No name assigned
IP parameters:	0.0.0.0
Module designation:	AXL BK PN-ME

Vendor ID:	00B0 <sub>hex</sub>
Device ID:	1000 <sub>hex</sub>



PROFINET controllers from Phoenix Contact support the "Operation with differences in configuration yes/no" function from version 3.70 or later.

If you are using an earlier firmware version, set the "Operation with configuration differences" function to "yes" in the context menu of the bus coupler under the "PROFINET settings" tab.

When configuration differences are detected, this prevents that data from the application is briefly being output at the outputs of the configured modules before operation is terminated completely.

### Firmware started

Once you have supplied the bus coupler with power or pressed the reset button, the firmware is started. After completion of the firmware boot process the BF LED is either on or flashing.

### Reset button

The reset button is on the front of the bus coupler.

The bus coupler is restarted by pressing the reset button. The outputs of the station are set to the parameterized substitute values. The process image of the inputs is not re-read.

### Documentation



How to assign the PROFINET names and the IP address as well as how to startup a device within a PROFINET system is described in the following documents:

- "PC WORX" quick start guide
- "Configuring INTERBUS devices in a PROFINET network using the example of STEP 7" quick start guide

For the order designations, please refer to the ordering data.

The documentation can be found on the Internet at [phoenixcontact.net/products](http://phoenixcontact.net/products).

## 16 Parameterization

### PC Worx

Parameterization of the PROFINET devices in PC Worx requires at least PC Worx version 6.0. It is part of the AUTOMATIONWORX Software Suite 1.50, service pack 3.

An online data sheet of the device with important technical data and a configuration file are integrated into PC Worx. If several versions of the configuration file are available, make sure that you are working with the file version that corresponds to the firmware/hardware version used.

### Other tools

The PROFINET device is parameterized using the configuration tool of the PROFINET controller. Please integrate the corresponding GSDML file of the bus coupler into the relevant software tool (STEP 7/HW Config, ...).



Make sure you always use the latest version of the FDCML/GSDML file and the latest documentation for the bus coupler. The latest files and documentation can be found on the Internet at [phoenixcontact.net/products](http://phoenixcontact.net/products).

## 17 Firmware update

In order to update the firmware of the bus coupler, the device must be provided with a firmware container via a TFTP server. You can use any TFTP server, e.g., Factory Manager.



The TFTP FIRMWARE UPDATE application note describes how to update the firmware using the Factory Manager. This document can be found on the Internet at [phoenixcontact.net/products](http://phoenixcontact.net/products).

Please refer to the "Diagnostic indicators for PROFINET" section for the LED states during the firmware update.



# SCATTERGOOD & JOHNSON LTD

ELECTRICAL ENGINEERING & FLUID CONTROL DISTRIBUTORS

Est.1899

At Scattergood & Johnson Ltd, we pride ourselves on being a technical distributor to specialist industries.

Working with a range of quality product suppliers across a number of specialist markets, we are not your average 'box shifter' - we are your technical and supply chain partner.

We fully support every product we sell - for free! Our internal team and external sales engineers can answer any product or application question, no matter the complexity.

Backing up this technical ability is a range of 50,000+ products available from stock for nationwide next day delivery (same day if required!), or you can collect what you need from any of our trade counters around the UK.

Select your specialist interest below to learn more about how we can help.



Online, In Branch and On the Road - Scattergood & Johnson Ltd, there when you need us.

# [www.scatts.co.uk](http://www.scatts.co.uk)