

# AXL F DO16/3 2F

**Axioline F, digital output module,  
digital outputs: 16, 24 V DC, 500 mA,  
connection method: 2-, 3-wire**

Data sheet  
7988\_en\_04

© PHOENIX CONTACT 2019-01-24



## 1 Description

The module is designed for use within an Axioline F station. It is used to output digital signals. The outputs are protected against short circuit and overload.

### Features

- 16 digital outputs
- 24 V DC, 500 mA
- Connection of actuators in 2 and 3-wire technology
- Minimum update time of < 100 µs
- Device rating plate stored
- Approved for use in applications which meet functional safety requirements

**Valid for hardware Version 05, firmware Version 1.00 or later.**



The deviating behavior of the modules with an earlier hardware revision is documented in the corresponding points.



Observe the corresponding notes when using the module in applications which meet functional safety requirements.



This data sheet is only valid in association with the UM EN AXL F SYS INST user manual.



Make sure you always use the latest documentation.  
It can be downloaded at: [phoenixcontact.net/product/2688048](https://phoenixcontact.net/product/2688048)

---

|          |                                                                                           |    |
|----------|-------------------------------------------------------------------------------------------|----|
| <b>2</b> | <b>Table of contents</b>                                                                  |    |
| 1        | Description .....                                                                         | 1  |
| 2        | Table of contents .....                                                                   | 2  |
| 3        | Ordering data .....                                                                       | 3  |
| 4        | Technical data .....                                                                      | 4  |
| 5        | Maximum outputs power consumption when inductive loads are switched off .....             | 8  |
| 6        | Internal circuit diagram .....                                                            | 8  |
| 7        | Terminal point assignment.....                                                            | 9  |
| 8        | Connection example.....                                                                   | 9  |
| 9        | Local diagnostic and status indicators .....                                              | 10 |
| 10       | Notes on using the module in applications which meet Functional Safety requirements ..... | 12 |
| 11       | Process data.....                                                                         | 12 |
| 12       | Parameter, diagnostics and information (PDI) .....                                        | 12 |
| 13       | Standard objects .....                                                                    | 13 |
|          | 13.1 Objects for identification (device rating plate).....                                | 13 |
|          | 13.2 Miscellaneous standard objects .....                                                 | 14 |
|          | 13.3 Diagnostics objects .....                                                            | 15 |
|          | 13.4 Objects for process data management.....                                             | 17 |
| 14       | Application objects .....                                                                 | 17 |
|          | 14.1 Substitute value behavior (FF8Dhex: PD Output Substitute Configuration) .....        | 17 |
|          | 14.2 Message "Actuator supply not present" (FF8Fhex: DiagOut).....                        | 17 |
| 15       | Device descriptions .....                                                                 | 18 |

### 3 Ordering data

| Description                                                                                                                                                                                                                        | Type                     | Order No. | Pcs./Pkt. |
|------------------------------------------------------------------------------------------------------------------------------------------------------------------------------------------------------------------------------------|--------------------------|-----------|-----------|
| Axioline F, digital output module, digital outputs: 16, 24 V DC, 500 mA, connection method: 3-wire, transmission speed in the local bus: 100 Mbps, degree of protection: IP20, including bus base module and Axioline F connectors | AXL F DO16/3 2F          | 2688048   | 1         |
| <b>Accessories</b>                                                                                                                                                                                                                 |                          |           |           |
| Axioline F bus base module for housing type F (Replacement item)                                                                                                                                                                   | AXL F BS F               | 2688129   | 5         |
| Axioline F connector set (for e.g., AXL F DO16/3 2F) (Replacement item)                                                                                                                                                            | AXL CNS 8L-OBBG/D/UO/E1  | 2700981   | 1         |
| Zack marker strip for Axioline F (device labeling), in 2 x 20.3 mm pitch, unprinted, 25-section, for individual labeling with B-STIFT 0.8, X-PEN, or CMS-P1-PLOTTER (Marking)                                                      | ZB 20,3 AXL UNPRINTED    | 0829579   | 25        |
| Zack marker strip, flat, in 10 mm pitch, unprinted, 10-section, for individual labeling with M-PEN 0,8, X-PEN, or CMS-P1-PLOTTER (Marking)                                                                                         | ZBF 10/5,8 AXL UNPRINTED | 0829580   | 50        |
| <b>Documentation</b>                                                                                                                                                                                                               |                          |           |           |
| User manual, English, Axioline F: System and installation                                                                                                                                                                          | UM EN AXL F SYS INST     | -         | -         |
| User manual, English, Axioline F: Diagnostic registers, and error messages                                                                                                                                                         | UM EN AXL F SYS DIAG     | -         | -         |
| Application note, English, Using devices of the Axioline F product range in safety applications                                                                                                                                    | AH EN AXL F SAFE         | -         | -         |

## 4 Technical data

### Dimensions (nominal sizes in mm)

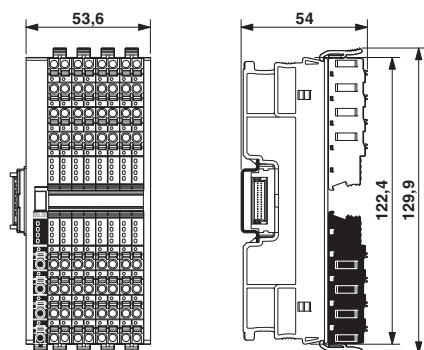

|                    |                                                                               |
|--------------------|-------------------------------------------------------------------------------|
| Width              | 53.6 mm                                                                       |
| Height             | 129.9 mm                                                                      |
| Depth              | 54 mm                                                                         |
| Note on dimensions | The depth is valid when a TH 35-7,5 DIN rail is used (according to EN 60715). |

### General data

|                                          |                                                   |
|------------------------------------------|---------------------------------------------------|
| Color                                    | traffic grey A RAL 7042                           |
| Weight                                   | 234 g (with connectors and bus base module)       |
| Ambient temperature (operation)          | -25 °C ... 60 °C                                  |
| Ambient temperature (storage/transport)  | -40 °C ... 85 °C                                  |
| Permissible humidity (operation)         | 5 % ... 95 % (non-condensing)                     |
| Permissible humidity (storage/transport) | 5 % ... 95 % (non-condensing)                     |
| Air pressure (operation)                 | 70 kPa ... 106 kPa (up to 3000 m above sea level) |
| Air pressure (storage/transport)         | 70 kPa ... 106 kPa (up to 3000 m above sea level) |
| Degree of protection                     | IP20                                              |
| Protection class                         | III, IEC 61140, EN 61140, VDE 0140-1              |
| Mounting position                        | any (no temperature derating)                     |

### Connection data: Axioline F connector

|                                          |                                                                                           |
|------------------------------------------|-------------------------------------------------------------------------------------------|
| Connection method                        | Push-in connection                                                                        |
| Conductor cross section solid / stranded | 0.2 mm <sup>2</sup> ... 1.5 mm <sup>2</sup> / 0.2 mm <sup>2</sup> ... 1.5 mm <sup>2</sup> |
| Conductor cross section [AWG]            | 24 ... 16                                                                                 |
| Stripping length                         | 8 mm                                                                                      |



Please observe the information provided on conductor cross sections in the "Axioline F: system and installation" user manual.

**Interface: Axioline F local bus**

|                    |                 |
|--------------------|-----------------|
| Number             | 2               |
| Connection method  | Bus base module |
| Transmission speed | 100 Mbps        |

**Axioline F local bus supply ( $U_{Bus}$ )**

|                   |                                                       |
|-------------------|-------------------------------------------------------|
| Supply voltage    | 5 V DC (via bus base module)                          |
| Current draw      | max. 120 mA (up to HW 04)<br>max. 60 mA (from HW 05)  |
| Power consumption | max. 600 mW (up to HW 04)<br>max. 300 mW (from HW 05) |

**Supply for digital output modules ( $U_O$ )**

|                                                    |                                                                                      |
|----------------------------------------------------|--------------------------------------------------------------------------------------|
| Supply voltage                                     | 24 V DC                                                                              |
| Supply voltage range                               | 19.2 V DC ... 30 V DC (including all tolerances, including ripple)                   |
| Current draw                                       | min. 14 mA (without actuators)<br>max. 8 A (provide external protection)             |
| Power consumption                                  | typ. 320 mW (without actuators)<br>max. 240 W (Of which 560 mW with internal losses) |
| Surge protection of the supply voltage             | electronic (35 V, 0.5 s)                                                             |
| Polarity reversal protection of the supply voltage | parallel diode; with external 5 A fuse (only for commissioning)                      |
| Protection                                         | max. 8 A (polarity reversal protection up to 5 A)                                    |

**NOTE: Damage to the electronics**

Provide external protection for the module to protect it against polarity reversal. If you are using an external fuse, the power supply unit must be able to supply four times the nominal current of the fuse. This ensures that it trips in the event of an error.



When using the module for the first time, protect it with a 5 A fuse. When all modules in the system are correctly connected, the 5 A fuse can be replaced with an 8 A fuse. After that, you can load the module up to 8 A. Loads over 8 A are not permitted.

**Digital outputs**

|                                    |                                                                                                               |
|------------------------------------|---------------------------------------------------------------------------------------------------------------|
| Number of outputs                  | 16                                                                                                            |
| Connection method                  | Push-in connection                                                                                            |
| Connection technology              | 3-wire                                                                                                        |
| Nominal output voltage             | 24 V DC                                                                                                       |
| Maximum output current per channel | 500 mA                                                                                                        |
| Maximum output current per device  | 8 A (provide external protection)                                                                             |
| Nominal load, ohmic                | max. 12 W (48 $\Omega$ , with nominal voltage)                                                                |
| Nominal load, inductive            | max. 12 VA (1.2 H, 48 $\Omega$ , with nominal voltage)                                                        |
| Nominal load, lamp                 | max. 12 W (at nominal voltage)                                                                                |
| Signal delay                       | max. 100 $\mu$ s (when switched on)<br>max. 100 $\mu$ s (when switched off; with at least 50 mA load current) |

**Digital outputs**

|                                                           |                                                                                                                                                    |
|-----------------------------------------------------------|----------------------------------------------------------------------------------------------------------------------------------------------------|
| Switching frequency                                       | max. 10000 per second (with at least 50 mA load current)<br>max. 1 per second (with inductive load)<br>max. 16 per second (with nominal lamp load) |
| Load min.                                                 | 10 k $\Omega$                                                                                                                                      |
| Energy consumption                                        | see diagram                                                                                                                                        |
| Limitation of the voltage induced on circuit interruption | -25.8 V ... -15 V                                                                                                                                  |
| Output voltage when switched off                          | max. 1 V                                                                                                                                           |
| Output current when switched off                          | max. 300 $\mu$ A                                                                                                                                   |
| Behavior with overload                                    | Shutdown with automatic restart                                                                                                                    |
| Behavior with inductive overload                          | Output can be destroyed                                                                                                                            |
| Reverse voltage resistance to short pulses                | limited protection up to 0.5 A for 1 s                                                                                                             |

**NOTE: Damage to the electronics**

If there is a faulty external voltage (reverse voltage) at one of the outputs, the output may be destroyed. This may cause unintentional setting of further outputs.

|                                                                   |               |
|-------------------------------------------------------------------|---------------|
| Overcurrent shut-down                                             | as of 0.7 A   |
| Output current with ground connection interrupt when switched off | < 1 mA        |
| Process data update                                               | < 100 $\mu$ s |
| Short-circuit protection, overload protection of the outputs      | electronic    |

**Input and output address area**

|                     |        |
|---------------------|--------|
| Input address area  | 0 Byte |
| Output address area | 2 Byte |

**Configuration and parameter data in a PROFIBUS system**

|                             |        |
|-----------------------------|--------|
| Required parameter data     | 1 Byte |
| Required configuration data | 6 Byte |

**Electrical isolation/isolation of the voltage areas**

| Test section                                        | Test voltage            |
|-----------------------------------------------------|-------------------------|
| 5 V communications power (logic), 24 V supply (I/O) | 500 V AC, 50 Hz, 1 min. |
| 5 V supply (logic)/functional earth ground          | 500 V AC, 50 Hz, 1 min. |
| 24 V supply (I/O) / functional earth ground         | 500 V AC, 50 Hz, 1 min. |

**Mechanical tests**

|                                                                  |     |
|------------------------------------------------------------------|-----|
| Vibration resistance in acc. with EN 60068-2-6/<br>IEC 60068-2-6 | 5g  |
| Shock in acc. with EN 60068-2-27/IEC 60068-2-27                  | 30g |
| Continuous shock according to EN 60068-2-27/<br>IEC 60068-2-27   | 10g |

**Conformance with EMC Directive 2014/30/EU****Noise immunity test in accordance with EN 61000-6-2**

|                                                              |                                                                                         |
|--------------------------------------------------------------|-----------------------------------------------------------------------------------------|
| Electrostatic discharge (ESD) EN 61000-4-2/<br>IEC 61000-4-2 | Criterion B, 6 kV contact discharge, 8 kV air discharge                                 |
| Electromagnetic fields EN 61000-4-3/IEC 61000-4-3            | Criterion A, Field intensity: 10 V/m                                                    |
| Fast transients (burst) EN 61000-4-4/IEC 61000-4-4           | Criterion B, 2 kV                                                                       |
| Transient overvoltage (surge) EN 61000-4-5/<br>IEC 61000-4-5 | Criterion B, DC supply lines: $\pm 0.5$ kV/ $\pm 0.5$ kV (symmetrical/<br>asymmetrical) |
| Conducted interference EN 61000-4-6/IEC 61000-4-6            | Criterion A; Test voltage 10 V                                                          |
| <b>Noise emission test according to EN 61000-6-3</b>         | Class B                                                                                 |

**Approvals**

For the latest approvals, please visit [phoenixcontact.net/products](http://phoenixcontact.net/products).

### 5 Maximum outputs power consumption when inductive loads are switched off



**NOTE: Damage to the electronics**  
 When you use an external freewheel limit, the free-wheeling voltage to a maximum of -15 V. The external freewheel limit has no function with a higher negative voltage.

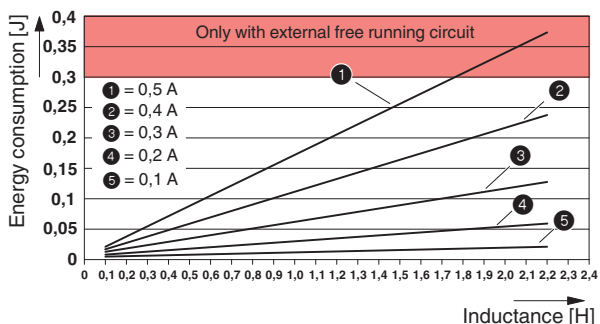

Figure 1 Maximum outputs power consumption when inductive loads are switched off

The diagram shows the maximum power that can be fed back for every switch-off operation in the respective output groups (outputs 1 to 4, 5 to 8, 9 to 12, 13 to 16) when an inductive load is switched off without an external freewheel. The current data refers to the ohmic DC voltage component of the inductive load.

### 6 Internal circuit diagram

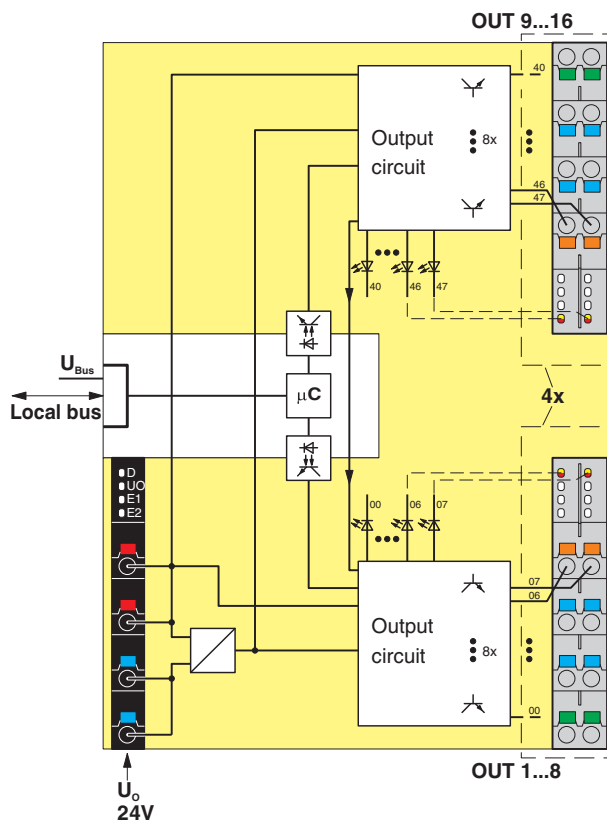

Figure 2 Internal wiring of the terminal points

Key:

- Local bus                      Axioline F local bus (hereinafter referred to as local bus)
- Microcontroller
- Optocoupler
- LED
- Power supply unit
- Electrically isolated areas
- Output configuration

## 7 Terminal point assignment

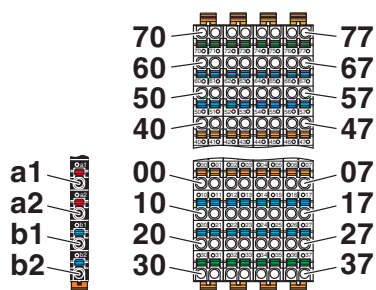

Figure 3 Terminal point assignment

## 8 Connection example

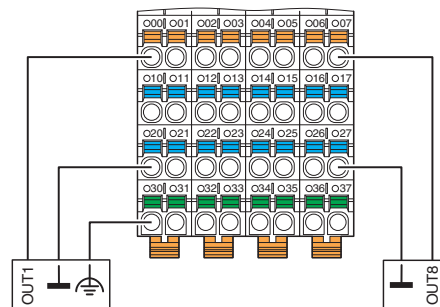
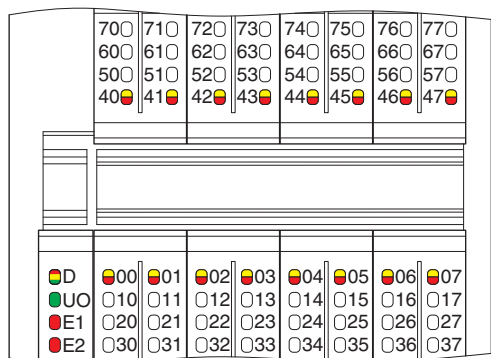

Figure 4 Connection using 3 and 2-wire technology

| Terminal point              | Color  | Assignment                |                                                                |
|-----------------------------|--------|---------------------------|----------------------------------------------------------------|
| <b>Supply voltage input</b> |        |                           |                                                                |
| a1, a2                      | Red    | 24 V DC (U <sub>O</sub> ) | Digital output module feed-in (bridged internally)             |
| b1, b2                      | Blue   | GND                       | Reference potential of the supply voltage (bridged internally) |
| <b>Digital outputs</b>      |        |                           |                                                                |
| 00 ... 07                   | Orange | OUT01 ... OUT08           | Digital outputs 1 ... 8                                        |
| 40 ... 47                   | Orange | OUT09 ... OUT16           | Digital outputs 9 ... 16                                       |
| 10 ... 17, 50 ... 57        | Blue   | GND                       | Reference potential for all channels                           |
| 20 ... 27, 60 ... 67        | Blue   | GND                       | Reference potential for all channels                           |
| 30 ... 37, 70 ... 77        | Green  | FE                        | Functional earth ground (FE)                                   |

## 9 Local diagnostic and status indicators

As of hardware revision 05



Channel errors are errors that can be associated with a channel.  
 Periphery errors are errors that affect the entire module.

Figure 5 Local diagnostic and status indicators

| Designation    | Color                    | Meaning                                | State                 | Description                                                                                                                                                                                                             |
|----------------|--------------------------|----------------------------------------|-----------------------|-------------------------------------------------------------------------------------------------------------------------------------------------------------------------------------------------------------------------|
| D              | Red/<br>yellow/<br>green | Diagnostics of local bus communication |                       |                                                                                                                                                                                                                         |
|                |                          | Run                                    | Green on              | The device is ready for operation, communication within the station is OK.<br>All data is valid. An error has not occurred.                                                                                             |
|                |                          | Active                                 | Green flashing        | The device is ready for operation, communication within the station is OK.<br>The data is <b>not</b> valid. No valid data provided by the controller/higher-level network.<br>There is no error on the module.          |
|                |                          | Device application not active          | Flashing green/yellow | The device is ready for operation, communication within the station is OK.<br>Output data <b>cannot</b> be outputted and/or input data <b>cannot</b> be read.<br>There is a fault on the periphery side of the module.. |
|                |                          | Ready                                  | Yellow on             | The device is ready for operation but did not detect a valid cycle after power-up.                                                                                                                                      |
|                |                          | Connected                              | Yellow flashing       | The device is not (yet) part of the active configuration.                                                                                                                                                               |
|                |                          | Reset                                  | Red on                | The device is ready for operation but has lost the connection to the bus head.                                                                                                                                          |
|                |                          | Not connected                          | Flashing red          | The device is ready for operation but there is no connection to the previously existing device.                                                                                                                         |
|                |                          | Power down                             | Off                   | Device is in (power) reset.                                                                                                                                                                                             |
| U <sub>O</sub> | Green                    | U <sub>Output</sub>                    | On                    | Supply for digital output modules present.                                                                                                                                                                              |
|                |                          |                                        | Off                   | Supply for digital output modules is not present.                                                                                                                                                                       |
| E1             | Red                      | Peripheral fault                       | On                    | I/O error present.                                                                                                                                                                                                      |
|                |                          |                                        | Off                   | No I/O error.                                                                                                                                                                                                           |
| E2             | Red                      | Channel error                          | On                    | Channel error present.                                                                                                                                                                                                  |
|                |                          |                                        | Off                   | Channel error not present.                                                                                                                                                                                              |

| Designation             | Color          | Meaning                                   | State     | Description                           |
|-------------------------|----------------|-------------------------------------------|-----------|---------------------------------------|
| 00 ... 07,<br>40 ... 47 | Red/<br>yellow | Diagnostics /<br>Status of the<br>outputs | Red on    | Short-circuit/overload of the output. |
|                         |                |                                           | Yellow on | Output is set.                        |
|                         |                |                                           | Off       | No error, output is not set.          |

**Deviating behavior up to hardware revision 04**

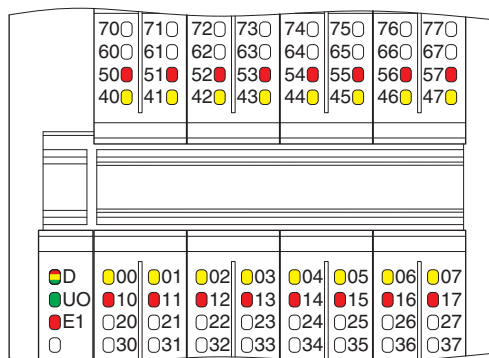

Figure 6 Local diagnostic and status indicators

| Designation             | Color  | Meaning                  | State     | Description                                       |
|-------------------------|--------|--------------------------|-----------|---------------------------------------------------|
| E1                      | Red    | Peripheral fault         | On        | Breakdown or overload/short-circuit of an output. |
|                         |        |                          | Off       | No I/O error.                                     |
| 10 ... 17,<br>50 ... 57 | Red    | Output diagnostics       | On        | Short-circuit/overload of the output.             |
|                         |        |                          | Off       | No short-circuit/overload of the output.          |
| 00 ... 07,<br>40 ... 47 | Yellow | Status of the<br>outputs | Yellow on | Output is set.                                    |
|                         |        |                          | Off       | Output is not set.                                |

## 10 Notes on using the module in applications which meet Functional Safety requirements

As of the specified hardware version, the modules listed below are approved for use in applications which meet functional safety requirements (safety applications).

| Order No. | Type            | As of hardware revision |
|-----------|-----------------|-------------------------|
| 2688048   | AXL F DO16/3 2F | 04                      |



The hardware and firmware version is printed on the left-hand side of the housing on each module.



When using the module in safety applications, also observe the requirements in the AH DE AXL F SAFE / AH EN AXL F SAFE application notes.

The documentation can be found on the Internet at [phoenixcontact.net/products](http://phoenixcontact.net/products).

## 11 Process data

I/O data is mapped in the Motorola format.

### OUT process data

| Byte           | 0      |        |        |        |        |        |        |        |
|----------------|--------|--------|--------|--------|--------|--------|--------|--------|
| Bit            | 7      | 6      | 5      | 4      | 3      | 2      | 1      | 0      |
| Signal         | OUT 08 | OUT 07 | OUT 06 | OUT 05 | OUT 04 | OUT 03 | OUT 02 | OUT 01 |
| Terminal point | 07     | 06     | 05     | 04     | 03     | 02     | 01     | 00     |

| Byte           | 1      |        |        |        |        |        |        |        |
|----------------|--------|--------|--------|--------|--------|--------|--------|--------|
| Bit            | 7      | 6      | 5      | 4      | 3      | 2      | 1      | 0      |
| Signal         | OUT 16 | OUT 15 | OUT 14 | OUT 13 | OUT 12 | OUT 11 | OUT 10 | OUT 09 |
| Terminal point | 47     | 46     | 45     | 44     | 43     | 42     | 41     | 40     |

## 12 Parameter, diagnostics and information (PDI)

Parameter and diagnostic data as well as other information is transmitted as objects via the PDI channel of the Axioline F station.

The standard and application objects stored in the module are described in the following section.

The following applies to all tables below:

Please refer to the UM EN AXL F SYS INST for an explanation of the data types.

| Abbreviation | Meaning                         |
|--------------|---------------------------------|
| A            | Number of elements              |
| L            | Length of the elements in bytes |
| R            | Read                            |
| W            | Write                           |



Each visible string is terminated with a null terminator (00<sub>hex</sub>). The length of a visible-string-type element is therefore at least one byte larger than the number of user data items.

If the number of user data items plus null terminator is smaller than the specified length of the element, the visible string will be populated with a null character (00<sub>hex</sub>).



For detailed information on PDI objects, please refer to the UM EN AXL F SYS INST user manual.

## 13 Standard objects

### 13.1 Objects for identification (device rating plate)

As of hardware revision 05

| Index (hex)              | Object name     | Data type                 | A | L      | Rights | Meaning                    | Contents                                         |
|--------------------------|-----------------|---------------------------|---|--------|--------|----------------------------|--------------------------------------------------|
| <b>Manufacturer</b>      |                 |                           |   |        |        |                            |                                                  |
| 0001                     | VendorName      | Visible String            | 1 | 32     | R      | Vendor name                | Phoenix Contact                                  |
| 0002                     | VendorID        | Visible String            | 1 | 7      | R      | Vendor ID                  | 00A045                                           |
| 0003                     | VendorText      | Visible String            | 1 | 58     | R      | Vendor text                | Components and systems for industrial automation |
| 0012                     | VendorURL       | Visible String            | 1 | 58     | R      | Vendor URL                 | www.phoenixcontact.com                           |
| <b>Module - general</b>  |                 |                           |   |        |        |                            |                                                  |
| 0004                     | DeviceFamily    | Visible String            | 1 | 16     | R      | Device family              | I/O digital OUT                                  |
| 0006                     | ProductFamily   | Visible String            | 1 | 32     | R      | Product family             | AXL F                                            |
| 000E                     | CommProfile     | Visible String            | 1 | 4      | R      | Communication profile      | 633                                              |
| 000F                     | DeviceProfile   | Visible String            | 1 | 5      | R      | Device profile             | 0010                                             |
| 0011                     | ProfileVersion  | Record of Visible Strings | 2 | 11; 21 | R      | Profile version            | 2011-12-07; Basic - Profile V2.0                 |
| 0017                     | Language        | Record of Visible Strings | 2 | 6; 8   | R      | Language                   | en-us; English                                   |
| 003A                     | VersionCount    | Array of UINT16           | 4 | 4 * 2  | R      | Version counter            | e.g., 0007 0001 0001 0001 <sub>hex</sub>         |
| <b>Module - special</b>  |                 |                           |   |        |        |                            |                                                  |
| 0005                     | Capabilities    | Visible String            | 1 | 8      | R      | Capabilities               | Nothing                                          |
| 0007                     | ProductName     | Visible String            | 1 | 32     | R      | Product name               | AXL F DO16/3 2F                                  |
| 0008                     | SerialNo        | Visible String            | 1 | 22     | R      | Serial number              | e. g., 1234512345                                |
| 0009                     | ProductText     | Visible String            | 1 | 58     | R      | Product text               | 16 digital outputs                               |
| 000A                     | OrderNumber     | Visible String            | 1 | 32     | R      | Order No.                  | 2688048                                          |
| 000B                     | HardwareVersion | Record of Visible Strings | 2 | 11; 11 | R      | Hardware version           | e. g., 2011-02-04; 00                            |
| 000C                     | FirmwareVersion | Record of Visible Strings | 2 | 11; 11 | R      | Firmware version           | e.g., 2017-12-31; 1.00                           |
| 000D                     | PChVersion      | Record of Visible Strings | 2 | 11; 6  | R      | PDI version                | e. g., 2010-06-21; V1.00                         |
| 0037                     | DeviceType      | Octet string              | 1 | 8      | R      | Device type                | 00 40 00 02 00 00 00 D1 <sub>hex</sub>           |
| <b>Use of the device</b> |                 |                           |   |        |        |                            |                                                  |
| 0014                     | Location        | Visible String            | 1 | 59     | R/W    | Location                   | Can be completed by the user.                    |
| 0015                     | EquipmentIdent  | Visible String            | 1 | 59     | R/W    | Equipment identifier       | Can be completed by the user.                    |
| 0016                     | ApplDeviceAddr  | UINT16                    | 1 | 2      | R/W    | Application device address | Can be completed by the user.                    |

## Deviating behavior up to hardware revision 04

| Index (hex)             | Object name     | Data type                 | A | L      | Rights | Meaning          | Contents                                         |
|-------------------------|-----------------|---------------------------|---|--------|--------|------------------|--------------------------------------------------|
| <b>Manufacturer</b>     |                 |                           |   |        |        |                  |                                                  |
| 0001                    | VendorName      | Visible String            | 1 | 16     | R      | Vendor name      | Phoenix Contact                                  |
| 0003                    | VendorText      | Visible String            | 1 | 49     | R      | Vendor text      | Components and systems for industrial automation |
| 0012                    | VendorURL       | Visible String            | 1 | 23     | R      | Vendor URL       | www.phoenixcontact.com                           |
| <b>Module - general</b> |                 |                           |   |        |        |                  |                                                  |
| 0006                    | ProductFamily   | Visible String            | 1 | 6      | R      | Product family   | AXL F                                            |
| 0011                    | ProfileVersion  | Record of Visible Strings | 2 | 11; 20 | R      | Profile version  | 2011-12-07; Basis - Profil V2.0                  |
| 003A                    | VersionCount    | UINT16                    | 4 | 4 * 2  | R      | Version counter  | e.g., 0007 0001 0000 0000 <sub>hex</sub>         |
| <b>Module - special</b> |                 |                           |   |        |        |                  |                                                  |
| 0007                    | ProductName     | Visible String            | 1 | 16     | R      | Product name     | AXL F DO16/3 2F                                  |
| 0008                    | SerialNo        | Visible String            | 1 | 11     | R      | Serial number    | e. g., 1234512345                                |
| 0009                    | ProductText     | Visible String            | 1 | 19     | R      | Product text     | 16 digital outputs                               |
| 000A                    | OrderNumber     | Visible String            | 1 | 8      | R      | Order No.        | 2688048                                          |
| 000B                    | HardwareVersion | Record of Visible Strings | 2 | 11; 3  | R      | Hardware version | e. g., 2011-02-04; 00                            |
| 000C                    | FirmwareVersion | Record of Visible Strings | 2 | 11; 3  | R      | Firmware version | 0000-00-00; --                                   |

## 13.2 Miscellaneous standard objects

| Index (hex)                                | Object name  | Data type        | A | L       | Rights | Meaning/contents                       |   |
|--------------------------------------------|--------------|------------------|---|---------|--------|----------------------------------------|---|
| <b>Diagnostics objects</b>                 |              |                  |   |         |        |                                        |   |
| 0018                                       | DiagState    | Record           | 6 | 58      | R      | Diagnostic state                       | * |
| <b>Objects for process data management</b> |              |                  |   |         |        |                                        |   |
| 0026                                       | PDOOUT       | Octet string     | 1 | 2       | R      | Output process data                    | * |
| 003B                                       | PDIN_Descr   | Array of Records | 3 | 8; 2; 2 | R      | Description of the IN process data     |   |
| 003C                                       | PDOOUT_Descr | Array of Records | 3 | 8; 2; 2 | R      | Description of the output process data |   |

The objects marked in the last column with an \* are described in more detail in the next sections.

The description of the other objects is to be found in the user manual UM EN AXL F SYS INST.

The objects 003B<sub>hex</sub> and 003C<sub>hex</sub> are only applicable to tools.

### 13.3 Diagnostics objects

#### Diagnostics state (0018<sub>hex</sub>: DiagState)

This object is used for a structured message of an error.

#### As of hardware revision 05

| 0018 <sub>hex</sub> : Diagnostics state (read) |                |                 |                      |                                        |
|------------------------------------------------|----------------|-----------------|----------------------|----------------------------------------|
| Subindex                                       | Data type      | Length in bytes | Meaning              | Contents                               |
| 0                                              | Record         | 58              | Diagnostic state     | Complete diagnostics information       |
| 1                                              | UINT16         | 2               | Error number         | 0 ... 65535 <sub>dec</sub>             |
| 2                                              | UINT8          | 1               | Priority             | 00 <sub>hex</sub>   No error           |
|                                                |                |                 |                      | 01 <sub>hex</sub>   Error              |
|                                                |                |                 |                      | 02 <sub>hex</sub>   Warning            |
|                                                |                |                 |                      | 81 <sub>hex</sub>   Error removed      |
|                                                |                |                 |                      | 82 <sub>hex</sub>   Warning eliminated |
| 3                                              | UINT8          | 1               | Channel/group/module | 00 <sub>hex</sub>   No error           |
|                                                |                |                 |                      | 01 <sub>hex</sub>   Channel 1 (OUT1)   |
|                                                |                |                 |                      | ...   ...                              |
|                                                |                |                 |                      | 10 <sub>hex</sub>   Channel 16 (OUT16) |
|                                                |                |                 |                      | FF <sub>hex</sub>   entire device      |
| 4                                              | UINT16         | 2               | Error code           | See table below                        |
| 5                                              | UINT8          | 1               | More follows         | 00 <sub>hex</sub>                      |
| 6                                              | Visible String | 51              | Text                 | See table below                        |



The message with priority 81<sub>hex</sub> or 82<sub>hex</sub> is a one-off, internal message to the bus coupler. The bus coupler transfers this error message to the error mechanisms of the higher-level system.



After all errors have been eliminated, it is automatically reset.

Error and status of the local diagnostics and status indicators

| Subindex                            | 2        | 3                            | 4             | 6                                                  | LED |                |    |    |    |
|-------------------------------------|----------|------------------------------|---------------|----------------------------------------------------|-----|----------------|----|----|----|
|                                     | Priority | Channel/<br>group/<br>module | Error<br>code | Text                                               | D   | U <sub>O</sub> | E1 | E2 | xx |
|                                     | hex      | hex                          | hex           |                                                    |     |                |    |    |    |
| No error                            | 00       | 00                           | 0000          | Status OK                                          | ⓘ   | ●              | ○  | ○  | ○  |
| Short-circuit/overload of an output | 02       | ##                           | 2344          | Overload / short circuit DO##, terminal point \$\$ | ⓘ   | ●              | ○  | ⓘ  | ⓘ  |
| Actuator supply not present         | 01       | FF                           | 3422          | Missing I/O supply UO, terminal point a1/a2, b1/b2 | ⚡   | ○              | ●  | ○  | ○  |

|      |                       |        |                           |
|------|-----------------------|--------|---------------------------|
| ##   | Channel number        | xx LED | Diagnostics of the output |
| \$\$ | Terminal point number | xx     | 00 ... 07, 40 ... 47      |
| ○    | Off                   | ●      | Green on                  |
| ●    | On                    | ⓘ      | Red on                    |
|      |                       | ⚡      | Flashing green/yellow     |



"Actuator supply not present" is then signaled using object 0018<sub>hex</sub> and LED E1 if you have configured a setting stipulating that the error should be sent to the controller (see object FF8F<sub>hex</sub>).

#### Deviating behavior up to hardware revision 04

| 0018 <sub>hex</sub> : Diagnostics state (read) |                |                 |                      |                                      |
|------------------------------------------------|----------------|-----------------|----------------------|--------------------------------------|
| Subindex                                       | Data type      | Length in bytes | Meaning              | Contents                             |
| 0                                              | Record         | 8               | Diagnostic state     | Complete diagnostics information     |
| 1                                              | UINT16         | 2               | Error number         | 0 ... 65535 <sub>dec</sub>           |
| 2                                              | UINT8          | 1               | Priority             | 00 <sub>hex</sub> No error           |
|                                                |                |                 |                      | 01 <sub>hex</sub> Error              |
|                                                |                |                 |                      | 02 <sub>hex</sub> Warning            |
|                                                |                |                 |                      | 81 <sub>hex</sub> Error removed      |
|                                                |                |                 |                      | 82 <sub>hex</sub> Warning eliminated |
| 3                                              | UINT8          | 1               | Channel/group/module | 00 <sub>hex</sub> No error           |
|                                                |                |                 |                      | FF <sub>hex</sub> entire device      |
| 4                                              | UINT16         | 2               | Error code           | See table below                      |
| 5                                              | UINT8          | 1               | More follows         | 00 <sub>hex</sub>                    |
| 6                                              | Visible String | 1               | Text                 | 00 <sub>hex</sub>                    |

#### Error and status of the local diagnostics and status indicators

| Subindex                            | 2        | 3                    | 4          | LED    |                |    |    |
|-------------------------------------|----------|----------------------|------------|--------|----------------|----|----|
|                                     | Priority | Channel/group/module | Error code | D      | U <sub>0</sub> | E1 | xx |
| Error                               | hex      | hex                  | hex        |        |                |    |    |
| No error                            | 00       | 00                   | 0000       | ●      | ●              | ○  | ○  |
| Short-circuit/overload of an output | 02       | 00                   | 2344       | ●      | ●              | ●  | ●  |
| Actuator supply not present         | 01       | FF                   | 3422       | ● or ✨ | ○              | ○  | ○  |

xx LED          Diagnostics of the output

xx                00 ... 03, 10 ... 13, 20 ... 23, 30 ... 33

○                Off

●                On

●                Green on

●                Red on

✨                Flashing green/yellow

The behavior of LED D during an "Actuator supply not present" error depends on whether you have switched error reporting via the FF8F<sub>hex</sub> object on or off.

| Parameterization in FF8F <sub>hex</sub> | D LED |
|-----------------------------------------|-------|
| Do not report error to the controller   | ●     |
| Report error to the controller          | ✨     |

### 13.4 Objects for process data management

#### OUT process data (0026<sub>hex</sub>: PDOUT)

You can read the OUT process data of the module with this object.

The structure corresponds to the representation in the "Process data" section.

| 0026 <sub>hex</sub> : OUT process data (read) |              |                 |                     |
|-----------------------------------------------|--------------|-----------------|---------------------|
| Subindex                                      | Data type    | Length in bytes | Meaning             |
| 0                                             | Octet string | 2               | Output process data |

## 14 Application objects

In the case of valid parameters, the parameterization is stored in the module permanently.

| Index (hex) | Object name                        | Data type | A | L | Rights | Meaning/contents                      |
|-------------|------------------------------------|-----------|---|---|--------|---------------------------------------|
| FF8D        | PD Output Substitute Configuration | UINT8     | 1 | 1 | R/W    | Substitute value behavior             |
| FF8F        | DiagOut                            | UINT8     | 1 | 1 | R/W    | Message "Actuator supply not present" |

#### 14.1 Substitute value behavior (FF8D<sub>hex</sub>: PD Output Substitute Configuration)

With this object, you parameterize the behavior of the module so that an application reset can be detected if necessary.

| FF8D <sub>hex</sub> : Substitute value behavior (read, write) |           |                 |                             |                  |
|---------------------------------------------------------------|-----------|-----------------|-----------------------------|------------------|
| Subindex                                                      | Data type | Length in bytes | Contents                    |                  |
| 0                                                             | Var       | 1               | 00 <sub>hex</sub> (Default) | Set outputs to 0 |
|                                                               |           |                 | 01 <sub>hex</sub>           | Hold last value  |

#### 14.2 Message "Actuator supply not present" (FF8F<sub>hex</sub>: DiagOut)

With this object, you parameterize whether the "Actuator supply missing" error is reported to the controller or not.

| FF8F <sub>hex</sub> : Message "Actuator supply not present" (Read, write) |           |                 |                             |                                       |
|---------------------------------------------------------------------------|-----------|-----------------|-----------------------------|---------------------------------------|
| Subindex                                                                  | Data type | Length in bytes | Contents                    |                                       |
| 0                                                                         | Var       | 1               | 00 <sub>hex</sub> (Default) | Do not report error to the controller |
|                                                                           |           |                 | 01 <sub>hex</sub>           | Report error to the controller        |

#### As of hardware revision 05

If you parameterize the module so that the error is not reported to the controller, the corresponding indicator in LED E1 (red on) is suppressed. The behavior of the LED D is not affected.

#### Deviating behavior up to hardware revision 04

If you parameterize the module so that the error is not reported to the controller, the corresponding indicator in LED D (flashing green/yellow) is suppressed and the LED lights up green.

## 15 Device descriptions

The device is described in the device description files.

The device descriptions for controllers from Phoenix Contact are included in PC Worx and the corresponding service packs.

The device description files for other systems are available for download at [phoenixcontact.net/products](http://phoenixcontact.net/products) in the download area of the bus coupler used.



# SCATTERGOOD & JOHNSON LTD

ELECTRICAL ENGINEERING & FLUID CONTROL DISTRIBUTORS

Est.1899

At Scattergood & Johnson Ltd, we pride ourselves on being a technical distributor to specialist industries.

Working with a range of quality product suppliers across a number of specialist markets, we are not your average 'box shifter' - we are your technical and supply chain partner.

We fully support every product we sell - for free! Our internal team and external sales engineers can answer any product or application question, no matter the complexity.

Backing up this technical ability is a range of 50,000+ products available from stock for nationwide next day delivery (same day if required!), or you can collect what you need from any of our trade counters around the UK.

Select your specialist interest below to learn more about how we can help.



Online, In Branch and On the Road - Scattergood & Johnson Ltd, there when you need us.

# [www.scatts.co.uk](http://www.scatts.co.uk)