

# AXL F DO32/1 1F

**Axioline F, digital output module,  
digital outputs: 32, 24 V DC, 500 mA,  
connection method: 1-wire**

Data sheet  
8124\_en\_02

© PHOENIX CONTACT 2018-10-12



## 1 Description

The module is designed for use within an Axioline F station. It is used to output digital signals. The outputs are protected against short circuit and overload.

### Features

- 32 digital outputs
- 24 V DC, 500 mA
- Connection of actuators in single-wire technology
- Minimum update time of < 100 µs
- Device rating plate stored

**Valid for hardware Version 05, firmware Version 1.00 or later.**



The deviating behavior of the modules with an earlier hardware revision is documented in the corresponding points.



This data sheet is only valid in association with the UM EN AXL F SYS INST user manual.



Make sure you always use the latest documentation. It can be downloaded at: [phoenixcontact.net/product/2688051](https://phoenixcontact.net/product/2688051)

---

<b>2</b>	<b>Table of contents</b>	
1	Description .....	1
2	Table of contents .....	2
3	Ordering data .....	3
4	Technical data .....	4
5	Maximum outputs power consumption when inductive loads are switched off .....	8
6	Internal circuit diagram .....	8
7	Terminal point assignment.....	9
8	Connection example.....	9
9	Local diagnostic and status indicators .....	10
10	Process data.....	11
11	Parameter, diagnostics and information (PDI) .....	11
12	Standard objects .....	12
	12.1 Objects for identification (device rating plate).....	12
	12.2 Miscellaneous standard objects .....	13
	12.3 Diagnostics objects .....	14
	12.4 Objects for process data management.....	16
13	Application objects .....	16
	13.1 Substitute value behavior (FF8Dhex: PD Output Substitute Configuration) .....	16
	13.2 Message "Actuator supply not present" (FF8Fhex: DiagOut).....	16
14	Device descriptions .....	17

### 3 Ordering data

Description	Type	Order No.	Pcs./Pkt.
Axioline F, Digital output module, digital outputs: 32, 24 V DC, 500 mA, connection method: 1-wire, transmission speed in the local bus: 100 Mbps, degree of protection: IP20, including bus base module and Axioline F connectors	AXL F DO32/1 1F	2688051	1
<b>Accessories</b>	<b>Type</b>	<b>Order No.</b>	<b>Pcs./Pkt.</b>
Axioline F bus base module for housing type F (Replacement item)	AXL F BS F	2688129	5
Zack marker strip for Axioline F (device labeling), in 2 x 20.3 mm pitch, unprinted, 25-section, for individual labeling with B-STIFT 0.8, X-PEN, or CMS-P1-PLOTTER (Marking)	ZB 20,3 AXL UNPRINTED	0829579	25
Zack marker strip, flat, in 10 mm pitch, unprinted, 10-section, for individual labeling with M-PEN 0,8, X-PEN, or CMS-P1-PLOTTER (Marking)	ZBF 10/5,8 AXL UNPRINTED	0829580	50
Insert label, for the Axioline F series from Phoenix Contact, Roll, white, unlabeled, can be labeled with: THERMOMARK ROLL 2.0, THERMOMARK ROLL, THERMOMARK ROLL X1, THERMOMARK ROLLMASTER 300/600, THERMOMARK X1.2, mounting type: snapped into marker carrier, lettering field size: 35 x 46 mm (Marking)	EMT (35X46)R	0801604	1
V8 adapter for 8 x PLC-INTERFACE (6.2 mm); Controller: PLC system cabling of output cards; connection 1: Plug connection (Can be snapped onto 8x PLC-INTERFACE terminals); connection 2: 1x IDC/FLK pin strip (14-position); number of channels: 8; control logic: positive switching (Connector/Adapter)	PLC-V8/FLK14/OUT	2295554	1
V8 adapter for 8 x PLC-INTERFACE (14 mm); Controller: PLC system cabling of output cards; connection 1: Plug connection (Can be snapped onto 8x PLC-INTERFACE terminals); connection 2: 1x IDC/FLK pin strip (14-position); number of channels: 8; control logic: positive switching (Connector/Adapter)	PLC-V8L/FLK14/OUT	2299660	1
VARIOFACE module, with screw connection and flat-ribbon cable connector, for mounting on NS 35 rails, with pin strip and short and long locking latches for socket strips, 20-pos.	VIP-2/SC/FLK20	2315049	1
VARIOFACE module, with screw connection and flat-ribbon cable connector, for mounting on NS 35 rails, with pin strip and short and long locking latches for socket strips, 20-pos., with LED	VIP-2/SC/FLK20/LED	2322074	1

Accessories	Type	Order No.	Pcs./Pkt.
VARIOFACE module, with push-in connections and flat-ribbon cable connector, for mounting on NS 35 rails, with pin strip and short and long locking latches for socket strips, 20-pos.	VIP-2/PT/FLK20	2903790	1
VARIOFACE module, with push-in connection and flat-ribbon cable connector, for mounting on NS 35 rails, with pin strip and short and long locking latches for socket strips, 20-pos., with LED	VIP-2/PT/FLK20/LED	2904251	1
VARIOFACE SLIM LINE, with screw connection and flat-ribbon cable connector, for assembly at a right angle on NS 35/7.5, 20 positions	UM 25-FLK20/FRONT/Q	2959515	1

Documentation	Type	Order No.	Pcs./Pkt.
User manual, English, Axioline F: System and installation	UM EN AXL F SYS INST	-	-
User manual, English, Axioline F: Diagnostic registers, and error messages	UM EN AXL F SYS DIAG	-	-

## 4 Technical data

### Dimensions (nominal sizes in mm)

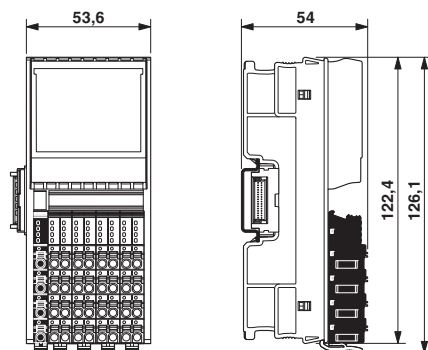

Width	53.6 mm
Height	126.1 mm
Depth	54 mm
Note on dimensions	The depth is valid when a TH 35-7,5 DIN rail is used (according to EN 60715).

General data	
Color	traffic grey A RAL 7042
Weight	191 g (with connectors and bus base module)
Ambient temperature (operation)	-25 °C ... 60 °C
Ambient temperature (storage/transport)	-40 °C ... 85 °C
Permissible humidity (operation)	5 % ... 95 % (non-condensing)
Permissible humidity (storage/transport)	5 % ... 95 % (non-condensing)
Air pressure (operation)	70 kPa ... 106 kPa (up to 3000 m above sea level)
Air pressure (storage/transport)	70 kPa ... 106 kPa (up to 3000 m above sea level)
Degree of protection	IP20
Protection class	III, IEC 61140, EN 61140, VDE 0140-1
Mounting position	any (no temperature derating)

Connection data: Axioline F connector	
Connection method	Push-in connection
Conductor cross section solid / stranded	0.2 mm <sup>2</sup> ... 1.5 mm <sup>2</sup> / 0.2 mm <sup>2</sup> ... 1.5 mm <sup>2</sup>
Conductor cross section [AWG]	24 ... 16
Stripping length	8 mm



Please observe the information provided on conductor cross sections in the "Axioline F: system and installation" user manual.

Interface: Axioline F local bus	
Number	2
Connection method	Bus base module
Transmission speed	100 Mbps

Axioline F local bus supply ( $U_{Bus}$ )	
Supply voltage	5 V DC (via bus base module)
Current draw	max. 120 mA (up to HW 04) max. 60 mA (from HW 05)
Power consumption	max. 600 mW (up to HW 04) max. 300 mW (from HW 05)

Supply for digital output modules ( $U_O$ )	
Supply voltage	24 V DC
Supply voltage range	19.2 V DC ... 30 V DC (including all tolerances, including ripple)
Current draw	min. 35 mA (without actuators) max. 8 A (up to HW 04, provide external protection) max. 16 A (from HW 05, provide external protection; if the total current of 8 A is exceeded, connect the supply at the power connector parallel via both terminal points.)
Power consumption	typ. 800 mW (without actuators) max. 240 W (up to HW 04, of which 1.5 W constitute internal losses) max. 480 W (from HW 05, of which max. 2.4 W constitute internal losses)

**Supply for digital output modules (U<sub>0</sub>)**

Surge protection of the supply voltage	electronic (35 V, 0.5 s)
Polarity reversal protection of the supply voltage	parallel diode; with external 5 A fuse (only for commissioning)
Protection	max. 8 A (up to HW 04, protection against polarity reversal up to 5 A) max. 16 A (form HW 05, protection against polarity reversal up to 5 A)

**NOTE: Damage to the electronics**

Provide external protection for the module to protect it against polarity reversal. If you are using an external fuse, the power supply unit must be able to supply four times the nominal current of the fuse. This ensures that it trips in the event of an error.

**Up to hardware revision 04:**

When using the module for the first time, protect it with a 5 A fuse. When all modules in the system are correctly connected, the 5 A fuse can be replaced with an 8 A fuse. After that, you can load the module up to 8 A.

Loads over 8 A are not permitted.

**As of hardware revision 05:**

When using the module for the first time, protect it with a 5 A fuse. When all modules in the system are correctly connected, the 5 A fuse can be replaced with a 16 A fuse. After that, you can load the module up to 16 A.

Loads over 16 A are not permitted.

**Digital outputs**

Number of outputs	32
Connection method	Push-in connection
Connection technology	1-wire
Nominal output voltage	24 V DC
Maximum output current per channel	500 mA
Maximum output current per device	8 A (up to HW 04, provide external protection) 16 A (from HW 05, provide external protection)
Nominal load, ohmic	max. 12 W (48 Ω, with nominal voltage)
Nominal load, inductive	max. 12 VA (1.2 H, 48 Ω, with nominal voltage)
Nominal load, lamp	max. 12 W (at nominal voltage)
Signal delay	max. 150 μs (when switched on) max. 200 μs (during switching off with ohmic nominal load)
Switching frequency	max. 5500 per second (with ohmic load) max. 1 per second (with inductive load) max. 16 per second (with nominal lamp load)
Load min.	10 kΩ
Energy consumption	see diagram
Limitation of the voltage induced on circuit interruption	-32.8 V ... -15 V
Output voltage when switched off	max. 1 V
Output current when switched off	max. 300 μA
Behavior with overload	Shutdown with automatic restart
Behavior with inductive overload	Output can be destroyed
Reverse voltage resistance to short pulses	limited protection up to 0.5 A for 1 s

**Digital outputs****NOTE: Damage to the electronics**

If there is a faulty external voltage (reverse voltage) at one of the outputs, the output may be destroyed. This may cause unintentional setting of further outputs.

Overcurrent shut-down	as of 0.7 A
Output current with ground connection interrupt when switched off	< 1 mA
Short-circuit protection, overload protection of the outputs	electronic

**Input and output address area**

Input address area	0 Byte
Output address area	4 Byte

**Configuration and parameter data in a PROFIBUS system**

Required parameter data	1 Byte
Required configuration data	6 Byte

**Electrical isolation/isolation of the voltage areas**

Test section	Test voltage
5 V communications power (logic), 24 V supply (I/O)	500 V AC, 50 Hz, 1 min.
5 V supply (logic)/functional earth ground	500 V AC, 50 Hz, 1 min.
24 V supply (I/O) / functional earth ground	500 V AC, 50 Hz, 1 min.

**Mechanical tests**

Vibration resistance in acc. with EN 60068-2-6/ IEC 60068-2-6	5g
Shock in acc. with EN 60068-2-27/IEC 60068-2-27	30g
Continuous shock according to EN 60068-2-27/ IEC 60068-2-27	10g

**Conformance with EMC Directive 2014/30/EU****Noise immunity test in accordance with EN 61000-6-2**

Electrostatic discharge (ESD) EN 61000-4-2/ IEC 61000-4-2	Criterion B, 6 kV contact discharge, 8 kV air discharge
Electromagnetic fields EN 61000-4-3/IEC 61000-4-3	Criterion A, Field intensity: 10 V/m
Fast transients (burst) EN 61000-4-4/IEC 61000-4-4	Criterion B, 2 kV
Transient overvoltage (surge) EN 61000-4-5/ IEC 61000-4-5	Criterion B, DC supply lines: $\pm 0.5$ kV/ $\pm 0.5$ kV (symmetrical/ asymmetrical)
Conducted interference EN 61000-4-6/IEC 61000-4-6	Criterion A; Test voltage 10 V

**Noise emission test according to EN 61000-6-3** Class B

**Approvals**

For the latest approvals, please visit [phoenixcontact.net/products](http://phoenixcontact.net/products).

### 5 Maximum outputs power consumption when inductive loads are switched off



**NOTE: Damage to the electronics**  
 When you use an external freewheel limit, the free-wheeling voltage to a maximum of -15 V. The value **must** be above -15 V, so -12 V, for example.  
 The external freewheel limit has no function with a higher negative voltage.

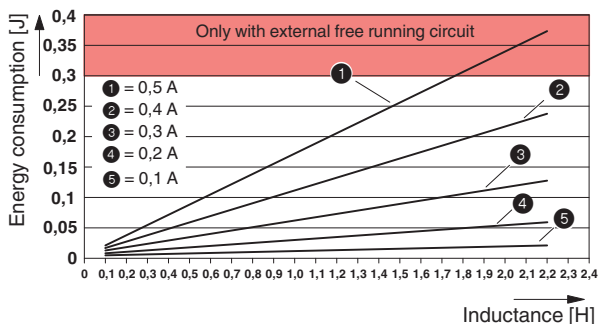

Figure 1 Maximum outputs power consumption when inductive loads are switched off

The specifications in the diagram refer to a maximum switching frequency of 1 Hz.  
 The diagram displays the maximum amount of energy that may be fed back into the the corresponding output groups (outputs 1 to 8, 9 to 16, 17 to 24, 25 to 32) for each switch off procedure during switching off of an inductive load without external freewheeling circuit.  
 The current data refers to the ohmic DC voltage component of the inductive load.

### 6 Internal circuit diagram

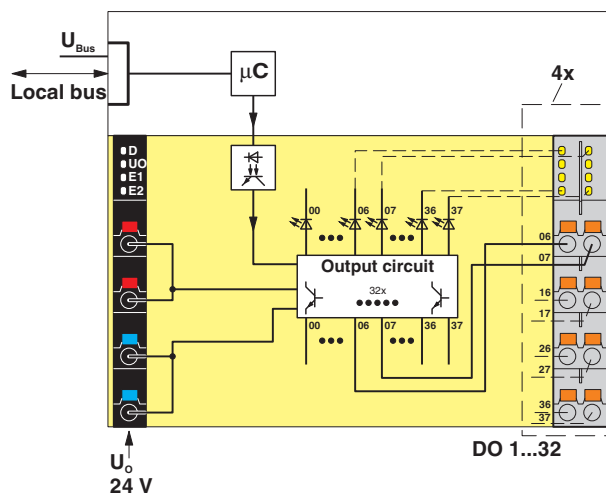

Figure 2 Internal wiring of the terminal points

Key:

- Local bus
- Microcontroller
- Optocoupler
- LED
- Electrically isolated areas
- Output configuration

### 7 Terminal point assignment

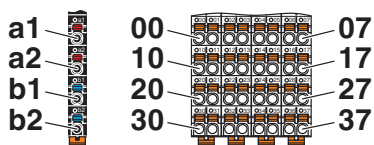

Figure 3 Terminal point assignment

Terminal point	Color	Assignment	
<b>Supply voltage input</b>			
a1, a2	Red	24 V DC (U <sub>O</sub> )	Supply for digital output modules (internally jumpered)
b1, b2	Blue	GND	Reference potential of the supply voltage (bridged internally)
<b>Digital outputs</b>			
00 ... 07	Orange	OUT01 ... OUT08	Digital outputs 1 ... 8
10 ... 17	Orange	OUT09 ... OUT16	Digital outputs 9 ... 16
20 ... 27	Orange	OUT17 ... OUT24	Digital outputs 17 ... 24
30 ... 37	Orange	OUT25 ... OUT32	Digital outputs 25 ... 32

### 8 Connection example

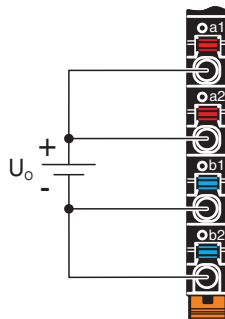

Figure 4 Parallel supply of the supply voltage

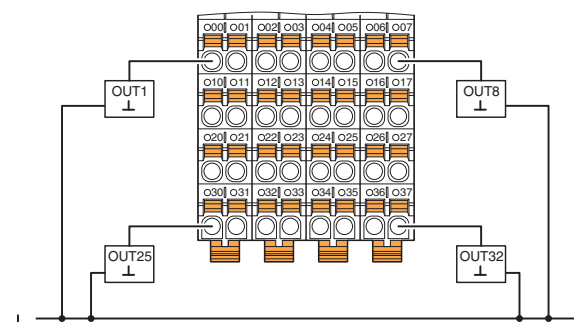
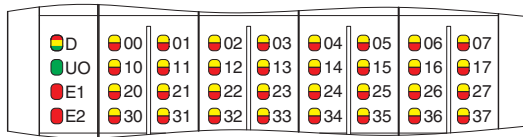

Figure 5 Connection with 1-wire technology

Make sure that the GND of the actuators and the GND for U<sub>O</sub> have the same potential!

## 9 Local diagnostic and status indicators

As of hardware revision 05



Channel errors are errors that can be associated with a channel.  
Periphery errors are errors that affect the entire module.

Figure 6 Local diagnostic and status indicators

Designation	Color	Meaning	State	Description
D	Red/ yellow/ green	Diagnostics of local bus communication		
		Run	Green on	The device is ready for operation, communication within the station is OK. All data is valid. An error has not occurred.
		Active	Green flashing	The device is ready for operation, communication within the station is OK. The data is <b>not</b> valid. No valid data provided by the controller/higher-level network. There is no error on the module.
		Device application not active	Flashing green/yellow	The device is ready for operation, communication within the station is OK. Output data <b>cannot</b> be outputted and/or input data <b>cannot</b> be read. There is a fault on the periphery side of the module..
		Ready	Yellow on	The device is ready for operation but did not detect a valid cycle after power-up.
		Connected	Yellow flashing	The device is not (yet) part of the active configuration.
		Reset	Red on	The device is ready for operation but has lost the connection to the bus head.
		Not connected	Flashing red	The device is ready for operation but there is no connection to the previously existing device.
Power down	OFF	Device is in (power) reset.		
U <sub>O</sub>	Green	U <sub>Output</sub>	On	Supply for digital output modules present.
			OFF	Supply for digital output modules is not present.
E1	Red	Peripheral fault	On	I/O error present.
			OFF	No I/O error.
E2	Red	Channel error	On	Channel error present.
			OFF	Channel error not present.
00 ... 37	Red/ yellow	Diagnostics / Status of the outputs	Red on	Short-circuit/overload of the output.
			Yellow on	Output is set.
			OFF	No error, output is not set.

**Deviating behavior up to hardware revision 04**

The LED E2 is not present.

Designation	Color	Meaning	State	Description
E1	Red	Peripheral fault	On	Breakdown or overload/short-circuit of an output.
			OFF	No I/O error.

**10 Process data**

I/O data is mapped in the Motorola format.

**OUT process data**

Byte	0							
Bit	7	6	5	4	3	2	1	0
Signal	OUT 08	OUT 07	OUT 06	OUT 05	OUT 04	OUT 03	OUT 02	OUT 01
Terminal point	07	06	05	04	03	02	01	00

Byte	1							
Bit	7	6	5	4	3	2	1	0
Signal	OUT 16	OUT 15	OUT 14	OUT 13	OUT 12	OUT 11	OUT 10	OUT 09
Terminal point	17	16	15	14	13	12	11	10

Byte	2							
Bit	7	6	5	4	3	2	1	0
Signal	OUT 24	OUT 23	OUT 22	OUT 21	OUT 20	OUT 19	OUT 18	OUT 17
Terminal point	27	26	25	24	23	22	21	20

Byte	3							
Bit	7	6	5	4	3	2	1	0
Signal	OUT 32	OUT 31	OUT 30	OUT 29	OUT 28	OUT 27	OUT 26	OUT 25
Terminal point	37	36	35	34	33	32	31	30

**11 Parameter, diagnostics and information (PDI)**

Parameter and diagnostic data as well as other information is transmitted as objects via the PDI channel of the Axioline F station.

The standard and application objects stored in the module are described in the following section.

The following applies to all tables below:

Please refer to the UM EN AXL F SYS INST for an explanation of the data types.

Abbreviation	Meaning
A	Number of elements
L	Length of the elements in bytes
R	Read
W	Write



Each visible string is terminated with a null terminator (00<sub>hex</sub>). The length of a visible-string-type element is therefore at least one byte larger than the number of user data items.  
If the number of user data items plus null terminator is smaller than the specified length of the element, the visible string will be populated with a null character (00<sub>hex</sub>).



For detailed information on PDI objects, please refer to the UM EN AXL F SYS INST user manual.

## 12 Standard objects

### 12.1 Objects for identification (device rating plate)

As of hardware revision 05

Index (hex)	Object name	Data type	A	L	Rights	Meaning	Contents
<b>Manufacturer</b>							
0001	VendorName	Visible String	1	32	R	Vendor name	Phoenix Contact
0002	VendorID	Visible String	1	7	R	Vendor ID	00A045
0003	VendorText	Visible String	1	58	R	Vendor text	Components and systems for industrial automation
0012	VendorURL	Visible String	1	58	R	Vendor URL	www.phoenixcontact.com
<b>Module - general</b>							
0004	DeviceFamily	Visible String	1	16	R	Device family	I/O digital OUT
0006	ProductFamily	Visible String	1	32	R	Product family	AXL F
000E	CommProfile	Visible String	1	4	R	Communication profile	633
000F	DeviceProfile	Visible String	1	5	R	Device profile	0010
0011	ProfileVersion	Record of Visible Strings	2	11; 21	R	Profile version	2011-12-07; Basic - Profile V2.0
0017	Language	Record of Visible Strings	2	6; 8	R	Language	en-us; English
003A	VersionCount	Array of UINT16	4	4 * 2	R	Version counter	e.g., 0007 0001 0001 0001 <sub>hex</sub>
<b>Module - special</b>							
0005	Capabilities	Visible String	1	8	R	Capabilities	Nothing
0007	ProductName	Visible String	1	32	R	Product name	AXL F DO32/1 1F
0008	SerialNo	Visible String	1	22	R	Serial number	e. g., 1234512345
0009	ProductText	Visible String	1	58	R	Product text	32 digital outputs
000A	OrderNumber	Visible String	1	32	R	Order No.	2688051
000B	HardwareVersion	Record of Visible Strings	2	11; 11	R	Hardware version	e. g., 2011-02-04; 00
000C	FirmwareVersion	Record of Visible Strings	2	11; 11	R	Firmware version	e.g., 2017-12-31; 1.00
000D	PChVersion	Record of Visible Strings	2	11; 6	R	PDI version	e. g., 2010-06-21; V1.00
0037	DeviceType	Octet string	1	8	R	Device type	00 40 00 04 00 00 00 D3 <sub>hex</sub>
<b>Use of the device</b>							
0014	Location	Visible String	1	59	R/W	Location	Can be completed by the user.
0015	EquipmentIdent	Visible String	1	59	R/W	Equipment identifier	Can be completed by the user.
0016	ApplDeviceAddr	UINT16	1	2	R/W	Application device address	Can be completed by the user.

## Deviating behavior up to hardware revision 04

Index (hex)	Object name	Data type	A	L	Rights	Meaning	Contents
<b>Manufacturer</b>							
0001	VendorName	Visible String	1	16	R	Vendor name	Phoenix Contact
0003	VendorText	Visible String	1	49	R	Vendor text	Components and systems for industrial automation
0012	VendorURL	Visible String	1	23	R	Vendor URL	www.phoenixcontact.com
<b>Module - general</b>							
0006	ProductFamily	Visible String	1	6	R	Product family	AXL F
0011	ProfileVersion	Record of Visible Strings	2	11; 20	R	Profile version	2011-12-07; Basis - Profil V2.0
003A	VersionCount	UINT16	4	4 * 2	R	Version counter	e.g., 0007 0001 0000 0000 <sub>hex</sub>
<b>Module - special</b>							
0007	ProductName	Visible String	1	16	R	Product name	AXL F DO32/1 1F
0008	SerialNo	Visible String	1	11	R	Serial number	e. g., 1234512345
0009	ProductText	Visible String	1	19	R	Product text	32 digital outputs
000A	OrderNumber	Visible String	1	8	R	Order No.	2688051
000B	HardwareVersion	Record of Visible Strings	2	11; 3	R	Hardware version	e. g., 2011-02-04; 00
000C	FirmwareVersion	Record of Visible Strings	2	11; 3	R	Firmware version	0000-00-00; --

## 12.2 Miscellaneous standard objects

Index (hex)	Object name	Data type	A	L	Rights	Meaning/contents	
<b>Diagnostics objects</b>							
0018	DiagState	Record	6	58	R	Diagnostic state	*
<b>Objects for process data management</b>							
0026	PDOOUT	Octet string	1	4	R	Output process data	*
003B	PDIN_Descr	Array of Records	3	8; 2; 2	R	Description of the IN process data	
003C	PDOOUT_Descr	Array of Records	3	8; 2; 2	R	Description of the output process data	

The objects marked in the last column with an \* are described in more detail in the next sections.

The description of the other objects is to be found in the user manual UM EN AXL F SYS INST.

The objects 003B<sub>hex</sub> and 003C<sub>hex</sub> are only applicable to tools.



## Deviating behavior up to hardware revision 04

0018 <sub>hex</sub> : Diagnostics state (read)					
Subindex	Data type	Length in bytes	Meaning	Contents	
0	Record	8	Diagnostic state	Complete diagnostics information	
1	UINT16	2	Error number	0 ... 65535 <sub>dec</sub>	
2	UINT8	1	Priority	00 <sub>hex</sub>	No error
				01 <sub>hex</sub>	Error
				02 <sub>hex</sub>	Warning
				81 <sub>hex</sub>	Error removed
				82 <sub>hex</sub>	Warning eliminated
3	UINT8	1	Channel/group/module	00 <sub>hex</sub>	No error
				FF <sub>hex</sub>	entire device
4	UINT16	2	Error code	See table below	
5	UINT8	1	More follows	00 <sub>hex</sub>	
6	Visible String	1	Text	00 <sub>hex</sub>	

Error and status of the local diagnostics and status indicators

Subindex	2	3	4				
Error	Priority	Channel/ group/ module	Error code	LED			
	hex	hex	hex	D	U <sub>0</sub>	E1	xx
No error	00	00	0000	green on	on	off	off
Short-circuit/overload of an output	02	00	2344	green on	on	red on	red on
Actuator supply not present	01	FF	3422	green on or flashing green/yellow	off	off	off

xx LED                   Diagnostics of the output  
xx                         00 ... 07, 10 ... 17, 20 ... 27, 30 ... 37

The behavior of LED D during an "Actuator supply not present" error depends on whether you have switched error reporting via the FF8F<sub>hex</sub> object on or off.

Parameterization in FF8F <sub>hex</sub>	D LED
Do not report error to the controller	green
Report error to the controller	flashing green/yellow

## 12.4 Objects for process data management

### OUT process data (0026<sub>hex</sub>: PDOUT)

You can read the OUT process data of the module with this object.

The structure corresponds to the representation in the "Process data" section.

0026 <sub>hex</sub> : OUT process data (read)			
Subindex	Data type	Length in bytes	Meaning
0	Octet string	4	Output process data

## 13 Application objects

In the case of valid parameters, the parameterization is stored in the module permanently.

Index (hex)	Object name	Data type	A	L	Rights	Meaning/contents
FF8D	PD Output Substitute Configuration	UINT8	1	1	R/W	Substitute value behavior
FF8F	DiagOut	UINT8	1	1	R/W	Message "Actuator supply not present"

### 13.1 Substitute value behavior (FF8D<sub>hex</sub>: PD Output Substitute Configuration)

With this object, you parameterize the behavior of the module so that an application reset can be detected if necessary.

FF8D <sub>hex</sub> : Substitute value behavior (read, write)				
Subindex	Data type	Length in bytes	Contents	
0	Var	1	00 <sub>hex</sub> (Default)	Set outputs to 0
			01 <sub>hex</sub>	Hold last value

### 13.2 Message "Actuator supply not present" (FF8F<sub>hex</sub>: DiagOut)

With this object, you parameterize whether the "Actuator supply missing" error is reported to the controller or not.

FF8F <sub>hex</sub> : Message "Actuator supply not present" (Read, write)				
Subindex	Data type	Length in bytes	Contents	
0	Var	1	00 <sub>hex</sub> (Default)	Do not report error to the controller
			01 <sub>hex</sub>	Report error to the controller

#### As of hardware revision 05

If you parameterize the module so that the error is not reported to the controller, the corresponding indicator in LED E1 (red on) is suppressed. The behavior of the LED D is not affected.

#### Deviating behavior up to hardware revision 04

If you parameterize the module so that the error is not reported to the controller, the corresponding indicator in LED D (flashing green/yellow) is suppressed and the LED lights up green.

## 14 Device descriptions

The device is described in the device description files.

The device descriptions for controllers from Phoenix Contact are included in PC Worx and the corresponding service packs.

The device description files for other systems are available for download at [phoenixcontact.net/products](http://phoenixcontact.net/products) in the download area of the bus coupler used.



# SCATTERGOOD & JOHNSON LTD

ELECTRICAL ENGINEERING & FLUID CONTROL DISTRIBUTORS

Est.1899

At Scattergood & Johnson Ltd, we pride ourselves on being a technical distributor to specialist industries.

Working with a range of quality product suppliers across a number of specialist markets, we are not your average 'box shifter' - we are your technical and supply chain partner.

We fully support every product we sell - for free! Our internal team and external sales engineers can answer any product or application question, no matter the complexity.

Backing up this technical ability is a range of 50,000+ products available from stock for nationwide next day delivery (same day if required!), or you can collect what you need from any of our trade counters around the UK.

Select your specialist interest below to learn more about how we can help.

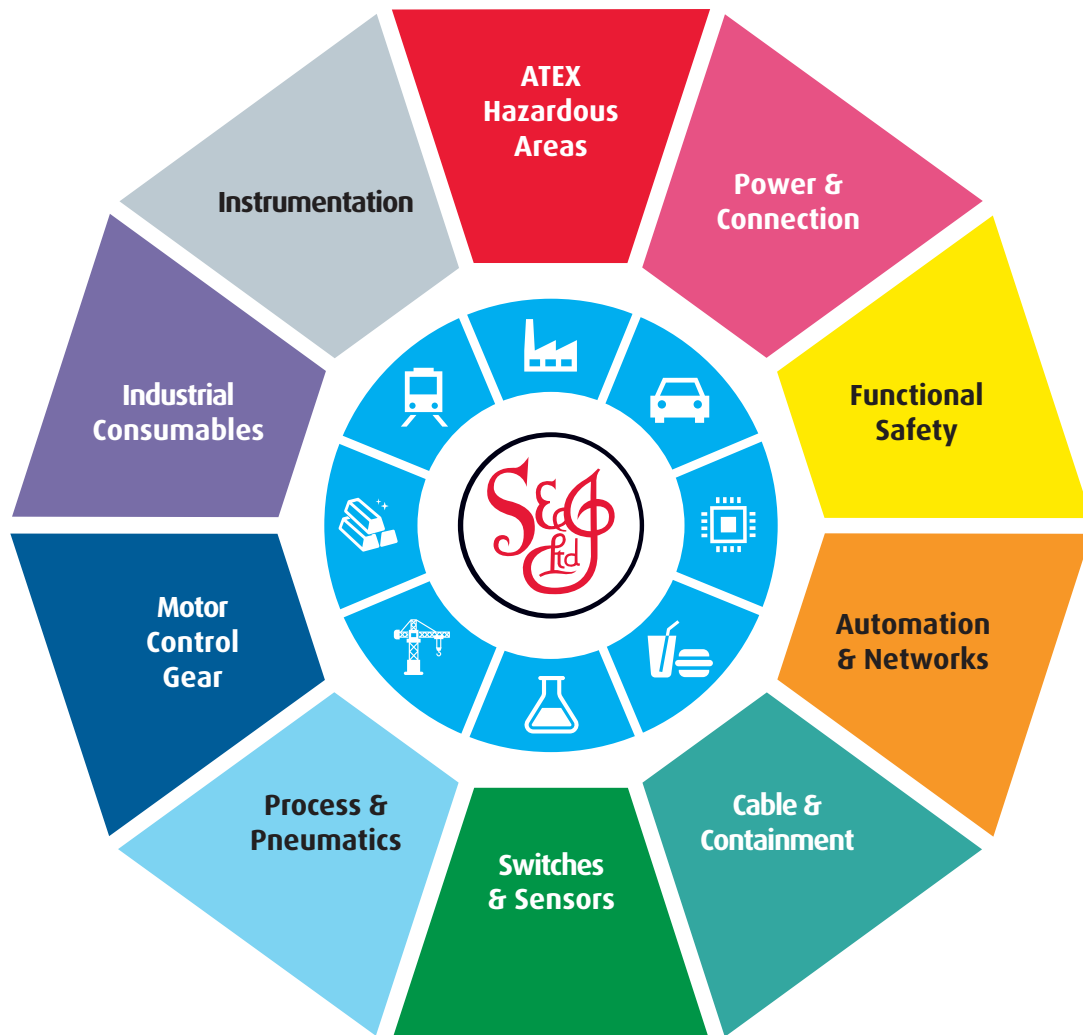

Online, In Branch and On the Road - Scattergood & Johnson Ltd, there when you need us.

# [www.scatts.co.uk](http://www.scatts.co.uk)