

AXL F DO16/1 1H

**Axioline F, digital output module,
digital outputs: 16, 24 V DC, 500 mA,
connection method: 1-wire**

Data sheet
8186_en_04

© PHOENIX CONTACT 2019-01-17



1 Description

The module is designed for use within an Axioline F station. It is used to output digital signals. The outputs are protected against short circuit and overload.

Features

- 16 digital outputs
- 24 V DC, 500 mA
- Connection of actuators in single-wire technology
- Minimum update time of < 100 µs
- Device rating plate stored

Valid for hardware Version 03, firmware Version 1.00 or later.



The deviating behavior of the modules with an earlier hardware revision is documented in the corresponding points.



This data sheet is only valid in association with the UM EN AXL F SYS INST user manual.



Make sure you always use the latest documentation. It can be downloaded at: phoenixcontact.net/product/2688349

2	Table of contents	
1	Description	1
2	Table of contents	2
3	Ordering data	3
4	Technical data	4
5	Maximum outputs power consumption when inductive loads are switched off	8
6	Internal circuit diagram	8
7	Terminal point assignment.....	9
8	Connection example.....	9
9	Local diagnostic and status indicators	10
10	Process data.....	12
11	Parameter, diagnostics and information (PDI)	12
12	Standard objects	13
	12.1 Objects for identification (device rating plate).....	13
	12.2 Miscellaneous standard objects	14
	12.3 Diagnostics objects	15
	12.4 Objects for process data management.....	17
13	Application objects	17
	13.1 Substitute value behavior (FF8Dhex: PD Output Substitute Configuration)	17
	13.2 Message "Actuator supply not present" (FF8Fhex: DiagOut).....	17
14	Device descriptions	18

3 Ordering data

Description	Type	Order No.	Pcs./Pkt.
Axioline F, digital output module, digital outputs: 16, 24 V DC, 500 mA, connection method: 1-wire, transmission speed in the local bus: 100 Mbps, degree of protection: IP20, including bus base module and Axioline F connectors	AXL F DO16/1 1H	2688349	1
Accessories	Type	Order No.	Pcs./Pkt.
Axioline F bus base module for housing type H (Replacement item)	AXL F BS H	2700992	5
Zack marker strip for Axioline F (device labeling), in 2 x 20.3 mm pitch, unprinted, 25-section, for individual labeling with B-STIFT 0.8, X-PEN, or CMS-P1-PLOTTER (Marking)	ZB 20,3 AXL UNPRINTED	0829579	25
Zack marker strip, flat, in 10 mm pitch, unprinted, 10-section, for individual labeling with M-PEN 0,8, X-PEN, or CMS-P1-PLOTTER (Marking)	ZBF 10/5,8 AXL UNPRINTED	0829580	50
Insert label, Roll, white, unlabeled, can be labeled with: THERMOMARK ROLLMASTER 300/600, THERMOMARK X1.2, THERMOMARK ROLL X1, THERMOMARK ROLL 2.0, THERMOMARK ROLL, mounting type: snapped into marker carrier, lettering field size: 35 x 28 mm (Marking)	EMT (35X28)R	0801602	1
Documentation	Type	Order No.	Pcs./Pkt.
User manual, English, Axioline F: System and installation	UM EN AXL F SYS INST	-	-
User manual, English, Axioline F: Diagnostic registers, and error messages	UM EN AXL F SYS DIAG	-	-

4 Technical data

Dimensions (nominal sizes in mm)

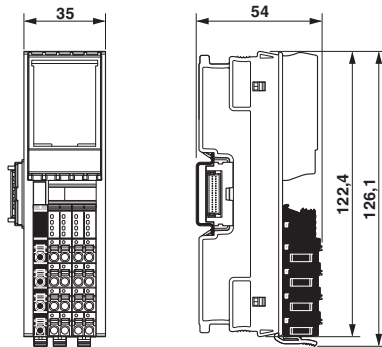

Width	35 mm
Height	126.1 mm
Depth	54 mm
Note on dimensions	The depth is valid when a TH 35-7,5 DIN rail is used (according to EN 60715).

General data

Color	traffic grey A RAL 7042
Weight	134 g (with connectors and bus base module)
Ambient temperature (operation)	-25 °C ... 60 °C
Ambient temperature (storage/transport)	-40 °C ... 85 °C
Permissible humidity (operation)	5 % ... 95 % (non-condensing)
Permissible humidity (storage/transport)	5 % ... 95 % (non-condensing)
Air pressure (operation)	70 kPa ... 106 kPa (up to 3000 m above sea level)
Air pressure (storage/transport)	70 kPa ... 106 kPa (up to 3000 m above sea level)
Degree of protection	IP20
Protection class	III, IEC 61140, EN 61140, VDE 0140-1
Mounting position	any (no temperature derating)

Connection data: Axioline F connector

Connection method	Push-in connection
Conductor cross section solid / stranded	0.2 mm ² ... 1.5 mm ² / 0.2 mm ² ... 1.5 mm ²
Conductor cross section [AWG]	24 ... 16
Stripping length	8 mm



Please observe the information provided on conductor cross sections in the "Axioline F: system and installation" user manual.

Interface: Axioline F local bus

Number	2
Connection method	Bus base module
Transmission speed	100 Mbps

Axioline F local bus supply (U_{Bus})

Supply voltage	5 V DC (via bus base module)
Current draw	max. 120 mA (up to HW 02) max. 60 mA (from HW 03)
Power consumption	max. 600 mW (up to HW 02) max. 300 mW (from HW 03)

Supply for digital output modules (U_O)

Supply voltage	24 V DC
Supply voltage range	19.2 V DC ... 30 V DC (including all tolerances, including ripple)
Current draw	min. 14 mA (without actuators) max. 8 A (provide external protection)
Power consumption	typ. 320 mW (without actuators) max. 240 W (Of which 560 mW with internal losses)
Surge protection of the supply voltage	electronic (35 V, 0.5 s)
Polarity reversal protection of the supply voltage	parallel diode; with external 5 A fuse (only for commissioning)
Protection	max. 8 A (polarity reversal protection up to 5 A)

**NOTE: Damage to the electronics**

Provide external protection for the module to protect it against polarity reversal. If you are using an external fuse, the power supply unit must be able to supply four times the nominal current of the fuse. This ensures that it trips in the event of an error.



When using the module for the first time, protect it with a 5 A fuse. When all modules in the system are correctly connected, the 5 A fuse can be replaced with an 8 A fuse. After that, you can load the module up to 8 A.

Loads over 8 A are not permitted.

Digital outputs

Number of outputs	16
Connection method	Push-in connection
Connection technology	1-wire
Nominal output voltage	24 V DC
Maximum output current per channel	500 mA
Maximum output current per device	8 A (provide external protection)
Nominal load, ohmic	max. 12 W (48 Ω , with nominal voltage)
Nominal load, inductive	max. 12 VA (1.2 H, 48 Ω , with nominal voltage)
Nominal load, lamp	max. 12 W (at nominal voltage)
Signal delay	max. 100 μ s (when switched on) max. 100 μ s (when switched off; with at least 50 mA load current)

Digital outputs

Switching frequency	max. 10000 per second (with at least 50 mA load current) max. 1 per second (with inductive load) max. 16 per second (with nominal lamp load)
Load min.	10 k Ω
Energy consumption	see diagram
Limitation of the voltage induced on circuit interruption	-25.8 V ... -15 V
Output voltage when switched off	max. 1 V
Output current when switched off	max. 300 μ A
Behavior with overload	Shutdown with automatic restart
Behavior with inductive overload	Output can be destroyed
Reverse voltage resistance to short pulses	limited protection up to 0.5 A for 1 s

**NOTE: Damage to the electronics**

If there is a faulty external voltage (reverse voltage) at one of the outputs, the output may be destroyed. This may cause unintentional setting of further outputs.

Overcurrent shut-down	as of 0.7 A
Output current with ground connection interrupt when switched off	< 1 mA
Process data update	< 100 μ s
Short-circuit protection, overload protection of the outputs	electronic

Input and output address area

Input address area	0 Byte
Output address area	2 Byte

Configuration and parameter data in a PROFIBUS system

Required parameter data	1 Byte
Required configuration data	6 Byte

Electrical isolation/isolation of the voltage areas

Test section	Test voltage
5 V communications power (logic), 24 V supply (I/O)	500 V AC, 50 Hz, 1 min.
5 V supply (logic)/functional earth ground	500 V AC, 50 Hz, 1 min.
24 V supply (I/O) / functional earth ground	500 V AC, 50 Hz, 1 min.

Mechanical tests

Vibration resistance in acc. with EN 60068-2-6/ IEC 60068-2-6	5g
Shock in acc. with EN 60068-2-27/IEC 60068-2-27	30g
Continuous shock according to EN 60068-2-27/ IEC 60068-2-27	10g

Conformance with EMC Directive 2014/30/EU**Noise immunity test in accordance with EN 61000-6-2**

Electrostatic discharge (ESD) EN 61000-4-2/ IEC 61000-4-2	Criterion B, 6 kV contact discharge, 8 kV air discharge
Electromagnetic fields EN 61000-4-3/IEC 61000-4-3	Criterion A, Field intensity: 10 V/m
Fast transients (burst) EN 61000-4-4/IEC 61000-4-4	Criterion B, 2 kV
Transient overvoltage (surge) EN 61000-4-5/ IEC 61000-4-5	Criterion B, DC supply lines: ± 0.5 kV/ ± 0.5 kV (symmetrical/ asymmetrical)
Conducted interference EN 61000-4-6/IEC 61000-4-6	Criterion A; Test voltage 10 V
Noise emission test according to EN 61000-6-3	Class B

Approvals

For the latest approvals, please visit phoenixcontact.net/products.

5 Maximum outputs power consumption when inductive loads are switched off



NOTE: Damage to the electronics
 Restrict freewheeling voltage to a maximum of -17 V when using an external freewheeling circuit! The external freewheeling circuit does not function in the case of higher negative voltages.

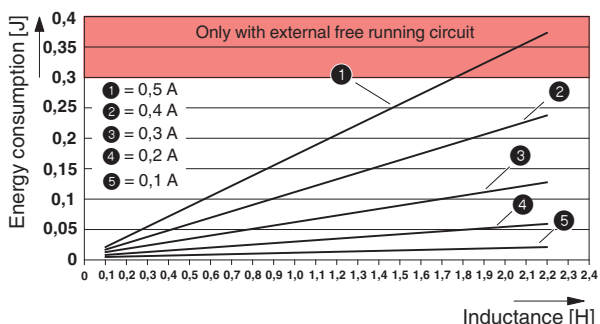

Figure 1 Maximum outputs power consumption when inductive loads are switched off

The specifications in the diagram refer to a maximum switching frequency of 1 Hz.
 The diagram shows the maximum power that can be fed back for every switch-off operation in the respective output groups (outputs 1 to 4, 5 to 8, 9 to 12, 13 to 16) when an inductive load is switched off without an external freewheel.
 The current data refers to the ohmic DC voltage component of the inductive load.

6 Internal circuit diagram

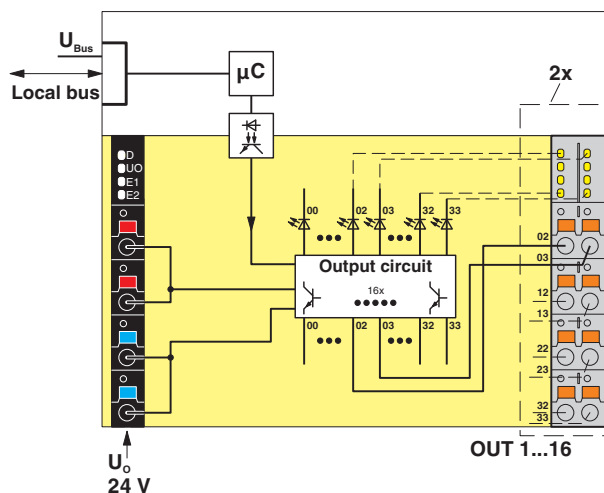

Figure 2 Internal wiring of the terminal points

Key:

- Local bus Axioline F local bus (hereinafter referred to as local bus)
- Microcontroller
- Optocoupler
- LED
- Electrically isolated areas
- Output configuration

7 Terminal point assignment

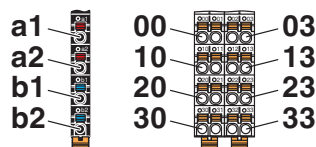

Figure 3 Terminal point assignment

Terminal point	Color	Assignment	
Supply voltage input			
a1, a2	Red	24 V DC (U _O)	Digital output module feed-in (bridged internally)
b1, b2	Blue	GND	Reference potential of the supply voltage (bridged internally)
Digital outputs			
00 ... 03	Orange	OUT01 ... OUT04	Digital outputs 1 ... 4
10 ... 13	Orange	OUT05 ... OUT08	Digital outputs 5 ... 8
20 ... 23	Orange	OUT09 ... OUT12	Digital outputs 9 ... 12
30 ... 33	Orange	OUT13 ... OUT16	Digital outputs 13 ... 16

8 Connection example

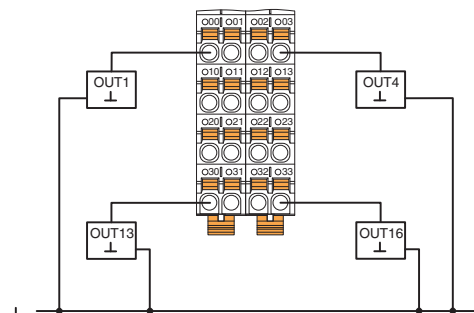

Figure 4 Connection with 1-wire technology

Make sure that the GND of the actuators and the GND for U_O have the same potential!

9 Local diagnostic and status indicators

As of hardware revision 03



Channel errors are errors that can be associated with a channel.
Periphery errors are errors that affect the entire module.

Figure 5 Local diagnostic and status indicators

Designation	Color	Meaning	State	Description
D	Red/ yellow/ green	Diagnostics of local bus communication		
		Run	Green on	The device is ready for operation, communication within the station is OK. All data is valid. An error has not occurred.
		Active	Green flashing	The device is ready for operation, communication within the station is OK. The data is not valid. No valid data provided by the controller/higher-level network. There is no error on the module.
		Device application not active	Flashing green/yellow	The device is ready for operation, communication within the station is OK. Output data cannot be outputted and/or input data cannot be read. There is a fault on the periphery side of the module..
		Ready	Yellow on	The device is ready for operation but did not detect a valid cycle after power-up.
		Connected	Yellow flashing	The device is not (yet) part of the active configuration.
		Reset	Red on	The device is ready for operation but has lost the connection to the bus head.
		Not connected	Flashing red	The device is ready for operation but there is no connection to the previously existing device.
		Power down	Off	Device is in (power) reset.
U _O	Green	U _{Output}	On	Supply for digital output modules present.
			Off	Supply for digital output modules is not present.
E1	Red	Peripheral fault	On	I/O error present.
			Off	No I/O error.
E2	Red	Channel error	On	Channel error present.
			Off	Channel error not present.
00 ... 03, 10 ... 13, 20 ... 23, 30 ... 33	Red/ yellow	Diagnostics / Status of the outputs	Red on	Short-circuit/overload of the output.
			Yellow on	Output is set.
			Off	No error, output is not set.

Deviating behavior up to hardware revision 02

Designation	Color	Meaning	State	Description
E1	Red	Peripheral fault	On	Breakdown or overload/short-circuit of an output.
			Off	No I/O error.

The LED E2 is not present.

10 Process data

I/O data is mapped in the Motorola format.

OUT process data

Byte	0							
Bit	7	6	5	4	3	2	1	0
Signal	OUT 08	OUT 07	OUT 06	OUT 05	OUT 04	OUT 03	OUT 02	OUT 01
Terminal point	13	12	11	10	03	02	01	00

Byte	1							
Bit	7	6	5	4	3	2	1	0
Signal	OUT 16	OUT 15	OUT 14	OUT 13	OUT 12	OUT 11	OUT 10	OUT 09
Terminal point	33	32	31	30	23	22	21	20

11 Parameter, diagnostics and information (PDI)

Parameter and diagnostic data as well as other information is transmitted as objects via the PDI channel of the Axioline F station.

The standard and application objects stored in the module are described in the following section.

The following applies to all tables below:

Please refer to the UM EN AXL F SYS INST for an explanation of the data types.

Abbreviation	Meaning
A	Number of elements
L	Length of the elements in bytes
R	Read
W	Write



Each visible string is terminated with a null terminator (00_{hex}). The length of a visible-string-type element is therefore at least one byte larger than the number of user data items.

If the number of user data items plus null terminator is smaller than the specified length of the element, the visible string will be populated with a null character (00_{hex}).



For detailed information on PDI objects, please refer to the UM EN AXL F SYS INST user manual.

12 Standard objects

12.1 Objects for identification (device rating plate)

As of hardware revision 03

Index (hex)	Object name	Data type	A	L	Rights	Meaning	Contents
Manufacturer							
0001	VendorName	Visible String	1	32	R	Vendor name	Phoenix Contact
0002	VendorID	Visible String	1	7	R	Vendor ID	00A045
0003	VendorText	Visible String	1	58	R	Vendor text	Components and systems for industrial automation
0012	VendorURL	Visible String	1	58	R	Vendor URL	www.phoenixcontact.com
Module - general							
0004	DeviceFamily	Visible String	1	16	R	Device family	I/O digital OUT
0006	ProductFamily	Visible String	1	32	R	Product family	AXL F
000E	CommProfile	Visible String	1	4	R	Communication profile	633
000F	DeviceProfile	Visible String	1	5	R	Device profile	0010
0011	ProfileVersion	Record of Visible Strings	2	11; 21	R	Profile version	2011-12-07; Basic - Profile V2.0
0017	Language	Record of Visible Strings	2	6; 8	R	Language	en-us; English
003A	VersionCount	Array of UINT16	4	4 * 2	R	Version counter	e.g., 0007 0001 0001 0001 _{hex}
Module - special							
0005	Capabilities	Visible String	1	8	R	Capabilities	Nothing
0007	ProductName	Visible String	1	32	R	Product name	AXL F DO16/1 1H
0008	SerialNo	Visible String	1	22	R	Serial number	e. g., 1234512345
0009	ProductText	Visible String	1	58	R	Product text	16 digital outputs
000A	OrderNumber	Visible String	1	32	R	Order No.	2688349
000B	HardwareVersion	Record of Visible Strings	2	11; 11	R	Hardware version	e. g., 2011-02-04; 00
000C	FirmwareVersion	Record of Visible Strings	2	11; 11	R	Firmware version	e.g., 2017-12-31; 1.00
000D	PChVersion	Record of Visible Strings	2	11; 6	R	PDI version	e. g., 2010-06-21; V1.00
0037	DeviceType	Octet string	1	8	R	Device type	00 40 00 02 00 00 00 D7 _{hex}
Use of the device							
0014	Location	Visible String	1	59	R/W	Location	Can be completed by the user.
0015	EquipmentIdent	Visible String	1	59	R/W	Equipment identifier	Can be completed by the user.
0016	ApplDeviceAddr	UINT16	1	2	R/W	Application device address	Can be completed by the user.

Deviating behavior up to hardware revision 02

Index (hex)	Object name	Data type	A	L	Rights	Meaning	Contents
Manufacturer							
0001	VendorName	Visible String	1	16	R	Vendor name	Phoenix Contact
0003	VendorText	Visible String	1	49	R	Vendor text	Components and systems for industrial automation
0012	VendorURL	Visible String	1	23	R	Vendor URL	www.phoenixcontact.com
Module - general							
0006	ProductFamily	Visible String	1	6	R	Product family	AXL F
0011	ProfileVersion	Record of Visible Strings	2	11; 20	R	Profile version	2011-12-07; Basis - Profil V2.0
003A	VersionCount	UINT16	4	4 * 2	R	Version counter	e.g., 0007 0001 0000 0000 _{hex}
Module - special							
0007	ProductName	Visible String	1	16	R	Product name	AXL F DO16/1 1H
0008	SerialNo	Visible String	1	11	R	Serial number	e. g., 1234512345
0009	ProductText	Visible String	1	19	R	Product text	16 digital outputs
000A	OrderNumber	Visible String	1	8	R	Order No.	2688349
000B	HardwareVersion	Record of Visible Strings	2	11; 3	R	Hardware version	e. g., 2011-02-04; 00
000C	FirmwareVersion	Record of Visible Strings	2	11; 3	R	Firmware version	0000-00-00; --

12.2 Miscellaneous standard objects

Index (hex)	Object name	Data type	A	L	Rights	Meaning/contents	
Diagnostics objects							
0018	DiagState	Record	6	58	R	Diagnostic state	*
Objects for process data management							
0026	PDOOUT	Octet string	1	2	R	Output process data	*
003B	PDIN_Descr	Array of Records	3	8; 2; 2	R	Description of the IN process data	
003C	PDOOUT_Descr	Array of Records	3	8; 2; 2	R	Description of the output process data	

The objects marked in the last column with an * are described in more detail in the next sections.

The description of the other objects is to be found in the user manual UM EN AXL F SYS INST.

The objects 003B_{hex} and 003C_{hex} are only applicable to tools.

12.3 Diagnostics objects

Diagnostics state (0018_{hex}: DiagState)

This object is used for a structured message of an error.

As of hardware revision 03

0018 _{hex} : Diagnostics state (read)					
Subindex	Data type	Length in bytes	Meaning	Contents	
0	Record	58	Diagnostic state	Complete diagnostics information	
1	UINT16	2	Error number	0 ... 65535 _{dec}	
2	UINT8	1	Priority	00 _{hex}	No error
				01 _{hex}	Error
				02 _{hex}	Warning
				81 _{hex}	Error removed
				82 _{hex}	Warning eliminated
3	UINT8	1	Channel/group/module	00 _{hex}	No error
				01 _{hex}	Channel 1 (OUT1)
			
				10 _{hex}	Channel 16 (OUT16)
				FF _{hex}	entire device
4	UINT16	2	Error code	See table below	
5	UINT8	1	More follows	00 _{hex}	
6	Visible String	51	Text	See table below	



The message with priority 81_{hex} or 82_{hex} is a one-off, internal message to the bus coupler. The bus coupler transfers this error message to the error mechanisms of the higher-level system.



After all errors have been eliminated, it is automatically reset.

Error and status of the local diagnostics and status indicators

Subindex	2	3	4	6	LED				
	Priority	Channel/group/module	Error code	Text	D	U _O	E1	E2	xx
	hex	hex	hex						
No error	00	00	0000	Status OK	●	●	○	○	○
Short-circuit/overload of an output	02	##	2344	Overload / short circuit DO##, terminal point \$\$	●	●	○	●	●
Actuator supply not present	01	FF	3422	Missing I/O supply UO, terminal point a1/a2, b1/b2	✱	○	●	○	○

##	Channel number	xx LED	Diagnostics of the output
\$\$	Terminal point number	xx	00 ... 03, 10 ... 13, 20 ... 23, 30 ... 33
○	Off	●	Green on
●	On	●	Red on
		✱	Flashing green/yellow



"Actuator supply not present" is then signaled using object 0018_{hex} and LED E1 if you have configured a setting stipulating that the error should be sent to the controller (see object FF8F_{hex}).

Deviating behavior up to hardware revision 02

0018 _{hex} : Diagnostics state (read)				
Subindex	Data type	Length in bytes	Meaning	Contents
0	Record	8	Diagnostic state	Complete diagnostics information
1	UINT16	2	Error number	0 ... 65535 _{dec}
2	UINT8	1	Priority	00 _{hex} No error
				01 _{hex} Error
				02 _{hex} Warning
				81 _{hex} Error removed
				82 _{hex} Warning eliminated
3	UINT8	1	Channel/group/module	00 _{hex} No error
				FF _{hex} entire device
4	UINT16	2	Error code	See table below
5	UINT8	1	More follows	00 _{hex}
6	Visible String	1	Text	00 _{hex}

Error and status of the local diagnostics and status indicators

Subindex	2	3	4	LED			
	Priority	Channel/group/module	Error code	D	U _O	E1	xx
Error	hex	hex	hex				
No error	00	00	0000	○	●	○	○
Short-circuit/overload of an output	02	00	2344	○	●	●	●
Actuator supply not present	01	FF	3422	○ or ✨	○	○	○

xx LED Diagnostics of the output

xx 00 ... 03, 10 ... 13, 20 ... 23, 30 ... 33

○ Off

● On

○ Green on

● Red on

✨ Flashing green/yellow

The behavior of LED D during an "Actuator supply not present" error depends on whether you have switched error reporting via the FF8F_{hex} object on or off.

Parameterization in FF8F _{hex}	D LED
Do not report error to the controller	green
Report error to the controller	flashing green/yellow

12.4 Objects for process data management

OUT process data (0026_{hex}: PDOUT)

You can read the OUT process data of the module with this object.

The structure corresponds to the representation in the "Process data" section.

0026 _{hex} : OUT process data (read)			
Subindex	Data type	Length in bytes	Meaning
0	Octet string	2	Output process data

13 Application objects

In the case of valid parameters, the parameterization is stored in the module permanently.

Index (hex)	Object name	Data type	A	L	Rights	Meaning/contents
FF8D	PD Output Substitute Configuration	UINT8	1	1	R/W	Substitute value behavior
FF8F	DiagOut	UINT8	1	1	R/W	Message "Actuator supply not present"

13.1 Substitute value behavior (FF8D_{hex}: PD Output Substitute Configuration)

With this object, you parameterize the behavior of the module so that an application reset can be detected if necessary.

FF8D _{hex} : Substitute value behavior (read, write)				
Subindex	Data type	Length in bytes	Contents	
0	Var	1	00 _{hex} (Default)	Set outputs to 0
			01 _{hex}	Hold last value

13.2 Message "Actuator supply not present" (FF8F_{hex}: DiagOut)

With this object, you parameterize whether the "Actuator supply missing" error is reported to the controller or not.

FF8F _{hex} : Message "Actuator supply not present" (Read, write)				
Subindex	Data type	Length in bytes	Contents	
0	Var	1	00 _{hex} (Default)	Do not report error to the controller
			01 _{hex}	Report error to the controller

As of hardware revision 03

If you parameterize the module so that the error is not reported to the controller, the corresponding indicator in LED E1 (red on) is suppressed. The behavior of the LED D is not affected.

Deviating behavior up to hardware revision 02

If you parameterize the module so that the error is not reported to the controller, the corresponding indicator in LED D (flashing green/yellow) is suppressed and the LED lights up green.

14 Device descriptions

The device is described in the device description files.

The device descriptions for controllers from Phoenix Contact are included in PC Worx and the corresponding service packs.

The device description files for other systems are available for download at phoenixcontact.net/products in the download area of the bus coupler used.



SCATTERGOOD & JOHNSON LTD

ELECTRICAL ENGINEERING & FLUID CONTROL DISTRIBUTORS

Est.1899

At Scattergood & Johnson Ltd, we pride ourselves on being a technical distributor to specialist industries.

Working with a range of quality product suppliers across a number of specialist markets, we are not your average 'box shifter' - we are your technical and supply chain partner.

We fully support every product we sell - for free! Our internal team and external sales engineers can answer any product or application question, no matter the complexity.

Backing up this technical ability is a range of 50,000+ products available from stock for nationwide next day delivery (same day if required!), or you can collect what you need from any of our trade counters around the UK.

Select your specialist interest below to learn more about how we can help.



Online, In Branch and On the Road - Scattergood & Johnson Ltd, there when you need us.

www.scatts.co.uk