

AXL F BK EIP

Axioline F bus coupler for EtherNet/IP™

Data sheet
106118_en_04

© PHOENIX CONTACT 2017-08-16



1 Description

The bus coupler is intended for use within an EtherNet/IP™ network and represents the link to the Axioline F I/O system. Up to 63 Axioline F devices can be connected to the bus coupler.

A corresponding EDS file is available for integrating the Axioline F station into the programming system.

This file can be downloaded via the product at phoenixcontact.net/products.

Features

- 2 Ethernet ports (with integrated switch)
- Transmission speed of 10 Mbps and 100 Mbps
- Rotary coding switches for setting the IP address assignment and other functions
- Supported protocols: SNMP, HTTP, TFTP, FTP, BootP, DHCP
- Firmware can be updated
- Typical cycle time of the Axioline F local bus is around 10 µs



This data sheet is only valid in association with the UM EN AXL F SYS INST user manual.



Make sure you always use the latest documentation. It can be downloaded from the product at phoenixcontact.net/products.

2	Table of contents	
1	Description	1
2	Table of contents	2
3	Ordering data	3
4	Technical data	4
5	Internal circuit diagram	7
6	Connecting EtherNet/IP™ and the supply	8
	6.1 Connecting EtherNet/IP™	8
	6.2 Connecting the supply voltage - terminal point assignment.....	8
7	Connection example.....	8
8	Configuration via rotary encoding switch	9
	8.1 Remote access	9
	8.2 Manual address assignment.....	9
	8.3 DHCP name assignment	10
	8.4 Static address.....	10
	8.5 Resetting IP parameters	10
	8.6 Plug and Play mode	11
	8.7 Resetting to the default settings.....	11
	8.8 Reserved/invalid switch position.....	11
9	Local diagnostic and status indicators	12
10	EtherNet/IP™ object classes, messages, and services.....	14
	10.1 CIP class and instance services	14
	10.2 CIP object classes	15
11	Reset button	16
	11.1 Restarting the bus coupler	16
	11.2 Restoring the default settings.....	16
12	Service interface.....	17
13	Startup behavior of the bus coupler	18
	13.1 Plug and Play mode	18
	13.2 Startup parameterization	18
14	Configuration methods	18
15	Mapping process data to the Assembly object	19
16	Simple Network Management Protocol - SNMP	20
17	WBM - Web-based management	20
18	Firmware update.....	20
19	Connection types.....	20
20	Device description (EDS)	20

3 Ordering data

Description	Type	Order No.	Pcs./Pkt.
Axioline F, Bus coupler, Ethernet / IP, RJ45 socket, transmission speed in the local bus 100 Mbps, degree of protection IP20, including bus base module and Axioline F connector	AXL F BK EIP	2688394	1
Accessories			
Axioline F bus base module for housing type BK (Replacement item)	AXL BS BK	2701422	5
Axioline F short power connector (for e.g., AXL F BK ...) (Replacement item)	AXL CN S/UL	2701421	5
RJ45 connector, shielded, with bend protection sleeve, 2 pieces, gray for straight cables, for assembly on site. For connections that are not crossed, it is recommended that you use the connector set with gray bend protection sleeve. (Connector/Adapter)	FL PLUG RJ45 GR/2	2744856	1
RJ45 connector, shielded, with bend protection sleeve, 2 pieces, green for crossed cables, for assembly on site. For connections that are crossed, it is recommended that the connector set with green bend protection sleeves is used. (Connector/Adapter)	FL PLUG RJ45 GN/2	2744571	1
CAT5-SF/UTP cable (J-02YS(ST)C HP 2 x 2 x 24 AWG), heavy-duty installation cable, 2 x 2 x 0.22 mm ² , solid conductor, shielded, outer sheath: 7.8 mm diameter, inner sheath: 5.75 mm ± 0.15 mm diameter (Cable/conductor)	FL CAT5 HEAVY	2744814	1
CAT5-SF/UTP cable (J-LI02YS(ST)C H 2 x 2 x 26 AWG), light-duty, flexible installation cable 2 x 2 x 0.14 mm ² , stranded, shielded, outer sheath: 5.75 mm ± 0.15 mm diameter (Cable/conductor)	FL CAT5 FLEX	2744830	1
Crimping pliers, for assembling the RJ45 plugs FL PLUG RJ45..., for assembly on site (Tools)	FL CRIMPTOOL	2744869	1
Zack marker strip for Axioline F (device labeling), in 2 x 20.3 mm pitch, unprinted, 25-section, for individual labeling with B-STIFT 0.8, X-PEN, or CMS-P1-PLOTTER (Marking)	ZB 20,3 AXL UNPRINTED	0829579	25
Zack marker strip, flat, in 10 mm pitch, unprinted, 10-section, for individual labeling with M-PEN 0,8, X-PEN, or CMS-P1-PLOTTER (Marking)	ZBF 10/5,8 AXL UNPRINTED	0829580	50
Insert label, Roll, white, unlabeled, can be labeled with: THERMOMARK ROLL, THERMOMARK ROLL X1, THERMOMARK ROLLMASTER 300/600, THERMOMARK X1.2, THERMOMARK S1.1, Mounting type: snapped into marker carrier, Lettering field: 35 x 18.7 mm (Marking)	EMT (35X18,7)R	0801831	1
Connecting cable, for connecting the controller to a PC for PC Worx and LOGIC+, USB A to micro USB B, 2 m in length. (Cable/conductor)	CAB-USB A/MICRO USB B/ 2,0M	2701626	1

Documentation	Type	Order No.	Pcs./Pkt.
User manual, English, Axioline F bus coupler for EtherNet/IP™: object classes, messages, and services	UM EN AXL F BK EIP (EF) - OBJECTS	-	-
User manual, English, Axioline F: System and installation	UM EN AXL F SYS INST	-	-
User manual, English, Axioline F: Diagnostic registers, and error messages	UM EN AXL F SYS DIAG	-	-
Quick start guide, English, Handling an Axioline F station under Startup+	UM QS EN STARTUP+	-	-
Application note, English, Updating the firmware of an Axioline F bus coupler	AH EN TFTP FIRMWARE UPDATE AXL F BK	-	-

4 Technical data

Dimensions (nominal sizes in mm)

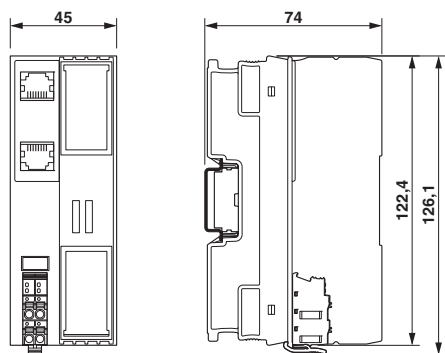

Width	45 mm
Height	126.1 mm
Depth	74 mm
Note on dimensions	The depth is valid when a TH 35-7.5 DIN rail is used (according to EN 60715).

General data

Color	traffic grey A RAL 7042
Weight	177 g (with connector and bus base module)
Ambient temperature (operation)	-25 °C ... 60 °C (Mounting position: wall mounting on horizontal DIN rail) -25 °C ... 55 °C (Mounting position: any)
Ambient temperature (storage/transport)	-40 °C ... 85 °C
Permissible humidity (operation)	5 % ... 95 % (non-condensing)
Permissible humidity (storage/transport)	5 % ... 95 % (non-condensing)
Air pressure (operation)	70 kPa ... 106 kPa (up to 3000 m above sea level)
Air pressure (storage/transport)	70 kPa ... 106 kPa (up to 3000 m above sea level)
Degree of protection	IP20
Protection class	III, IEC 61140, EN 61140, VDE 0140-1
Mounting position	Any (observe temperature derating)

Connection data

Designation	Axioline F connector
Connection method	Push-in connection
Conductor cross section solid / stranded	0.2 mm ² ... 1.5 mm ² / 0.2 mm ² ... 1.5 mm ²
Conductor cross section [AWG]	24 ... 16
Stripping length	8 mm



Please observe the information provided on conductor cross sections in the "Axioline F: system and installation" user manual.

Interface EtherNet/IP™

Number	2
Connection method	RJ45 socket
Note on connection method	Auto negotiation and autocrossing
Transmission speed	10/100 Mbps (Half or full duplex mode (automatic detection, can be adjusted manually))
Transmission physics	Ethernet in RJ45 twisted pair
Transmission length	max. 100 m

Interface Axioline F local bus

Number	1
Connection method	Bus base module
Transmission speed	100 Mbps

Interface Service

Number	1
Connection method	Micro USB type B

System limits

Number of supported devices	max. 63 (per station)
-----------------------------	-----------------------

**NOTE: Electronics may be damaged when overloaded**

Observe the logic current consumption of each device when configuring an Axioline F station. It is specified in every module-specific data sheet. The current consumption can differ depending on the individual module. The permissible number of devices that can be connected therefore depends on the specific station structure.

Protocols supported

Protocols supported	EtherNet/IP™, SNMP, HTTP, BootP, DHCP, FTP, TFTP
---------------------	--

Supply of the logic voltage U_L

Supply voltage	24 V DC
Supply voltage range	19.2 V DC ... 30 V DC (including all tolerances, including ripple)
Current draw	typ. 105 mA (without I/Os and $U_L = 24$ V) max. 583 mA (with 2 A at U_{Bus} for the I/Os and $U_L = 24$ V)
Power consumption	typ. 2.5 W (without I/Os) max. 14 W (with 2 A load at U_{Bus} for the I/Os)
Surge protection of the supply voltage	Electronic
Polarity reversal protection of the supply voltage	Electronic

**NOTE: Electronics may be damaged when overloaded**

Provide external fuses for the 24 V U_L area. The power supply unit must be able to supply four times the nominal current of the external fuse to ensure that it blows in the event of an error.

Communications power U_{Bus}

Supply voltage	5 V DC (via bus base module)
Power supply unit	2 A

Error messages to the higher level control or computer system

None

Mechanical tests

Vibration resistance in acc. with EN 60068-2-6/ IEC 60068-2-6	5g
Shock in acc. with EN 60068-2-27/IEC 60068-2-27	30g
Continuous shock according to EN 60068-2-27/ IEC 60068-2-27	10g

Conformance with EMC Directive 2014/30/EU

Noise immunity test in accordance with EN 61000-6-2

Electrostatic discharge (ESD) EN 61000-4-2/ IEC 61000-4-2	Criterion B, 6 kV contact discharge, 8 kV air discharge
Electromagnetic fields EN 61000-4-3/IEC 61000-4-3	Criterion A, Field intensity: 10 V/m
Fast transients (burst) EN 61000-4-4/IEC 61000-4-4	Criterion B, 2 kV
Transient overvoltage (surge) EN 61000-4-5/ IEC 61000-4-5	Criterion B, DC supply lines: ± 0.5 kV/ ± 0.5 kV (symmetrical/ asymmetrical), fieldbus cable shield: ± 1 kV
Conducted interference EN 61000-4-6/IEC 61000-4-6	Criterion A; Test voltage 10 V

Noise emission test according to EN 61000-6-3

Radio interference properties EN 55022	Class B
--	---------

Approvals

For the latest approvals, please visit phoenixcontact.net/products.

5 Internal circuit diagram

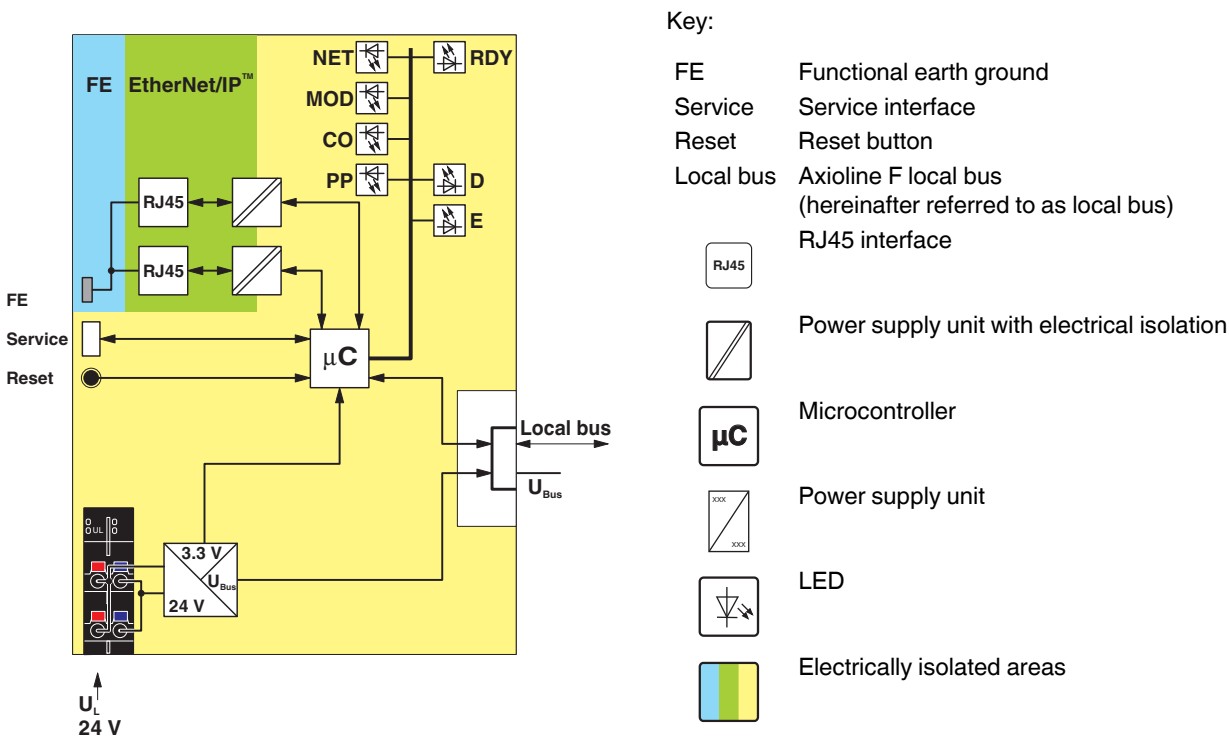

Figure 1 Internal wiring of the terminal points

6 Connecting EtherNet/IP™ and the supply

6.1 Connecting EtherNet/IP™

Connecting EtherNet/IP™ to the bus coupler via an 8-pos. RJ45 connector.

The EtherNet/IP™ connections are set to autocrossing (auto crossover).



Auto crossover is only supported in auto negotiation mode. Without auto negotiation, you can activate crossover manually in the web-based management, if necessary, using the "Manual crossover" checkbox.



Shielding
The shielding ground of the connected twisted pair cables is electrically connected with the socket. When connecting network segments, avoid ground loops, potential transfers, and voltage equalization currents via the braided shield.



Observe bending radii
The housing dimensions specified under "Dimensions" refer to the bus coupler with I/O connectors without Ethernet connection. When installing the bus coupler in a control box, observe the bending radii of the Ethernet cables and the connectors used (e.g., FL CAT5 FLEX: 30 mm for fixed installation and FL CAT5 HEAVY: 30 mm without outer sheath and 45 mm with outer sheath). If required, use angled RJ45 connectors to maintain these bending radii.

6.2 Connecting the supply voltage - terminal point assignment

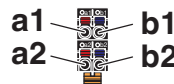

Figure 2 Terminal point assignment

Terminal point	Color	Assignment
Supply voltage input		
a1, a2	Red	24 V DC (U _L) Supply of the logic voltage (internally jumpered)
b1, b2	Blue	GND Reference potential of the supply voltage (internally jumpered)

7 Connection example

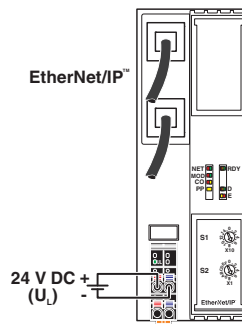

Figure 3 Connection of the cables

8 Configuration via rotary encoding switch

You can configure the address assignment and other functions using rotary encoding switches.

After modifying the switch position, restart the bus coupler, as the modification to the switch position does not take effect during operation.

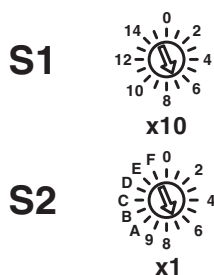

Figure 4 Rotary encoding switch

The code results from the sum of S1 x 10 plus S2 x 1. The image shows code 77 (7 x 10 + 7).

S1	S2	Code	Function
0	0	00	Remote access (default)
0 ... 5	1 ... 0	01 ... 50	Manual address assignment
5 ... 15	0 ... 9	51 ... 159	DHCP name assignment
0	A	0A	Static address
0	E	0E	Resetting IP parameters
1	A	1A	Activate Plug and Play mode
1	B	1B	Deactivate Plug and Play mode
12	C	12C	Resetting to the default settings
Other			Reserved

8.1 Remote access

Switch position 00

At this switch position, it is possible to remotely configure the device using corresponding tools (e.g., Startup+, web-based management (WBM)).

Behavior during initial startup, after resetting the IP parameters or after resetting to default settings

Default: BootP activated, DHCP deactivated

A valid IP address is not assigned (0.0.0.0) and communication is therefore not possible.

The device transmits continuous BootP requests (2 s, 4 s, 8 s, 2 s ...), until a valid IP address has been received.

Valid IP parameters are then automatically saved as configuration data on the device.

Each additional startup

BootP activated

Three BootP requests are transmitted even in the case of a valid configuration. If the device receives a BootP reply, the new IP parameters are applied.

DHCP activated

For behavior, see switch position 51 ... 159. The station name can be selected in WBM, the default station name is the MAC address with "-" used as the separator.

Static (BootP and DHCP deactivated)

The device starts with the last valid assigned IP configuration.

8.2 Manual address assignment

Switch position 01 ... 50

BootP deactivated, DHCP deactivated

The first three octets in the IP address are preset as 192.168.1.x.

The subnet mask is 255.255.255.0.

Specify the last byte with the switch position.

As such, you can select IP addresses between 192.168.1.1 and 192.168.1.50.

8.3 DHCP name assignment

Switch position 51 ... 159

This switch position is used to easily specify the DHCP host name for the device.

The host name is provided to the DHCP server via DHCP options. This is therefore able to send a DNS update to the DNS server.

The DNS name consists of one set part, which is based on the order designation, and a variable part, which is determined by the switch position.

The first part of the station name is AXL-F-BK-EIP-.

The set number is added.

This results in the following station names: AXL-F-BK-EIP-051 ... AXL-F-BK-EIP-159.

Behavior during initial startup, after resetting the IP parameters or after resetting to default settings

A valid IP address is not assigned (0.0.0.0) and communication is therefore not possible.

The device transmits continuous DHCP discover messages until a valid IP address has been received.

Each additional startup

Within the first minute, DHCP requests are transmitted with the last valid IP address.

Three cases are possible:

1. The DHCP server accepts the desired address.
⇒ The device starts with this IP address.
2. The DHCP server assigns a new IP address.
⇒ The device applies the new IP parameters.
3. The DHCP server does not respond.
⇒ The device transmits continuous DHCP Discover messages until new IP parameters have been received.

8.4 Static address

Switch position 0A

Behavior during initial startup, after resetting the IP parameters or after resetting to default settings

A valid IP address is not assigned (0.0.0.0) and communication is therefore not possible.

Assign an address initially with another switch position.

Each additional startup

After a voltage reset, the device maintains the IP address which was assigned last.



With this switch position, modifying the IP address via tools or web-based management is not possible.

8.5 Resetting IP parameters

Switch position 0E

The IP parameters stored on the device are reset.

All other settings made on the device are retained.

- BootP is activated for switch position 00.
- IP address, subnet mask: 0.0.0.0

As long as the switch position 0E remains selected, no connection to the device can be established.

IP communication is deactivated.

8.6 Plug and Play mode

Switch position 1A: activate Plug and Play mode

Switch position 1B: deactivate Plug and Play mode

Plug and Play mode enables local bus modules connected in the field to be started up using the bus coupler without a higher-level computer (engineering system).

If Plug and Play mode is enabled, the writing of process data is rejected. Read access to process data is possible.

If Plug and Play mode is disabled, the bus is only started up if the configuration of the connected bus matches the saved configuration.

See also section "Startup behavior of the bus coupler".

8.7 Resetting to the default settings

Switch position 12C

All settings are reset to default settings, including IP parameters.



The device is ready for operation after powering up, as soon as the RDY LED lights up green.

A connection to the device however cannot be established in this switch position.

As soon as the RDY LED lights up green, a new switch position can be selected on the rotary encoding switch and the device can be restarted.



Alternatively, the default setting can also be restored via the reset button (see "Reset button").

8.8 Reserved/invalid switch position

The device starts with the previous settings, e.g., with the settings that were valid before the device was restarted.

An invalid switch position is indicated by the RDY LED (red on).

9 Local diagnostic and status indicators

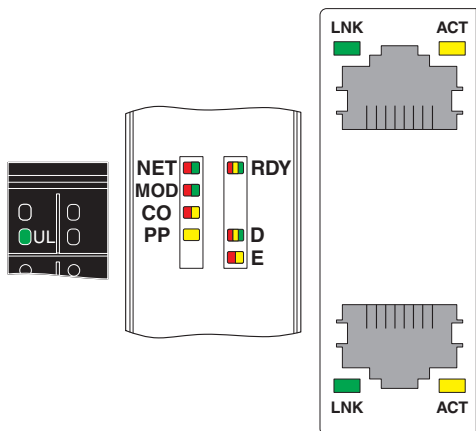

Figure 5 Local diagnostic and status indicators

Designation	Color	Meaning	State	Description
UL	Green	U _{Logic}	ON	Communications power supply present.
			OFF	Communications power supply not present.
NET	Green/ red	Network status	Green ON	At least one CIP connection is in place and the exclusive owner connection has no time-out.
			Green flashing	An IP address is configured, no CIP connection is yet in place, and the exclusive owner connection has no time-out.
			Flashing red	Connection time-out. A time-out of an exclusive owner connection has occurred.
			Red ON	An IP address conflict has been determined.
			Flashing green/red	Self test
			OFF	Device is not ready for operation.
MOD	Green/ red	Module status	Green ON	Normal operation
			Green flashing	The device is not configured.
			Red ON	A unrecoverable error has occurred.
			Flashing red	A recoverable error has occurred.
			Flashing green/red	Self test
			OFF	Device is not ready for operation.
CO	Yellow/ red	Configuration	Yellow ON	Parameterization of the I/O modules failed.
			Red ON	The active configuration of the local bus differs from the saved configuration.
			OFF	The active configuration of the local bus matches the saved configuration.
PP	Yellow	Plug and Play mode	ON	Plug and play mode is activated.
			OFF	Plug and play mode is deactivated.

Designation	Color	Meaning	State	Description
RDY	Green/ yellow/ red	Ready	Green ON	Device is ready for operation.
			Flashing green/ yellow	Communications power undervoltage or surge voltage Overtemperature
			Yellow ON	Firmware/bus coupler is booting
			Yellow flashing	Firmware update is being performed.
			Flashing yellow/red	Firmware update has failed.
			Flashing red	Faulty firmware
			Red ON	Rotary encoding switches are set to an invalid/reserved position.
			OFF	Device is not ready for operation.
D	Red/ yellow/ green	Diagnostics of local bus communication		
		Run	Green ON	The station is ready for operation, communication within the station is OK. All data is valid. There are no faults.
		Active	Green flashing	The station is ready for operation, communication within the station is OK. The data is not valid. Valid data from the controller/higher-level network not available. There is no fault in the module.
		Ready	Yellow ON	The station is ready for operation, no data exchange taking place.
			Yellow flashing	Access from Startup+ in I/O check mode
			Flashing yellow/red	Local bus error during active I/O check
			Flashing red	Local bus error on startup
				Possible causes:
				Configuration cannot be generated, information is missing from a device
				Chip version of a device is <V1.1
		The desired and actual configuration are different		
		No local bus device connected		
		The maximum number of local bus devices is exceeded.		
		Red ON	The station is ready for operation but has lost connection to at least one device.	
			Possible causes:	
			Communication error	
			Local bus device has been removed or configured device is missing.	
Reset at a local bus device				
Serious device error at a local bus device (local bus device can no longer be reached)				
Power down	OFF	Device is in (power) reset.		
E	Yellow /red	Error	Yellow ON	I/O warning at a local bus device
			Red ON	I/O error at a local bus device
			OFF	No I/O messages present.

Designation	Color	Meaning	State	Description
LNK 1/2	Green	Link port 1/2	ON	Connection via Ethernet to a module via port 1/2 established
			OFF	No connection established via port 1/2
ACT 1/2	Yellow	Activity port 1/2	Flashing	Transmission or reception of Ethernet telegrams at port 1/2
			OFF	No transmission or reception of Ethernet telegrams at port 1/2

10 EtherNet/IP™ object classes, messages, and services

The bus coupler maps the I/O device connected to the standard or user-defined CIP objects via the local bus.

The bus coupler supports the Common Industrial Protocol (CIP) according to the ODVA specification. For the objects that are supported, please refer to the “CIP object classes” table.

EtherNet/IP™ uses the Common Industrial Protocol (CIP) as the application layer. IP and TCP or UDP are used for the network and transport layers.

CIP and EtherNet/IP™ are standardized by the ODVA on a manufacturer-neutral basis.

The Common Industrial Protocol is an object-oriented protocol with two different types of communication between a controller and termination devices.

The following table describes the two communication types.

Connection type	Description
Explicit messaging	This means that a controller or an engineering system sends a request and the termination device responds. For example, explicit messaging can be used for configuration and/or diagnostics.
Implicit messaging	Implicit messaging is used for the cyclic transmission of I/O data. That means, for example, that a termination device sends an analog value which is present at a termination device input. The time for a transmission cycle can be set via the requested packet interval (RPI).

10.1 CIP class and instance services

The device supports the following class services and instance services:

Service code		Service name
dec	hex	
01	01	Get_Attribute_All
02	02	Set_Attribute_All
05	05	Reset
14	0E	Get_Attribute_Single
16	10	Set_Attribute_Single

10.2 CIP object classes

The device supports the following CIP object classes:

Class code		Object type
dec	hex	
01	01	Identity object
02	02	Router object
04	04	Assembly object
06	06	Connection manager object
55	37	File object
100	64	Configuration object
102	66	Axioline F module object
103	67	Axioline F diagnostics object
105	69	PDI object
244	F4	Port object class definition
245	F5	TCP/IP interface object
246	F6	Ethernet link object



For more detailed information, please refer to the UM EN AXL F BK EIP - OBJECTS user manual.

11 Reset button

The reset button is located beneath the top marking label on the bus coupler.

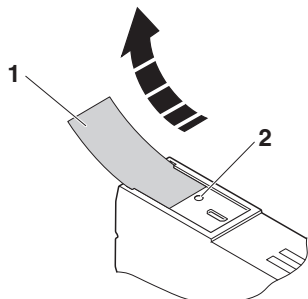

Figure 6 Reset button

- 1 Labeling field
- 2 Reset button

The reset button has two functions:

- Restarting the bus coupler
- Resetting of the default settings

11.1 Restarting the bus coupler

The bus coupler is restarted when the button is pressed during operation.

The outputs of the station are set to the parameterized substitute values.

The process image of the inputs is not re-read.

11.2 Restoring the default settings

The bus coupler is supplied with the following default settings:

Password	private
IP settings	
IP address	0.0.0.0
Subnet mask	0.0.0.0
Default gateway	0.0.0.0
BootP	activated
Firmware update	
Firmware update on next restart	deactivated
TFTP server IP address	172.16.40.201
Name of firmware update file	c2688394.fw
System identification	
Name of device	AXL F BK EIP
Description	EtherNet/IP bus terminal
Location	unknown
Contact	unknown
Plug and Play mode	activated

If you wish to restore the default settings, proceed as follows:

- Disconnect the power to the module.
- Press and hold the reset button.
- Switch on the power.

The LEDs indicate the initialization phase:

LED	State	Meaning
RDY	OFF	Starting firmware
RDY	Yellow ON	Initializing firmware
RDY	Green	Initialization complete

- When the RDY LED lights up green, release the button.

The default settings are restored.

12 Service interface

The service interface is located beneath the top marking field on the bus coupler.

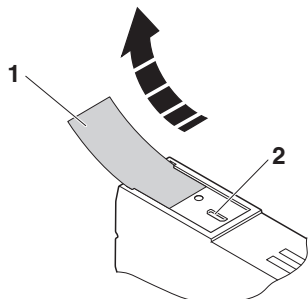

Figure 7 Service interface

- 1 Labeling field
- 2 Service interface

You can connect the bus coupler to a PC on which the Startup+ startup/diagnostic tool is running via USB using the service interface.

Startup+ offers the following functions:

- Parameterization of the station I/O modules
- I/O check
- Diagnostics



For detailed information on Startup+, please refer to the UM QS EN STARTUP+ user manual.

13 Startup behavior of the bus coupler

13.1 Plug and Play mode

Plug and play mode active

The bus coupler supports Plug and Play mode.

Plug and Play mode enables local bus modules connected in the field to be started up using the bus coupler without a higher-level computer (engineering system).

The Plug and Play mode status (active or inactive) is stored retentively on the bus coupler. The current mode is displayed via the PP LED.

In Plug and Play mode, the connected local bus modules are detected and their function checked.

If this physical configuration is ready to operate, it is started, however writing outputs is not enabled.

To enable writing outputs, Plug and Play mode must be deactivated. The deactivation is to be saved at the same time as saving the signal, active configuration, and reference configuration.

Plug and play mode inactive

When Plug and Play mode is deactivated, the reference configuration is compared to the physical configuration. If they are the same, the bus coupler is set to the RUN state on the first write access.

If the reference configuration and the physical configuration differ, the CO LED lights up red and process data exchange is no longer possible for safety reasons.

In order to operate the bus despite this, you have the following two options:

1. Restore the original configuration so that the reference configuration and the physical configuration are the same again.
2. Activate Plug and Play mode and restart the bus coupler so that the active physical configuration is accepted as the reference configuration.

13.2 Startup parameterization

There are Axioline F modules that can be parameterized (e.g., measuring ranges, substitute value behavior in the event of a bus error).

These modules can be parameterized via Startup+ or via the PDI channel (see also "Access to PDI objects").

The parameterization is stored retentively on the I/O modules, which is why this information only has to be written once on system startup.

When Plug and Play mode is deactivated, the bus coupler checks the parameterization of the I/O modules as well as the bus configuration. After the bus configuration has been changed (e.g., module replacement), the bus coupler prevents process data from being written, bit 3 is set in the Axioline F diagnostics object (class code 67_{hex}), and the CO LED lights up yellow. If necessary, adjust the parameterization and confirm this with attribute 7 ("Confirm startup parametrization") of the Configuration object (class code 64_{hex}). The bus coupler will then enable the output of process data.

14 Configuration methods

When creating, adding to or changing an Axioline F station, the I/O configuration stored in the bus coupler must be updated to match the new configuration of the station.

Configure the bus coupler using one of the following three methods:

- Electronic data sheet (EDS file)
- Auto configuration, no software required
- Sending an explicit message



For more detailed information on the configuration methods, please refer to the user manual.

15 Mapping process data to the Assembly object

The process data of the modules connected to the bus coupler are mapped to the Assembly object.

The following instances of the object are implemented:

Instance (dec)	Description
100	Output data of digital, analog, and function modules The object contains all the input data for the station.
110	Input data of digital, analog, and function modules The object contains all the output data for the station.



Approximately 1400 bytes are available in the Ethernet frame for process data.



The current mapping of process data to the process data words for the I/O modules connected to the bus coupler can be viewed via the web-based management for the bus coupler under "EtherNet/IP™, I/O Assembly table".

Example: mapping of the process data

Example of a station						
AXL F BK EIP	AXL F DI16/1 1H	AXL AO 8	AXL F DI32/1 2H	AXL F DO8/ 2-2A 2H	AXL AI 8	AXL CNT 2/ INC 2

	Input process data			Output process data		
AXL F DI16/1 1H	Word 0	Byte 0	Byte 1	Word 0	-	-
		Channel 8 ... 1	Channel 16 ... 9			
AXL AO 8	Word 1	IN1		Word 1	OUT1	
	Word 2	IN2		Word 2	OUT2	
	
	Word 8	IN8		Word 8	OUT8	
AXL F DI32/1 2H	Word 9	Byte 0	Byte 1	Word 9	-	-
		Channel 8 ... 1	Channel 16 ... 9			
	Word 10	Byte 2	Byte 3	Word 10	-	-
	Channel 24 ... 17	Channel 32 ... 25				
AXL F DO8/ 2-2A 2H	Word 11	-	-	Word 11	-	Byte 0 Channel 8 ... 1
AXL AI 8	Word 12	IN1		Word 12	-	-
	
	Word 19	IN8		Word 19	-	-
AXL CNT 2/ INC 2	Word 20	Word 0		Word 20	Word 0	
	
	Word 33	Word 13		Word 33	Word 13	



For further information on the assignment of bytes and words, please refer to the module-specific documentation (data sheet, user manual).



Unused process data words, e.g., in the case of dedicated input or output modules, are marked with "-" in the table. There is no write access to these process data words, read access always returns the value 0.

16 Simple Network Management Protocol - SNMP

The bus coupler supports SNMP v1 and v2c.

Management Information Base - MIB



The corresponding latest MIBs are available on the Internet at phoenixcontact.net/products.

For the object descriptions, please refer to the ASN1 descriptions for this product.

The password for read access is “public” and cannot be changed.

By default upon delivery, the password for write/read access is “private” and can be modified at any time.

17 WBM - Web-based management

The device has a web server, which generates the required pages for web-based management and, depending on the requirements of the user, sends them to a standard web browser.

Web-based management can be used to access static information (e.g., technical data, MAC address) or dynamic information (e.g., IP address, status information, local bus structure, and local bus diagnostics).

Calling web-based management

The device web server can be addressed using the IP address if configured accordingly. The homepage (web page) of the device is accessed by entering the URL “http://ip-address”.

Example: <http://172.16.113.38>

The default password is “private”.



If you cannot access the WBM pages, check the connection settings in your browser and deactivate the proxy, if set.

18 Firmware update

In order to update the firmware of the bus coupler, provide the bus coupler with a firmware container via a TFTP server or load it onto the bus coupler via FTP. Any FTP client or TFTP server can be used for this, e.g., the Factory Manager. If the Factory Manager is not used, initialize the firmware update via web-based management. When carrying out the firmware update, the RDY LED flashes yellow.



For detailed information on firmware update via TFTP, please refer to application note TFTP FIRMWARE UPDATE AXL F BK.

19 Connection types

The device supports the connection types Exclusive Owner, Input Only, and Listen Only.

All connection types can be configured by the scanner as a Multicast or Point to Point connection in the Target to Originator direction.

20 Device description (EDS)

In the case of EtherNet/IP™, a device description file (EDS) is required for various configuration tools.

This EDS file can be downloaded via the product at phoenixcontact.net/products.

The EDS file, which is on the bus coupler by default upon delivery, can be accessed on the bus coupler via the “File object” class code 37_{hex}.



SCATTERGOOD & JOHNSON LTD

ELECTRICAL ENGINEERING & FLUID CONTROL DISTRIBUTORS

Est.1899

At Scattergood & Johnson Ltd, we pride ourselves on being a technical distributor to specialist industries.

Working with a range of quality product suppliers across a number of specialist markets, we are not your average 'box shifter' - we are your technical and supply chain partner.

We fully support every product we sell - for free! Our internal team and external sales engineers can answer any product or application question, no matter the complexity.

Backing up this technical ability is a range of 50,000+ products available from stock for nationwide next day delivery (same day if required!), or you can collect what you need from any of our trade counters around the UK.

Select your specialist interest below to learn more about how we can help.

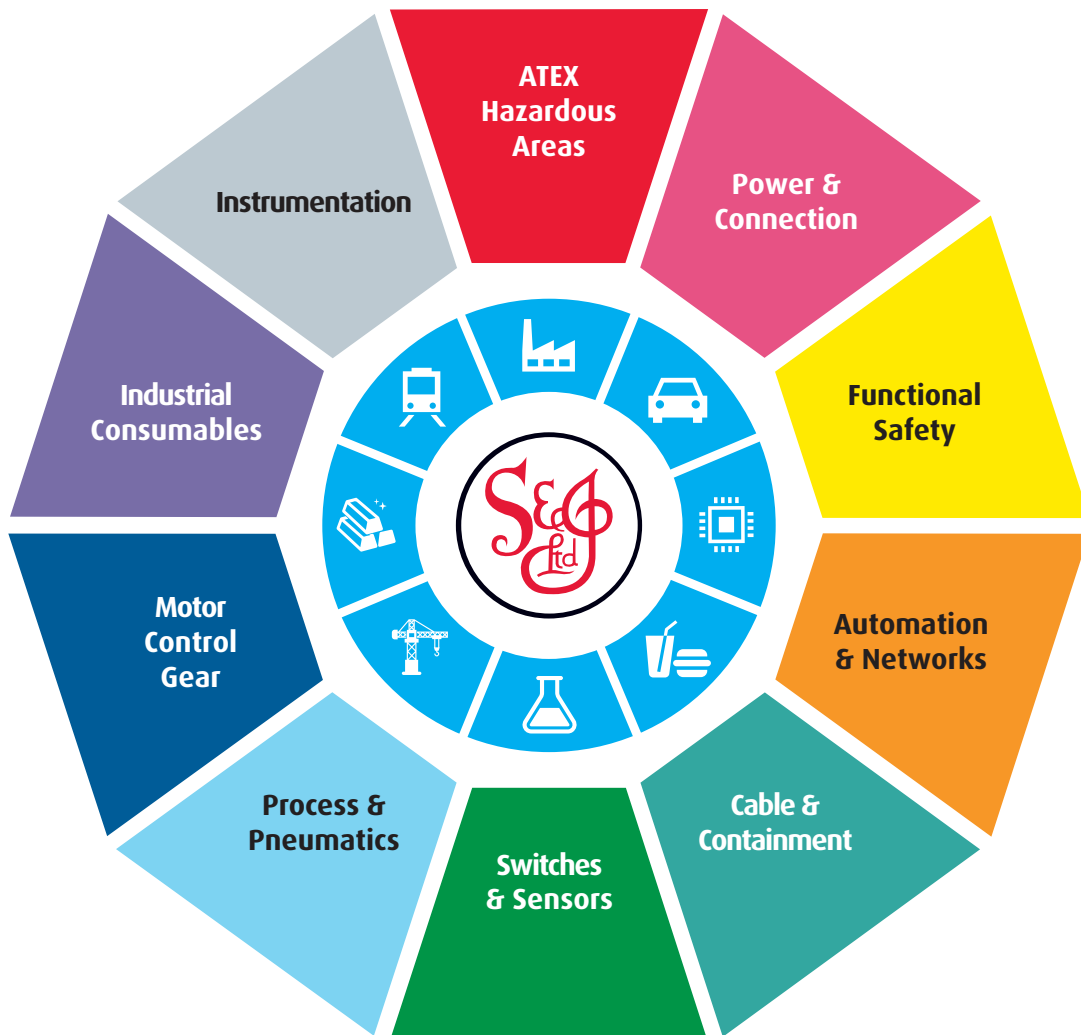

Online, In Branch and On the Road - Scattergood & Johnson Ltd, there when you need us.

www.scatts.co.uk