

AXL F BK ETH

Axioline F bus coupler for Ethernet

Data sheet
8515_en_09

© PHOENIX CONTACT 2018-10-23



1 Description

The bus coupler is intended for use within a Modbus/TCP (UDP) network and represents the link to the Axioline F I/O system.

Up to 63 Axioline F devices can be connected to the bus coupler.

Features

- 2 Ethernet ports (with integrated switch)
- Transmission speed of 10 Mbps and 100 Mbps
- Rotary coding switches for setting the IP address assignment and other functions
- Modbus/TCP (UDP) support
- BootP and DHCP
- Firmware can be updated
- Runtime in the bus coupler is negligible (almost 0 μ s) (for Modbus/UDP)
- Typical cycle time of the Axioline F local bus is around 10 μ s

Valid from firmware version 1.11.



NOTE: In the event of a connection abort, outputs retain their last state

By default upon delivery, the process data watchdog is deactivated.

Observe the specifications in "Monitoring".



Make sure you always use the latest documentation.

It can be downloaded at: phoenixcontact.net/product/2688459

2	Table of contents	
1	Description	1
2	Table of contents	2
3	Ordering data	3
4	Technical data	5
5	Internal circuit diagram	7
6	Safety note	8
7	Connecting Ethernet and supply.....	9
8	Connection example.....	9
9	Configuration via rotary encoding switch	10
10	Local diagnostic and status indicators	13
11	Reset button	15
12	Service interface.....	16
13	Startup behavior of the bus coupler	17
14	Monitoring.....	18
15	Monitoring of communications power UL (UL-Monitor).....	19
16	Substitute value behavior	19
17	Modbus protocols and registers	19
18	Access to PDI objects.....	25
19	Simple Network Management Protocol - SNMP	33
20	WBM - Web-based management	33
21	Firmware update.....	33

3 Ordering data

Description	Type	Order No.	Pcs./Pkt.
Axioline F, Bus coupler, Modbus/TCP(UDP), RJ45 socket, transmission speed in the local bus: 100 Mbps, degree of protection: IP20, including bus base module and Axioline F connector	AXL F BK ETH	2688459	1
Accessories	Type	Order No.	Pcs./Pkt.
Axioline F bus base module for housing type BK (Replacement item)	AXL BS BK	2701422	5
Axioline F short power connector (for e.g., AXL F BK ...) (Replacement item)	AXL CN S/UL	2701421	5
RJ45 connector, shielded, with bend protection sleeve, 2 pieces, gray for straight cables, for assembly on site. For connections that are not crossed, it is recommended that you use the connector set with gray bend protection sleeve. (Connector/Adapter)	FL PLUG RJ45 GR/2	2744856	1
RJ45 connector, shielded, with bend protection sleeve, 2 pieces, green for crossed cables, for assembly on site. For connections that are crossed, it is recommended that the connector set with green bend protection sleeves is used. (Connector/Adapter)	FL PLUG RJ45 GN/2	2744571	1
CAT5-SF/UTP cable (J-02YS(ST)C HP 2 x 2 x 24 AWG), heavy-duty installation cable, 2 x 2 x 0.22 mm ² , solid conductor, shielded, outer sheath: 7.8 mm diameter, inner sheath: 5.75 mm ± 0.15 mm diameter (Cable/conductor)	FL CAT5 HEAVY	2744814	1
CAT5-SF/UTP cable (J-LI02YS(ST)C H 2 x 2 x 26 AWG), light-duty, flexible installation cable 2 x 2 x 0.14 mm ² , stranded, shielded, outer sheath: 5.75 mm ± 0.15 mm diameter (Cable/conductor)	FL CAT5 FLEX	2744830	1
Crimping pliers, for assembling the RJ45 plugs FL PLUG RJ45..., for assembly on site (Tools)	FL CRIMPTOOL	2744869	1
Zack marker strip for Axioline F (device labeling), in 2 x 20.3 mm pitch, unprinted, 25-section, for individual labeling with B-STIFT 0.8, X-PEN, or CMS-P1-PLOTTER (Marking)	ZB 20,3 AXL UNPRINTED	0829579	25
Zack marker strip, flat, in 10 mm pitch, unprinted, 10-section, for individual labeling with M-PEN 0,8, X-PEN, or CMS-P1-PLOTTER (Marking)	ZBF 10/5,8 AXL UNPRINTED	0829580	50
Insert label, Roll, white, unlabeled, can be labeled with: THERMOMARK ROLLMASTER 300/600, THERMOMARK X1.2, THERMOMARK ROLL X1, THERMOMARK ROLL 2.0, THERMOMARK ROLL, mounting type: snapped into marker carrier, lettering field size: 35 x 18.7 mm (Marking)	EMT (35X18,7)R	0801831	1
Connecting cable, for connecting the controller to a PC for PC Worx and LOGIC+, USB A to micro USB B, 2 m in length. (Cable/conductor)	CAB-USB A/MICRO USB B/ 2,0M	2701626	1

Documentation	Type	Order No.	Pcs./Pkt.
Application note, English, Starting up the AXL F BK ETH ... bus coupler	AH EN AXL F BK ETH ...	-	-
User manual, English, Axioline F: System and installation	UM EN AXL F SYS INST	-	-
User manual, English, Axioline F: Diagnostic registers, and error messages	UM EN AXL F SYS DIAG	-	-
Quick start guide, English, Handling an Axioline F station under Startup+	UM QS EN STARTUP+	-	-
Application note, English, Updating the firmware of an Axioline F bus coupler	AH EN TFTP FIRMWARE UPDATE AXL F BK	-	-
Application note, English, Measures to protect network-capable devices with Ethernet connection against unauthorized access	AH EN INDUSTRIAL SECURITY	-	-

4 Technical data

Dimensions (nominal sizes in mm)

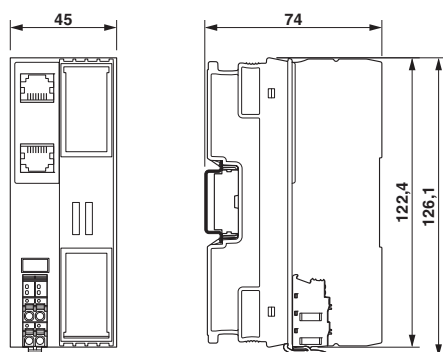

Width	45 mm
Height	126.1 mm
Depth	74 mm
Note on dimensions	The depth is valid when a TH 35-7,5 DIN rail is used (according to EN 60715).

General data

Color	traffic grey A RAL 7042
Weight	177 g (with connector and bus base module)
Ambient temperature (operation)	-25 °C ... 60 °C (Mounting position: wall mounting on horizontal DIN rail) -25 °C ... 55 °C (Mounting position: any)
Ambient temperature (storage/transport)	-40 °C ... 85 °C
Permissible humidity (operation)	5 % ... 95 % (non-condensing)
Permissible humidity (storage/transport)	5 % ... 95 % (non-condensing)
Air pressure (operation)	70 kPa ... 106 kPa (up to 3000 m above sea level)
Air pressure (storage/transport)	70 kPa ... 106 kPa (up to 3000 m above sea level)
Degree of protection	IP20
Protection class	III, IEC 61140, EN 61140, VDE 0140-1
Mounting position	any (observe temperature derating)

Connection data: Axioline F connector

Connection method	Push-in connection
Conductor cross section solid / stranded	0.2 mm ² ... 1.5 mm ² / 0.2 mm ² ... 1.5 mm ²
Conductor cross section [AWG]	24 ... 16
Stripping length	8 mm



Please observe the information provided on conductor cross sections in the "Axioline F: system and installation" user manual.

Interface: Modbus/TCP (UDP)

Number	2
Connection method	RJ45 socket
Note on the connection method	Auto negotiation and autocrossing
Transmission speed	10/100 Mbps (Half or full duplex mode (automatic detection, can be adjusted manually))
Transmission physics	Ethernet in RJ45 twisted pair
Transmission length	max. 100 m

Interface: Axioline F local bus

Number	1
Connection method	Bus base module
Transmission speed	100 Mbps

Interface: Service

Number	1
Connection method	Micro USB type B

System limits

Number of supported devices	max. 63 (per station)
Number of local bus devices that can be connected	max. 63

**NOTE: Electronics may be damaged when overloaded**

Observe the logic current consumption of each device when configuring an Axioline F station. It is specified in every module-specific data sheet. The current consumption can differ depending on the individual module. The permissible number of devices that can be connected therefore depends on the specific station structure.

Protocols supported

Protocols supported	Modbus/TCP (UDP), SNMP, HTTP, BootP, DHCP, FTP, TFTP
---------------------	--

Communications power U_L feed-in (the supply of the Axioline F local bus U_{BUS} is generated from U_L)

Supply voltage	24 V DC
Supply voltage range	19.2 V DC ... 30 V DC (including all tolerances, including ripple)
Current draw	typ. 105 mA (without I/Os and $U_L = 24$ V) max. 583 mA (with 2 A at U_{BUS} for the I/Os and $U_L = 24$ V)
Power consumption	typ. 2.5 W (without I/Os) max. 14 W (with 2 A load at U_{BUS} for the I/Os)
Surge protection of the supply voltage	electronic
Polarity reversal protection of the supply voltage	electronic

**NOTE: Electronics may be damaged when overloaded**

Provide external fuses for the 24 V U_L area. If you are using an external fuse, the power supply unit must be able to supply four times the nominal current of the fuse. This ensures that it trips in the event of an error.

Axioline F local bus supply (U_{BUS})

Supply voltage	5 V DC (via bus base module)
Power supply unit	2 A

Mechanical tests

Vibration resistance in acc. with EN 60068-2-6/ IEC 60068-2-6	5g
Shock in acc. with EN 60068-2-27/IEC 60068-2-27	30g
Continuous shock according to EN 60068-2-27/ IEC 60068-2-27	10g

Conformance with EMC Directive 2014/30/EU

Noise immunity test in accordance with EN 61000-6-2

Electrostatic discharge (ESD) EN 61000-4-2/ IEC 61000-4-2	Criterion B, 6 kV contact discharge, 8 kV air discharge
Electromagnetic fields EN 61000-4-3/IEC 61000-4-3	Criterion A, Field intensity: 10 V/m
Fast transients (burst) EN 61000-4-4/IEC 61000-4-4	Criterion B, 2 kV
Transient overvoltage (surge) EN 61000-4-5/ IEC 61000-4-5	Criterion B, DC supply lines: ± 0.5 kV/ ± 0.5 kV (symmetrical/ asymmetrical), fieldbus cable shield: ± 1 kV
Conducted interference EN 61000-4-6/IEC 61000-4-6	Criterion A; Test voltage 10 V
Noise emission test according to EN 61000-6-3	Class B

Approvals

For the latest approvals, please visit phoenixcontact.net/products.

5 Internal circuit diagram

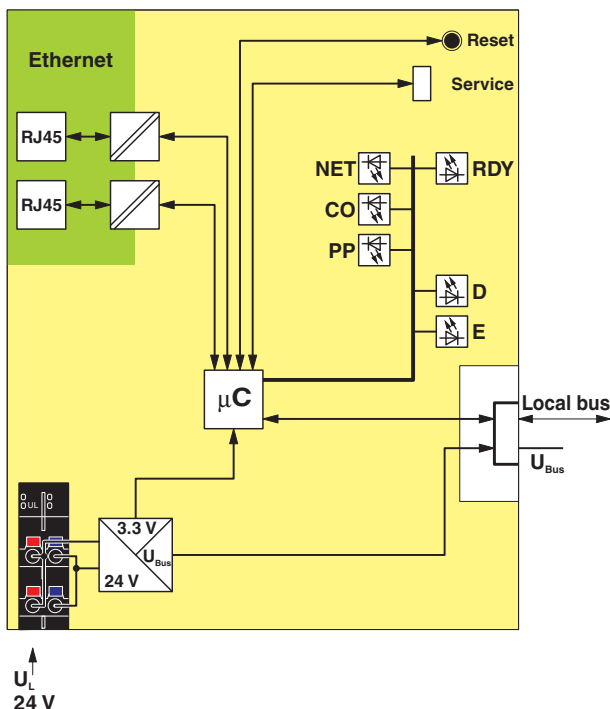

Key:

- Service Service interface
- Reset Reset button
- Local bus Axioline F local bus (hereinafter referred to as local bus)
- RJ45 RJ45 interface
- Power supply unit with electrical isolation
- Microcontroller
- Power supply unit
- LED
- Electrically isolated areas

Figure 1 Internal wiring of the terminal points

6 Safety note

**NOTE: Risk of unauthorized network access**

To prevent unauthorized network access, please read the following notes.

Connecting devices to a network via Ethernet entails the danger of unauthorized access to the network.

If possible, deactivate unused communication channels.

Assign passwords such that third-parties cannot access the bus coupler and make changes without authorization.

Due to its communication interfaces, the bus coupler should not be used in safety-critical applications without additional security appliances.

Therefore, please take additional protective measures in accordance with the IT security requirements and the standards applicable to your application (e.g. virtual networks (VPN) for remote maintenance access, firewalls, etc.) for protection against unauthorized network access.

On first request, you shall release Phoenix Contact and the companies associated with Phoenix Contact GmbH & Co. KG, Flachsmarktstrasse 8, 32825 Blomberg in accordance with §§ 15 ff. AktG (German Stock Corporation Act), hereinafter collectively referred to as "Phoenix Contact", from all third-party claims made due to improper use.

For the protection of networks for remote maintenance via VPN, Phoenix Contact offers the mGuard product series as security appliances; these are described in the latest Phoenix Contact catalog (phoenixcontact.net/products).

Additional measures for protection against unauthorized network access can be found in the AH EN INDUSTRIAL SECURITY application note. The application note can be downloaded at phoenixcontact.net/products.

7 Connecting Ethernet and supply

7.1 Connecting Ethernet

Connect Ethernet to the bus coupler via an 8-pos. RJ45 connector.

The Ethernet connections are set to autocrossing (auto crossover).



Auto crossover is only supported in auto negotiation mode. Without auto negotiation, you can activate crossover manually in the web-based management, if necessary, using the "Manual crossover" checkbox.



Shielding
The shielding ground of the connected twisted pair cables is electrically connected with the socket. When connecting network segments, avoid ground loops, potential transfers, and voltage equalization currents via the braided shield.



Observe bending radii
The housing dimensions specified under "Dimensions" refer to the bus coupler with I/O connectors without Ethernet connection. When installing the bus coupler in a control box, observe the bending radii of the Ethernet cables and the connectors used (e.g., FL CAT5 FLEX: 30 mm for fixed installation and FL CAT5 HEAVY: 30 mm without outer sheath and 45 mm with outer sheath). If required, use angled RJ45 connectors to maintain these bending radii.

7.2 Connecting the supply voltage - terminal point assignment

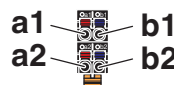

Figure 2 Terminal point assignment

Terminal point	Color	Assignment	
Supply voltage input			
a1, a2	Red	24 V DC (U _L)	Supply of the logic voltage (internally jumpered)
b1, b2	Blue	GND	Reference potential of the supply voltage (bridged internally)

8 Connection example

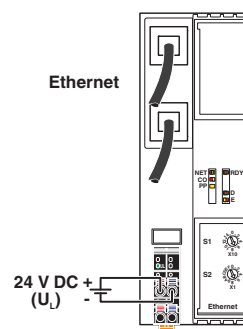

Figure 3 Connection of the cables

9 Configuration via rotary encoding switch

You can configure the address assignment and other functions using rotary encoding switches.

After modifying the switch position, restart the bus coupler, as the modification to the switch position does not take effect during operation.

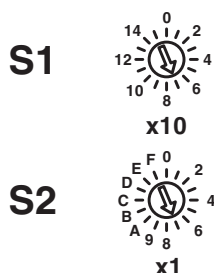

Figure 4 Rotary encoding switch

The code results from the sum of S1 x 10 plus S2 x 1. The image shows code 77 (7 x 10 + 7).

S1	S2	Code	Function
0	0	00	Remote access (default)
0 ... 5	1 ... 0	01 ... 50	Manual address assignment
5 ... 15	0 ... 9	51 ... 159	DHCP name assignment
0	A	0A	Static address
0	E	0E	Resetting IP parameters
1	A	1A	Activate Plug and Play mode
1	B	1B	Deactivate Plug and Play mode
12	C	12C	Resetting to the default settings
Other			Reserved

9.1 Remote access

Switch position 00

At this switch position, it is possible to remotely configure the device using corresponding tools (e.g., Startup+, web-based management (WBM)).

Behavior during initial startup, after resetting the IP parameters or after resetting to default settings

Default: BootP activated, DHCP deactivated

A valid IP address is not assigned (0.0.0.0) and communication is therefore not possible.

The device transmits continuous BootP requests (2 s, 4 s, 8 s, 2 s ...), until a valid IP address has been received.

Valid IP parameters are then automatically saved as configuration data on the device.

Each additional startup

BootP activated

Three BootP requests are transmitted even in the case of a valid configuration. If the device receives a BootP reply, the new IP parameters are applied. Otherwise the device starts with the last valid configuration.

DHCP activated

For behavior, see switch position 51 ... 159. The station name can be selected in WBM, the default station name is the MAC address with "-" used as the separator.

Static (BootP and DHCP deactivated)

The device starts with the last valid assigned IP configuration.

9.2 Manual address assignment

Switch position 01 ... 50

BootP deactivated, DHCP deactivated

The first three octets in the IP address are preset as 192.168.0.x.

The subnet mask is 255.255.255.0.

Specify the last byte with the switch position.

As such, you can select IP addresses between 192.168.0.1 and 192.168.0.50.

Prior to transferring the IP address, a test is performed to check for any potential IP address conflicts. If a conflict is detected, the bus coupler temporarily switches the IP address to 0.0.0.0 (no IP communication). In this case, the NET LED flashes red. Eliminate the conflict and restart the bus coupler.

9.3 DHCP name assignment

Switch position 51 ... 159

This switch position is used to easily specify the DHCP host name for the device.

The host name is provided to the DHCP server via DHCP options. This is therefore able to send a DNS update to the DNS server.

The DNS name consists of one set part, which is based on the order designation, and a variable part, which is determined by the switch position.

The first part of the station name is AXL-F-BK-ETH-.

The set number is added.

This results in the following station names: AXL-F-BK-ETH-051 ... AXL-F-BK-ETH-159.

Behavior during initial startup, after resetting the IP parameters or after resetting to default settings

A valid IP address is not assigned (0.0.0.0) and communication is therefore not possible.

The device transmits continuous DHCP discover messages until a valid IP address has been received.

Each additional startup

Within the first minute, DHCP requests are transmitted with the last valid IP address.

Three cases are possible:

1. The DHCP server accepts the desired address.
⇒ The device starts with this IP address.
2. The DHCP server assigns a new IP address.
⇒ The device applies the new IP parameters.
3. The DHCP server does not respond.
⇒ The device transmits continuous DHCP Discover messages until new IP parameters have been received.

9.4 Static address

Switch position 0A

Behavior during initial startup, after resetting the IP parameters or after resetting to default settings

A valid IP address is not assigned (0.0.0.0) and communication is therefore not possible.

Assign an address initially with another switch position.

Each additional startup

After a voltage reset, the device maintains the IP address which was assigned last.



With this switch position, modifying the IP address via tools or web-based management is not possible.

9.5 Resetting IP parameters

Switch position 0E

The IP parameters stored on the device are reset.

All other settings made on the device are retained.

- BootP is activated for switch position 00.
- IP address, subnet mask: 0.0.0.0

As long as the switch position 0E remains selected, no connection to the device can be established.

IP communication is deactivated (LED NET static yellow).

9.6 Plug and Play mode

Switch position 1A: activate Plug and Play mode

Switch position 1B: deactivate Plug and Play mode

Plug and Play mode enables local bus modules connected in the field to be started up using the bus coupler without a higher-level computer (engineering system).

If Plug and Play mode is enabled, the writing of process data is rejected. Read access to process data is possible.

If Plug and Play mode is disabled, the bus is only started up if the configuration of the connected bus matches the saved configuration.

See also section "Startup behavior of the bus coupler".

9.7 Resetting to the default settings

Switch position 12C

All settings are reset to default settings, including IP parameters.



The device is ready for operation after powering up, as soon as the RDY LED lights up green.

A connection to the device however cannot be established in this switch position.

As soon as the RDY LED lights up green, a new switch position can be selected on the rotary encoding switch and the device can be restarted.



Alternatively, the default setting can also be restored via the reset button (see "Reset button").

9.8 Reserved/invalid switch position

The device starts with the previous settings, e.g., with the settings that were valid before the device was restarted.

An invalid switch position is indicated by the RDY LED (red on).

10 Local diagnostic and status indicators

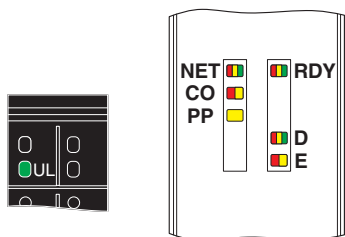

Figure 5 Local diagnostic and status indicators

Designation	Color	Meaning	State	Description
UL	Green	U _{Logic}	On	Communications power supply present.
			OFF	Communications power supply not present.
NET	Green/ yellow/ red	Network status	Green on	At least one connection has been established to the device.
			Green flashing	A connection can be established to the device.
			Yellow on	IP configuration (IP address) is invalid (0.0.0.0).
			Yellow flashing	BootP requests or DHCP requests/discover messages are being transmitted.
			Red on	Network error; the process data watchdog was activated, the substitute value behavior of the outputs is performed.
			Flashing red	An IP address conflict has occurred during static configuration via rotary coding switches (IP address assigned twice).
			OFF	Device is not ready for operation.
CO	Yellow/ red	Configuration	Yellow on	Parameterization of the I/O modules failed.
			Red on	The active configuration of the local bus differs from the saved configuration.
			OFF	The active configuration of the local bus matches the saved configuration.
PP	Yellow	Plug and Play mode	On	Plug and Play mode is activated.
			OFF	Plug and Play mode is deactivated.
RDY	Green/ yellow/ red	Ready	Green on	Device is ready for operation
			Flashing green/ yellow	Communications power undervoltage or surge voltage Overtemperature
			Yellow on	Firmware/bus coupler is booting
			Yellow flashing	Firmware update is being performed.
			Flashing yellow/ red	Firmware update has failed.
			Flashing red	Faulty firmware
			Red on	Rotary encoding switches are set to an invalid/reserved position.
			OFF	Device is not ready for operation.

Designation	Color	Meaning	State	Description
D	Red/ yellow/ green	Diagnostics of local bus communication		
		Run	Green on	The station is ready for operation, communication within the station is OK. All data is valid. There are no faults.
		Active	Green flashing	The station is ready for operation, communication within the station is OK. The data is not valid. Valid data from the controller/higher-level network not available. There is no fault in the module.
		Ready	Yellow on	The station is ready for operation, no data exchange taking place.
			Yellow flashing	Access from Startup+ in I/O check mode
			Flashing yellow/red	Local bus error during active I/O check (with connected Startup+)
			Flashing red	Local bus error on startup
				Possible causes:
				Configuration cannot be generated, information is missing from a device
				Chip version of a device is <V1.1
				The desired and actual configuration are different
				No local bus device connected
		The maximum number of local bus devices is exceeded.		
	Red on	The station is ready for operation but has lost connection to at least one device.		
		Possible causes:		
		Communication error		
		Local bus device has been removed or configured device is missing.		
		Reset at a local bus device		
		Serious device error at a local bus device (local bus device can no longer be reached)		
	Power down	OFF	Device is in (power) reset.	
E	Yellow/ red	Error	Yellow on	I/O warning at a local bus device
			Red on	I/O error at a local bus device
			OFF	No I/O messages present.
LNK 1/2	Green	Link port 1/2	On	Connection via Ethernet to a module via port 1/2 established
			OFF	No connection established via port 1/2
ACT 1/2	Yellow	Activity port 1/2	Flashing	Transmission or reception of Ethernet telegrams at port 1/2
			OFF	No transmission or reception of Ethernet telegrams at port 1/2



If your station only contains input modules, write "0" to register 9000 at least once after each restart of the bus coupler in order to ensure that the process data is valid. The LED D on the bus coupler and the local bus devices then switch from flashing green to steady green.
As an alternative, write "0" to register 9000 periodically.

11 Reset button

The reset button is located beneath the top marking label on the bus coupler.

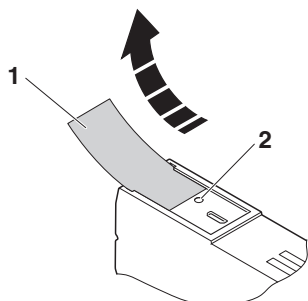

Figure 6 Reset button

- 1 Labeling field
- 2 Reset button

The reset button has two functions:

- Restarting the bus coupler
- Resetting of the default settings

11.1 Restarting the bus coupler

The bus coupler is restarted when the button is pressed during operation.

The outputs of the station are set to the parameterized substitute values.

The process image of the inputs is not re-read.

11.2 Restoring the default settings

The bus coupler is supplied with the following default settings:

Password	private
IP settings	
IP address	0.0.0.0
Subnet mask	0.0.0.0
Default gateway	0.0.0.0
BootP	activated
Firmware update	
Firmware update on next restart	deactivated
TFTP server IP address	172.16.40.201
Name of firmware update file	c2688459.fw
System identification	
Name of device	AXL F BK ETH
Description	Ethernet bus terminal
Location	unknown
Contact	unknown
Process data monitoring	
Process data watchdog time-out	0 (deactivated)
Plug and Play mode	activated

If you wish to restore the default settings, proceed as follows:

- Disconnect the power to the module.
- Press and hold the reset button.
- Switch on the power.

The LEDs indicate the initialization phase:

LED	State	Meaning
RDY	OFF	Starting firmware
RDY	Yellow on	Initializing firmware
RDY	Green	Initialization complete

- When the RDY LED lights up green, release the button. The default settings are restored.

12 Service interface

The service interface is located beneath the top marking field on the bus coupler.

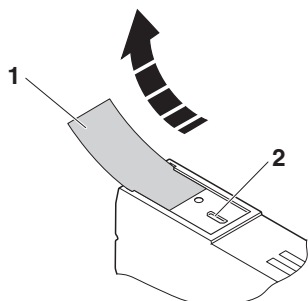

Figure 7 Service interface

- 1 Labeling field
- 2 Service interface

You can connect the bus coupler to a PC on which the Startup+ startup/diagnostic tool is running via USB using the service interface.

Startup+ offers the following functions:

- Parameterization of the station I/O modules
- I/O check
- Diagnostics



For detailed information on Startup+, please refer to the UM QS EN STARTUP+ user manual.

13 Startup behavior of the bus coupler

13.1 Plug and Play mode

Plug and Play mode active

The bus coupler supports Plug and Play mode.

Plug and Play mode enables local bus modules connected in the field to be started up using the bus coupler without a higher-level computer (engineering system).

The Plug and Play mode status (active or inactive) is stored retentively on the bus coupler. The current mode is displayed via the PP LED.

In Plug and Play mode, the connected local bus modules are detected and their function checked.

If this physical configuration is ready to operate, it is started, however writing outputs is not enabled.

To enable writing outputs, Plug and Play mode must be deactivated. The deactivation is to be saved at the same time as saving the signal, active configuration, and reference configuration.

Plug and Play mode inactive

When Plug and Play mode is deactivated, the reference configuration is compared to the physical configuration. If they are the same, the bus coupler is set to the RUN state on the first write access.

If the reference configuration and the physical configuration differ, the CO LED lights up red and process data exchange is no longer possible for safety reasons.

In order to operate the bus despite this, you have the following two options:

1. Restore the original configuration so that the reference configuration and the physical configuration are the same again.
2. Activate Plug and Play mode and restart the bus coupler so that the active physical configuration is accepted as the reference configuration.

13.2 Startup parameterization

There are Axioline F modules that can be parameterized (e.g., measuring ranges, substitute value behavior in the event of a bus error).

These modules can be parameterized via Startup+ or via the PDI channel (see also "Access to PDI objects").

The parameterization is stored retentively on the I/O modules, which is why this information only has to be written once on system startup.

When Plug and Play mode is deactivated, the bus coupler checks the parameterization of the I/O modules as well as the bus configuration. After the bus configuration has been changed (e.g., module replacement), the bus coupler prevents process data from being written, bit 3 is set in the status register (7996), and the LED CO lights up yellow.

Modify the parameterization as appropriate and acknowledge this with code 0008_{hex} in the command register (2006). The bus coupler will then enable the output of process data.

14 Monitoring

Ethernet communication is monitored by a process data watchdog.

The following actions are monitored:

- Client application
- Ethernet connection
- Process data exchange

If the timeout period expires for the activated process data watchdog, OUT process data is blocked. The parameterized substitute value behavior of I/O modules is performed. The error is indicated by the NET LED (red on).

In this state (Net Fail), OUT process data can continue to be updated by the application. Following a Net Fail reset, substitute values are then replaced by the latest process data.



NOTE: In the event of a connection abort, outputs retain their last state

The process data watchdog is deactivated by default.

Activate the process data watchdog before starting up an application.

Function of the process data watchdog

If station outputs are set, the controlling process must be able to access the station.

In the event of an error, e.g., network line interrupted or function error in the controlling process, the bus coupler can respond appropriately via the process data watchdog.

When activating the process data watchdog, it is started by the first write process and the next write process is expected within the time-out period. During error-free operation, the write process is performed during the time-out period and the watchdog is restarted (triggered).



Reading calls do not trigger the process data watchdog.

Net fail

If there is no triggering during the time-out period, an error occurred. Two responses follow:

- All outputs are set to the configured substitute value.
- The Net Fail signal is set (NET LED is red and bit 1 in status register 7996 is set).

For safety reasons, the user cannot stop the watchdog once it has been activated.

If the user terminates the controlling application, there is no watchdog triggering; when the timeout period elapses, the Net Fail signal is set and the parameterized substitute value behavior is executed. After the watchdog has performed its task, the outputs are only enabled again after acknowledgment.

Acknowledge error message

To reset the error, it must be acknowledged.

The following options are available:

- Web-based management
- Modbus register 2006



When the error is acknowledged, the watchdog is restarted. This means that it must be triggered during the time-out period, otherwise an error is detected again.

Configuring the process data watchdog

- To activate the watchdog, specify the desired time-out value in the range between 200 ms and 65000 ms.
- To deactivate the watchdog, specify the value 0.

You have the following options for changing the time-out period:

- Web-based management
- Modbus register 2000

15 Monitoring of communications power U_L (UL-Monitor)

A monitoring function monitors the supply of communications power U_L . If the value is outside the specified voltage range, this is indicated in status register 7996.

Undervoltage	
Bit 12	Set as long as the communications power is too low.
Bit 14	Still set after a brief undervoltage.

Surge voltage	
Bit 13	Set as long as the communications power is too high.
Bit 15	Still set after a brief surge voltage.

Very brief voltage disturbances are also registered with bits 14 and 15. Both bits remain set until the UL-Monitor has been acknowledged with code 0080_{hex} via command register 2006.

16 Substitute value behavior

If Ethernet communication fails or an error occurs in the local bus, all outputs of the station are set to the substitute values previously parameterized on the module.

In order to do this, Plug and Play mode must be deactivated and the process data watchdog must be activated.



For the possible substitute values of a module, please refer to the relevant module-specific data sheet.

17 Modbus protocols and registers

The bus coupler supports a Modbus/TCP server and a Modbus/UDP server.

The Modbus protocol can be used in both in a connection-related (TCP) and wireless (UDP) manner.

17.1 Modbus connections

Modbus/TCP

The bus coupler supports up to eight Modbus/TCP connections simultaneously.

The connection can access different addresses simultaneously.

Since eight connections are supported, a connection can quickly be restored. This means that the client can successfully restore an interrupted Modbus connection.

Modbus/UDP

The UDP server is wireless.



In applications with high demands on the response time, it is recommended that Modbus/UDP is used to access the process data. In this case, the runtime in the bus coupler is negligible (just a few μ s).

Modbus/TCP and Modbus/UDP



The procedures for interlocking or priority switching of the client are not implemented.

17.2 Modbus conformance classes

The bus coupler supports Modbus conformance class 0.

17.3 Modbus function codes

The following function codes are supported:

Function code	Function	Description
FC3	Read holding registers	Read words from outputs and inputs
FC4	Read input registers	Read words from inputs
FC6	Write single registers	Write word for output data
FC16	Write multiple registers	Write several output words
FC23	Read/write multiple registers	Read and write several process data for inputs and outputs

17.4 Modbus register

Modbus register table (16-bit word)	Access	Function	Access with function code
Local bus			
1400	R	Number of local bus devices/entries	FC3, FC4
1401 ... 1649	R	Device type of local bus devices (4 registers per device)	
1700	R	Number of local bus devices/entries	
1701 ... 1763	R	Number of process data registers (8xxx or 9xxx) for local bus devices (1 register per device)	
1800	R	Number of local bus devices/entries	
1801 ... 1989	R	I/O diagnostics of local bus devices (3 registers per device)	
Special register			
2000	R/W	Time-out for process data watchdog	FC3, FC4, FC6, FC16
2006	W	Command register	FC6, FC16
2075 ... 2089	R	Electronic rating plate	FC3, FC4
PDI			
6010 ... 6089	R/W	Tunnel register for PDI requests (channel 1 ... 8)	FC3, FC4, FC6, FC16, FC23
6210 ... 6289	R	Tunnel register for PDI confirmations (channel 1 ... 8)	FC3, FC4, FC23
Diagnostics			
7996	R	Status register	FC3, FC4, FC23
7997	R	Diagnostic status register	
7998	R	Diagnostic parameter register 1	
7999	R	Diagnostic parameter register 2	
Process data			
8000 ... 8999	R	Input process data	FC3, FC4, FC6, FC16, FC23
9000 ... 9999	R/W	Output process data	

R Read
W Write



In write access to the Modbus/TCP clients on the "Read only" register, the data is not transferred and is answered with exception code 02.

17.5 Figure showing process data on Modbus registers (8000 ... 8999, 9000 ... 9999)

The process data of the modules connected to the bus coupler are mapped in one register range. The registers are assigned in the same way for all function codes, they are not differentiated according to the data types implicated in the function codes (e.g. Modbus register and Modbus input register).

For address assignment, all IN process data of the connected modules is mapped according to the physical bus configuration from Modbus register 8000 (up to 8999, maximum).

All OUT process data is mapped according to the physical bus configuration from Modbus register 9000 (up to 9999, maximum).

A number of registers is assigned to each module according to the data width. Each register comprises 16 bits. A module with a data width of 8 bits is mapped on one register, a module with 32 bits is mapped on two registers.

No differentiation is made between digital and analog modules.



The current mapping of process data to the Modbus register for the I/O modules connected to the bus coupler can be viewed via the web-based management for the bus coupler under "Modbus/TCP (UDP), Modbus I/O table".

Example: figure of process data on the Modbus register

Example of a station						
AXL F BK ETH	AXL F DI16/1 1H	AXL F AO8 1F	AXL F DI32/1 2H	AXL F DO8/ 2-2A 2H	AXL F AI8 1F	AXL F CNT2 INC2 1F

	Input process data			Output process data		
AXL F DI16/1 1H	8000	Byte 0	Byte 1	9000	-	-
		Channel 8 ... 1	Channel 16 ... 9			
AXL F AO8 1F	8001	IN1		9001	OUT1	
	8002	IN2		9002	OUT2	
	
	8008	IN8		9008	...	
AXL F DI32/1 2H	8009	Byte 0	Byte 1	9009	-	-
		Channel 8 ... 1	Channel 16 ... 9			
	8010	Byte 2	Byte 3	9010	-	-
		Channel 24 ... 17	Channel 32 ... 25			
AXL F DO8/ 2-2A 2H	8011	-	-	9011	-	Byte 0 Channel 8 ... 1
AXL F AI8 1F	8012	IN1		9012	-	-
	
	8019	IN8		9019	-	-
AXL F CNT2 INC2 1F	8020	Word 0		9020	Word 0	
	
	8033	Word 13		9033	Word 13	
	...	Reserved		...	Reserved	
	8999	Reserved		9999	Reserved	



For further information on the assignment of bytes and words, please refer to the module-specific documentation (data sheet, user manual).



Unused registers, e.g., in the case of dedicated input or output modules, are marked with "-" in the table. There is no write access to these registers, read access always returns the value 0.

17.6 Register tables for the bus configuration frame (1401 ... 1649 / 1701 ... 1763)

Both register tables map the currently loaded bus configuration frame of the connected devices. When Plug and Play mode is activated, the bus configuration frame that is physically present is sent. When Plug and Play mode is deactivated, the stored reference configuration is sent.

Any differences between the stored reference configuration and the bus configuration that is physically present are indicated by diagnostic registers 7997 to 7999. The register tables can be used to monitor the bus configuration in the user application. The entire table can always be read, the "Number of entries" register indicates how many entries there actually are.

Register table for DeviceType (1401 ... 1649)

The DeviceType is a manufacturer-specific module identification. It can be used to replace and operate modules of the same type within a bus configuration. For example, a 16-channel output module with screw connection technology can be replaced by a module with spring-cage connection technology even though it does not have the same order number. On the other hand, a different functionality (e.g., 32 channels instead of 16) is indicated by a different DeviceType.

In this case the DeviceType acts as a uniquely assigned ID, but the module functionality cannot be directly derived from it (e.g., by evaluating a specific bit). Should this be necessary, use the relevant PDI objects for this (see module-specific data sheet).

Structure of the register table

Index	Contents	
1400	Number of entries	1 ... 63
1401	DeviceType	1st device
1402		
1403		
1404		
...
1646	DeviceType	63rd device
1647		
1648		
1649		

Register table for the number of process data registers for local bus devices (1701 ... 1763)

This register table indicates the number of registers in the process data register tables occupied by each device (8000...8999, 9000...9999). This information can be used to dynamically adapt the user application to changes in the bus configuration. The offset for the relevant device in the process data register table can therefore be calculated in the user application.

Structure of the register table

Index	Contents	
1700	Number of entries	1 ... 63
1701	Number of process data registers	1st device
...
1763	Number of process data registers	63rd device

17.7 Register for I/O diagnostics (1800 ... 1989)

The register table shows the error number, priority, channel/group/module, and error code information contained in diagnostic object 0018_{hex} for every device.

For every device, the first message is displayed with the highest priority.

You can view the entire table at any time.



This table should not be read cyclically. Bits 0 and 1 in diagnostic status register 7997 indicate that an error message is present. This register can be read cyclically together with the process data. If either of these bits is set, read the registers for I/O diagnostics acyclically.

Modbus register	Device	High byte	Low byte
1800	1 ... 63	Number of valid entries (number of devices)	
1801	1.	Error number	
1802		Priority	Channel/group/module
1803		Error code	
...
1987	63rd	Error number	
1988		Priority	Channel/group/module
1989		Error code	



For details of the contents of the fields for error number, priority, channel/group/module, and error code from PDI object 0018_{hex}, please refer to the module-specific documentation (data sheet, user manual).

17.8 Command register (2006)

The bus coupler behavior can be controlled via the command register. Only write access is enabled for the register.

In the event of invalid requests (codes that are not supported), an error message is returned.

Code (hex)	Meaning
0000	No action
0001	Switch on Plug and Play mode applied only following restart
0002	Switch off Plug and Play mode applied immediately
0008	Acknowledge startup parameterization applied immediately, parameterization is permanently acknowledged, i.e. successful restart does not result in another message
0010	Set Net Fail
0020	Acknowledge Net Fail
0080	Reset UL-Monitor (see "Monitoring of communications power U _L ")
0400	Activate hardware acceleration for Modbus/UDP applied only following restart
0800	Deactivate hardware acceleration for Modbus/UDP applied only following restart
8100	Deactivate web-based management
8101	Activate web-based management
8F00	Restart bus coupler
8F01	Read parameter file again (config.svc)



When commands 8F00_{hex} and 8F01_{hex} are being executed, the substitute value behavior of the outputs is active.



The hardware acceleration for Modbus/UDP shortens the processing time of Modbus/UDP requests. It is enabled by default. In the event of compatibility problems, deactivate the hardware acceleration with code 0800_{hex} in the command register and perform a restart. This setting is stored retentively.

17.9 Electronic rating plate (2075 ... 2089)

The electronic rating plate contains the basic information on the module.

Only read access is enabled to the registers.

Modbus register	Function	Maximum length of the register
2075	Name of device	125
2076	Description	125
2077	Location	125
2078	Contact	125
2079	Boot loader version	4
2080	Firmware version	6
2081	Firmware status	4
2082	Hardware version	2
2083	Firmware date	4
2084	Hardware date	4
2085	Serial number	10
2086	MAC address	9
2087	Order No.	10
2088	Order designation	15
2089	Vendor name	10

17.10 Status register (7996)

The status register indicates the status of the bus coupler. Each bit has a different meaning. Several bits can be set simultaneously. No bit is set in normal operation without errors.

Bit	Code (hex)	Meaning
0	0001	1 An error occurred in the local bus (e.g., a bit in the diagnostic register is set)
		0 No error
1	0002	1 A Net Fail occurred, active substitute values
		0 No error
2	0004	1 Active bus configuration does not match the reference configuration
		0 No error
3	0008	1 Startup parameterization is faulty
		0 No error
4	0010	1 Plug and Play mode is activated.
		0 Plug and Play mode is deactivated.
5	0020	1 Startup not completed
		0 Startup completed
6	0040	Reserved
7	0080	Reserved
8	0100	1 Overtemperature of the power supply
		0 Normal temperature
9	0200	1 Overtemperature of the logic PCB
		0 Normal temperature
10	0400	Reserved
11	0800	Reserved
12	1000	1 U _L -Monitor: communications power too low
		0 Voltage OK
13	2000	1 U _L -Monitor: communications power too high
		0 Voltage OK
14	4000	1 U _L -Monitor: communications power too low (acknowledge code 0080 _{hex} via register 2006)
		0 No error stored
15	8000	1 UL-Monitor: communications power too high (acknowledge code 0080 _{hex} via register 2006)
		0 No error stored

17.11 Diagnostic status register (7997)



For the meaning of this register, please refer to the AXL F SYS DIAG user manual.

17.12 Diagnostic parameter register (7998, 7999)



For the meaning of this register, please refer to the AXL F SYS DIAG user manual.

18 Access to PDI objects

PDI stands for parameter, diagnostics, and information. The PDI channel is used in addition to the process data channel in the Axioline F system for the demand-oriented, acyclic transmission of parameter and diagnostic data as well as other information. Each Axioline F device has this channel and can use it independently of the process data.

Objects created in the Axioline F device can be accessed via the PDI channel using services. These objects can be used, for example, to set measuring ranges, to specify the

substitute value behavior of outputs in the event of a bus error or to read diagnostic details.

The objects are addressed via an object index (e.g., 0018_{hex}: DiagState). For detailed information on the objects present on a module, please refer to the module-specific documentation.

You can access the PDI channel via Modbus/TCP as well as via Modbus/UDP. To this end, register sets are used, with which a tunnel method can be implemented. This method is explained below.

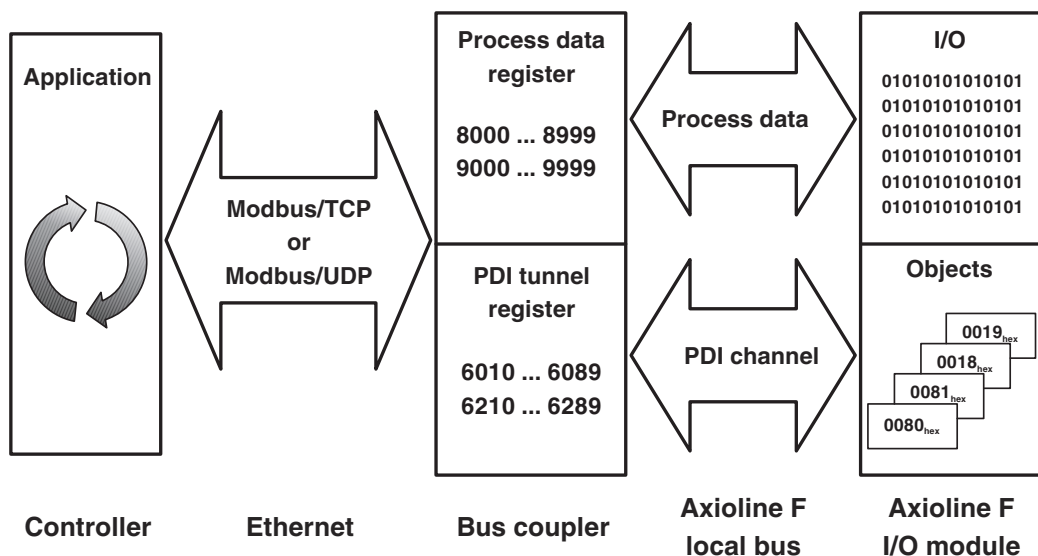

Figure 8 Access to PDI objects

18.1 Functional description

Eight Modbus PDI channels are provided, which are to be assigned to the Modbus masters in the application without causing conflict.

**NOTE: Data loss**

Use an appropriate channel assignment to ensure that one channel is only ever used by one master.

Each Modbus PDI channel features a request table and confirmation table.

The data necessary for a PDI request (PDI read or PDI write) is written to the request table by means of Modbus write access (FC16/FC23).

Subsequently, the PDI confirmation is read out of the confirmation table via Modbus read access (FC3, FC4, FC23).

You can use the PDI service with Modbus function code FC23 very easily; access to the request and the confirmation table is possible with just one access.

The confirmation table can only be accessed as read-only, whereas both read and write access are enabled for the request table. In the case of read-only access to the request table, the most recently written data is output (not the PDI confirmation).

The 6x5 data registers (e.g., 6015, 6215) have a “virtual length”. This means that data can be transmitted, as long as the maximum length of the Modbus telegram is not exceeded. The data is mapped internally onto the following registers (not directly), thereby ensuring a higher packing density of the PDI channels. Use a Modbus function code for access, which allow access to multiple registers in one request (FC3, FC16 or FC23).

As such, the register, e.g., 6215 functions as a start address. Always use 125 as the register number when read-accessing a PDI object (PDI read). In the case of write access to a PDI object (PDI write), use the corresponding length. Please see the following examples.

As such, read access to the confirmation table is granted with a specified length. The specified number of registers is always output. If the actual data length is lower (e.g., PDI object is smaller or contains a negative confirmation), all remaining registers are filled with “0000”. The actual length of the PDI object can be found in the field “Number of PDI data bytes”. If the actual length is longer, only the requested data is output.

18.2 Structure of the Modbus PDI communication channels

Modbus PDI communication channel 1						
PDI request			PDI confirmation			
Modbus register	Byte	Meaning	Modbus register	Byte	Positive response	Negative response
6010	0	Command code	6210	0	Message code	Message code
	1			1		
6011	2	Slot	6211	2	Slot	Slot
	3			3		
6012	4	Subslot	6212	4	Subslot	Subslot
	5	Reserved		5	Reserved	Reserved
6013	6	PDI object index	6213	6	PDI object index	PDI object index
	7			7		
6014	8	Subindex	6214	8	Subindex	Subindex
	9	Number of PDI data bytes		9	Number of PDI data bytes	0
6015	10	Data byte 0	6215	10	Error class	Error class
	11	Data byte 1		11	Error code	Error code
6016*	12	Data byte 2	6216*	12	Data byte 0	Additional error code
	13	Data byte 3		13	Data byte 1	
6017*	14	Data byte 4	6217*	14	Data byte 2	
	15	Data byte 5		15	Data byte 3	
...

Modbus PDI channels and corresponding Modbus registers

Modbus PDI communication channel			
1	2	...	8
PDI request			
6010 ... 6015	6020 ... 6025	...	6080 ... 6085
PDI confirmation			
6210 ... 6215	6220 ... 6225	...	6280 ... 6285

Command code

0041_{hex} Read PDI object
 0042_{hex} Write PDI object

Message code

8041_{hex} Response to "Read PDI object"
 8042_{hex} Response to "Write PDI object"

Slot

Position of the module in the local bus

Subslot

Specify a subslot if you wish to access a submodule (e.g., IO-Link). Not used at present (= 0).

PDI object index

See module-specific data sheet.

PDI object subindex

See module-specific data sheet.

Number of PDI data bytes

For command code

0041_{hex} 0
 0042_{hex} Amount of data to be written in bytes

For message code

8041_{hex} Amount of data read in bytes
 8042_{hex} 0

Error class, error code

0000_{hex}: No error
 ≠ 0000_{hex}: An error has occurred; negative response
 ID of error message

Additional code

More detailed information about the error cause.

Should an error occur, the error message details the error class, error code, and additional code.



For the meaning of the error codes for the Axioline F bus errors and Axioline F I/O errors, please refer to the AXL F SYS DIAG user manual.

18.3 Example: read PDI object

The PDI read service can be conveniently used with the Modbus function code FC23 (read/write).

Alternatively, you can use FC16 (write) and FC3 (read).

The contents of the VendorID object (manufacturer identification) of the first module should be read after the first bus coupler.

To this end, PDI channel 1 (6010/6210) should be used.

Read request

Write the following values via FC16 or FC23 to register 6010 and onwards.

Modbus address	Byte	Con-tents (hex)	Meaning	
6010	0	00	Command code	Read PDI object
	1	41		
6011	2	00	Slot	1st local bus device
	3	01		
6012	4	00	Subslot	No subslot
	5	00	Reserved	Reserved
6013	6	00	PDI object index	0002 _{hex} : VendorID (manufacturer identification)
	7	02		
6014	8	00	Subindex	No subindex
	9	00	Number of PDI data bytes	Read, therefore = 00

Response

The result is provided in register 6210 and onwards.

As described before, register 6215 has an internal "virtual length". Use a Modbus function code for access to the registers marked with *, which allow access to multiple registers in one request. Register 6210 functions as the start address; 125 can always be used as the register number in the case of read access.

- Positive response

Modbus address	Byte	Con- tents (hex)	Meaning	
6210	0	80	Message code	Response to "Read PDI object"
	1	41		
6211	2	00	Slot	Copy of request
	3	01		
6212	4	00	Subslot	Copy of request
	5	00	Reserved	
6213	6	00	PDI object index	Copy of request
	7	02		
6214	8	00	Subindex	Copy of request
	9	07	Number of PDI data bytes	7 bytes of data read
6215	10	00	Error class	No error
	11	00	Error code	
6216*	12	30	Read data	00A045 (7 bytes, including zero terminator; ASCII coded)
	13	30		
6217*	14	41		
	15	30		
6218*	16	34		
	17	35		
6219*	18	00		
	19	00		

- Negative response

Modbus address	Byte	Con- tents (hex)	Meaning	
6210	0	80	Message code	Response to "Read PDI object"
	1	41		
6211	2	00	Slot	Copy of request
	3	01		
6212	4	00	Subslot	Copy of request
	5	00	Reserved	
6213	6	00	PDI object index	Copy of request
	7	02		
6214	8	00	Subindex	Copy of request
	9	00	Number of PDI data bytes	Error message, therefore = 0
6215	10	xx	Error class	Error message
	11	xx	Error code	
6216*	12	xx	Additional error code	
	13	xx		

18.4 Example: write to PDI object

The PDI write service can be conveniently used with the Modbus function code FC23 (read/write).

Alternatively, you can use FC16 (write) and FC3 (read).

All process data channels of the AXL F AI4 I 1H module should be parameterized.

In the physical bus configuration, the module is the second module.

The parameterization is performed via the ParaTable object (0080_{hex}).

PDI channel 3 (6030/6230) should be used.

Write request

Write the following values via FC16 or FC23 to register 6030 onwards.

As described before, register 6035 has an internal “virtual length”. Use a Modbus function code for access to the registers marked with *, which allow access to multiple registers in one request. Register 6030 functions as the start address; the total length must be specified as a register number. In the example, the total length is 11 (register 6030 to 6040).

Modbus address	Byte	Contents (hex)	Meaning		
6030	0	00	Command code	Write PDI object	
	1	42			
6031	2	00	Slot	2nd local bus device	
	3	02			
6032	4	00	Subslot	No subslot	
	5	00	Reserved	Reserved	
6033	6	00	PDI object index	0080 _{hex} : ParaTable (parameter table)	
	7	80			
6034	8	00	Subindex	No subindex	
	9	0C	Number of PDI data bytes	12 bytes (length of the parameter table)	
6035	10	00	Data byte 0	According to the module-specific data sheet: For each of the four channels: Filter 30 Hz, 16-sample average value, Measuring range 0 mA ... 20 mA	
	11	04	Data byte 1		
6036*	12	00	Data byte 2		
	13	04	Data byte 3		
6037*	14	00	Data byte 4		
	15	04	Data byte 5		
6038*	16	00	Data byte 6		
	17	04	Data byte 7		
6039*	18	00	Data byte 8		According to the module-specific data sheet: Data format IB IL
	19	00	Data byte 9		
6040*	20	00	Data byte 10		According to the module-specific data sheet: Reserved
	21	00	Data byte 11		

Response

The result is provided in register 6230 onwards.

As described before, register 6235 has an internal “virtual length”. Use a Modbus function code for access to the registers marked with *, which allow access to multiple registers in one request. Register 6230 functions as the start address; 125 can always be used as the register number in the case of read access.

- Positive response

Modbus address	Byte	Con- tents (hex)	Meaning	
6230	0	80	Message code	Response to "Write PDI object"
	1	42		
6231	2	00	Slot	Copy of request
	3	02		
6232	4	00	Subslot	Copy of request
	5	00	Reserved	
6233	6	00	PDI object index	Copy of request
	7	80		
6234	8	00	Subindex	Copy of request
	9	00	Number of PDI data bytes	For write access = 0
6235	10	00	Error class	No error
	11	00	Error code	
6236*	12	00	PDI data	Not available for write access to the confirmation, for this reason = 0
	13	00		
...	...	00		

- Negative response

Modbus address	Byte	Con- tents (hex)	Meaning	
6230	0	80	Message code	Response to "Write PDI object"
	1	42		
6231	2	00	Slot	Copy of request
	3	02		
6232	4	00	Subslot	Copy of request
	5	00	Reserved	
6233	6	00	PDI object index	Copy of request
	7	80		
6234	8	00	Subindex	Copy of request
	9	00	Number of PDI data bytes	Error message, therefore = 0
6235	10	xx	Error class	Error message
	11	xx	Error code	
6236*	12	xx	Additional error code	
	13	xx		

18.5 Exception Codes

In order to increase user comfort, the main problems that can occur when accessing the PDI channel are indicated directly via a Modbus exception. In addition to the standard exception codes (01 ... 04; see Modbus specification), some user-defined exception codes have been defined specifically for PDI channel handling.

Designation	Exception Code		Meaning/cause
	dec	hex	
ILLEGAL_FUNCTION	1	1	General
ILLEGAL_DATA_ADDRESS	2	2	General
ILLEGAL_DATA_VALUE	3	3	Write to data register (60x5) even though PDI read was selected in the "Service command code" field. PDI length (register 60x4; length of the data to be written in bytes) does not match the actual length.
DEVICE_FAILURE	4	4	Internal failure (e.g., maximum number of connections exceeded) Device cannot be reached (timeout)
MBUS_PDI_ERR_DOUBLE_USE_CH	16	10	An attempt was made to use the same communication channel with multiple TCP connections. An attempt was made to use a communication channel used with a TCP connection via UDP.
MBUS_PDI_ERR_ILLEGAL_SVC_CODE	17	11	The "Service code" field (register 60x0) does not contain a valid service code. 0041 _{hex} is valid for PDI_Read and 0042 _{hex} for PDI_Write.
MBUS_PDI_ERR_USER_PROBLEM	18	12	An error occurred on a PDI_Write request (triggered by writing to register 60x5). For additional information, refer to the confirmation (register 62xx).
MBUS_PDI_ERR_INVALID_DATA	19	13	No valid confirmation that can be read via the confirmation table (register 62xx). In this case, an access attempt returns the specified exception.

19 Simple Network Management Protocol - SNMP

The bus coupler supports SNMP v1 and v2c.

Management Information Base - MIB



The corresponding latest MIBs are available on the Internet at phoenixcontact.net/products.

For the object descriptions, please refer to the ASN1 descriptions for this product.

The password for read access is “public” and cannot be changed.

By default upon delivery, the password for write/read access is “private” and can be modified at any time.

20 WBM - Web-based management

The device has a web server, which generates the required pages for web-based management and, depending on the requirements of the user, sends them to a standard web browser.

Web-based management can be used to access static information (e.g., technical data, MAC address) or dynamic information (e.g., IP address, status information, local bus structure, and local bus diagnostics).

Calling web-based management

The device web server can be addressed using the IP address if configured accordingly. The homepage (web page) of the device is accessed by entering the URL “http://ip-address”.

Example: <http://172.16.113.38>

The default password is “private”.



If you cannot access the WBM pages, check the connection settings in your browser and deactivate the proxy, if set.

21 Firmware update

In order to update the firmware of the bus coupler, provide the bus coupler with a firmware container via a TFTP server or load it onto the bus coupler via FTP. Any FTP client or TFTP server can be used for this, e.g., the Factory Manager. If the Factory Manager is not used, initialize the firmware update via web-based management. When carrying out the firmware update, the RDY LED flashes yellow.



For detailed information on firmware update via TFTP, please refer to application note TFTP FIRMWARE UPDATE AXL F BK.



SCATTERGOOD & JOHNSON LTD

ELECTRICAL ENGINEERING & FLUID CONTROL DISTRIBUTORS

Est.1899

At Scattergood & Johnson Ltd, we pride ourselves on being a technical distributor to specialist industries.

Working with a range of quality product suppliers across a number of specialist markets, we are not your average 'box shifter' - we are your technical and supply chain partner.

We fully support every product we sell - for free! Our internal team and external sales engineers can answer any product or application question, no matter the complexity.

Backing up this technical ability is a range of 50,000+ products available from stock for nationwide next day delivery (same day if required!), or you can collect what you need from any of our trade counters around the UK.

Select your specialist interest below to learn more about how we can help.

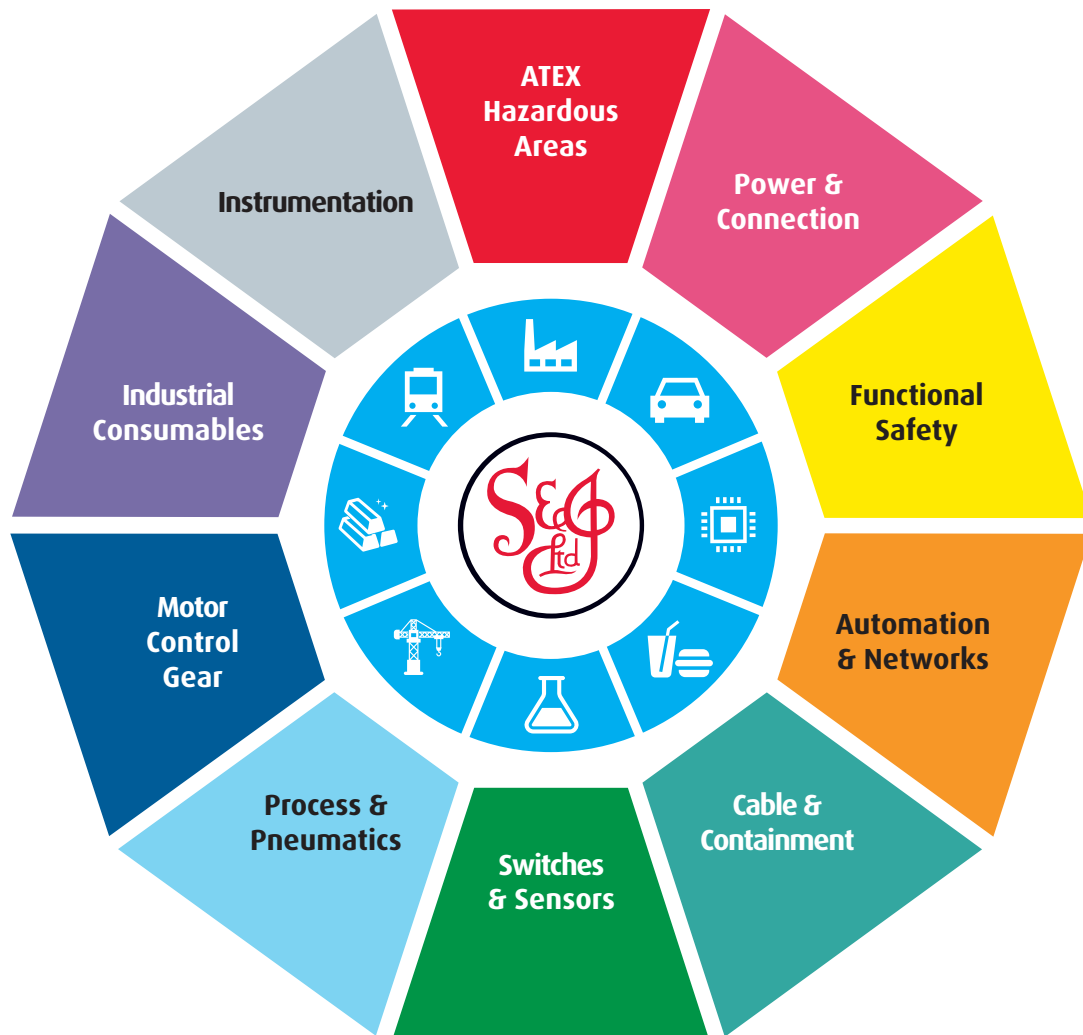

Online, In Branch and On the Road - Scattergood & Johnson Ltd, there when you need us.

www.scatts.co.uk