

# Axioline F: system and installation

User manual



## **User manual**

# **Axioline F: system and installation**

UM EN AXL F SYS INST, Revision 08

2019-11-18

---

This user manual is valid for:

All modules of the Axioline F product group without bus-specific special features.

7982\_en\_08

---

# Table of contents

1	For your safety .....	8
	1.1 Identification of warning notes .....	8
	1.2 Qualification of users .....	8
	1.3 Intended use.....	8
	1.4 Product changes .....	9
2	Documentation landscape of Axioline F.....	10
	2.1 Available documents .....	10
	2.2 Documentation on the Internet .....	12
	2.3 Purpose of this user manual .....	12
3	The Axioline F product group.....	13
	3.1 Axioline F – the block-based modular I/O system .....	13
	3.2 Structure of an Axioline F station .....	14
	3.3 Product description.....	15
	3.4 Approvals .....	19
4	Axioline F modules at a glance .....	21
	4.1 Axioline F order designation .....	21
	4.2 Controller.....	23
	4.3 Bus coupler .....	24
	4.4 Input and output modules .....	25
	4.4.1 Overview .....	25
	4.4.2 Extreme conditions version (XC) .....	26
	4.4.3 Safety modules with safe digital inputs or outputs .....	27
	4.5 Power module for the communications power $U_{BUS}$ .....	27
	4.6 Master .....	27
	4.7 Backplane for Axioline Smart Elements.....	27
5	Housing versions, design, and dimensions.....	28
	5.1 Housing versions .....	28
	5.2 Basic design of Axioline F modules .....	30
	5.2.1 Class 3000 AXC controller .....	30
	5.2.2 Class 2000 AXC F controller .....	31
	5.2.3 Bus coupler and class 1000 AXC controller .....	32
	5.2.4 I/O module (electronics module) .....	33

**UM EN AXL F SYS INST**

5.3	Axioline F module dimensions .....	34
5.3.1	AXC controller and bus coupler .....	34
5.3.2	I/O modules for the 24 V area .....	35
5.3.3	I/O modules for the low voltage area .....	37
5.3.4	Power measurement module .....	38
5.4	Bus base modules .....	39
5.5	Axioline F connectors .....	40
5.5.1	Versions and dimensions .....	40
5.5.2	Basic design .....	41
5.6	Color and marking .....	42
<b>6</b>	<b>Transport, storage, and unpacking .....</b>	<b>45</b>
6.1	Transport .....	45
6.2	Storage .....	45
6.3	Unpacking .....	45
<b>7</b>	<b>Mounting and removing modules .....</b>	<b>46</b>
7.1	Safety notes for mounting and removal .....	46
7.1.1	General safety notes .....	46
7.1.2	Additional safety notes for the low voltage area .....	49
7.2	Basic information about mounting .....	50
7.3	Left alignment .....	53
7.4	Mounting the modules .....	53
7.4.1	Bus base modules, controllers, and bus couplers .....	54
7.4.2	I/O modules .....	55
7.5	Removing modules .....	56
7.5.1	Removing connectors or cables .....	56
7.5.2	Controller, bus coupler, and I/O modules .....	57
7.6	Removing or inserting a connector .....	59
7.6.1	Removing a connector .....	59
7.6.2	Inserting a connector .....	59
7.7	Replacing a module .....	59
7.8	Mounting distances .....	60
<b>8</b>	<b>Connecting or removing cables .....</b>	<b>62</b>
8.1	Connections and cables in the Axioline F system .....	62
8.2	Conductor cross sections and stripping and insertion lengths .....	63
8.3	Terminal point, associated spring lever, and associated touch connection .....	65
8.4	Connecting unshielded cables .....	66
8.5	Connecting shielded cables .....	67
8.6	Removing cables from the terminal point .....	68

**Table of contents**

8.7	Connecting the power supplies .....	69
8.7.1	Axioline F system supply .....	69
8.7.2	Power supply requirements .....	70
8.7.3	Supply at the controller or bus coupler .....	70
8.7.4	Supply at the power module .....	70
8.7.5	Supply at the I/O modules .....	71
8.7.6	Jumpers in power connectors, potential forwarding, and fusing .....	71
8.7.7	Parallel supply .....	72
8.8	Connecting the network.....	72
8.9	Connecting the USB cable to the USB interface.....	73
8.10	Connecting sensors and actuators .....	74
8.10.1	Connection technology for sensors and actuators .....	74
8.10.2	Connections used for low-level signal digital I/O modules .....	75
8.10.3	Connecting digital sensors and actuators using different connection technologies .....	76
8.10.4	FLK .....	79
8.10.5	Redundant signals .....	80
9	Grounding and shielding.....	82
9.1	Grounding concept.....	82
9.1.1	Protective ground (PE) .....	82
9.1.2	Functional ground (FE) .....	83
9.2	Shielding concept .....	84
9.2.1	Shielding with Axioline F .....	84
9.2.2	Shielding when connecting analog sensors and actuators .....	84
9.2.3	Connecting the shield using the Axioline F shield connection set .....	85
9.2.4	Connecting the shielding to a busbar .....	89
9.2.5	Integrating analog shielding in a concept with central equipotential bonding at the control cabinet entry .....	90
10	Diagnostic and status indicators .....	91
10.1	Indicators on controllers .....	91
10.2	Indicators on bus couplers.....	92
10.3	Indicators on I/O modules.....	94
10.3.1	LEDs on the power connectors .....	94
10.3.2	LEDs on the I/O connectors .....	96
10.4	Reporting diagnostics via PDI.....	96

**UM EN AXL F SYS INST**

<b>11</b>	<b>Axioline F backplane.....</b>	<b>97</b>
11.1	Housing versions.....	97
11.2	Basic design.....	98
11.3	Dimensions.....	99
11.3.1	Dimensions of the backplanes .....	99
11.3.2	Dimensions of the backplanes with inserted Smart Elements .....	100
11.4	Color and marking.....	101
11.5	Mounting and removing the backplane.....	103
11.5.1	Safety notes for mounting and removal .....	103
11.5.2	Basic information about mounting .....	103
11.5.3	Mounting the backplane and Smart Elements .....	104
11.5.4	Removing the backplane .....	107
11.5.5	Replacing the backplane .....	109
11.5.6	Mounting distances .....	109
11.6	Connecting and removing cables .....	110
11.6.1	Connections and cables at an Axioline F backplane .....	110
11.6.2	Conductor cross sections and stripping and insertion lengths .....	110
11.6.3	Connecting cables .....	112
11.6.4	Removing cables from the terminal point .....	113
11.7	Power supplies .....	114
11.7.1	Supplying the Axioline F system with Axioline F backplanes .....	114
11.7.2	Supply at the Axioline F backplane .....	115
11.7.3	Jumpers, potential forwarding, and fusing .....	115
11.8	Grounding and shielding.....	116
11.9	Diagnostic and status indicators.....	117
<b>12</b>	<b>Process, parameter, and diagnostic data.....</b>	<b>119</b>
12.1	Process data .....	119
12.2	Parameter and diagnostic data (PDI channel) .....	119
12.3	Saving of parameters .....	120
<b>13</b>	<b>Software support .....</b>	<b>121</b>
13.1	Overview of the software .....	121
13.2	Project+ .....	121
13.3	PROJECT complete .....	121
13.4	Startup+ .....	122
13.5	PC Worx .....	122
13.6	PLCnext Engineer .....	122

**Table of contents**

14	Device replacement, device defect and repair .....	123
	14.1 Device replacement.....	123
	14.2 Device defect and repair.....	123
15	Maintenance, decommissioning, and disposal .....	124
	15.1 Maintenance.....	124
	15.2 Decommissioning and disposal.....	124
16	Technical data and ordering data .....	125
	16.1 Technical data.....	125
	16.2 Ordering data .....	130
A	Technical appendix: communication objects (PDI objects).....	136
	A 1 General standard objects .....	137
	A 1.1 Objects for identification .....	137
	A 1.2 Objects for diagnostics .....	140
	A 1.3 Objects for process data management .....	142
	A 1.4 Objects for device management .....	143
	A 1.5 Objects for object descriptions .....	146
	A 1.6 Objects for energy management .....	146
	A 1.7 Objects for modular devices .....	146
	A 2 Manufacturer-specific application objects .....	147
	A 3 Value ranges .....	147
	A 4 Function blocks for access to the objects under PC Worx.....	147
B	Technical appendix: Altitude, times, synchronization, substitute value behavior, and power-on behavior.....	148
	B 1 Use of Axioline F modules at an elevation of more than 3000 meters.....	148
	B 2 Transmission speed .....	149
	B 3 Typical cycle time on the local bus .....	149
	B 4 Response times for an Axioline F system .....	150
	B 5 Synchronization.....	152
	B 5.1 Synchronization in general .....	152
	B 5.2 Synchronization options .....	154
	B 5.3 Conditions for local bus synchronization .....	154
	B 6 Substitute value behavior and power-on behavior.....	155
C	Index.....	156
D	Revision history .....	159

# 1 For your safety

Read this user manual carefully and keep it for future reference.

## 1.1 Identification of warning notes



This symbol indicates hazards that could lead to personal injury.

There are three signal words indicating the severity of a potential injury.

### **DANGER**

Indicates a hazard with a high risk level. If this hazardous situation is not avoided, it will result in death or serious injury.

### **WARNING**

Indicates a hazard with a medium risk level. If this hazardous situation is not avoided, it could result in death or serious injury.

### **CAUTION**

Indicates a hazard with a low risk level. If this hazardous situation is not avoided, it could result in minor or moderate injury.



This symbol together with the **NOTE** signal word warns the reader of actions that might cause property damage or a malfunction.



Here you will find additional information or detailed sources of information.

## 1.2 Qualification of users

The use of products described in this user manual is oriented exclusively to electrically skilled persons or persons instructed by them. The users must be familiar with the relevant safety concepts of automation technology as well as applicable standards and other regulations.

## 1.3 Intended use

Axiline F controllers, bus couplers, and I/O modules should only be used according to the instructions in the module-specific documentation and this user manual. Phoenix Contact accepts no liability if the device is used for anything other than its designated use.

## **1.4 Product changes**

Modifications to hardware and firmware of the device are not permitted.

Incorrect operation or modifications to the device can endanger your safety or damage the device. Do not repair the device yourself. If the device is defective, please contact Phoenix Contact.

## 2 Documentation landscape of Axioline F

### 2.1 Available documents

The documentation for the Axioline F product group is modular, providing you with the optimum information to meet your requirements.



In the following table, the term “module” is used for the controller, bus coupler, and I/O module.

Table 2-1 Axioline F documentation

Document	Contents
<b>System: information on the Axioline F system</b>	
User manual “Axioline F: system and installation” UM EN AXL F SYS INST (this manual)	This manual is the generic system manual for Axioline F.  It describes the Axioline F product group and everything about mounting, removing and wiring the Axioline F modules, regardless of a higher-level network.
User manual “Axioline F: diagnostic registers and error messages” UM EN AXL F SYS DIAG	The user manual lists all error messages for the system and provides remedial measures.
<b>Module: basic information on a specific module</b>	
Packing slips	A packing slip is provided with the module upon delivery. It contains key information for the electrical installation of a module or group of modules. This includes, for example: <ul style="list-style-type: none"> <li>– Short description</li> <li>– Safety notes</li> <li>– Mounting and removal</li> <li>– Terminal point assignment</li> </ul>
User manuals for safety modules and controllers	The user manual for each safety module or controller contains the complete information needed for use.  This includes at the very least: <ul style="list-style-type: none"> <li>– Description</li> <li>– Mounting, removal and power supply</li> <li>– Startup under PC Worx</li> <li>– Technical data and ordering data</li> </ul>

## Documentation landscape of Axioline F

Table 2-1 Axioline F documentation [...]

Document	Contents
Module-specific data sheets	<p>The data sheet for each module contains the complete information needed for use.</p> <p>This includes at the very least:</p> <ul style="list-style-type: none"> <li>- Function description</li> <li>- Accessories</li> <li>- Technical data</li> <li>- Connection assignment or terminal point assignment</li> <li>- Local diagnostic and status indicators</li> <li>- Connection examples</li> </ul>
<b>Additional: information on a specific module</b>	
Additional user manuals	<p>The additional user manuals either describe:</p> <ul style="list-style-type: none"> <li>- A bus coupler connected to a network or</li> <li>- A specific module</li> </ul> <p>Each user manual only describes the relevant module and/or bus-specific special features. Being a generic manual, the UM EN AXL F SYS INST user manual also applies.</p>
Quick start guides	Quick start guides are available for various topics. A quick start guide describes the startup of a system or module step by step using an example.
Application notes	Application notes provide additional information about special topics.
<b>Up-to-date pdf</b>	
Generate product PDF	<p>By clicking the "Generate product PDF" button on the Internet, you can access up-to-date information on the product (see <a href="#">Section "Documentation on the Internet" on page 12</a>).</p> <p>This includes at the very least:</p> <ul style="list-style-type: none"> <li>- Short description</li> <li>- Technical data</li> <li>- Drawings</li> <li>- Approvals</li> </ul>

## 2.2 Documentation on the Internet

The documentation can be downloaded at [phoenixcontact.net/products](http://phoenixcontact.net/products). Here you will find information on each product. During your search, take into account the difference between “Generate product PDF” and “Downloads”.

### Generate product PDF

Click the “Generate product PDF” button to receive selected up-to-date information. It provides a **short overview** of the module.

The generated PDF file contains the essential product information. If you require further information, you can use the “Downloads” tab.

### Downloads

On the “Downloads” tab, you can access the **complete** documentation and all other downloads related to a module.

Module-specific documentation can be found in the download area for the corresponding module.

Comprehensive documentation can be found in the download area for the bus coupler.

## 2.3 Purpose of this user manual

This user manual informs you about the Axioline F system. It describes the system and everything about Axioline F module mounting and wiring regardless of a higher-level network.

## 3 The Axioline F product group

### 3.1 Axioline F – the block-based modular I/O system

Axioline F is a modular I/O system for the control cabinet. Open to all Ethernet-based communication protocols and available in various designs, Axioline F offers maximum flexibility.

#### Your advantages

- Increased machine output, thanks to particularly fast and synchronous signal acquisition
- Particularly robust mechanics, shock and vibration resistance withstand even the most adverse conditions and increase system availability
- Installation time is reduced, thanks to fast wiring and easy handling
- The Axioline F I/O system is part of the COMPLETE line system
- Can be used with Phoenix Contact controllers or in all common networks with a corresponding bus coupler
- Implement safety applications with PROFIsafe or SafetyBridge Technology

## 3.2 Structure of an Axioline F station

An Axioline F station consists of individual modules, which are snapped onto a DIN rail. A controller or a bus coupler forms the head of the station. I/O modules are mounted next to it.

Bus base modules are used for connecting the individual Axioline F modules to one another and to the station head. The bus base modules are snapped onto the DIN rail side by side and thus form the Axioline F local bus.

You can integrate Axioline Smart Elements into an Axioline F station by means of an Axioline F backplane.

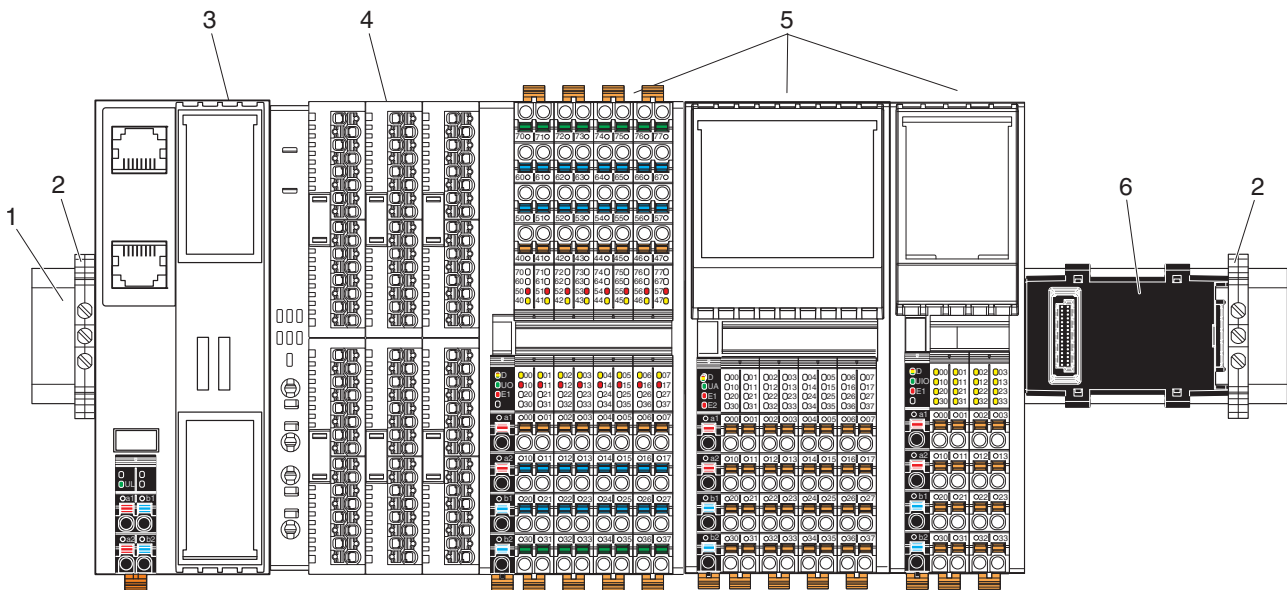

Figure 3-1 Example of an Axioline F station

- 1 DIN rail
- 2 End bracket (for securing the station; see [“End brackets” on page 51](#))
- 3 Bus head (bus coupler or controller)
- 4 Axioline F backplane with Axioline Smart Elements
- 5 Axioline F input or output modules
- 6 Bus base module



For detailed information regarding the function, properties, wiring, and parameterization, please refer to the module-specific documentation.



For detailed information regarding the Axioline F backplane, refer to [Section “Axioline F backplane” on page 97](#).

### 3.3 Product description

Axioline F modules with various functions are available within the Axioline F product group. Additionally, Axioline F backplanes are available, which you can use to integrate Axioline Smart Elements with different functions into an Axioline F station.

#### Axioline F backplane

The Axioline backplanes are described in detail in [Section “Axioline F backplane” on page 97](#).

#### Axioline F modules

The Axioline F modules consist of an electronics module, one or several connectors, and a bus base module.

The electronics module can be changed without having to remove a wire from the connector.

The bus base modules are snapped onto the DIN rail side by side and thus form the Axioline F local bus that connects the modules to one another.



The Axioline F local bus is subsequently referred to as the local bus.

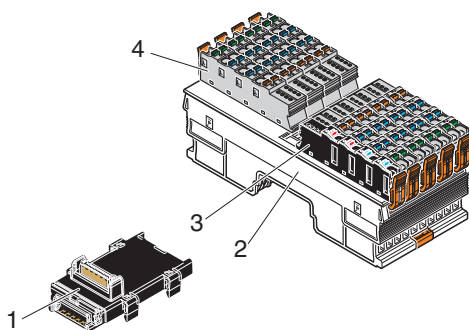

Figure 3-2 Components of an Axioline F I/O module

Key:

- 1 Bus base module
- 2 Electronics module
- 3 Connector for connecting the supply voltage
- 4 I/O connector

#### Versions

Modules are available for the following automation tasks:

- Controllers
- Bus couplers to integrate the Axioline F station into various networks (PROFINET, Ser-cos, PROFIBUS, etc.).
- Input and output modules for digital and analog signals
- Modules for temperature measurement
- Modules for open and closed-loop control, and position detection
- Modules for communication
- ...

This product range is growing continuously.

## UM EN AXL F SYS INST

### Voltage ranges

Axioline F modules are available for the protective extra-low voltage range and the low voltage range. You can use low-voltage modules and extra-low voltage modules directly next to each other within an Axioline F station.

Table 3-1 Voltage ranges for Axioline F

Voltage range	Product groups	Nominal voltage used	Permissible voltage range	Examples
Protective extra-low voltage	Low-level signal modules	24 V DC	19.2 V DC ... 30 V DC	AXL F DI16/4 2F
		48 V DC, 60 V DC	-100 V DC ... 100 V DC	AXL F DI8/2 48/60DC 1F
Low voltage	Low-voltage modules	110 V DC/ 220 V DC	-300 V DC ... 300 V DC	AXL F DI8/2 110/220DC 2F
		220 V DC 230 V AC	-300 V DC ... 300 V DC 24 V AC ... 230 V AC (50 Hz ... 60 Hz)	AXL F DOR4/2 AC/220DC 1F
		230 V AC	12 V AC ... 253 V AC (50 Hz ... 60 Hz)	AXL F DO4/3 AC 1F



The instructions given in this user manual and in the module-specific documentation must be followed during installation and startup.

Particularly observe:

[Section "Safety notes for mounting and removal" on page 46.](#)

### Mounting location

The Axioline F modules meet IP20 degree of protection and can be used in closed control cabinets or control boxes (junction boxes) with IP54 degree of protection according to EN 60529 or higher.

The compact design means that the Axioline F modules can be installed in standard junction boxes. Please observe the mounting distances when selecting the housing, see [Section "Mounting distances" on page 60.](#)

### Mounting

Each Axioline F module consists of a bus base module and an electronics module. Snap the bus base modules onto the DIN rail without the need for tools and arrange the modules side by side. The local bus is created automatically when the bus base modules are installed next to one another.

Then, snap the electronics modules onto the DIN rail over the bus base modules.

See [Section "Mounting and removing modules" on page 46.](#)

### Removal

Only a standard tool is necessary for removing the electronics module (e.g., a bladed screwdriver with a blade width of 2.5 mm).

See [Section "Mounting and removing modules" on page 46.](#)

### Bus connection (network)

The Axioline F station is integrated in the network using a controller or a bus coupler.

---

<b>Axioline F local bus</b>	<p>There is an interface to the Axioline F local bus on the bottom of the modules. Bus base modules are used to carry the communications power and the bus signals from the controller or bus coupler through the Axioline F station. The bus base module is supplied as standard with each module.</p> <p>The maximum number of Axioline F modules within a station is 63. The actual number of modules within an Axioline F station may be limited by the supplied logic current, the current consumption of the connected modules, and the system limits of the controller or bus coupler. See <a href="#">Section “Maximum number of modules” on page 52</a>.</p>
<b>Connectors</b>	<p>Axioline F modules have connectors for connecting the power supply and the I/O. The connectors have spring-cage terminal blocks. Suitable conductors can be connected with Push-in technology (see <a href="#">Section “Conductor cross sections and stripping and insertion lengths” on page 63</a>).</p>
<b>Connecting the supply voltage</b>	<p>The communications power for the Axioline F station is supplied at the controller or bus coupler. The voltage for the module’s I/O is supplied separately to each I/O module (see <a href="#">Section “Connecting the power supplies” on page 69</a>).</p>
<b>I/O connection</b>	<p>Sensors and actuators are connected using connectors (see <a href="#">Section “Connecting sensors and actuators” on page 74</a>).</p> <p>Depending on the module, the sensor/actuator cables are connected in one direction (at the bottom) or in two directions (at the top and at the bottom).</p>
<b>FE connection</b>	<p>On the bottom of each module, there is at least one FE spring (metal contact) which establishes the connection to functional ground when the module is snapped onto a grounded DIN rail.</p>
<b>Programming interface, service interface</b>	<p>On the controllers and bus couplers, there is a USB interface that can be used as programming interface or service interface. In addition to providing the network interface, it enables communication with the controller or bus coupler from a PC.</p>
<b>Startup+</b>	<p>For information on Startup+, please refer to <a href="#">Section 13, “Software support”</a> and the corresponding documentation.</p>
<b>Web-based management</b>	<p>By means of the web-based management integrated into the controllers and some bus couplers, you have the option to display static and dynamic information of the controller using a standard browser. The status and diagnostic functions can be displayed on a graphical user interface by means of read access via a device network connection. In addition, specific controller/bus coupler properties can be configured via web-based management.</p>

## UM EN AXL F SYS INST

---

### Diagnostics

The Axioline F system provides comprehensive diagnostics:

- Remote diagnostics
- Process diagnostics (e.g., cycle time monitoring)
- Communication diagnostics
- Module diagnostics (status of Axioline F module)
- I/O diagnostics (status of sensors/actuators)

For the diagnostic options of a specific module, please refer to the module-specific data sheets.

### Reset button

The reset button provided on the controllers and bus couplers can only be operated with a pointed object (e.g., a pen) and is therefore protected against accidental activation.

If the reset button is actuated during operation, the controller or bus coupler is restarted.

Using the reset button, the controller or bus coupler can also be reset to the default settings.



For more detailed information on the reset button, please refer to the module-specific documentation.

### Parameterization memory (controller)

The controllers have an integrated parameterization memory. Alternatively, it is possible to use a pluggable parameterization memory in the form of an SD card or USB stick.



For more detailed information on the parameterization memory, please refer to the user manual for the controller used.

### 3.4 Approvals

For the latest approvals for a module, please visit [phoenixcontact.net/products](http://phoenixcontact.net/products).



Observe any notes and restrictions on the approvals in the module-specific packing slip or in the module-specific documentation.

#### Searching for approvals of a product

When searching for the approvals of a specific product, please proceed as follows:

- Enter the order designation, a part of it, or the order number in the search window.



Figure 3-3 Searching for order number 2688310

- Select the product.
- Switch to the “Approvals” tab.

The current approvals of the product are listed.

I/O module - AXL F DI16/1 1H - 2688310

Axioline F digital input module, 16 inputs, 24 V DC, 1-wire connection method (including bus base module and connectors)

Generate product PDF

Available

PHOENIX CONTACT  
586 Fulling Mill Road  
Middletown, PA 17057  
(800) 888-7388  
E-mail  
Your local sales contact

Add to comparison Add to part list Find a distributor Add to wish list

Technical data Accessories FAQs **Approvals** Downloads

Approvals  
UL Listed / cUL Listed / EAC / cULus Listed

Approval details

UL Listed <http://database.ul.com/cgi-bin/XYW/template/LISEXT/1FRAME/index.htm> FILE E 140324  
Back to top

cUL Listed <http://database.ul.com/cgi-bin/XYW/template/LISEXT/1FRAME/index.htm> FILE E 140324  
Back to top

EAC  
Back to top

cULus Listed  
Back to top

Figure 3-4 Current approvals of product 2688310

## UM EN AXL F SYS INST

### Searching for all products that have a specific approval

When searching for products that have a specific approval, e.g., GL or ATEX-approved products, proceed as follows:

- Enter AXL F, for example, in the search window.



Figure 3-5 Searching for AXL F

- UL approvals are listed directly; for other approvals, open “Approval, More Options”.
- Activate the check box of the required approval and confirm the selection with “Submit”.

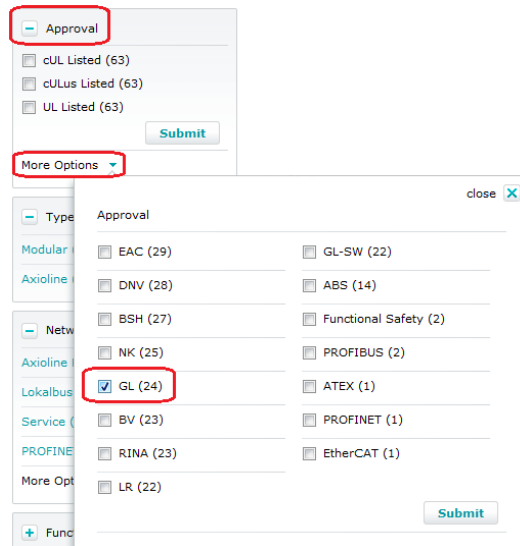

Figure 3-6 Selecting GL approval

This results in a list of all modules that have the selected approval.

## 4 Axioline F modules at a glance

### 4.1 Axioline F order designation

The order designation helps you to identify the function of a module.

Examples:	Product group	Function and number of inputs or outputs	Wire connection	Function extension	Housing
	AXL F	BK		PB	
	AXL F	DI16	/1	HS	1H
	AXL F	DI16	/4		2F
	AXL F	AI4		I	1H
	AXL F	DO8	/2	2A	1H
	AXL F	PSDO8	/3		1F
	AXL F	DO4	/3	AC	1F
	AXL F	DOR4	/2	AC/220DC	1F
	AXL F	DI8	/2	110/220DC	1F
	AXL F	BP		SE6	

Table 4-1 Structure of the order designations

<b>Product group</b>	AXL F	Axioline F
	AXC	Axioccontrol for the direct control of Axioline F I/Os
	AXC F	PLCnext Control for direct control of Axioline F I/Os
<b>Function</b>	BK	Bus coupler
	DI	Digital input
	DO	Digital output
	DOR	Relay output
	SDI	Safe digital input
	SDO	Safe digital output
	P(SDI, SDO)	PROFIsafe
	AI	Analog input
	AO	Analog output
	RTD	Analog input for the connection of resistance temperature detectors
	UTH	Analog input for the connection of thermocouple sensors
	CNT	Counter
	INC	Incremental encoder input
	SSI	SSI interface for absolute encoders
	RS UNI	Communication module for serial data transmission via RS-232 or RS-485/422
	PWR	Supply

## UM EN AXL F SYS INST

Table 4-1 Structure of the order designations [...]

<b>Function</b>	PM	Power measurement
	MA	Master
	IOL	IO-Link
	SGL	Strain gauge acquisition
	PWM	Pulse width modulation
	XT ETH	Left-alignable Ethernet interface
	XT IB	Left-alignable INTERBUS master
	IL ADAPT	Inline adapter terminal
	BP	Backplane for accepting Smart Elements (AxioLine SE modules)
<b>Number of inputs or outputs</b>	1 ... 64	1 channel ... 64 channels
<b>Function extension (for bus couplers (BK): bus system/network)</b>	PN	PROFINET
	S3	Sercos
	PB	PROFIBUS DP
	EC	EtherCAT®
	ETH	Ethernet (Modbus/TCP)
	SAS	Ethernet (IEC 61850, MMS, and GOOSE)
	EIP	EtherNet/IP™
<b>Function extension (for controllers)</b>	1xxx	Performance class 1000
	3xxx	Performance class 3000
	2152	Performance class 2000
<b>Function extension (for other modules)</b>	HS	High speed
	XC	Extreme conditions (extreme ambient conditions)
	S	Speed
	I	Current
	U	Voltage
	2A	2 A outputs
	FLK	FLK connection
	AC	Low voltage range AC (nominal voltage 230 V AC)
	AC/220DC	Low voltage range AC and DC (nominal voltage 230 V AC, 220 V DC)
	110/220DC	Low voltage range DC (nominal voltage 110 V DC, 220 V DC)
	IB	INTERBUS
	DALI	DALI
	SE4	4 Smart Elements
	SE6	6 Smart Elements
<b>Connection technology (for controllers)</b>	1TX	1 Ethernet interface

Table 4-1 Structure of the order designations [...]

<b>Connection technology (for digital modules only)</b>	/4	4-wire technology
	/3	3-wire technology
	/2	2-wire technology
	/1	1-wire technology
<b>Housing</b>	1F	1 terminal field, F housing (wide housing), cable outlet at the bottom
	2F	2 terminal fields, F housing (wide housing), cable outlets at the bottom and top
	1H	1 terminal field, H housing (narrow housing), cable outlet at the bottom
	2H	2 terminal fields, H housing (narrow housing), cable outlets at the bottom and top

## 4.2 Controller

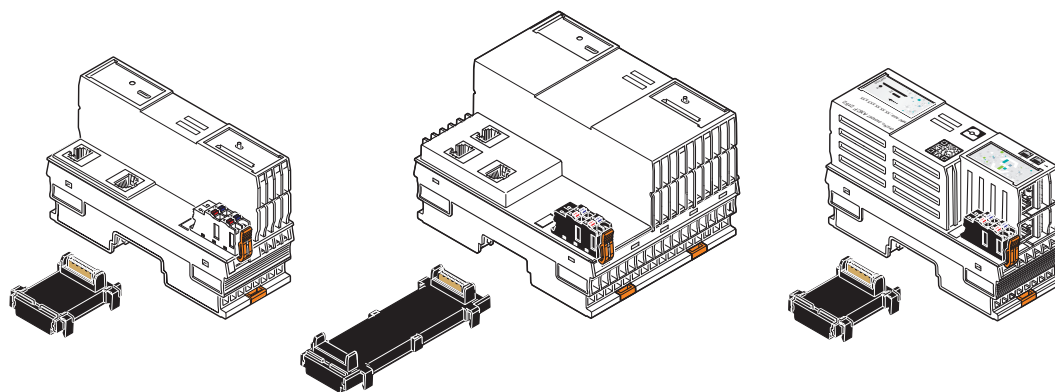

Figure 4-1 Example: AXC 1050, AXC 3050, and AXC F 2152

A controller is a modular control system with integrated Ethernet and Axioline F local bus connection. As the head of an Axioline F station, the controller provides the function of a control system.

Choose a class 1000 controller for small to medium-sized automation tasks and benefit from the Axioline F local bus, PROFINET, Modbus/TCP, and an integrated UPS, for example.

A class 3000 controller is the ideal controller for medium-sized to complex applications in which networking options as well as a particularly short processing and response speed are required.

The AXC F 2152 controller is fast, robust and easy to use. It is consistently designed for maximum performance, easy handling and use in harsh industrial environments.

### 4.3 Bus coupler

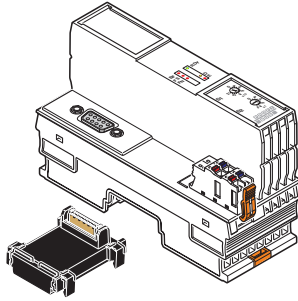

Figure 4-2 Example: AXL F BK PB

With a network and an Axioline F local bus connection, the bus coupler is the head of an Axioline F station and represents the link between your network and the Axioline F station.

Table 4-2 Supported bus systems/networks

Bus system/network	Bus coupler (examples)
PROFINET	AXL F BK PN TPS
PROFIBUS DP	AXL F BK PB
EtherNet/IP™	AXL F BK EIP
Ethernet (Modbus/TCP)	AXL F BK ETH
Ethernet IEC 61850	AXL F BK SAS
Sercos	AXL F BK S3
EtherCAT®	AXL F BK EC

## 4.4 Input and output modules

### 4.4.1 Overview

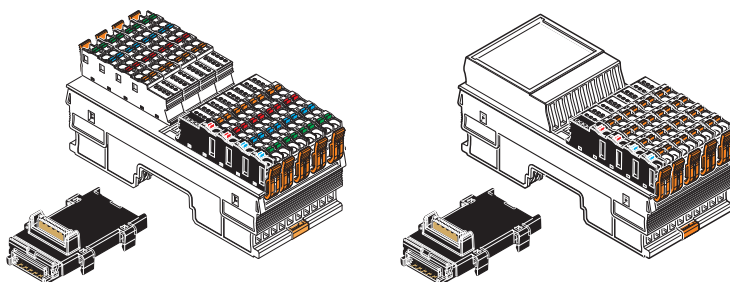

Figure 4-3 Example: AXL F DI16/4 2F and AXL F AO8 XC 1F

Modules are available with various functions. These include, for example, the modules listed below. The text in brackets indicates the function according to the order designation.

- Digital input and output modules (DI, DO, DOR)
- Analog input and output modules (AI, AO)
- Digital input and output modules for the low voltage range (220 DC, AC)
- Temperature measurement modules (RTD, UTH)
- Module for open and closed-loop control, and position detection (CNT/INC)
- Module for communication (RS, UNI)
- Function module (SSI1 AO1)
- Modules for use under extreme ambient conditions (XC versions, see [Section “Extreme conditions version \(XC\)” on page 26](#))
- Safety modules with safe digital inputs or outputs (PSDI, PSDO, see [Section “Safety modules with safe digital inputs or outputs” on page 27](#))
- Power module for the communications power  $U_{Bus}$  (see [Section “Power module for the communications power  \$U\_{Bus}\$ ” on page 27](#))
- ...

#### 4.4.2 Extreme conditions version (XC)

Thanks to special engineering measures and tests as well as partially coated PCBs, the XC modules can be used under extreme ambient conditions.

For use in the extended temperature range from  $-40^{\circ}\text{C}$  to  $+70^{\circ}\text{C}$ , please observe Section "Tested successfully: use under extreme ambient conditions" and the notes in the module-specific data sheet.

The function of an XC version is the same as the function of the corresponding standard version.

On the device rating plate for the XC version, the AXL F XC product range is stored in object 0006<sub>hex</sub>.

##### Tested successfully: use under extreme ambient conditions

XC modules have been tested successfully over 250 temperature change cycles according to IEC 61131-2 in the range from  $-40^{\circ}\text{C}$  to  $+70^{\circ}\text{C}$ .

The following conditions were observed:

- The Axioline F devices for all connecting cables were wired with a minimum conductor cross section of  $0.5\text{ mm}^2$
- The Axioline F station was mounted on a wall-mounted horizontal DIN rail
- Fans were used to ensure continuous movement of air in the control cabinet
- The Axioline F station was not exposed to vibration or shock
- The Axioline F station was operated with a maximum of 24.5 V (ensured by using electronically regulated power supply units)

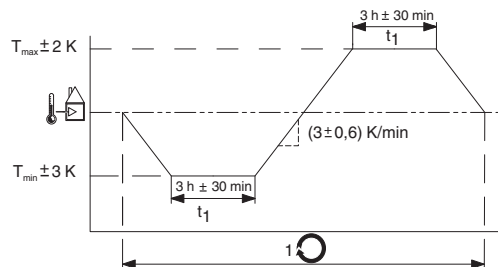

Figure 4-4 Temperature change cycle



Temperature in the control cabinet/ambient temperature



Cycle



Observe the information in the module-specific documentation.

### 4.4.3 Safety modules with safe digital inputs or outputs

The safety modules are to be used in an Axioline F station at any point in a safe system (e.g., PROFIsafe).

Depending on the version, the modules either have safe digital inputs or outputs. They can be parameterized according to the specific application, and enable the integration of sensors and actuators in the safe system.



For more detailed information on these modules, please refer to the module-specific user documentation.

## 4.5 Power module for the communications power $U_{Bus}$

If the maximum load of the controller or bus coupler for the Axioline F local bus supply (communications power  $U_{Bus}$ ) is reached, you can use this power module to provide this voltage again.

## 4.6 Master

Masters are used to integrate lower-level systems in the Axioline F station.

### Examples:

- |                   |   |
|-------------------|---|
| AXL F MA DALI2 1H | The 2-channel DALI master enables communication with two DALI networks including their bus power supply.  |
| AXC F XT IB       | The INTERBUS master is designed to be directly mounted to the left of an Axioline F controller.<br>The INTERBUS master can be used to integrate INTERBUS devices in the Axioline F station. |

## 4.7 Backplane for Axioline Smart Elements

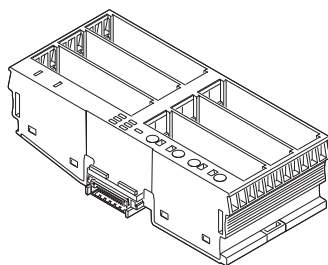

Figure 4-5 Example: AXL F BP SE6

The Axioline F backplanes are designed for use within an Axioline F station. The backplanes are designed to accept Axioline Smart Elements.

For information on the special features of the backplanes, refer to [Section “Axioline F backplane” on page 97](#).

# 5 Housing versions, design, and dimensions



If you use AxioLine F backplanes (AXL F BP SE4 or AXL F BP SE6), please observe [Section "AxioLine F backplane" on page 97](#).

## 5.1 Housing versions

Various housing versions are available in the AxioLine F portfolio; they are shown in [Figure 5-1](#).

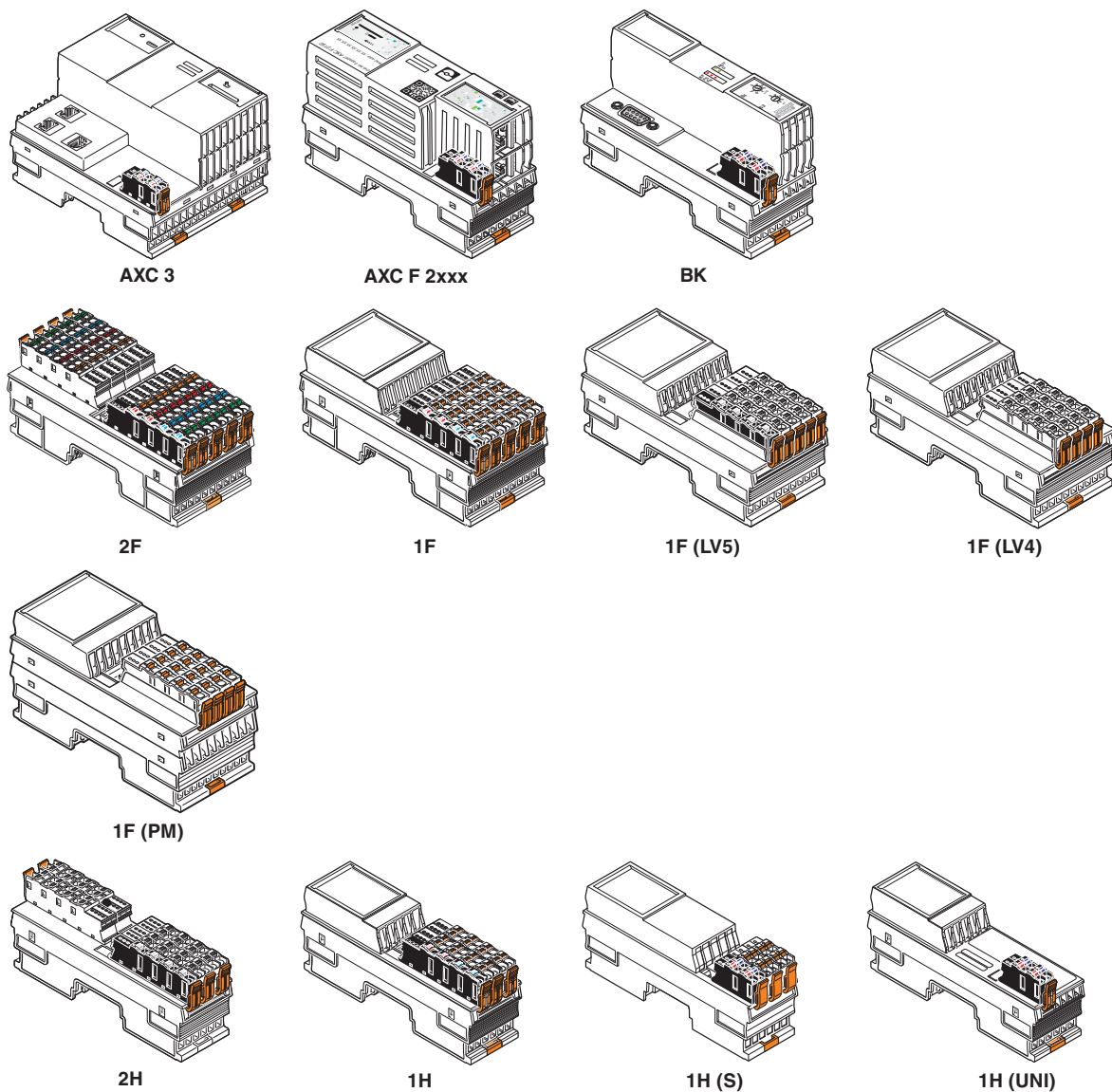

Figure 5-1 Housing versions

## Housing versions, design, and dimensions

Table 5-1 Housing versions

Housing type	Special feature	Example	Design	Dimensions
AXC 3	Class 3000 AXC controller	AXC 3050, AXC 3051	<a href="#">Figure 5-2 on page 30</a>	<a href="#">Figure 5-6 on page 34</a>
AXC F 2xxx	Class 2000 AXC F controller	AXC F 2152	<a href="#">Figure 5-3 on page 31</a>	<a href="#">Figure 5-7 on page 34</a>
BK	AXL F BK ... bus coupler Class 1000 AXC controller	AXL F BK PB, AXC 1050	<a href="#">Figure 5-4 on page 32</a>	<a href="#">Figure 5-8 on page 34</a>
2F	Wide housing, 2 terminal fields	AXL F DI16/4 2F AXL F DO16/3 2F	<a href="#">Figure 5-5 on page 33</a>	<a href="#">Figure 5-9 on page 35</a>
1F	Wide housing, 1 terminal field	AXL F AI8 XC 1F AXL F DI32/1 1F		<a href="#">Figure 5-10 on page 35</a>
1F (LVx)	Wide housing, 1 terminal field, low voltage			
1F (LV5)	5 connectors	AXL F DO4/3 AC 1F		<a href="#">Figure 5-16 on page 37</a>
1F (LV4)	4 connectors	AXL F DI8/2 110/220DC 1F AXL F DOR4/2 AC/220DC 1F		<a href="#">Figure 5-17 on page 37</a>
1F (PM)	Wide housing, 1 terminal field, power measurement	AXL F PM EF 1F		<a href="#">Figure 5-18 on page 38</a>
2H	Narrow housing, 2 terminal fields	AXL F DI16/1 DO16/1 2H AXL F DI32/1 2H		<a href="#">Figure 5-11 on page 35</a>
1H	Narrow housing, 1 terminal field			
1H	Long connectors	AXL F DI16/1 HS 1H AXL F UTH4 1H AXL F RS UNI 1H		<a href="#">Figure 5-12 on page 36</a>
1H (S)	Short connectors	AXL SSI 1/AO 1		<a href="#">Figure 5-13 on page 36</a>
1H (UNI)	Universal	AXL F PWR 1H AXC F XT IB 1H		<a href="#">Figure 5-14 on page 36</a>
		AXL F DO16 FLK 1H		<a href="#">Figure 5-15 on page 37</a>

## 5.2 Basic design of Axioline F modules

### 5.2.1 Class 3000 AXC controller

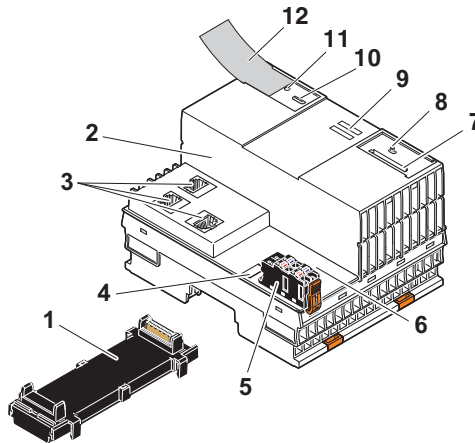

Figure 5-2 Design of an AXC 3050 controller

- 1 Bus base module
- 2 Electronics module
- 3 Ethernet interfaces
- 4 Function identification and FE tab:  
A 2.8 mm FE tab for optional functional ground connection is located under the function identification (see user manual for the controller)
- 5 Connector for connecting the communications power  $U_L$
- 6 USB interface
- 7 Slot for the parameterization memory
- 8 Mode selector switch
- 9 Diagnostic and status indicators (here: LEDs)
- 10 Programming interface
- 11 Reset button
- 12 Insert label

### 5.2.2 Class 2000 AXC F controller

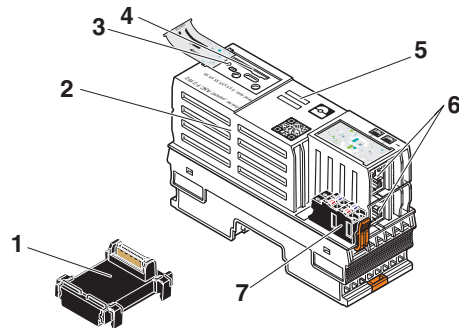

Figure 5-3 Design of an AXC F 2152 controller

- 1 Bus base module
- 2 Electronics module
- 3 Reset button
- 4 SD card holder (the SD card is optional and not supplied as standard)
- 5 Diagnostic and status indicators
- 6 Ethernet interfaces
- 7 Supply connector (connector for connecting the communications power  $U_L$ )

### 5.2.3 Bus coupler and class 1000 AXC controller

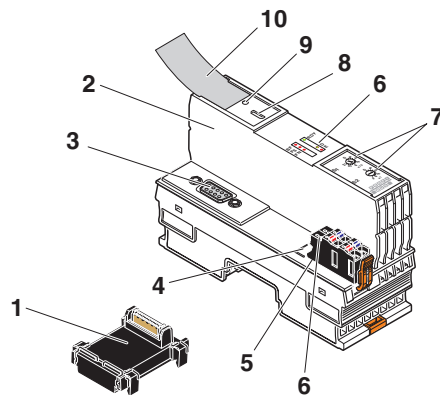

Figure 5-4 Design of a bus coupler

BK housing

Example: AXL F BK PB, AXC 1050

- 1 Bus base module
- 2 Electronics module
- 3 Bus connection (here: Ethernet connections, PROFIBUS connection)
- 4 Function identification
- 5 Connector for connecting the communications power  $U_L$
- 6 Diagnostic and status indicators (here: LEDs)
- 7 Rotary coding switch
- 8 Service interface
- 9 Reset button
- 10 Insert label



There are two FE springs on the bottom of the module for connecting the functional ground via the DIN rail. These are not shown in [Figure 5-4](#). They are illustrated in [Figure 9-1 on page 83](#).

### 5.2.4 I/O module (electronics module)

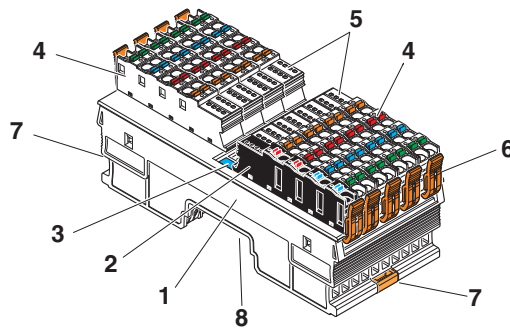

Figure 5-5 Design of an I/O module (example: AXL F DI16/4 2F)

- 1 Electronics module
- 2 Connector for connecting the I/O supply voltage ( $U_I$ ,  $U_O$ ,  $U_{IO}$  or  $U_A$ )
- 3 Function identification
- 4 Connectors for connecting the I/O
- 5 Diagnostic and status indicators
- 6 Locking latches of the I/O connectors
- 7 Base latch for latching to the DIN rail (2 x)
- 8 Device connector for connecting to the local bus via the bus base module (at the bottom, not illustrated)



There is at least one FE spring on the bottom of the module for connecting the functional ground via the DIN rail. This is not shown in [Figure 5-5](#). It is illustrated in [Figure 9-1 on page 83](#).

### 5.3 Axioline F module dimensions

All dimensions are in mm.

#### 5.3.1 AXC controller and bus coupler

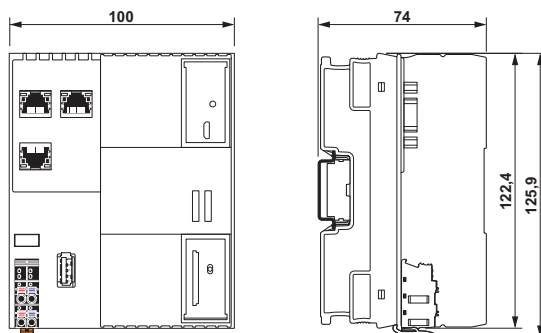

Figure 5-6 Nominal dimensions of a class 3000 AXC controller housing (type AXC 3, e.g., AXC 3050, AXC 3051)

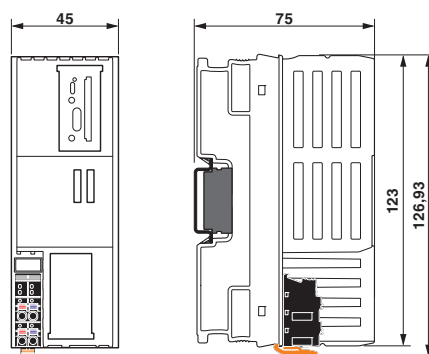

Figure 5-7 Nominal dimensions of a class 2000 AXC controller housing (type AXC F, e.g., AXC F 2152)

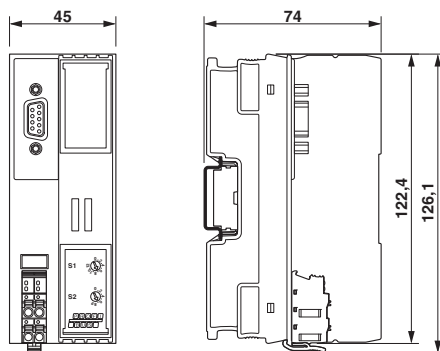

Figure 5-8 Nominal dimensions of a controller/bus coupler housing with separate bus base (type BK, e.g., AXL F BK PB, AXC 1050)

5.3.2 I/O modules for the 24 V area

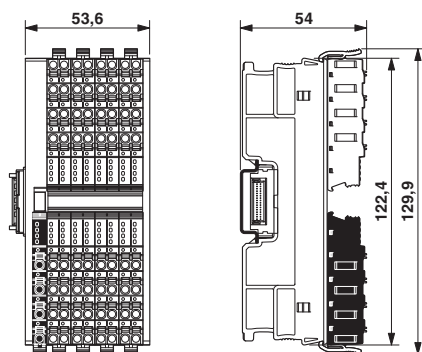

Figure 5-9 Nominal dimensions of the F housing with two terminal fields (type 2F, e.g., AXL F DI16/4 2F, AXL F DO16/3 2F)

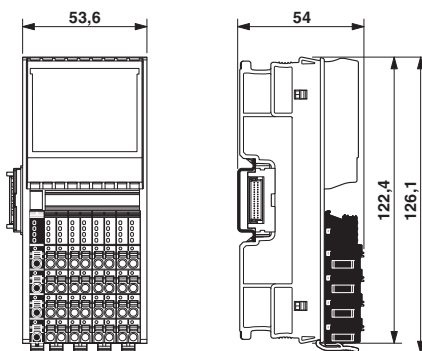

Figure 5-10 Nominal dimensions of the F housing with one terminal field (type 1F, e.g., AXL F AI8 XC 2H, AXL F DI32/1 2H)

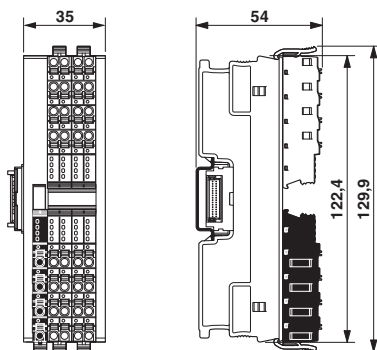

Figure 5-11 Nominal dimensions of the H housing with two terminal fields (type 2H, e.g., AXL F DI16/1 DO16/1 2H)

UM EN AXL F SYS INST

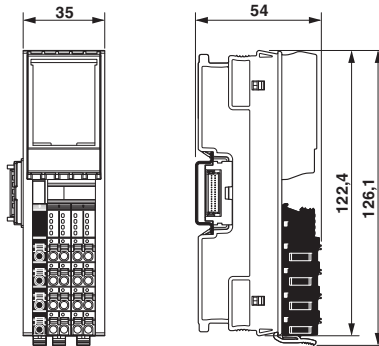

Figure 5-12 Nominal dimensions of the H housing with one terminal field (type 1H, e.g., AXL F DI16/1 HS 1H, AXL F UTH4 1H, AXL F RS UNI 1H)

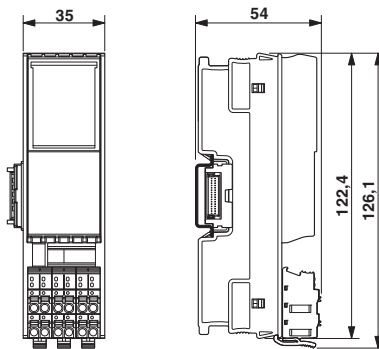

Figure 5-13 Nominal dimensions of the H housing with one terminal field and short connectors (type 1H (S), e.g., AXL F SSI1 AO1 1H)

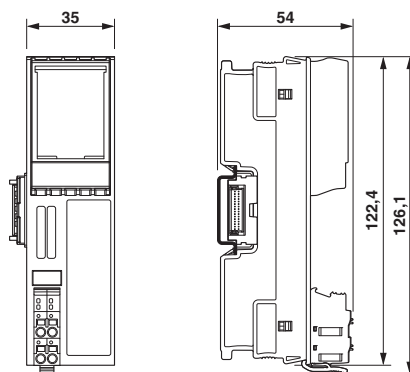

Figure 5-14 Nominal dimensions of the H housing with one terminal field and short connectors (type 1H (UNI), e.g., AXL F PWR 1H, AXC F XT IB 1H)

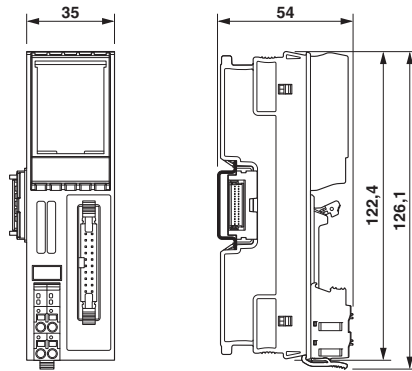

Figure 5-15 Nominal dimensions of the H housing with one terminal field and short connectors (type 1H (UNI), AXL F DO16 FLK 1H)

### 5.3.3 I/O modules for the low voltage area

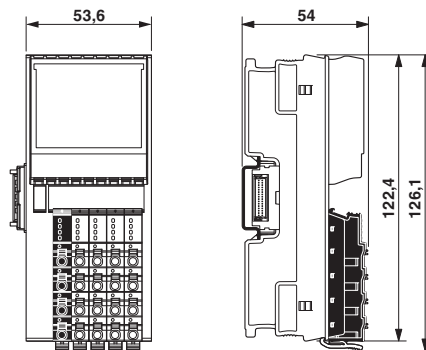

Figure 5-16 Nominal dimensions of the F housing for the low voltage area with one terminal field and five connectors (type 1F-LV5, e.g., AXL F DO4/3 AC 1F)

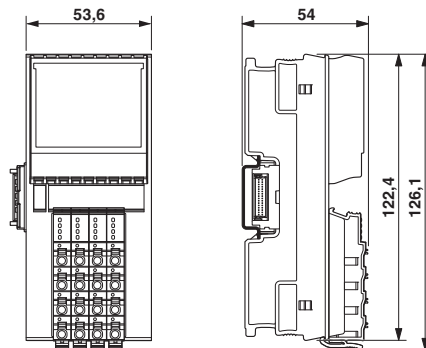

Figure 5-17 Nominal dimensions of the F housing for the low voltage area with one terminal field and four connectors (type 1F-LV4, e.g., AXL F DI8/2 110/220DC 1F, AXL F DOR4/2 AC/220DC 1F)

### 5.3.4 Power measurement module

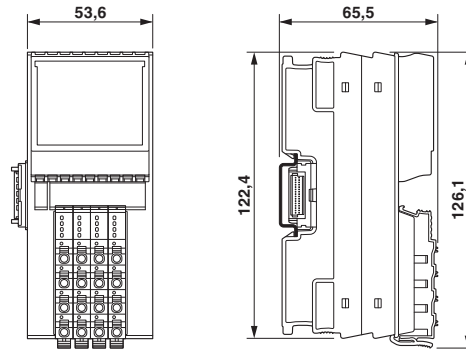

Figure 5-18 Nominal dimensions of the F housing for power measurement with one terminal field (type 1F-PM, AXL F PM EF 1F)

## 5.4 Bus base modules

Bus base modules connect the modules to each other.

Bus base modules carry the communications power and the bus signals from the bus coupler or the controller through the Axioline F station (local bus).

A bus base module is supplied as standard with each controller, bus coupler and Axioline F module.



### NOTE: Malfunction

Insert the bus base module belonging to the relevant module.

Bus base modules with different overall widths and functions are available (e.g., red bus base module for the power module).

### Versions

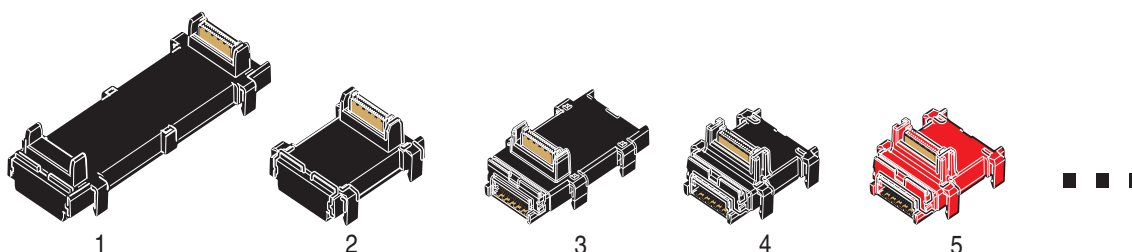

Figure 5-19 Bus base modules

Table 5-2 Bus base modules

No.	Type	Order No.	For use with
1	AXC BS	2701582	AXC 3xxx controller
2	AXL BS BK	2701422	Bus coupler in BK housing, AXC 1050 controller
3	AXL F BS F	2688129	F housing
4	AXL F BS H	2700992	H housing
5	AXL F BS H PWR	2702051	H housing, power module
...	Others		See device-specific documentation

### Basic design

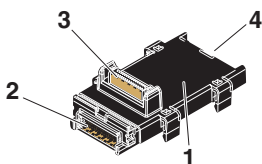

Figure 5-20 Design of a bus base module

- 1 Bus base module
- 2 Connection to the bus coupler or the previous bus base module (male connector)
- 3 Connection of the local bus to an I/O electronics module (female connector)
- 4 Connection for the following bus base module (female connector)

## 5.5 Axioline F connectors

The Axioline F connectors accept cables up to 1.5 mm<sup>2</sup> and a stripping length of 8 mm. Detailed information on the conductor cross sections and stripping lengths can be found in [Section “Conductor cross sections and stripping and insertion lengths” on page 63.](#)

### 5.5.1 Versions and dimensions

Various Axioline F connector versions are available.

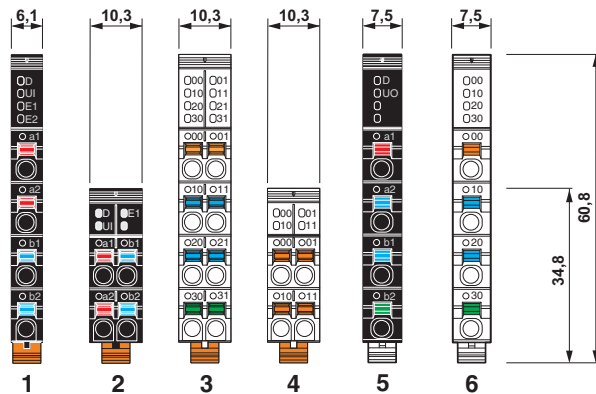

Figure 5-21 Connectors: versions and dimensions

Table 5-3 Connectors: versions and dimensions

No.	Color	Use	Examples of use
<b>24 V area</b>			
1	Black RAL 9005	Feeding the supply volt- ages	AXL F DI..., AXL F DO... AXL F AI..., AXL F AO... AXL F CNT2 INC2 1F
2			AXC 1xxx, AXC 3xxx AXL F BK ... AXL F SSI1 AO1 1H
3	Traffic gray A RAL 7042	I/O connection (protective extra-low volt- age)	AXL F DI..., AXL F DO... AXL F AI..., AXL F AO... AXL F CNT2 INC2 1F
	Zinc yellow RAL 1018	I/O connection (safety modules, protective extra-low voltage)	AXL F PSDI8/4 1F AXL F PSDO8/3 1F
4	Traffic gray A RAL 7042	I/O connection (protective extra-low volt- age)	AXL F SSI1 AO1 1H
<b>230 V area</b>			
5	Black RAL 9005	Feeding the supply volt- ages	AXL F DO4/3 AC 1F
6	Traffic gray A RAL 7042	I/O connection (low voltage)	AXL F DO4/3 AC 1F AXL F DOR4/2 AC/220 DC 1F

### 5.5.2 Basic design

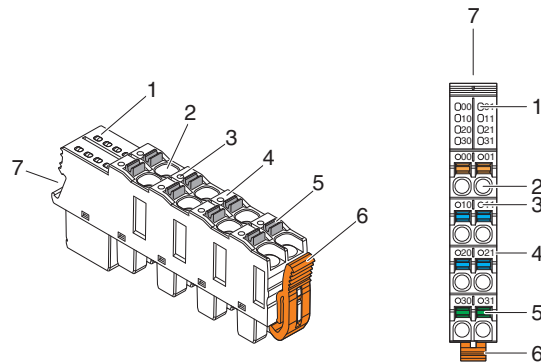

Figure 5-22 Basic design of an Axioline F connector

- 1 Local diagnostic and status indicators
- 2 Terminal point
- 3 Touch connection
- 4 Terminal point marking
- 5 Spring lever  
The color of the spring lever corresponds to the function (see [Section "Color and marking" on page 42](#))
- 6 Locking latch
- 7 Space for connector marking (zack marker strip ZBF 10/5,8 AXL or ZBF 5)

## 5.6 Color and marking

### Housing

The following housing colors are currently used for the electronics modules:

Table 5-4 Electronics module housing colors

Color	Similar RAL colors	Use
Traffic gray A	RAL 7042	Standard modules
Zinc yellow	RAL 1018	Safety modules

### Connectors

All the connectors for voltage supply are completely black (RAL 9005).

The bottom parts of the connectors for the I/O connection are black (RAL 9005).  
The upper parts match the color of the housing, i.e., traffic gray A or zinc yellow.

### Function identification

The module functions are color coded (1 in [Figure 5-23](#)).

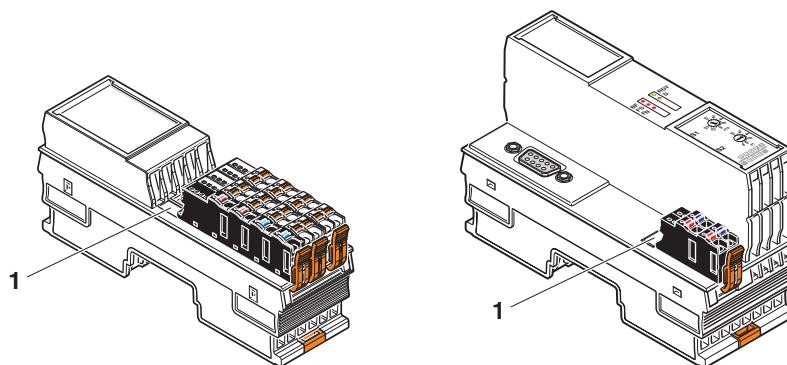

Figure 5-23 Color coding of the module function

The following colors indicate the function:

Table 5-5 Color coding of the module function

Color	Similar RAL color	Function of the module
Light blue	RAL 5012	Digital input
Flame red	RAL 3000	Digital output
Signal violet	RAL 4008	Digital input and output
Pale green	RAL 6021	Analog input, temperature measurement
Zinc yellow	RAL 1018	Analog output
Pastel orange	RAL 2003	Function: open and closed-loop control, communication, position detection
Pure white	RAL 9010	Bus coupler, controller, boost

Housing versions, design, and dimensions

- Connections**                      Apart from the Axioline F connectors, all connections are consecutively numbered, e.g., X1, X2 for Ethernet connections.
  
- Operating elements**            Operating elements are marked according to their function, e.g., rotary coding switches with S1 and S2 including the switch positions.
  
- Indication elements**            Diagnostic and status indicators are marked with the function, e.g., D, E, UI, 00, 01, ... (1 in [Figure 5-24](#)).
  
- Terminal points**                    The terminal points are consecutively numbered, e.g., a1, b1, 00, 01, ... (2 in [Figure 5-24](#)).  
 The associated colored spring lever indicates the function (signal, potential) (3 in [Figure 5-24](#)).

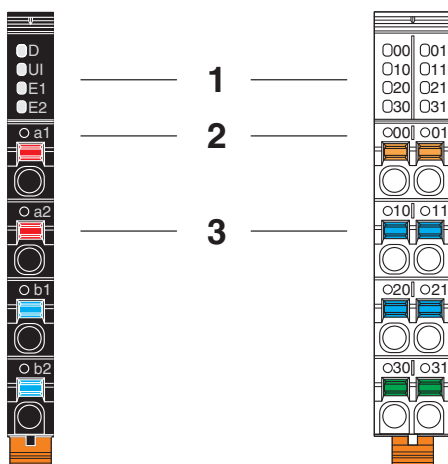

Figure 5-24 Marking of terminal points and LEDs on the connectors

Table 5-6 Color coding of the terminal point function

Color	Function of the terminal points	
	Low-level signal	Low voltage
Orange	Signal	Signal
Red	24 V DC	230 V AC, 220 V DC, relay main contact
Blue	GND	N (neutral conductor)
Green	FE (functional ground)	PE (protective conductor)



For the marking and function identification of a module, please refer to the module-specific data sheet.

## UM EN AXL F SYS INST

**Additional marking options**

In addition to the standard marking options detailed above, you can also custom-mark the module using a zack marker strip or an insert label.

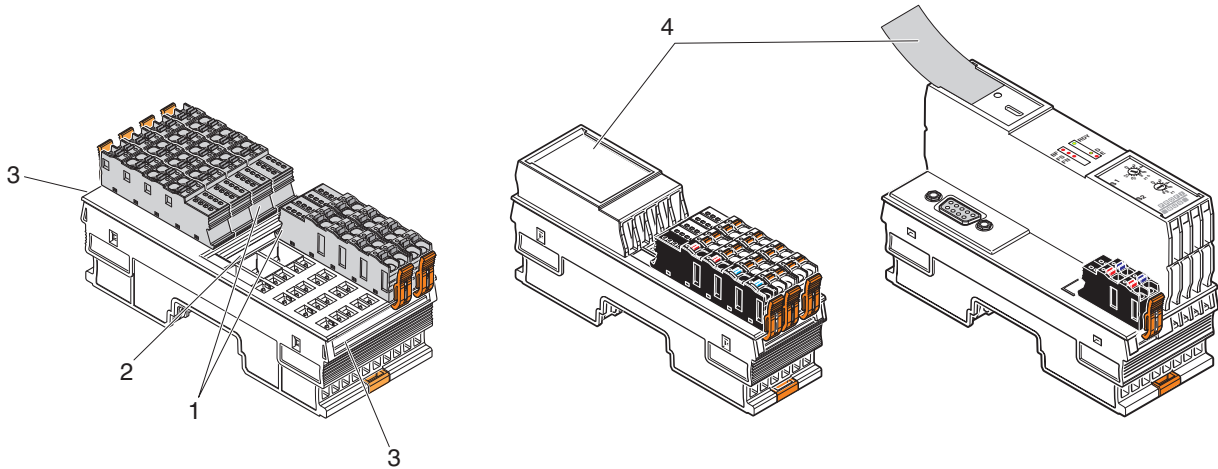

Figure 5-25 Individual marking options

- 1 Space for connector marking (zack marker strip ZBF 10/5,8 AXL or ZBF 5)
- 2 Space for module marking (zack marker strip ZB 20,3 AXL or ZB 10)
- 3 Space for slot marking (zack marker strip ZBF 10/5,8 AXL or ZBF 5)
- 4 Insert label (EMT (35X28)R, EMT (35X46)R, EMT (35X18,7)R)



Ordering data can be found in [Section "Ordering data" on page 130](#).

**Slot and connector marking**

Each slot on the module and the associated connector can be marked individually to ensure clear assignment between the slot and the connector (1 and 3 in [Figure 5-25](#)).

## 6 Transport, storage, and unpacking

### 6.1 Transport



**NOTE: Electrostatic discharge!**

Electrostatic discharge can damage or destroy components. When handling the device, observe the necessary safety precautions against electrostatic discharge (ESD) in accordance with EN 61340-5-1 and IEC 61340-5-1.

Axioline F modules are delivered packaged in a folded box.

- Please observe the notes on the packaging.
  - Only transport the device in its original packaging or in packaging suitable for transport.
  - During transport, observe the specifications regarding humidity and temperature range. See [Section “Technical data” on page 125](#).
- Suitable transport packaging**
- Technical data and environmental conditions**

### 6.2 Storage

- Suitable storage location**
- The storage location must meet the following requirements:
- Dry
  - Protected from external influences
  - Protected from harmful environmental influences such as UV light
- Technical data and environmental conditions**
- During storage, observe the specifications regarding temperature range, air pressure and humidity. See [Section “Technical data” on page 125](#).

### 6.3 Unpacking

- Observing the packing slip**
- Read the complete packing slip carefully before unpacking the device.
  - Retain the packing slip.
- Checking the delivery**
- Check delivery for damage and completeness.
  - Submit claims for any transport damage immediately.
- Scope of supply of standard modules**
- Axioline F module with inserted connectors
  - Associated bus base module
- Scope of supply of backplane**
- Axioline F backplane

## 7 Mounting and removing modules



If you use Axioline F backplanes (AXL F BP SE...), please observe [Section "Axioline F backplane" on page 97](#).

### 7.1 Safety notes for mounting and removal

#### 7.1.1 General safety notes



**NOTE: Electrostatic discharge**

The modules contain components that can be damaged or destroyed by electrostatic discharge. When handling the modules, observe the necessary safety precautions against electrostatic discharge (ESD) according to EN 61340-5-1 and IEC 61340-5-1.



**NOTE: Damage to electronics due to inadequate external protection**

**No safe fuse tripping in the event of an error**

Provide external fuses for the 24 V area of each module. If you use a fuse, the power supply unit must be capable of supplying four times the nominal current of the fuse. This ensures that the fuse trips reliably in the event of an error.

**NOTE: Disregarding this warning may result in damage of the contacts or malfunction**

Before working on a module, disconnect the module from the I/O devices and the power supply.

**For a bus coupler or controller, this means:**

- Disconnect the communications power supply  $U_L$  at the bus coupler or controller.

**For an I/O module, this means:**

- Disconnect the connected I/O devices from the power.
- Switch off the I/O supply voltage at the relevant module.

The communications power that is supplied at the bus coupler or controller is still available.

**For an Axioline F backplane, this means:**

- Disconnect the connected I/O devices of all inserted Axioline Smart Elements from the power.
- Switch off the I/O supply voltage  $U_P$ .
- Switch off the communications power supply  $U_L$  at the bus head of the station.

**For an Axioline Smart Element, this means:**

- Disconnect the connected I/O devices of the Axioline Smart Element from the power.
- Switch off the I/O supply voltage  $U_P$  at the backplane in which the Axioline Smart Element is located.
- Disconnect the communications power supply  $U_L$  at the bus coupler or controller.

**NOTE: Damage to the contacts when tilting**

Tilting the modules can damage the contacts.

- **Place the modules onto the DIN rail vertically.**
- **Remove the modules from the DIN rail vertically.**

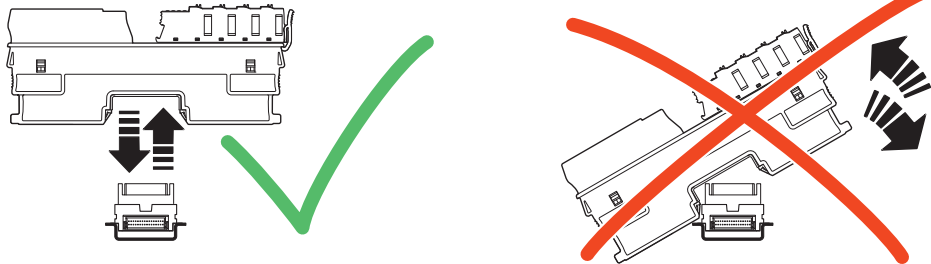

Figure 7-1 Placing and removing the module **vertically**



When using modules in the low voltage area, please also observe Section [“Additional safety notes for the low voltage area”](#) on page 49.

Additionally observe the information in the module-specific data sheets.

## 7.1.2 Additional safety notes for the low voltage area

### Installing the system

Install the system according to the requirements of EN 50178.

Only qualified personnel may work on Axioline F modules in the low voltage area.

In terms of this user manual, qualified personnel are persons who, because of their education, experience and instruction, and their knowledge of relevant standards, regulations, accident prevention, and service conditions, have been authorized to carry out any required operations, and who are able to recognize and avoid any possible dangers.

**WARNING: Dangerous contact voltage**

Please note that there are dangerous contact voltages when working on circuits that do not meet protective extra-low voltage requirements.

- The Axioline F modules for the low voltage area may only be mounted and removed when the power supply is disconnected.
- When working on the modules and wiring, always switch off the supply voltage and ensure it cannot be switched on again.
- The Axioline F modules for the low voltage area must only be operated in a closed control cabinet.

Failure to observe these instructions can lead to damage to health or even life-threatening injury.

**WARNING: Dangerous contact voltage in the event of ground faults**

- The Axioline F modules for the low voltage area must only be operated in grounded networks.



Additionally observe the information in the module-specific data sheets.

## 7.2 Basic information about mounting

### Mounting location

The Axioline F modules meet the requirements of IP20 degree of protection. They can therefore be used in closed control cabinets or in control boxes (junction boxes) with IP54 degree of protection according to EN 60529 or higher.

The compact design means that the Axioline F modules can be installed in standard junction boxes. Please observe the mounting distances when selecting the housing, see [Section "Mounting distances" on page 60](#).

### IP20 degree of protection

Insert the connectors onto the electronics modules in order to achieve IP20 degree of protection.

### DIN rail

All Axioline F modules are mounted on 35 mm standard DIN rails. The preferred height of the DIN rail is 7.5 mm (corresponds to TH 35-7.5 according to EN 60715).

The recommended DIN rails from Phoenix Contact or recommended mounting straps from Lütze can be found in [Section "Ordering data" on page 130](#).

Mount the modules **vertically** on the DIN rail. As the module does not need to be tilted it provides easy installation and removal, even in confined spaces.

The distance between DIN rail fasteners must not exceed 200 mm. This distance is necessary for the stability of the rail when mounting and removing modules.

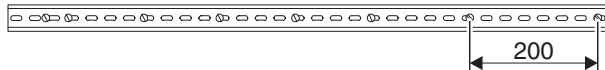

Figure 7-2 Fixing the DIN rail (in mm)



**NOTE: Damage to electronics from the fixing elements**

**Danger of malfunction**

If the fixing elements (screw, rivet, etc.) are too high, the bus base modules or the Axioline F backplane are not correctly snapped onto the DIN rail.

**For fixing the DIN rail, only use elements with a maximum installation height of 3 mm.**

**Mounting position**

Wall mounting on a horizontal DIN rail on the wall is the preferred mounting position (Figure 7-3, A). This mounting position provides optimum air flow for the modules.

Other mounting positions are possible, however, temperature derating may be required. Observe the ambient temperatures provided in the module-specific documentation.

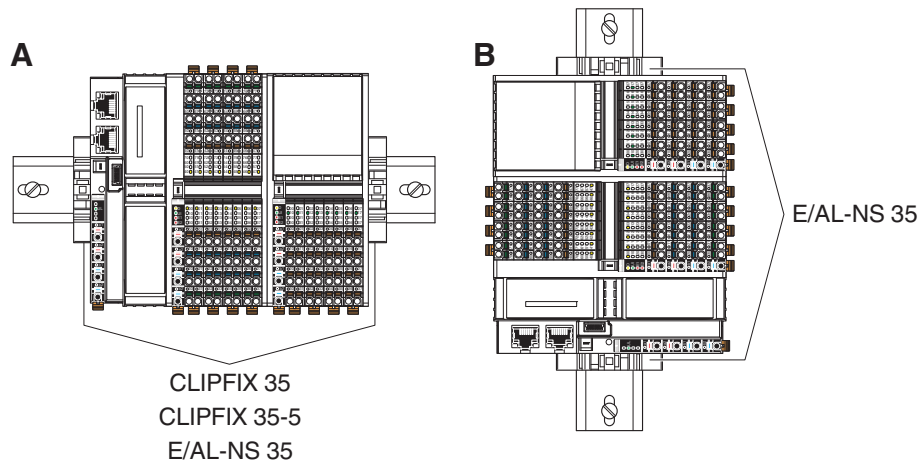

Figure 7-3 Mounting positions for an Axioline F station



The module-specific documentation specifies whether any other mounting position than the preferred mounting position is not permitted.

For Axioline F backplanes, only wall mounting on a horizontal or vertical DIN rail is permitted (as shown in Figure 7-3).

**End brackets**

Mount end brackets on both sides of the Axioline F station (see Figure 7-3). The end brackets ensure that the Axioline F station is correctly mounted on the DIN rail. They secure the station on both sides and keep it from moving from side to side on the DIN rail.

Always attach the left end bracket of the station when beginning to mount the station. This ensures the following:

- It prevents the station from slipping on the DIN rail.
- The space for the end bracket is secured.
- There is a counter pressure for the insertion force that occurs when the bus base modules are installed next to the bus coupler.

Table 7-1 Recommended end brackets

Mounting position	Ambient conditions	End bracket
Horizontal, Figure 7-3, A	Normal	CLIPFIX 35, CLIPFIX 35-5
	High shock and vibration load	E/AL-NS 35
Other, Figure 7-3, B	Normal	E/AL-NS 35
	High shock and vibration load	



If you use Axioline F backplanes in the station, use the CLIPFIX 35 or E/AL-NS 35 end brackets. See also Section "Ordering data" on page 130.

## UM EN AXL F SYS INST

---

<b>Tool</b>	<p>No tools are required for mounting the modules.</p> <p>A standard tool, e.g., a bladed screwdriver with a blade width of 2.5 mm, is necessary for removing the electronics modules and using the spring levers.</p>
<b>Order of the modules</b>	<p>The modules on the DIN rail can be installed in any order behind the bus coupler. To ensure functionality, mount the modules side by side, without a gap.</p> <p>If you are using modules with shield connection, installing them next to each other is recommended in order to make optimum use of the busbar for shield connection.</p>
<b>Maximum number of modules</b>	<p>The maximum number of Axioline F modules within a station is 63.</p> <p>The actual number of modules within an Axioline F station may be limited by the following factors:</p> <ul style="list-style-type: none"> <li>– Supplied logic current</li> <li>– Current consumption of the connected modules</li> <li>– System limits of the bus coupler</li> </ul>
<b>Power supply/ current consumption</b>	<p>The bus coupler, controller or the power module for the communications power provide the power supply for the local bus. In the module-specific documentation, this current value is specified as "Power supply at <math>U_{BUS}</math>".</p> <p>The total current consumption of all Axioline F modules arranged in the station must not exceed this maximum current. The logic current consumption values are specified for each module in the module-specific data sheet as "Current consumption from <math>U_{BUS}</math>".</p> <p>The following information is stored in the device description files (e.g., gsdml file):</p> <ul style="list-style-type: none"> <li>– Current supplied by the bus coupler, controller or power module</li> <li>– Maximum current consumption of the modules that can be connected</li> </ul> <p>You can use these maximum currents in the engineering tool for configuration in order to prevent an overload of the communications power.</p>



**NOTE: Electronics may be damaged when overloaded**

Observe the current consumption of each device when configuring an Axioline F station. It is specified in every module-specific data sheet and may vary. As such, the permissible number of devices that can be connected therefore depends on the station structure.

Install a power module for the communications power if the maximum current consumption at  $U_{BUS}$  is reached. Create another station as an alternative.

**System limits of the bus coupler**

For information regarding the system limits of the bus coupler or controller used, please refer to the module-specific documentation. The system limits include:

Table 7-2 System limit examples

Network	Bus coupler	System limits
Sercos	AXL F BK S3	Amount of process data
PROFINET	AXL F BK PN	Amount of process data
PROFIBUS	AXL F BK PB	Amount of process data
		Amount of parameter data
		Amount of configuration data

The amount of process data and the amount of parameter and configuration data for PROFIBUS are documented in the module-specific data sheet for each I/O module.

If the system limits of the bus coupler or controller are reached, create a new station.

**Example structure of an Axioline F station**

See [Section “Example of an Axioline F station” on page 14.](#)

## 7.3 Left alignment

The following sections describe mounting and removal of standard modules. Observe the information in the “Installation notes for electricians” for modules that are installed to the left of the controller. They are provided with the product upon delivery.

## 7.4 Mounting the modules



Please refer to [Section “Safety notes for mounting and removal” on page 46.](#)

No tools are required for mounting the Axioline F modules.

- First mount the end bracket on the DIN rail.

### 7.4.1 Bus base modules, controllers, and bus couplers

#### Mounting the bus base modules



- First install the bus base module for the controller or bus coupler onto the DIN rail.
- Place all other bus base modules required for the station on the DIN rail (Figure 7-4, A).

**NOTE: Malfunction**

Insert the bus base module belonging to the relevant module.  
Bus base modules with different overall widths and functions are available.

- Push each subsequent bus base module into the connection of the previous bus base module (Figure 7-4, B).

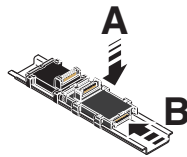

Figure 7-4 Connecting bus base modules to each other



It is not possible to snap another bus base module to the previous bus base module if there is already an electronics module on it. In this case, first remove the last electronics module before snapping on more bus base modules.

#### Snapping on the controller or bus coupler

- Place the controller or bus coupler **vertically** on the first bus base module and the DIN rail until it snaps into place with a click.  
Make sure that the device connector for the bus base connection is positioned above the corresponding female connector on the bus base module.

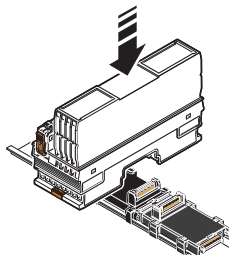

Figure 7-5 Snapping on the bus coupler

#### Connecting the network

Connect the network according to the specifications in the module-specific documentation.

### 7.4.2 I/O modules

- Place the necessary I/O modules **vertically** on the corresponding bus base modules and DIN rail until they snap into place with a click. Pay attention to the correct position. Make sure that the device connectors for the bus base connection are positioned above the corresponding female connectors on the bus base module.

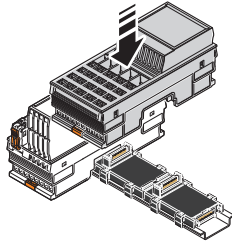

Figure 7-6 Inserting I/O modules

If you are using analog modules, mount the necessary shield connection elements.



For connecting the shield, Phoenix Contact recommends the AXL SHIELD SET Axioline F shield connection set or the shield connection clamp products from the “Installation and mounting material, grounding, and shielding” product range.

When using the AXL SHIELD SET, mount the elements in the following order:

1. Bus base module
2. Shield bus holder
3. Electronics module

See [Section “Connecting the shield using the Axioline F shield connection set” on page 85](#).

## 7.5 Removing modules



Please refer to Section [“Safety notes for mounting and removal”](#) on page 46.

A standard tool, e.g., a bladed screwdriver with a blade width of 2.5 mm is necessary for removing modules.

### 7.5.1 Removing connectors or cables

#### Removing the network connector

- Remove the network connector, if present, according to the specifications in the module-specific documentation.

#### Supply connector, I/O connector

- Prior to module removal, also remove the connectors or cables, if present, from the module.
  - If no cables are inserted, the connectors do not need to be removed.
  - If cables are inserted, either remove the connectors from the module or the cables from the connectors.
 

The cables should only be removed from the connector if you wish to change the wiring or no longer wish to use the connector.

#### Removing cables

See [Section “Removing cables from the terminal point”](#) on page 68.

#### Removing the Axioline F connectors

See [Section “Removing or inserting a connector”](#) on page 59.

### 7.5.2 Controller, bus coupler, and I/O modules

The controller, bus coupler and each I/O module can be removed individually from the station.

- Insert a suitable tool (e.g., bladed screwdriver) in the upper **and** lower snap-in mechanism (base latches) of the module one after the other and unlock it (Figure 7-7, Figure 7-8, A). The base latches are locked in place in the open position.
- Remove the electronics module **vertically** to the DIN rail (Figure 7-7, Figure 7-8, B). The base latches return to the idle position again.

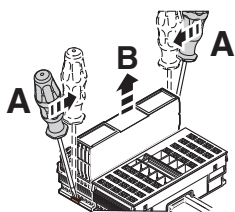

Figure 7-7 Removing the bus coupler

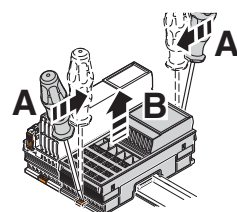

Figure 7-8 Removing an I/O module

The bus base module remains on the DIN rail.

#### Bus base module

Please proceed as follows if, after having removed modules, you want to remove bus base modules from the DIN rail as well:

- If a module is located on the neighboring bus base module to the left, remove it.

If the bus base module is in the end position:

- Remove the bus base module from the connection of the previous bus base module by sliding it approximately 5 mm to the right (A).
- Insert a suitable tool (e.g., bladed screwdriver) into the latches on one side (B, B1, B2) one after the other.
- Swivel the bus base module upward and remove it (C).

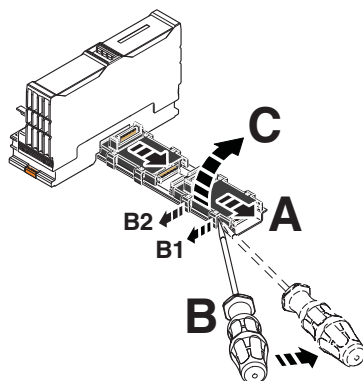

Figure 7-9 Removing the bus base module

## UM EN AXL F SYS INST

---

If the bus base module to be removed is inside the station:

- If possible, push the following bus base modules and any fitted modules approximately 15 mm to the right.  
In doing so, disconnect the bus base module you want to remove from the connection of the following bus base module.
- If it is not possible to slide the following bus base modules and modules, remove the modules. Starting at the end of the station, remove the bus base modules.
- Disconnect the bus base module to be removed from the connection of the previous bus base module by sliding it about 5 mm to the right (A).
- Insert a suitable tool (e.g., bladed screwdriver) into the latches on one side (B, B1, B2) one after the other.
- Swivel the bus base module upward and remove it (C).
- Push the rest of the station back to the left until the bus base modules touch each other again.

## 7.6 Removing or inserting a connector

### 7.6.1 Removing a connector

- Release the locking latch (A). Tilt the connector slightly upward (B). Remove the connector from the module (C).

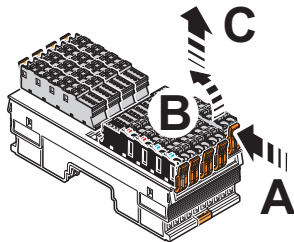

Figure 7-10 Removing the connector

### 7.6.2 Inserting a connector

- Insert the connector vertically into its position. Press firmly on the connector. Make sure that it engages with a click.

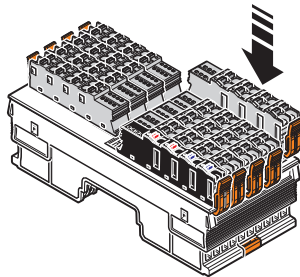

Figure 7-11 Snapping on the connector

## 7.7 Replacing a module

- To replace a module, proceed as described in Sections [“Removing modules” on page 56](#) and [“Mounting the modules” on page 53](#).
- Once replaced, restore all the necessary connections.

**When replacing a controller:**

Observe any notes for replacement in the module-specific documentation.

## 7.8 Mounting distances

The space required for cable routing depends on the number of cables to be installed. Leave this space free at the bottom and/or at the top.

For the distances of the upper and lower cable ducts or the cable routing to the modules, please refer to [Figure 7-13](#) to [Figure 7-14](#).



In addition to the specified dimensions, provide adequate space for mounting and removal of the connectors and cables.

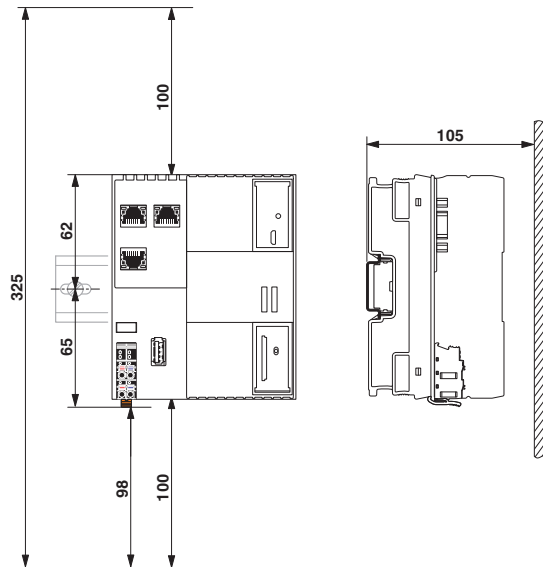

Figure 7-12 Mounting distances: AXC 305x, AXC F 2151 controller (dimensions rounded)

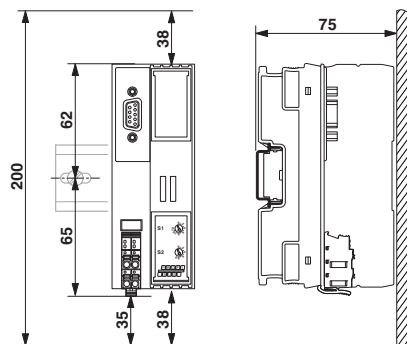

Figure 7-13 Mounting distances: bus coupler and AXC 105x controller (dimensions rounded)

Mounting and removing modules

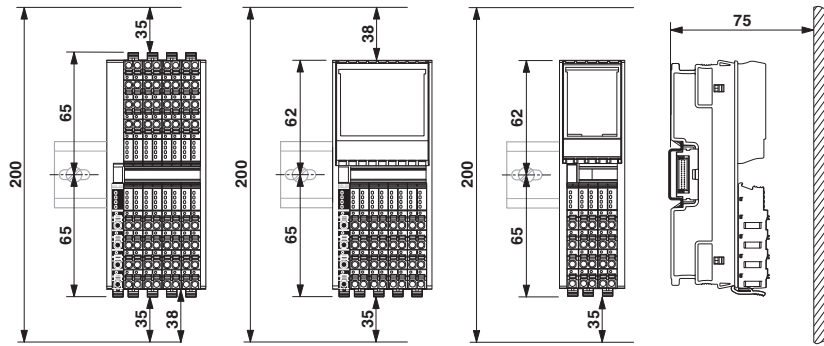

Figure 7-14 Mounting distances: I/O modules (dimensions rounded)

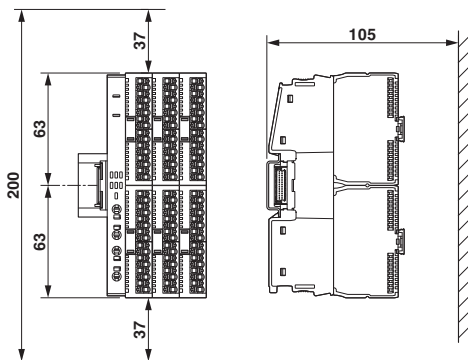

Figure 7-15 Mounting distances: AXL F BP SE ... with inserted Axiline Smart Elements



If the distances are smaller, the minimum bending radius of the cables, easy handling during installation, and a clear structure cannot be assured.

## 8 Connecting or removing cables



If you use Axioline F backplanes (AXL F BP SE4 or AXL F BP SE6), please observe [Section “Axioline F backplane” on page 97](#).

### 8.1 Connections and cables in the Axioline F system

All electrical connections are pluggable.

The network cables on the controller or bus coupler are connected via the D-SUB or RJ45 connectors depending on the network.

The cables for the I/O devices and supply voltages are connected using Axioline F connectors.

Each terminal point is designed for a maximum current of 8 A. This applies to the periphery of the I/O modules (I/O connectors) as well as to the supply of the logic, sensors, and actuators (power connectors).



The current can be reduced when used in applications in which an UL approval is required. Observe any specifications in the module-specific packing slip and the rating on the modules.

When using Axioline F modules you can use shielded and unshielded, solid and stranded cables, with or without ferrules.

Please observe the following when wiring:

- Make sure to install the conductor in the middle of the wiring space, especially with small cross sections.



If you are using ferrules, comply with the specifications described in [Section “Conductor cross sections and stripping and insertion lengths” on page 63](#).

Make sure that the ferrules are crimped correctly.

## 8.2 Conductor cross sections and stripping and insertion lengths



If you use Axioline F backplanes (AXL F BP SE4 or AXL F BP SE6), please observe [Section "Axioline F backplane" on page 97](#).



For electrical and/or thermal reasons, it may not be possible to use the minimum conductor cross sections specified here for certain modules.

Therefore, always observe the information in the module-specific documentation.

### Conductor cross sections

Table 8-1 Permissible conductor cross sections for Push-in connection technology (tool-free conductor insertion)

Conductor	Cross section
Solid	0.5 mm <sup>2</sup> .... 1.5 mm <sup>2</sup>
Stranded with ferrule without insulating collar (A ...)	
– According to DIN 46228-1 sleeve length 10 mm	0.25 mm <sup>2</sup> .... 1.5 mm <sup>2</sup>
Stranded with ferrule with insulating collar (AI ...)	
– According to DIN 46228-4 sleeve length 8 mm	0.25 mm <sup>2</sup> .... 1.0 mm <sup>2</sup>
– According to DIN 46228-1 sleeve length 10 mm	0.25 mm <sup>2</sup> .... 1.5 mm <sup>2</sup>



Stranded cables without ferrules are only suitable for Push-in connection technology **when using the spring lever**.

Table 8-2 Permissible conductor cross sections **when using the spring lever** for inserting the conductor

Conductor	Cross section
Solid	0.2 mm <sup>2</sup> .... 1.5 mm <sup>2</sup>
Stranded without ferrule	0.2 mm <sup>2</sup> .... 1.5 mm <sup>2</sup>
Stranded with ferrule without insulating collar (A ...)	0.25 mm <sup>2</sup> .... 1.5 mm <sup>2</sup>
Stranded with ferrule with insulating collar (AI ...)	0.25 mm <sup>2</sup> .... 1.5 mm <sup>2</sup>

Table 8-3 Permitted AWG conductor cross sections

Conductor	Cross section
AWG	24 ... 16

## UM EN AXL F SYS INST

---

### Stripping and insertion lengths

**NOTE: Malfunction when the conductor is not securely fixed**

To ensure secure fixing and correct function:

Make sure that the stripping length of a conductor without ferrule or the insertion length of a conductor with ferrule corresponds to the specifications.

For crimping, we recommend pliers for trapezoidal crimp: CRIMPFOX 6 or CRIMPFOX 6T(-F), see [Section "Ordering data for accessories" on page 130](#).

According to the current state, these crimping pliers meet the general conditions regarding the Axioline F wiring space (according to internal cylindrical gauge DIN EN 60947-1 (DIN VDE 0660-100)-A1).

Conductor without ferrule: stripping length 8 mm

Conductor with ferrule: insertion length 8 mm or 10 mm

Ferrules: see [Section "Ordering data" on page 130](#).

### TWIN ferrules

**NOTE: Malfunction when using wrong ferrule**

**TWIN ferrules are not permitted in the Axioline F system.**

### 8.3 Terminal point, associated spring lever, and associated touch connection

When using the screwdriver, pay attention to the position of the spring lever to the assigned terminal point.

When testing the signal with a measuring probe, pay attention to the position of the touch connection to the assigned terminal point.

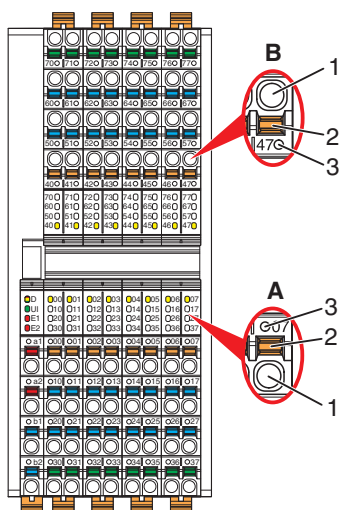

Figure 8-1 Terminal point with associated spring lever, and associated touch connection

- A Cable outlet at the bottom: Spring lever and touch connection **above** the terminal point
- B Cable outlet at the top: Spring lever and touch connection **below** the terminal point (B)
- 1 Terminal point
- 2 Spring lever
- 3 Touch connection

## 8.4 Connecting unshielded cables

Wire the connectors according to your application.



For the terminal point assignment, please refer to the corresponding module-specific documentation.

When wiring, proceed as follows:

- Strip 8 mm off the cable.

### Without tools (Push-in)

Suitable for:

- Conductor cross section from 0.5 mm<sup>2</sup> onwards
- Solid cables
- Stranded cables with ferrules

- Insert the cable into the terminal point. It is clamped into place automatically.

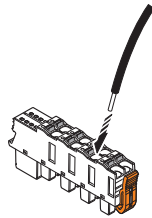

Figure 8-2 Connecting a solid unshielded cable

### With tools

Suitable for:

- Stranded cables
- Solid cables
- Stranded cables with ferrules

- Open the spring by pressing the screwdriver onto the spring lever (Figure 8-3, A). Use, for example, a bladed screwdriver with a blade width of 2.5 mm. Phoenix Contact recommends the SZS 0,4x2,5 screwdriver (see Section “Ordering data” on page 130).
- Insert the cable in the terminal point (B).
- Remove the screwdriver to secure the cable.

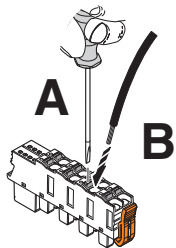

Figure 8-3 Connecting a stranded cable

**Inserting the connector**

- Insert the connector vertically into its position. Press firmly on the connector. Make sure that the locking latch snaps into place.

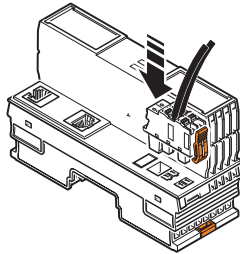

Figure 8-4 Inserting the connector

**8.5 Connecting shielded cables**

Please also observe the information in [Section “Shielding concept” on page 84](#) for shielding.

Connect the shield before the module.

When connecting the cables, proceed as follows:

**Stripping the cables, connecting the shield**

- Strip approximately 20 mm off the outer sheath of the cable at the required distance from the end of the cable (a in [Figure 8-5](#)).  
The necessary distance a depends on the distance to the busbar.
- Strip 8 mm off the wires.

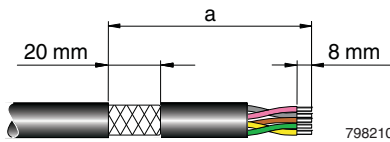

Figure 8-5 Connecting the shielded cable

- If present, remove the protective foil.
- Lay the cable with the braided shield under a shield connection clamp. Tighten it using a screw.

Malfunctions will then be led to the support brackets via a busbar. The support brackets are connected to the grounded DIN rail.

Ordering data can be found in [Section “Ordering data” on page 130](#).



Make sure the shield is as close as possible to the signal terminal points.

When using twisted pair cables, keep the cable twisted until just before the terminal point.

**NOTE:**

The busbar is only for shielding the module, not for the strain relief of the connected cables.

**Wiring the connector**

- Connect the cables to the connector. Please proceed as described in [Section “Connecting unshielded cables” on page 66](#).

## 8.6 Removing cables from the terminal point

- To remove a cable from the terminal point, press on the spring lever using a suitable tool (e.g., bladed screwdriver with a blade width of 2.5 mm). This opens the leg-spring connection of the relevant terminal point (Figure 8-6, A).
- Remove the conductor (Figure 8-6, B).

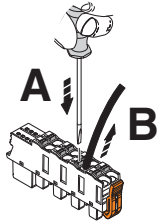

Figure 8-6 Removing the cable

## 8.7 Connecting the power supplies

### 8.7.1 Axioline F system supply

When using an Axioline F station, you must provide the following supply voltages:

- Supply voltage for the bus coupler or controller ( $U_L$ )
- Supply voltage for sensors and actuators

Unshielded cables are usually sufficient for connecting the power supplies. Connect them as shown in [Section "Connecting unshielded cables" on page 66](#).



For the connector pin assignment of the supply voltage connections, please refer to the module-specific documentation.

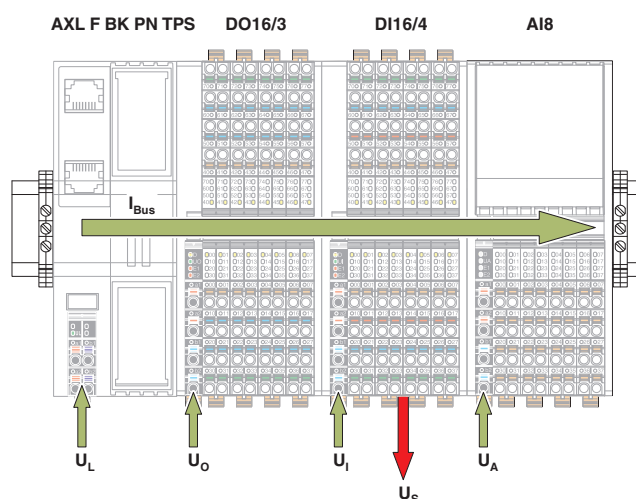

Figure 8-7 Supply voltages in the Axioline F system

Key:

$U_L$	( $U_{Logic}$ )	Communications power supply
$U_{Bus}$	( $U_{Bus}$ )	Power supply of the Axioline F local bus (generated from $U_L$ )
$U_I$	( $U_{Input}$ )	Supply for digital input modules Sensor/encoder supply (AXL F CNT2 INC2 1F) Encoder/analog supply (AXL F SSI1 AO1 1H)
$U_S$	( $U_{Sensor}$ )	Sensor supply (generated from $U_I$ )
$U_O$	( $U_{Output}$ )	Supply for digital output modules
$U_{IO}$	( $U_{Input/Output}$ )	Supply for digital input and output modules (I/O modules)
$U_A$	( $U_{Analog}$ )	Supply for analog modules
$I_{Bus}$	( $I_{Bus}$ )	Power supply for the local bus



For information regarding which supply voltage is used with a module, please refer to the module-specific documentation.

## 8.7.2 Power supply requirements

Choose a power supply unit that is suitable for the currents in your application. The selection depends on the bus configuration and the resulting maximum currents.



**WARNING: Loss of electrical safety when using unsuitable power supplies. Dangerous shock currents.**

The Axioline F low-level signal controllers, bus couplers, and modules are designed exclusively for protective extra-low voltage (PELV) operation according to EN 60204-1. Only PELV according to the defined standard may be used for supply purposes.

- Only use power supply units that ensure safe isolation according to EN 50178 and EN 61010-2-201. They prevent short circuits between the primary and secondary circuit.



**WARNING: Dangerous contact voltage in the event of ground faults**

- The Axioline F modules for the low voltage area must only be operated in grounded networks.



Die IEC 61131-2 requires power failure protection of 10 ms. To meet this requirement, use only power supply units (230 V AC / 24 V DC, 400 V AC / 24 V DC) that support mains buffering for at least 10 ms.



Observe the information in the module-specific documentation.

## 8.7.3 Supply at the controller or bus coupler

Communications power ( $U_L$ ) is supplied at the controller or bus coupler. It supplies the module electronics (logic) of the controller or bus coupler. Additionally, it generates the communications power for the local bus ( $U_{BUS}$ ), which supplies the connected modules with logic current.

If the communications power  $U_L$  is disconnected, the local bus will shut down.

## 8.7.4 Supply at the power module

If the maximum load of the bus coupler for the Axioline F local bus supply (communications power  $U_{BUS}$ ) is reached, you can use a power module to provide this voltage again.

To this end, apply a 24 V DC voltage ( $U_L$ ) to the module from which  $U_{BUS}$  is generated.



**NOTE: Malfunction**

The power module only boosts the  $U_{BUS}$  voltage when it is snapped onto the associated red bus base module and when the  $U_{BUS}$  voltage is available in the bus segment upstream of the power module.

### 8.7.5 Supply at the I/O modules

The inputs and outputs, as well as the sensors, are supplied directly at each module.

The input and output power supply ( $U_I/U_O/U_{IO}/U_A$ ) should be installed and fused independently of the communications power ( $U_L$ ). In this way, the local bus can be operated even if some I/O devices are switched off. This also prevents unnecessary interference couplings between I/O and logic.

The use of separate power supply units for  $U_L$  and  $U_I/U_O/U_{IO}/U_A$  may be necessary in environments with a lot of interference.

### 8.7.6 Jumpers in power connectors, potential forwarding, and fusing

Terminal points a1 and a2, as well as b1 and b2 are jumpered in the power connector. You can therefore use one of the terminal points for supply and the second terminal point for forwarding a potential.



**NOTE: Module damage when overloaded**

Please note that the maximum current carrying capacity of a terminal point of 8 A must not be exceeded.

Protect the supply accordingly.

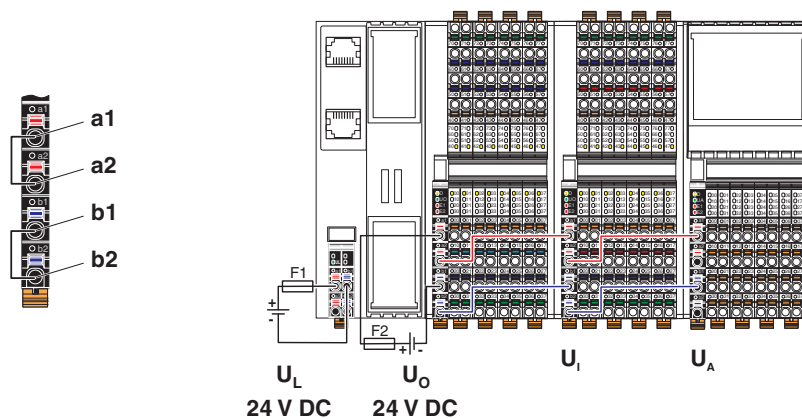

Figure 8-8 Jumpering in the power connector and example of potential forwarding

F1, F2 Protecting the supply voltage using suitable fuses (see module-specific documentation)



Considering the current carrying capacity of the terminal points, potential forwarding as shown in Figure 8-8 must not be used when the digital output module is fully loaded (e.g., AXL F DO16/3 2F current consumption at  $U_O$  is 8 A, maximum).

### 8.7.7 Parallel supply

If the maximum current consumption is greater than 8 A for a module, however, you wish to fully load the module, the supply voltage can be supplied in parallel. The module can now be loaded with 16 A, maximum.

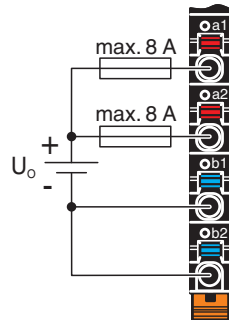

Figure 8-9 Parallel supply of the supply voltage

## 8.8 Connecting the network

Your network cable is connected to a controller or bus coupler.



Connect the network according to the module-specific documentation.

## 8.9 Connecting the USB cable to the USB interface

The AXC 305x controllers are provided with a programming interface, and the AXC 105x controllers and the bus couplers are provided with a service interface. For the type of the USB socket, please refer to the module-specific data sheet. In addition to providing the network interface, the interface enables communication with the controller or bus coupler from a PC.

This interface can be used, for example, to assign the IP address of the controller or bus coupler. In addition, the Diag+ diagnostic tool can be used to access the controllers, and Startup+ can be used to access the bus couplers and the class 1000 controllers.



To use the programming interface, a corresponding driver must be installed. It is provided with the software tools from Phoenix Contact.

A connecting cable is required for direct connection of the controller or bus coupler to a PC via the programming or service interface.

Table 8-4 Connection cable

Interface type	Type	Order No.
Micro USB	CAB-USB A/MICRO USB B/2,0M	2701626
USB type C	CAB-USB A/ USB C/1,8M	2404677



Do not connect the USB connecting cable until you have supplied the controller or bus coupler with voltage and the controller or bus coupler has successfully entered the operating state following startup.

- Connect the connecting cable to the programming or service interface of the controller or bus coupler and to a free USB interface of the PC.

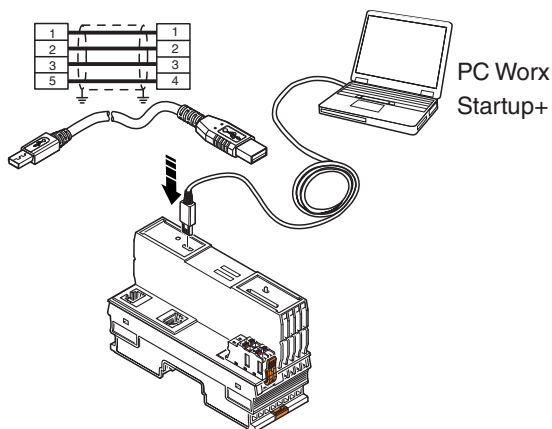

Figure 8-10 Connecting cable between PC and controller or bus coupler

## 8.10 Connecting sensors and actuators

Sensors and actuators are connected using I/O module connectors.

Connect the unshielded cables as described in [Section “Connecting unshielded cables” on page 66](#).

Connect the shielded cables as described in [Section “Connecting shielded cables” on page 67](#).

### 8.10.1 Connection technology for sensors and actuators

The I/O modules of the Axioline F product group normally permit connection of sensors and actuators in 1, 2, 3 or 4-wire technology.

The relevant module-specific data sheets indicate which connection technology is possible for the individual modules.

### 8.10.2 Connections used for low-level signal digital I/O modules



For the actual terminal point assignment, please refer to the corresponding module-specific data sheet. It also provides a connection example.

Table 8-5 Overview of the connections used for low-level signal digital input modules

Connection	Representation in the figure	1-wire	2-wire	3-wire	4-wire
Sensor signal IN	IN	X	X	X	X
Sensor supply $U_S$	$U_S (+24 V)$	-	X	X	X
Ground GND	GND	-	-	X	X
Grounding/FE shielding	FE ( $\perp$ )	-	-	-	X

X Used  
- Not used

Table 8-6 Overview of the connections used for low-level signal digital output modules

Connection	Representation in the figure	1-wire	2-wire	3-wire
Actuator signal OUT	OUT	X	X	X
Actuator supply $U_O$	$U_O (+24 V)$	-	-	-
Ground GND	GND	-	X	X
Grounding/FE shielding	FE ( $\perp$ )	-	-	X

X Used  
- Not used

### 8.10.3 Connecting digital sensors and actuators using different connection technologies

#### 1-wire technology

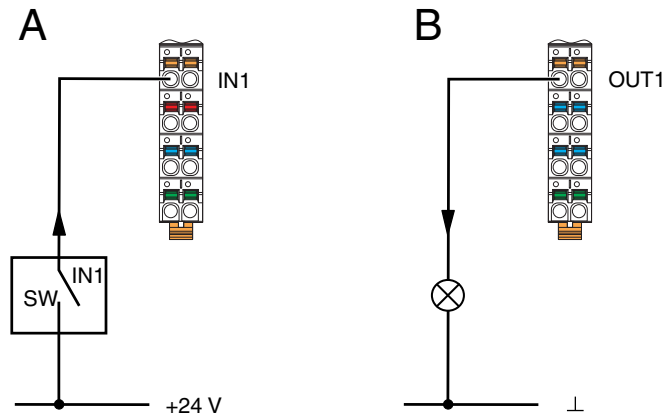

Figure 8-11 1-wire connection for digital modules

#### Sensor

Figure 8-11, A, shows the connection of a 1-wire sensor.

- The switch SW provides the input signal.
- The sensor signal is routed to terminal point IN1.
- The sensor is supplied with a 24 V voltage.



**NOTE: Malfunction**

To ensure the correct function, supply the sensors and  $U_1$  from a power supply with a common GND as reference potential.

#### Actuator

Figure 8-11, B, shows the connection of a 1-wire actuator.

- The actuator is supplied by output OUT1.
- The load is switched directly via the output.



**NOTE: Malfunction**

To ensure the correct function, make sure that GND of the actuators and GND of the supply voltage  $U_o$ , which supplies the actuators, have the same potential.

## 2-wire technology

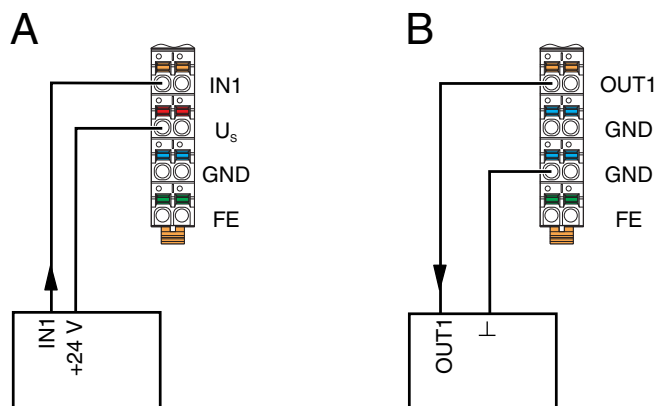

Figure 8-12 2-wire connection for digital modules

## Sensor

Figure 8-12, A, shows the connection of a 2-wire sensor.

- The sensor signal is routed to terminal point IN1.
- The sensor is supplied by voltage  $U_s$ .

## Actuator

Figure 8-12, B, shows the connection of an actuator.

- The actuator is supplied by output OUT1.
- The load is switched directly via the output.

## 3-wire technology

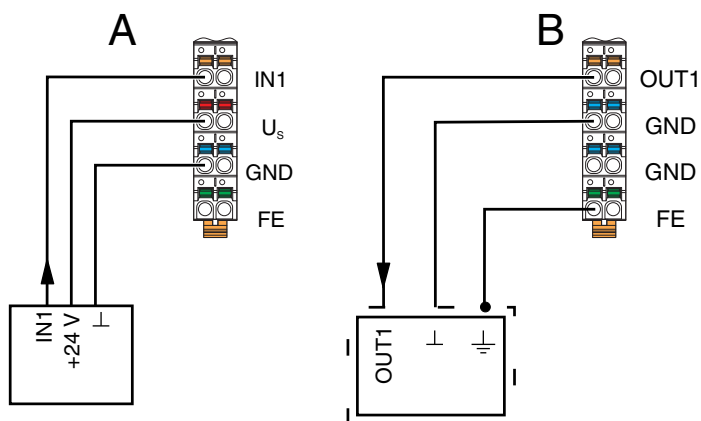

Figure 8-13 3-wire connection for digital modules

## Sensor

Figure 8-13, A, shows the connection of a 3-wire sensor.

- The sensor signal is routed to terminal point IN1.
- The sensor is supplied with power via terminal points  $U_s$  and GND.

## Actuator

Figure 8-13, B, shows the connection of a shielded actuator.

- The actuator is supplied by output OUT1.
- The load is switched directly via the output.
- The actuator is grounded via the terminal point FE.

## UM EN AXL F SYS INST

---

### 4-wire technology

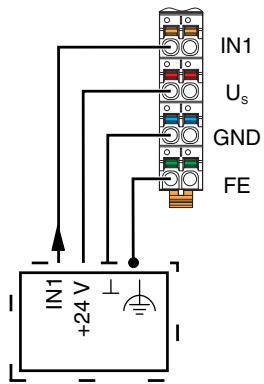

Figure 8-14 4-wire connection for digital modules

### Sensor

Figure 8-14 shows the connection of a shielded 4-wire sensor.

- The sensor signal is routed to terminal point IN1.
- The sensor is supplied with power via terminal points U<sub>S</sub> and GND.
- The sensor is grounded via the terminal point FE.

### 8.10.4 FLK

You can connect PLC relays from the “Interface” product range quickly and conveniently using the AXL F DO16 FLK 1H digital output module with 20-pos. FLK connection. This means that you can also use this output module in applications which require relays, e.g., to switch high voltages or currents.

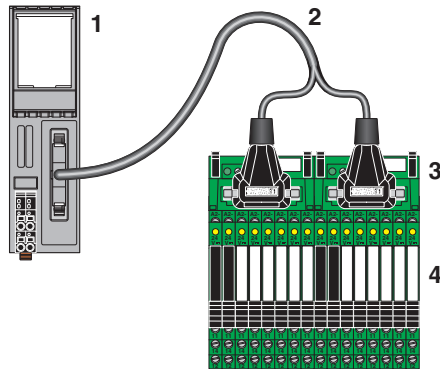

Figure 8-15 Connection of relay modules

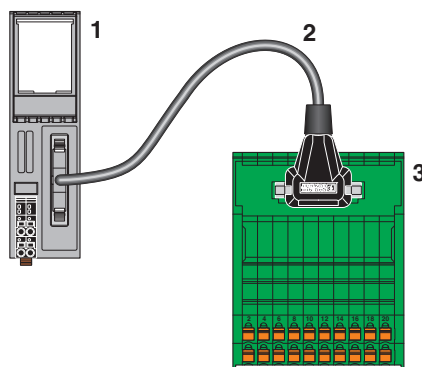

Figure 8-16 Connection of a termination board



For accessories, please refer to the module-specific data sheet.

### 8.10.5 Redundant signals

If you are using I/O modules redundantly, connect the modules as shown in [Figure 8-17](#). In the example, the two modules are located in two AxioLine F stations.

#### 8.10.5.1 Redundant digital inputs

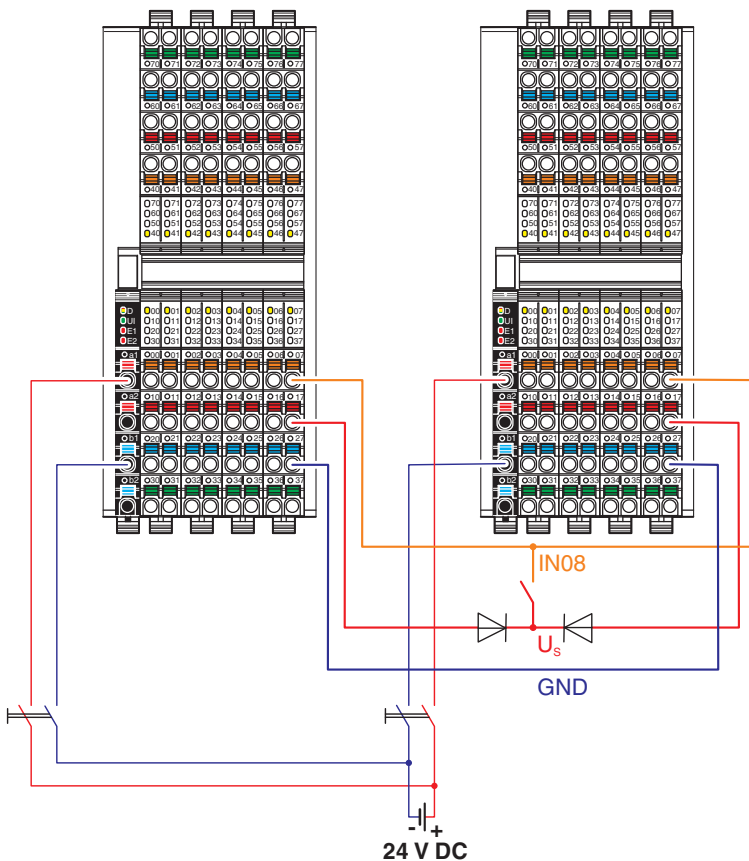

Figure 8-17 Example: connection for redundant use of digital inputs

- IN08 Digital input 8
- $U_S$  Sensor supply
- GND Reference potential



**CAUTION: Malfunction**

To avoid malfunction, make sure that the GND connection shown in [Figure 8-17](#) is established as the reference potential to the redundant signal inputs.

Make sure that, in the event of a short circuit of the sensor supply, the effects are limited by providing decoupling (longitudinal diode).

8.10.5.2 Redundant digital outputs

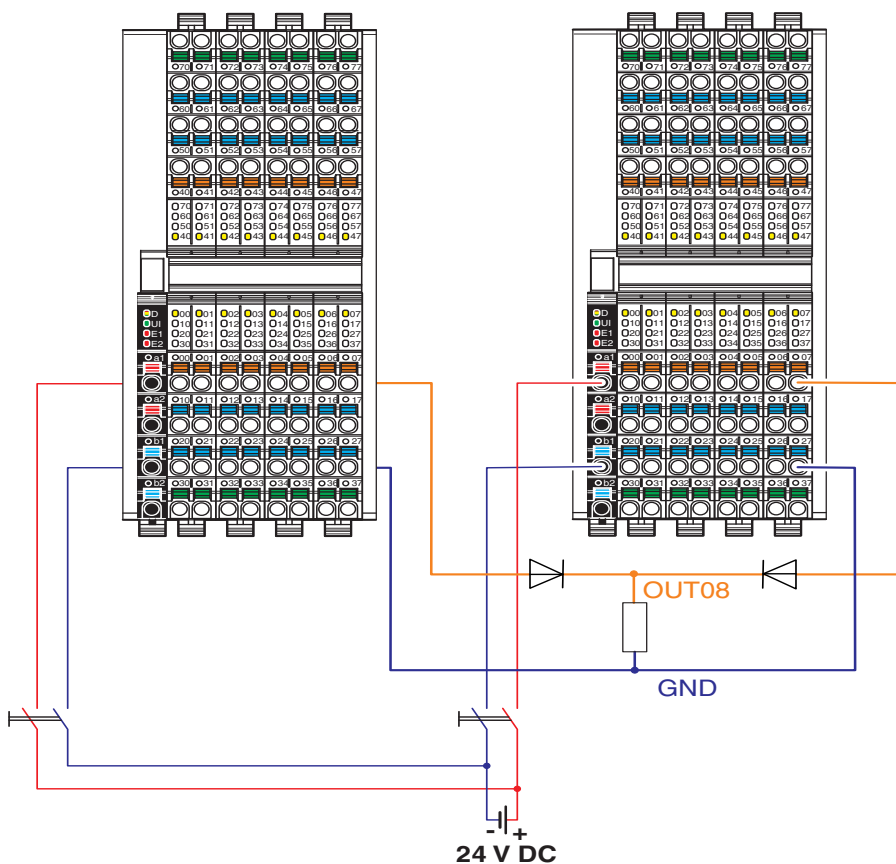

Figure 8-18 Example: connection for redundant use of digital outputs

- OUT08 Digital output 8
- $U_O$  Supply of digital outputs
- GND Reference potential



**CAUTION: Malfunction**

To avoid malfunction, make sure that the GND connection shown in [Figure 8-18](#) is established as the reference potential to the redundant signal outputs. Make sure that, in the event of a short circuit of the supply, the effects are limited by providing decoupling (longitudinal diode).

## 9 Grounding and shielding

### 9.1 Grounding concept

Within an Axioline F station, a distinction is made between functional grounding (FE) and protective grounding (PE).

**Protective grounding (PE)** Protective grounding protects people and machines against hazardous voltages. To avoid these dangers to the greatest extent possible, correct grounding, taking the local conditions into account, is vital.

**Functional grounding (FE)**



Functional ground is only used to discharge interference. It does not provide touch protection for people.

Functional grounding is used to improve immunity to interference. All devices must be grounded so that any possible interference from connectors for data transmission is shielded and discharged to ground.

#### 9.1.1 Protective ground (PE)

Protective ground is a low-impedance current path that minimizes the risk to the user in the event of an error. This includes a high voltage and/or high current error between an electrical circuit and ground.

According to the electrical design, the Axioline F low-voltage modules correspond to protection class II devices and therefore do not require grounding. However, IP20 protection is not sufficient for protection class II. This means that the modules only become real protection class 2 devices when used with a control cabinet or an installation box.

### 9.1.2 Functional ground (FE)

Functional ground is a low-impedance current path between circuits and ground. This current path is not intended as a protective measure but to improve immunity to interference instead, for example.

Functional ground is used in the 24 V DC area (protective extra-low voltage).

To ensure reliable functional grounding, please observe the following:

- 1 The Axioline F modules (controller, bus coupler, backplanes, I/O modules) have at least one FE spring (metal clip, 1 in Figure 9-1) at the bottom. This spring establishes an electrical connection to the DIN rail when the module is mounted. When using grounding terminal blocks to connect the DIN rail to protective ground, the modules are then also grounded when snapped onto the DIN rail.

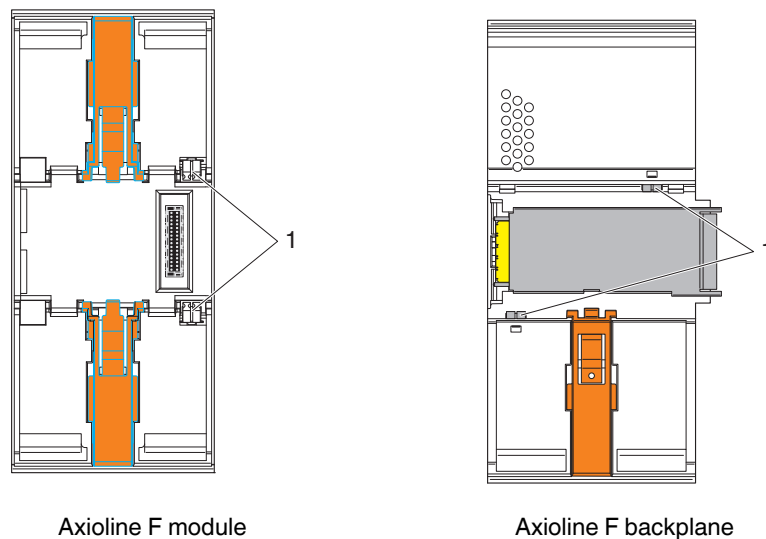

Figure 9-1 FE spring (1)

- 2 When using modules for surge protection (TRABTECH) connect their functional ground directly with the grounded DIN rail. Do **not** connect the functional ground of the modules for surge protection to an Axioline F module (e.g., to an FE contact of an Axioline F connector). This ensures that interference is discharged before it enters the Axioline F module. Only then is good electromagnetic compatibility ensured.

## 9.2 Shielding concept

Shielding is used to reduce the effects of interference on the system.

### 9.2.1 Shielding with Axioline F

In the Axioline F system, shielded cables are used with the following modules:

- Network cables
- Connecting cables
  - On modules for analog signals (analog input, analog output, temperature measurement)
  - On function modules and acquisition modules

Observe the following points when shielding:

- Connect the shield to a module before connecting the signal.
- Ensure a large surface connection of the shield.
- Make sure there is good contact between the shield and shield bus (synonyms: neutral busbar, busbar).
- Do not damage or squeeze the conductors.
- When connecting the shielding, observe the specifications for wiring.
- Make sure the shield is as close as possible to the signal terminal point.

### 9.2.2 Shielding when connecting analog sensors and actuators

- Always connect analog sensors and actuators with shielded, twisted pair cables.
- Connect the shield via a shield bus (see [Figure 9-9](#)).



When connecting the cables, observe the information in the module-specific data sheet.

- As a rule, shielding must only be connected directly to the PE potential on one side. This is to prevent any occurrence of equipotential bonding currents via the shielding (see [Figure 9-9](#) and [Figure 9-10](#)).
- If necessary, integrate the shielding concept for analog I/O cables in the system concept. For example, it is advisable to use a central FE shield connection at the control cabinet entry (see [Figure 9-10](#)).



For connecting the shield, Phoenix Contact recommends the AXL SHIELD SET Axioline F shield connection set or the shield connection clamp products from the “Installation and mounting material, grounding, and shielding” product range.

### 9.2.3 Connecting the shield using the Axioline F shield connection set



If you use Axioline F backplanes (AXL F BP SE4 or AXL F BP SE6), please observe [Section “Axioline F backplane” on page 97](#).

The shield connection set consists of two shield bus holders and two SK 5 shield connection clamps. It can be used to connect cable shields in an Axioline F station in the vicinity of the modules.

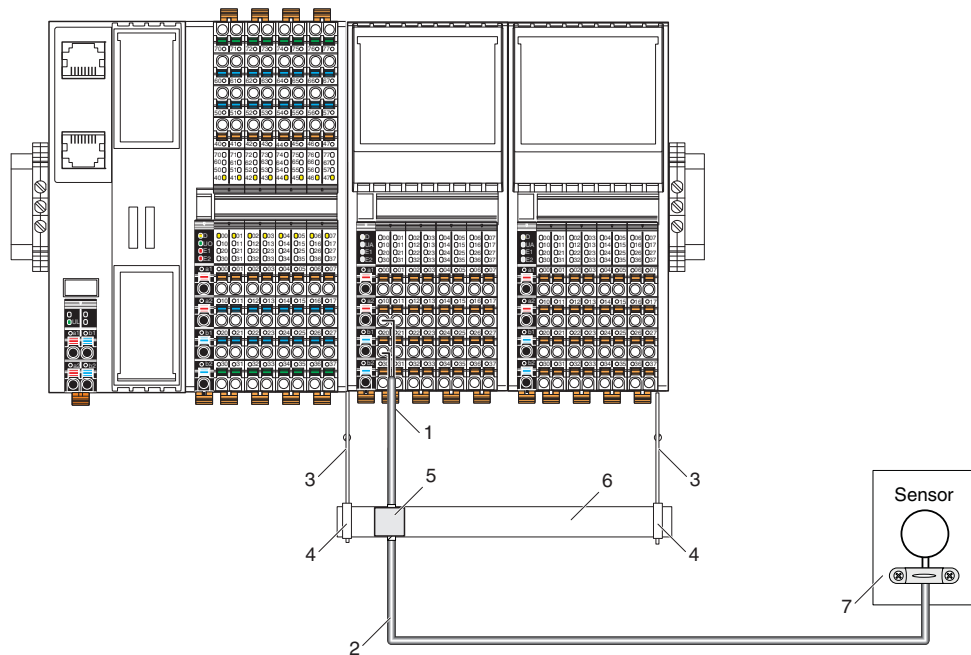

Figure 9-2 Connecting the shield with AXL SHIELD SET

- 1 Lead the analog cable into the connector, making sure to maintain the cable insulation.
- 2 Use shielded twisted pair cables.
- 3 Shield bus holder
- 4 SK 5 shield connection clamps (2 pcs. included in the AXL SHIELD SET) for securing the busbar (accessories) on the shield bus holder
- 5 Shield connection clamp for applying the shield on the busbar (SKS ..., see [Section “Ordering data for accessories” on page 130](#))  
Connect the shield directly to the FE potential.  
Connect the shield for the entire analog transmission path to FE potential at only one point. In this example, this point is the busbar.
- 6 Busbar (NLS-CU 3/10 ..., see [Section “Ordering data for accessories” on page 130](#))
- 7 Lead the sensor cable into the sensor, making sure to maintain the cable insulation.

### Axioline F shield connection set

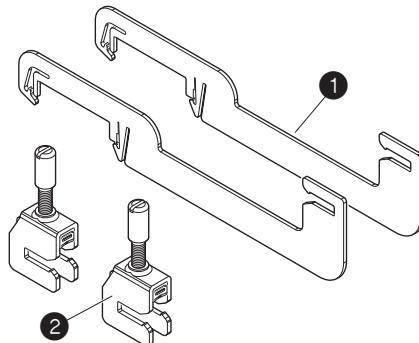

Figure 9-3 Set components

- 1 Shield bus holders (2 pcs.)
- 2 SK 5 shield connection clamps for securing the busbar on the shield bus holder (2 pcs.)

Contact is made with the shield on the busbar using shield connection clamps (both are available as accessories). Select the shield connection clamp according to the cable cross section and type (SK or SKS), see [Section "Material for shield connection" on page 134](#).

### Mounting

Mount the shield bus holders after mounting the bus base modules and before mounting the electronics modules.

Polished surfaces indicate the positions of the shield bus holders on the bus base modules.

The maximum distance between two adjacent shield bus holders should not exceed 215 mm (e.g., four modules with four connectors next to each other).

If the busbar is secured using more than two shield bus holders, distribute the holders equally over the width of the busbar.



If using a shield bus holder at the end of an Axioline F station, mount the shield bus holder after the last module. In this case, it is not positioned above a bus base module. Secure the shield bus holder using an end bracket (accessories).

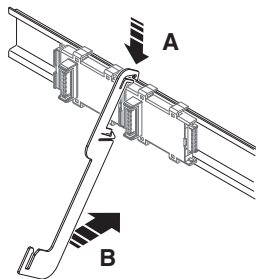

- Hook the shield bus holder onto the DIN rail.

Figure 9-4 Hooking on the shield bus holder

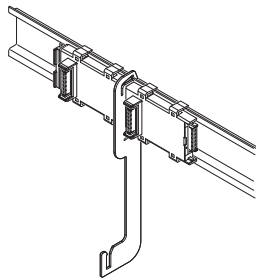

- Snap the shield bus holder onto the DIN rail.

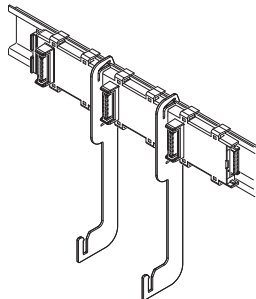

- Then snap on the second shield bus holder.

Figure 9-5 Snapping on the shield bus holders

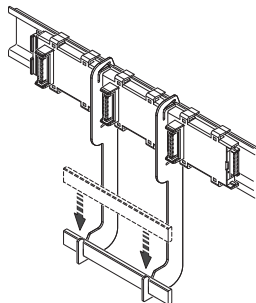

- Push the busbar into the shield bus holders.

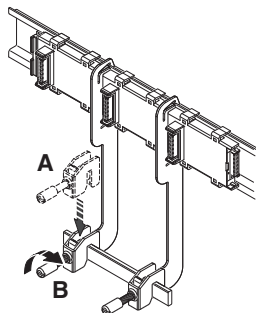

- Secure the busbar using the SK 5 shield connection clamps included in the scope of supply.

Figure 9-6 Mounting the busbars

## UM EN AXL F SYS INST

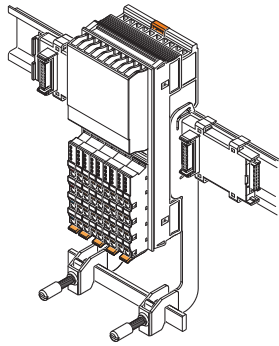

- Mount the electronics modules.

Figure 9-7 Mounting the electronics modules

**Removal**

For removal, use a screwdriver with a blade width of 4 mm (see accessories for examples).

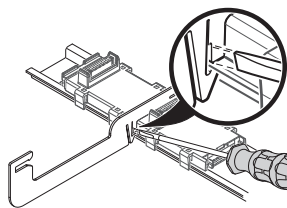

- First, remove the adjacent electronics modules (to the right and left of each shield bus holder).
- Insert the screwdriver in the release slot.

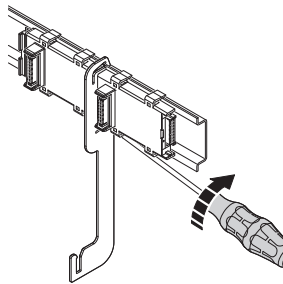

- Turn the screwdriver to release the locking clip from the DIN rail.
- Remove the shield bus holder.

Figure 9-8 Removing the shield connection



The locking clip may become deformed following contact with the screwdriver. In this case, bend it back into shape prior to reassembly.

## 9.2.4 Connecting the shielding to a busbar

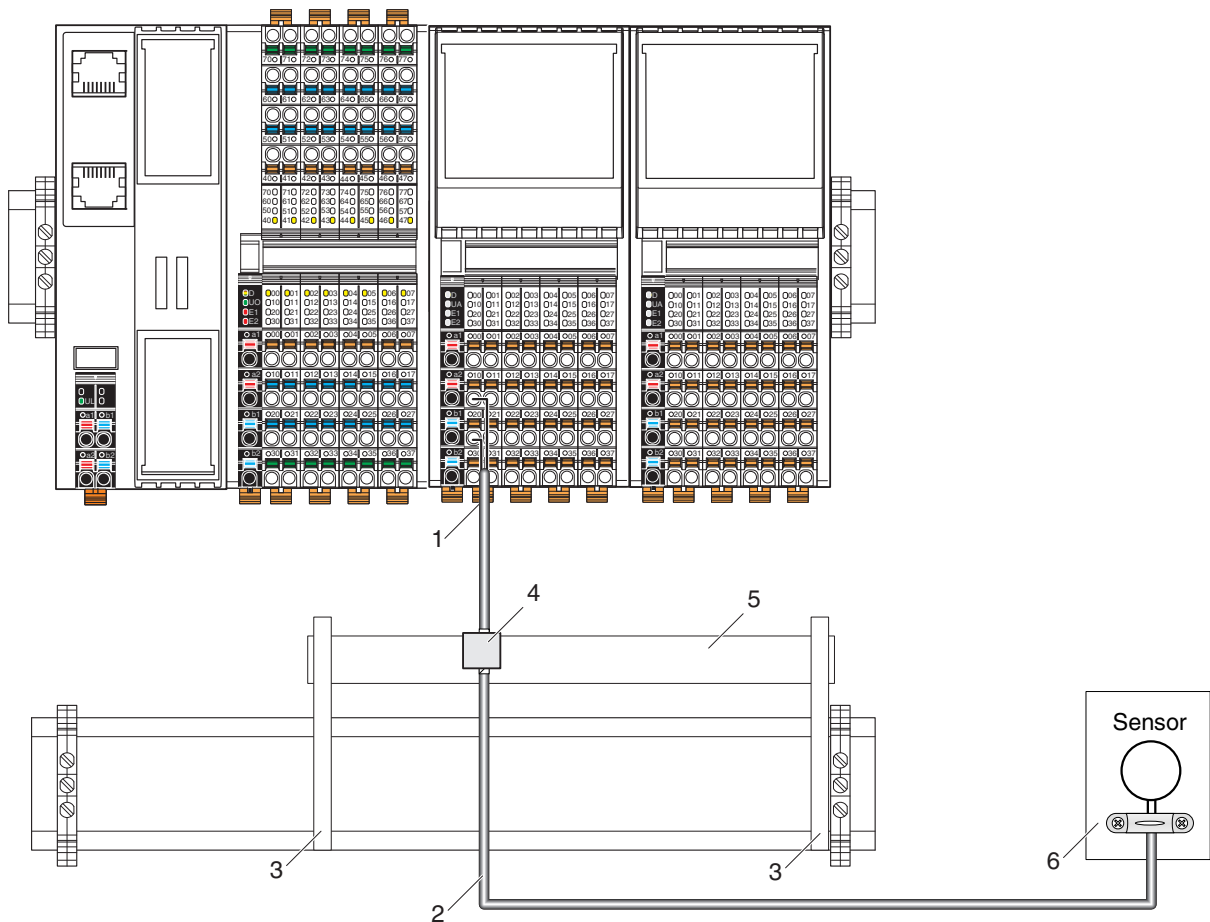

Figure 9-9 Connecting the shielding to a busbar

- 1 Lead the analog cable into the connector, making sure to maintain the cable insulation.
- 2 Use shielded twisted pair cables.
- 3 Support bracket (AB ..., see [Section "Ordering data for accessories" on page 130](#))
- 4 Shield connection clamp for applying the shield on the busbar (SKS ..., see [Section "Ordering data for accessories" on page 130](#))  
Connect the shield directly to the FE potential.  
Connect the shield for the entire analog transmission path to FE potential at only one point. In this example, this point is the busbar.
- 5 Busbar
- 6 Lead the sensor cable into the sensor, making sure to maintain the cable insulation.

### 9.2.5 Integrating analog shielding in a concept with central equipotential bonding at the control cabinet entry

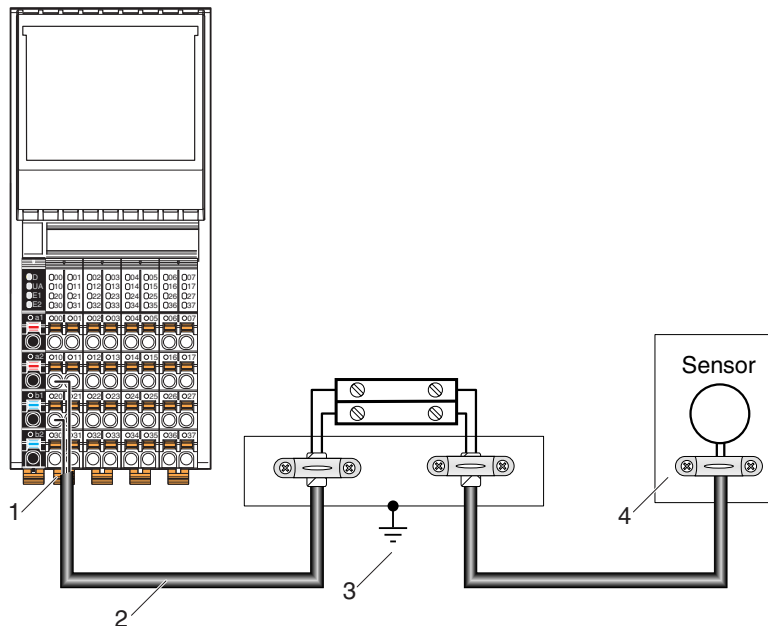

Figure 9-10 Integration of analog shielding in a concept with central equipotential bonding at the control cabinet entry

- 1 Lead the analog cable into the connector, making sure to maintain the cable insulation.
- 2 Use shielded twisted pair cables.
- 3 Connect the strain relief directly to the FE potential.  
Connect the shield for the entire analog transmission path to FE potential at only one point. In this example, this point is the marshalling level.
- 4 Lead the sensor cable into the sensor, making sure to maintain the cable insulation.



**NOTE: Functions may be impaired**

Observe the following when integrating the shielding of analog I/O cables in an equipotential bonding concept:

Direct connection to the FE potential must only be made at one point (e.g., at the central grounding point of the marshalling level).

## 10 Diagnostic and status indicators



If you use Axioline F backplanes (AXL F BP SE4 or AXL F BP SE6), please observe [Section “Axioline F backplane” on page 97](#).

All Axioline F modules are provided with diagnostic and status indicators for quick local error diagnostics. They enable the clear localization of system errors (bus errors) or I/O errors.

### Diagnostics

The diagnostic indicators (red, yellow, or green) provide information on the state of the module. In the event of an error, they provide information about the type and location of the error. The module is functioning correctly if all of the green LEDs are on.

### Status

The status indicators (yellow) indicate the status of the relevant input or output and of the connected I/O device.

### Extended diagnostics

Some modules have extended diagnostics. Short circuit or overload of the sensor supply, for example, can be detected and reported. If a short circuit occurs at an output, some output modules can diagnose each channel individually. Information regarding the supply voltage is also reported. Information about I/O errors is sent to the controller with precise details of the error type and is displayed using status indicators.



Diagnostic indicators D, UA, E1, E2 show the current status.

This status is not saved. This means, for example, that an open circuit or overrange is indicated via the LEDs. If the respective error has been removed and no other error has occurred, the LEDs indicate the error-free state again.

The error is not saved on the module. For some modules, however, the DiagState object (0018<sub>hex</sub>) is used to report some specific errors to the controller.



All possible positions for diagnostic and status indicators are equipped with light guides on the Axioline F connectors.

Since not every position has its own LED on the printed circuit board, there are some light guides without any function.

Examples:

AXL F AI8 1F: light guides 00 ... 07, 10 ... 17, 20 ... 27 and 30 ... 37 do not have a function.

AXL F DI32/1 1F: light guides 00 ... 07, 10 ... 17, 20 ... 27 and 30 ... 37 have a function.



For information regarding the diagnostic and status indicators on each module and their meaning, please refer to the module-specific documentation.

### 10.1 Indicators on controllers



For information regarding the diagnostic and status indicators of the controllers, please refer to the corresponding documentation.

## 10.2 Indicators on bus couplers

Bus couplers have power supply indicators, as well as network and module indicators.

Indicators for the power supply are located on the power connector. The other indicators are located on the module.

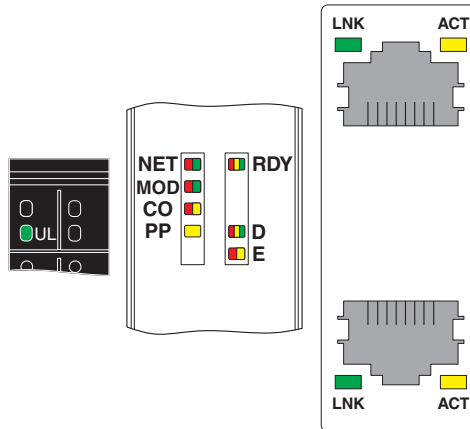

Figure 10-1 Indicators on a bus coupler (example: AXL F BK EIP)

All bus couplers have the following indicators:

Designation	Color	Meaning	State	Description
U <sub>L</sub>	Green	U <sub>Logic</sub>	On	Communications power supply present.
			Off	Communications power supply not present.
RDY	Green/ yellow/ red	Ready	Green on	Device is ready to operate.
			Flashing green/yellow	Undervoltage or overvoltage of communications power. Overtemperature.
			Yellow on	Firmware/bus coupler is booting.
			Flashing yellow	Firmware update is being performed.
			Flashing yellow/red	Firmware update has failed.
			Flashing red	Faulty firmware.
			Red on	Rotary encoding switches are set to an invalid/reserved position.
			Off	Device is not ready to operate.

## Diagnostic and status indicators

Designation	Color	Meaning	State	Description
D	Red/yellow/green	Diagnostics of local bus communication		
		Run	Green on	The station is ready to operate, communication within the station is OK. All data is valid. No malfunction is present.
		Active	Flashing green	The station is ready to operate, communication within the station is OK. The data is <b>not</b> valid. No valid data provided by the controller or higher-level network. There is no malfunction on the module.
		Ready	Yellow on	The station is ready to operate. No data is being exchanged.
			Flashing yellow	Access from Startup+ in I/O check mode
			Flashing yellow/red	Local bus error during active I/O check (when using Startup+)
			Flashing red	Local bus error during startup
			Red on	The station is ready to operate but has lost connection to at least one device. Possible causes: <ul style="list-style-type: none"> <li>– Configuration cannot be generated, information is missing from a device</li> <li>– Chip version of a device is &lt;V1.1</li> <li>– Desired configuration and actual configuration differ</li> <li>– Local bus device not connected</li> <li>– Maximum number of local bus devices exceeded</li> </ul>
		Power down	Off	Device is in (power) reset.
		E	Yellow/red	Error
Red on	I/O error at a local bus device			
Off	No I/O messages present.			

Further diagnostic and/or status indicators may also be available.



For information regarding the diagnostic and status indicators of the bus couplers and their meanings, please refer to the documentation for the bus couplers.

## 10.3 Indicators on I/O modules

The LEDs of the I/O modules are located on the connectors.

### 10.3.1 LEDs on the power connectors



Figure 10-2 LEDs on the power connectors (examples)

Designation	Color	Meaning	State	Description
D	Red/ yellow/ green	Diagnostics of local bus communication		
		Run	Green on	The device is ready to operate, communication within the station is OK. All data is valid. No malfunction is present.
		Active	Flashing green	The device is ready to operate, communication within the station is OK. The data is <b>not</b> valid. No valid data provided by the controller or higher-level network. There is no malfunction on the module.
		Device application not active	Flashing green/yellow	The device is ready to operate, communication within the station is OK. Output data <b>cannot</b> be output and/or input data <b>cannot</b> be read. There is a malfunction on the I/O side of the module.
		Ready	Yellow on	The device is ready to operate, but has still not detected a valid cycle after power on.
		Connected	Flashing yellow	The device is not (yet) part of the active configuration.
		Reset	Red on	The device is ready to operate, but has lost the connection to the bus head.
		Not connected	Flashing red	The device is ready to operate, but there is no connection to the previous device.
		Power down	Off	Device is in (power) reset.
U <sub>x</sub>	Green	U <sub>x</sub>	On	I/O supply is present.
			Off	I/O supply not present.
E1	Red/ yellow	Device error or warning Indicates messages that apply to the entire device.		
			Red on	Error (priority 1)
			Yellow on	Warning (priority 2)
E2	Red/ yellow	I/O error, channel error or warning (group message) Indicates messages that only apply to a single channel.		
			Red on	Error (priority 1)
			Yellow on	Warning (priority 2)

**Diagnostic and status indicators**

---

Voltages $U_x$ :		
$U_I$	( $U_{\text{Input}}$ )	Supply for digital input modules; sensor/encoder supply
$U_O$	( $U_{\text{Output}}$ )	Supply for digital output modules
$U_{IO}$	( $U_{\text{Input/Output}}$ )	Supply for digital input and output modules
$U_A$	( $U_{\text{Analog}}$ )	Supply for analog modules



For information regarding the diagnostic and status indicators on each module and their meaning, please refer to the module-specific documentation.

### 10.3.2 LEDs on the I/O connectors

The LEDs on the I/O connectors are numbered according to the terminal points. All LED locations are numbered even when they are not used.

Exception: modules with secure inputs or outputs (see module-specific documentation).

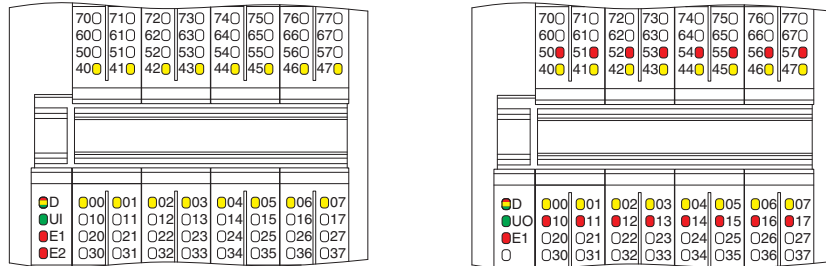

Figure 10-3 LEDs on the I/O connectors (e.g., AXL F DI16/4 2F, AXL F DO16/3 2F)

Table 10-1 LEDs on the I/O connector

Designation	Color	Meaning	State	Description
xx	Yellow	Status of the input or output	On	Corresponding input or output set.
			Off	Corresponding input or output not set.
yy	Red	Diagnostics of the output	On	Error at the output.
			Off	No error at the output.

xx Channel identification

yy Channel identification



Table 10-1 lists commonly used LEDs. Additional LEDs may also be found on the modules.

For information regarding the LEDs on each module and their meaning, please refer to the module-specific documentation.

### 10.4 Reporting diagnostics via PDI

The malfunctions indicated by the local diagnostic and status indicators are also mapped in PDI object 0018<sub>hex</sub> (DiagState).

Detailed information can be found in [Section “Objects for diagnostics” on page 140](#) and in the module-specific data sheet.

# 11 Axioline F backplane

The Axioline F backplane is intended for use in a station that is opened by an Axioline F bus coupler or an Axiocontrol.

Depending on the version, the backplane can accommodate four or six Axioline Smart Elements.

## 11.1 Housing versions

Two housing versions are available for the Axioline F backplanes, they are shown in [Figure 11-1](#).

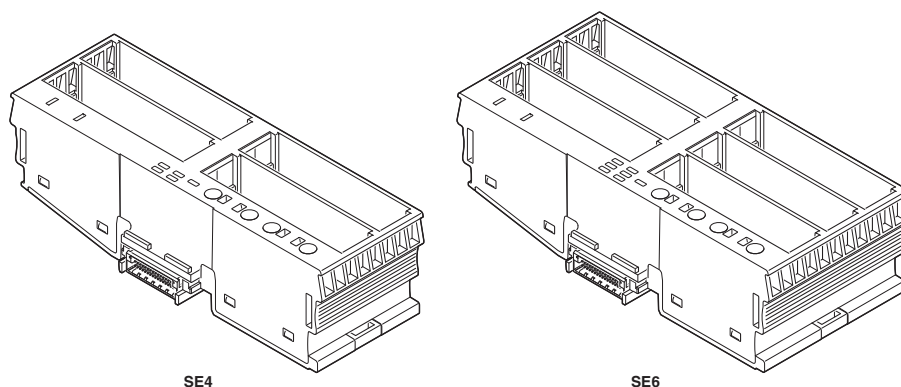

Figure 11-1 Housing versions SE4 and SE6

Table 11-1 Housing versions

Housing type	Special feature	Example	Design	Dimensions
SE4	Backplane, 4 slots for Axioline Smart Elements	AXL F BP SE4	<a href="#">Figure 11-2 on page 98</a>	<a href="#">Figure 11-5 on page 100</a>
SE6	Backplane, 6 slots for Axioline Smart Elements	AXL F BP SE6		<a href="#">Figure 11-6 on page 100</a>

## 11.2 Basic design

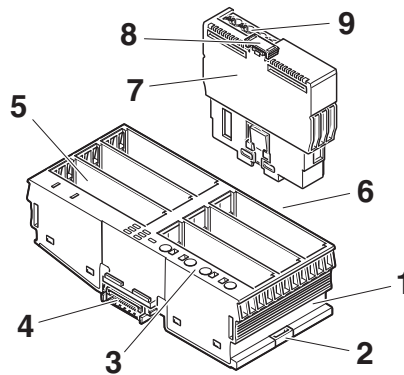

Figure 11-2 Design of an Axioline F backplane

- 1 Axioline F backplane**
- 2** Release mechanism (base latch)
- 3** Connections for the supply voltage
- 4** Connection to the upstream Axioline F backplane or an Axioline F bus base module
- 5** Slots for Axioline Smart Elements
- 6** Connection for the downstream Axioline F backplane or an Axioline F bus base module (not shown in the figure)
- 7 Axioline Smart Element**
- 8** Release mechanism
- 9** Connections for the I/O devices (if present)



For information on the Axioline Smart Elements, refer to the “Axioline Smart Elements” user manual.

### 11.3 Dimensions

All dimensions are in mm.

#### 11.3.1 Dimensions of the backplanes

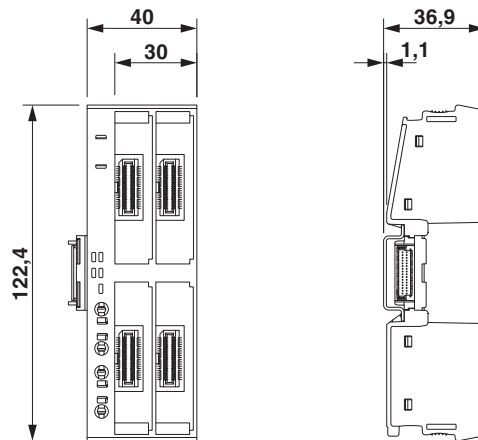

Figure 11-3 Nominal dimensions of the AXL F BP SE4

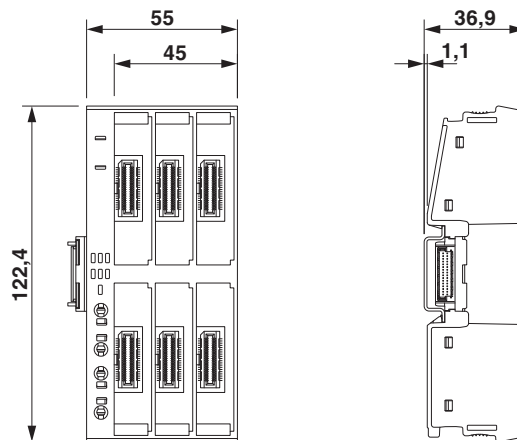

Figure 11-4 Nominal dimensions of AXL F BP SE6

### 11.3.2 Dimensions of the backplanes with inserted Smart Elements

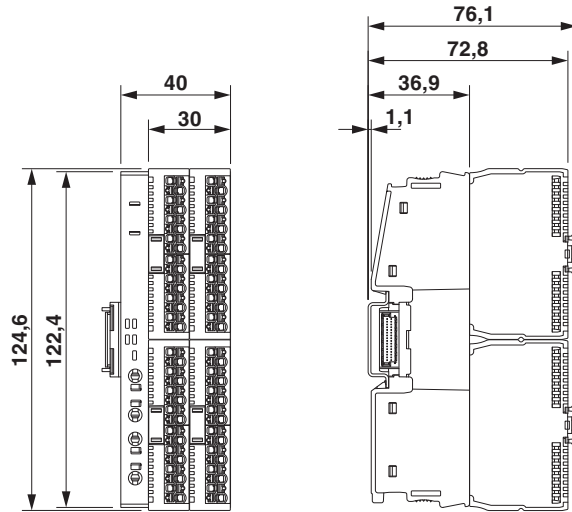

Figure 11-5 Nominal dimensions of AXL F BP SE4 with inserted Axioline Smart Elements

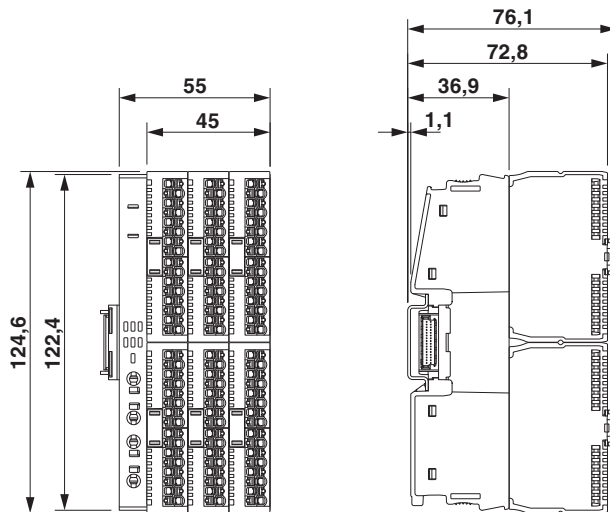

Figure 11-6 Nominal dimensions of AXL F BP SE6 with inserted Axioline Smart Elements

## 11.4 Color and marking

- Housing color** Axioline F backplanes are available in the housing color traffic gray A (RAL 7042).
- Slots** The slots of the backplane are marked (1 in [Figure 11-7](#)).
- Indication elements** Diagnostic and status indicators are marked with the function, e.g., D, 1 ... 6, UP (2 in [Figure 11-7](#)).
- Terminal points** On a backplane, terminal points for the 24 V voltage supply of the I/O supply are available. These are marked with UP+ (a1, a2) and UP- (b1, b2) (3 in [Figure 11-7](#)).

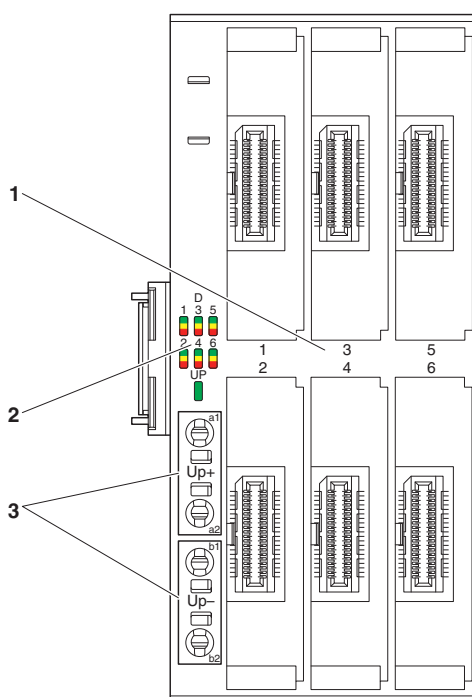

Figure 11-7 Markings of the slots, the LEDs and the terminal points

- 1 Markings of the slots
- 2 Markings of the diagnostic and status indicators
- 3 Markings of the terminal points for the 24 V voltage supply

**UM EN AXL F SYS INST**

**Equipment identification by the user**

You can apply an equipment identifier on the backplane. Two options are available:

- Stick on a label.
- Or
- Snap on a marker.

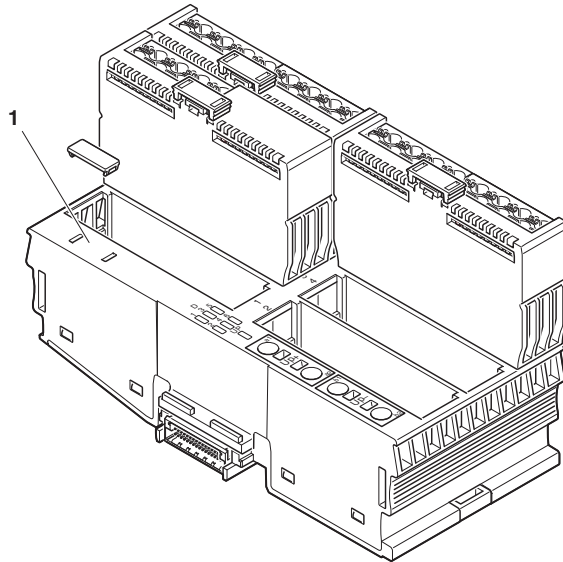

Figure 11-8 Individual module marking

**1** Position for equipment identification

You can use the following marking material provided by Phoenix Contact:

Table 11-2 Marking material

Description	Type	Order No.	Pcs./Pkt.
Label, continuous, cassette, transparent with black imprint, mounting type: adhesive, can be marked with THERMOFOX	MM-TML (EX4,2)R C1 TR/BK	0803979	1
Marker strip, roll, white, unmarked, can be marked with: THERMOMARK ROLL 2.0, THERMOMARK ROLL, THERMOMARK ROLL X1, THERMOMARK ROLLMASTER 300/600, THERMOMARK X1.2, mounting type: adhesive, for terminal block width: 5 mm, lettering field size: continuous x 5 mm	SK 5.0 WH:REEL	0805221	1
Markers, 24-section, unmarked, can be marked with THERMOMARK CARD and BLUEMARK, color: white	UM6M-TM (5X12)	0830928	10
Markers, sheet, white, unmarked, can be marked with: THERMOMARK CARD, THERMOMARK CARD 2.0, THERMOMARK PRIME, BLUEMARK ID, BLUEMARK ID COLOR, TOPMARK LASER, TOPMARK NEO, mounting type: snap into a high marker groove, for terminal block width: 5.2 mm, lettering field size: 4.17 mm x 11.3 mm	UCT6M-TM 5	0830756	10

## 11.5 Mounting and removing the backplane

### 11.5.1 Safety notes for mounting and removal

#### 11.5.1.1 General safety notes



**NOTE: Electrostatic discharge**

The modules contain components that can be damaged or destroyed by electrostatic discharge. When handling the modules, observe the necessary safety precautions against electrostatic discharge (ESD) according to EN 61340-5-1 and IEC 61340-5-1.



**NOTE: Damage to the electronics**

The maximum permissible current consumption  $U_P$  is 16 A.

Provide external protection for the 24 V supply  $U_P$ . If you use a fuse, the power supply unit must be able to supply four times the nominal current of the fuse. This ensures that the fuse trips reliably in the event of a fault.



**NOTE: Disregarding this warning may result in damage to the contacts or malfunction**

Before working on the backplane, disconnect the I/O devices and the supply from the power.

This means:

- Disconnect the connected I/O devices of all inserted Axioline Smart Elements from the power.
- Switch off the I/O supply voltage  $U_P$  at the backplane.
- Switch off the communications power supply  $U_L$  at the bus head of the station.



**NOTE: Damage to the connections**

To avoid damaging the connections when removing the backplane, observe the following:

- First separate the connections to the upstream and downstream modules (backplane or bus base module), by pushing the modules apart.
- Now disengage the backplane.

See [Section "Removing the backplane from the DIN rail" on page 107](#).



**NOTE: Damage to contacts**

There is risk of the terminal points getting damaged if they are mechanically overstrained.

- Relieve strain in the connected cables.

### 11.5.2 Basic information about mounting

Note the information in [Section "Basic information about mounting" on page 50](#).

### 11.5.3 Mounting the backplane and Smart Elements



Please refer to Section [“General safety notes” on page 103](#).

No tools are required for mounting the Axioline F backplanes.

Within an Axioline F station, an Axioline F backplane can be installed in any position. This means:

- Axioline F backplane directly downstream of the station head (controller or bus coupler)
- Axioline F backplane downstream of an Axioline F module
- Axioline F backplane downstream of an other Axioline F backplane

#### Example station

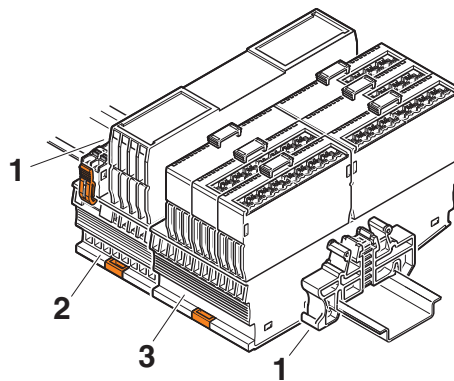

Figure 11-9 Example station for mounting

- 1 End bracket (CLIPFIX 35 or E/AL-NS 35)
- 2 Axioline F bus head (controller or bus coupler)
- 3 Axioline F backplane with inserted Smart Elements



If you use additional Axioline F modules downstream of the station head, observe Section [“Bus base modules, controllers, and bus couplers” on page 54 ff.](#)

### 11.5.3.1 Mounting the backplane

- First mount the end bracket on the DIN rail.
- Install the bus base module for the controller or bus coupler onto the DIN rail.
- Place the backplane on the DIN rail (Figure 11-10, A).
- First backplane: push the connection of the backplane into the connection of the previous bus base module (Figure 11-10, B).
- Place the controller or bus coupler onto the bus base module (Figure 11-10, C).
- See Section “Bus base modules, controllers, and bus couplers” on page 54.
- Subsequent backplanes: push the backplanes together (Figure 11-10, D).
- Mount the final end bracket on the DIN rail.

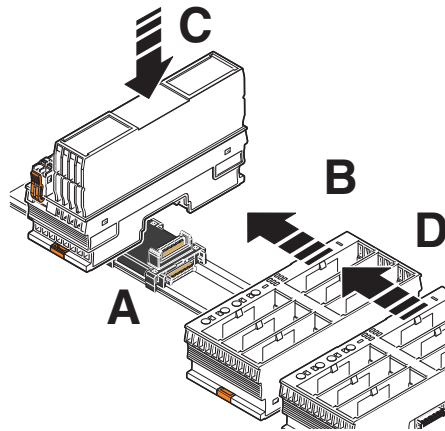

Figure 11-10 Connecting the backplane with the bus base module



In a station with Axioline F modules:

- It is not possible to snap a backplane to the previous bus base module if there is already an electronics module on it. In this case, first remove the electronics module before snapping on a backplane.
- If you want to mount an Axioline F module downstream of a backplane:
  - Place the associated bus base module on the DIN rail.
  - Push the bus base module into the appropriate connection of the backplane.
  - To do this, proceed as described in Section “Mounting and removing modules” on page 46.

### 11.5.3.2 Inserting Axioline Smart Elements

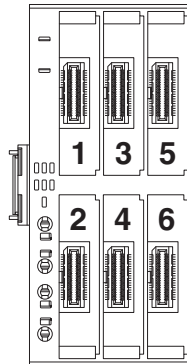

Figure 11-11 Slot numbering (example AXL F BP SE6)

- The slots are numbered as shown in [Figure 11-11](#).
- Insert the required Axioline Smart Elements into the appropriate slots of the Axioline F backplane ([Figure 11-12, A](#)).
- Push down the release mechanism ([Figure 11-12, B](#)). This locks the Smart Element in the backplane.

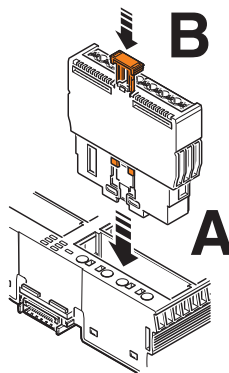

Figure 11-12 Inserting the Smart Element



Fill up all slots. If there is a slot you do not want to use, insert an AXL SE SC-A slot cover (Order No. 1088134).

## 11.5.4 Removing the backplane



Please refer to Section [“Safety notes for mounting and removal”](#) on page 103.

A standard tool, e.g., a bladed screwdriver with a blade width of 2.5 mm is necessary for removing modules.

### 11.5.4.1 Removing the Axioline Smart Elements

- Before removing a backplane, remove the Smart Elements from the backplane. To do so, pull up the release mechanism vertically (Figure 11-13, A) and remove the Smart Element (Figure 11-13, B).

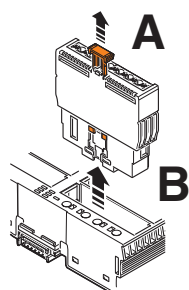

Figure 11-13 Removing a Smart Element

### 11.5.4.2 Removing cables

- Remove the cables that are connected to the backplane. See Section [“Removing cables from the terminal point”](#) on page 113.

### 11.5.4.3 Removing the backplane from the DIN rail



**NOTE: Damage to the connections**

To avoid damaging the connections when removing the backplane, observe the following:

- Separate the connections to the upstream and downstream modules (backplane or bus base module), by pushing the modules apart (Figure 11-14, A)
- Now disengage the backplane (Figure 11-14, B).

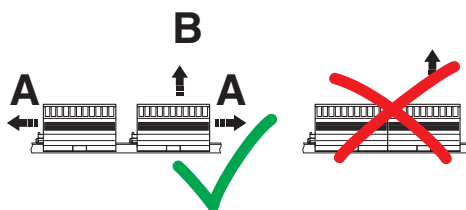

Figure 11-14 Separating and removing the module from neighboring modules

## UM EN AXL F SYS INST

If there is a device with a bus base module upstream of the backplane to be removed:

- Disengage the device from the bus base module (Figure 11-15, A).
- Pull the backplane out of the connection of the bus base module.
- See Section “Controller, bus coupler, and I/O modules” on page 57.

If there is a device with a bus base module downstream of the backplane to be removed:

- Remove the Axioline F module or the bus base module from the connection of the backplane.

Separating backplanes from each other:

- Disconnect the neighboring backplanes from one another by carefully inserting a bladed screwdriver into the groove between the backplanes (Figure 11-15, B1).
- Push the adjacent devices far enough apart that the backplane to be removed no longer has contact to the adjacent devices (Figure 11-15, B2, B3).
- Insert a suitable tool (e.g. bladed screwdriver) into the snap-on mechanism (base latch) of the backplane and release it (Figure 11-15, B4).
- Rotate the backplane away from the DIN rail. (Figure 11-15, B5).

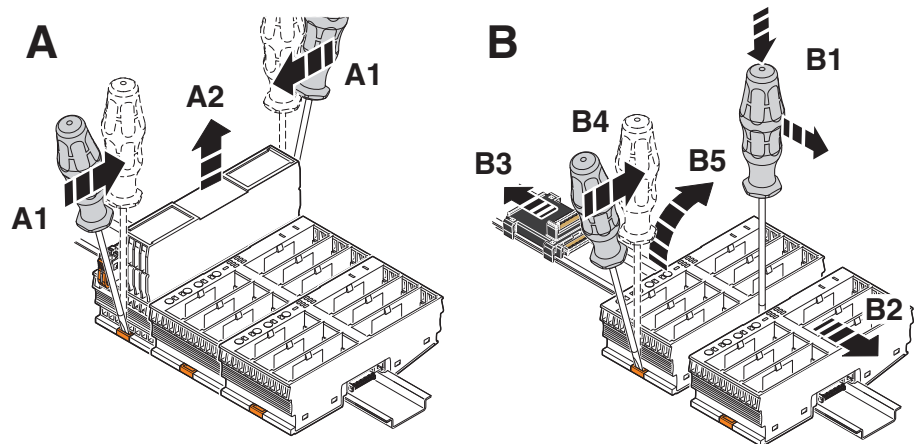

Figure 11-15 Removing the backplane

### Working in confined spaces



As shown in Figure 11-9 on page 104 there is a CLIPFIX 35 or E/AL-NS 35 end bracket upstream and downstream of the station.

The CLIPFIX 35 is 9.5 mm wide.

The E/AL-NS 35 is 10 mm wide.

If you remove the end bracket upstream and downstream of the station, you gain the space needed to remove the backplane from the neighboring modules.

### **11.5.5 Replacing the backplane**

- To replace a backplane, proceed as described in Section [“Removing the backplane”](#) on page 107 and [“Mounting the backplane and Smart Elements”](#) on page 104.
- Once replaced, restore all the necessary connections.

### **11.5.6 Mounting distances**

See [Section “Mounting distances”](#) on page 60.

## 11.6 Connecting and removing cables

### 11.6.1 Connections and cables at an Axioline F backplane

Connect the I/O supply voltage  $U_p$  for the Axioline Smart Elements to the terminal points of the backplane. You can use solid and stranded cables, with or without ferrules.

The backplanes are designed for a maximum current of 16 A.



The current can be reduced when used in applications in which a UL approval is required. Please observe any specifications in the documentation of the Smart Element used.

Please observe the following when wiring:

- Make sure to install the conductor in the middle of the wiring space, especially with small cross sections.

### 11.6.2 Conductor cross sections and stripping and insertion lengths

#### Conductor cross sections

Table 11-3 Permitted conductor cross sections

Conductor	Cross section
Solid	0.5 mm <sup>2</sup> ... 2.5 mm <sup>2</sup>
Stranded with ferrule without insulating collar (A ...)	
– According to DIN 46228-1 sleeve length 10 mm	
Stranded with ferrule with insulating collar (AI ...)	
– According to DIN 46228-4 sleeve length 8 mm	
– According to DIN 46228-1 sleeve length 10 mm	
Stranded without ferrule ( <b>only when actuation slot for inserting the conductor is used</b> )	



Stranded cables without ferrules are only suitable for Push-in connection technology **when the actuation slot is used**.

Table 11-4 Permitted AWG conductor cross sections

Conductor	Cross section
AWG	20 ... 14

**Stripping and insertion lengths****NOTE: Malfunction when the conductor is not securely fixed**

To ensure secure fixing and correct functioning:

Make sure that the stripping length of a conductor without ferrule or the insertion length of a conductor with ferrule corresponds to the specifications.

For crimping, we recommend pliers for trapezoidal crimp: CRIMPFOX 6 or CRIMPFOX 6T(-F), see [Section "Ordering data for accessories" on page 130](#).

According to the current state, these crimping pliers meet the general conditions regarding wiring space for the Axioline F backplane (according to internal cylindrical gauge DIN EN 60947-1 (DIN VDE 0660-100)-A1).

Conductor without ferrule: stripping length 8 mm

Conductor with ferrule: insertion length 8 mm or 10 mm

Ferrules: see [Section "Ordering data" on page 130](#).

**TWIN ferrules****NOTE: Malfunction when using wrong ferrule**

**TWIN ferrules are not permitted in the Axioline F system.**

### 11.6.3 Connecting cables

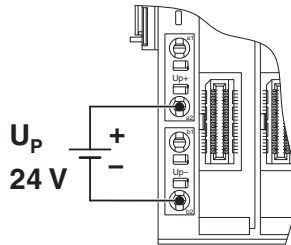

Figure 11-16 Terminal point assignment of the backplanes

When wiring, proceed as follows:

- Strip 8 mm off the cable.

#### Without tools

You can connect solid cables or cables with ferrules without tools.

- Insert the cable into the terminal point. It is clamped into place automatically.

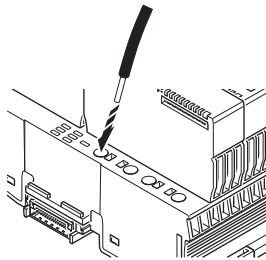

Figure 11-17 Connecting a cable without tools

#### With tools

- Open the spring by pressing the actuation slot with the screwdriver (Figure 11-18, A). Use, for example, a bladed screwdriver with a blade width of 2.5 mm. Phoenix Contact recommends the SZS 0,4x2,5 screwdriver (see Section “Ordering data” on page 130).
- Insert the cable in the terminal point (B).
- Remove the screwdriver to secure the conductor.

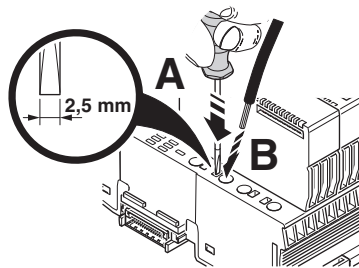

Figure 11-18 Connecting a stranded cable with tools

#### 11.6.4 Removing cables from the terminal point

- To remove a cable from the terminal point, press on the actuation slot using a suitable tool (e.g., bladed screwdriver with a blade width of 2.5 mm to max. 3.5 mm). This opens the terminal point (Figure 11-19, A).
- Remove the conductor (Figure 11-19, B).

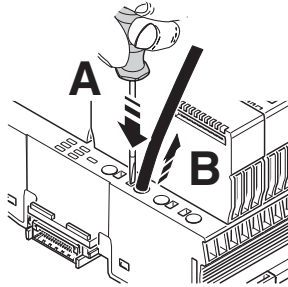

Figure 11-19 Removing the cable

## 11.7 Power supplies

The Axioline F backplanes are an integral part of the energy supply concept of Axioline F. See [Section “Connecting the power supplies” on page 69](#). See [Section “Power supply requirements” on page 70](#).

### 11.7.1 Supplying the Axioline F system with Axioline F backplanes

When using an Axioline F backplane within an Axioline F station, you must provide the following supply voltages:

- Supply voltage for the bus coupler or controller ( $U_L$ )
- Supply voltage for sensors and actuators

Unshielded cables are usually sufficient for connecting the power supplies. Connect them as shown in [Section “Connecting cables” on page 112](#).



For the terminal point assignment of the supply voltage connections, please refer to the module-specific documentation.

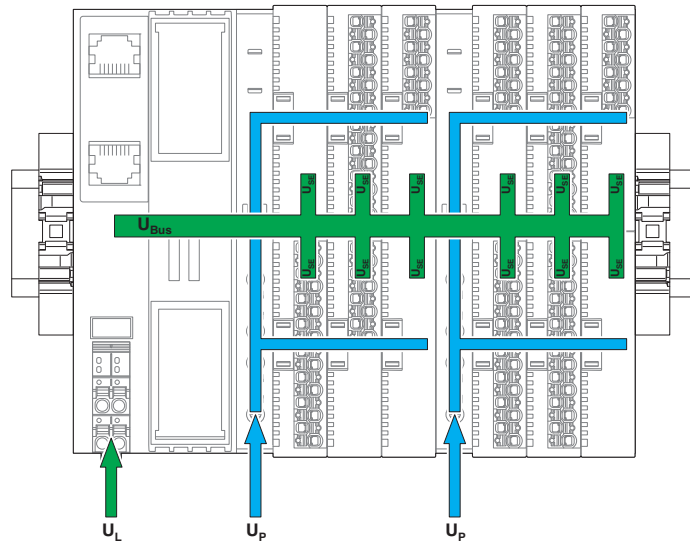

Figure 11-20 Supply voltages in an Axioline F station with Axioline F backplanes

Key:

$U_L$ ( $U_{Logic}$ )	Communications power supply See <a href="#">Section “Supply at the controller or bus coupler” on page 70</a> .
$U_{Bus}$ ( $U_{Bus}$ )	Power supply for the Axioline F local bus (generated from $U_L$ )
$U_{SE}$ ( $U_{Smart Element}$ )	Communications power supply for Axioline Smart Elements (generated at $U_{Bus}$ )
$U_P$ ( $U_{Periphery}$ )	I/O supply for Axioline Smart Elements

### 11.7.2 Supply at the Axioline F backplane

At an Axioline F backplane, you supply the I/O devices of the Axioline Smart Elements.

The voltage supply for the I/O devices ( $U_P$ ) should be installed and fused independently of the communications power ( $U_L$ ). In this way, the local bus can be operated even if some I/O devices are switched off. This also prevents unnecessary interference couplings between I/O and logic.

The use of separate power supply units for  $U_L$  and  $U_P$  may also be necessary in environments with a lot of interference.

### 11.7.3 Jumpers, potential forwarding, and fusing

In the backplane, terminal points  $U_{P+}$  (a1 and a2) as well as terminal points  $U_{P-}$  (b1 and b2) are jumpered. You can therefore use one of the terminal points for supply and the second terminal point for forwarding a potential.

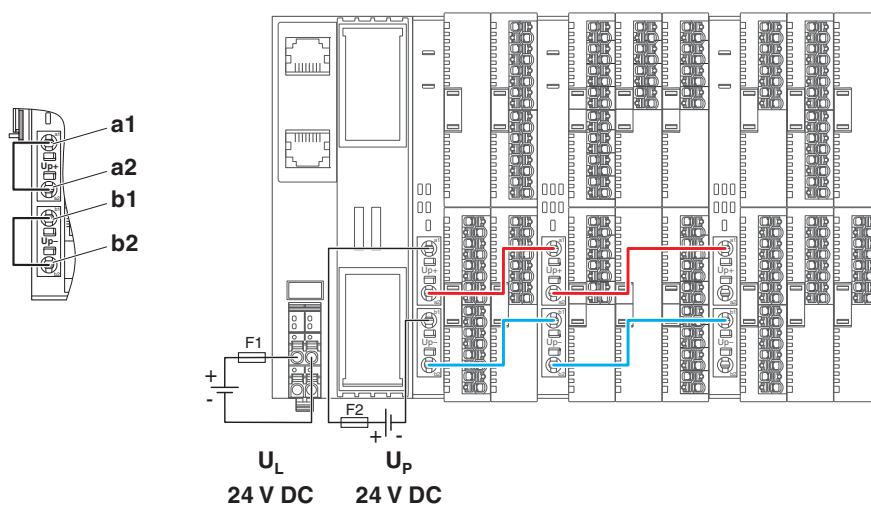

Figure 11-21 Jumpering the terminal points and example of potential forwarding

F1, F2 Protecting the supply voltage using suitable fuses (see module-specific documentation)



**NOTE: Module damage when I/O supply  $U_P$  is overloaded**

Two key figures apply for the I/O supply:

- Current consumption  $U_P$  at each Smart Element slot: **max. 6 A**
- Permissible total current at  $U_P$  supply: **max. 16 A**
- Make sure that no Smart Element draws more than 6 A at  $U_P$ .
- Make sure that all Smart Elements that have been installed onto a backplane together do not draw more than 16 A.
- If you conduct the potential to the next backplane: Make sure that the total current of 16 A is not exceeded.
- Protect the supply accordingly.

## 11.8 Grounding and shielding

For the Axioline F backplanes, the specifications on grounding and shielding as set out in [Section “Grounding and shielding” on page 82](#) apply.



If, for shielded cables on Smart Elements, you want to connect the shielding using an Axioline F shield connection set, please observe the following:

You cannot place the shield bus holders next to an Axioline F backplane. This means:

- If there are Axioline F modules in your station:  
Place the shield bus holders at a suitable position between two Axioline F modules respectively.
- If there are no Axioline F modules in your station:  
Place the shield bus holders upstream and downstream of the station, so that they are fixed by the end brackets.

Or:

- Connect the shielding to a busbar.

## 11.9 Diagnostic and status indicators

The Axioline F backplanes are provided with diagnostic and status indicators for quick local error diagnostics. They enable the clear localization of system errors (bus errors) or I/O errors.

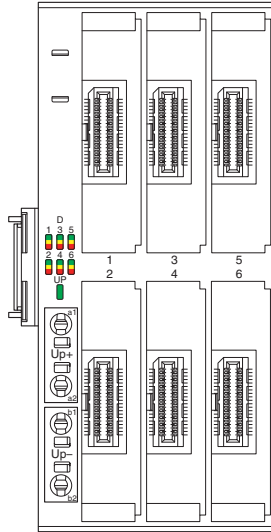

Figure 11-22 LEDs on an Axioline F backplane

One D LED (red, yellow, green) is assigned to each slot for a Smart Element.

Each D LED signals:

- The state of the local bus of the assigned slot.
- The state of the I/O devices of the Smart Element.

The UP LED signals the state of the I/O supply voltage.

## UM EN AXL F SYS INST

Designation	Color	Meaning	State	Description
D 1 ... 4 or 1 ... 6	Red/ yellow/ green	Diagnostics of local bus communication for each Smart Element interface		
		Run	Green on	The device is ready to operate, communication within the station is OK. All data is valid. No malfunction is present. – The connection to the controller is present.
		Active	Flashing green	The device is ready to operate, communication within the station is OK. The data is <b>not</b> valid. No valid data provided by the controller or higher-level network. There is no malfunction on the module.
		Device application not active	Flashing green/yellow	The device is ready to operate, communication within the station is OK. Output data <b>cannot</b> be output and/or input data <b>cannot</b> be read. There is a malfunction on the I/O side of the module. – The controller is providing valid process data.
				– There is a malfunction on the I/O side of the Smart Element.
				– The Smart Element cannot process the I/O data.
		Ready	Yellow on	The device is ready to operate, but has still not detected a valid cycle after power on. – There has been no communication since the last power-up.
		Connected	Flashing yellow	The device is not (yet) part of the active configuration. – There is an empty slot before the Smart Element.
				– The Smart Element before the slot blinking yellow or red is not connected to the slot.
		Reset	Red on	The device is ready to operate, but has lost the connection to the bus head. – The local bus is interrupted. The LED blinking red shows the location of the error. – After power-up: there is a non-projecting Smart Element on the slot.
		Not connected	Flashing red	The device is ready to operate, but there is no connection to the previous device.
		Power down	Off	Device is in (power) reset. – The supply voltage not present. – The Smart Element is not plugged in.
U <sub>P</sub>	Green	U <sub>P</sub> eriphery	On	I/O supply U <sub>P</sub> present.
			Off	I/O supply U <sub>P</sub> is not present.

---

## 12 Process, parameter, and diagnostic data

The Axioline F local bus is used for the transmission of process data and parameter data.

### 12.1 Process data

Axioline F devices have at least one byte of process data. If less than eight bits are used, they occupy the least significant bits of the byte.

The significance of the data corresponds to the Motorola format (Big Endian).

The significance of the data bytes declines as the number goes up.



For the process data assignment and the assignment of the process data to the terminal points of a module, please refer to the module-specific data sheet.

### 12.2 Parameter and diagnostic data (PDI channel)

Parameter and diagnostic data as well as other information is transmitted via the PDI channel (PDI = Parameters, Diagnostics, and Information).

The PDI channel is used in addition to the process data channel in the Axioline F system for the demand-oriented, acyclic transmission of parameter and diagnostic data as well as other information. Each Axioline F I/O module is equipped with this acyclic channel for exchanging acyclic data.

Read and write services can be used to access communication objects created in the Axioline F I/O module via the PDI channel. These objects can be used, for example, to set measuring ranges, to specify the substitute value behavior of outputs in the event of a bus error, or to read I/O diagnostics details.

## 12.3 Saving of parameters

Every Axioline F module has parameters. They can be read or written or can be read and written. The parameters that can be written are saved every time a change is made.

Some parameters are defined as startup parameters in the device description file of each module.

### Startup parameters (Flash)

Startup parameters are stored retentively (in a non-volatile way, permanently) in the flash memory.

Startup parameters include the application object parameters, e.g., substitute value, filter time etc. As soon as valid parameters are specified for these objects, they are stored retentively on the module.

Due to the storage technology used, parameters that are stored retentively can only be written for a specific number of times (100,000 up to 1,000,000 times, typically). They are not suitable for being changed cyclically.

**NOTE: Damage to the flash memory during cyclic write access**

The flash memory is only designed for a limited number of write access operations. Make therefore sure that write access operations are not performed too often and, in particular, not cyclically.

**Observe this behavior when programming function blocks.**

### Other parameters (RAM)

Other parameters are stored temporarily (in a volatile way) in the RAM.

## 13 Software support

### 13.1 Overview of the software

The following software from Phoenix Contact supports you when working with Axioline F:

Project+	Planning and configuration
PROJECT complete	Planning and marking
Startup+	Startup and parameterization of Axioline F stations
PC Worx	PLC programming for conventional controllers
PLCnext Engineer	PLC programming for PLCnext Control

You can also integrate Axioline F into any other system, e.g., via GSDML in STEP 7 or via ESI in TwinCAT<sup>®</sup>, etc.



For the software for supporting safety modules, please refer to the module-specific documentation.



For detailed information on the software of Phoenix Contact, visit [phoenixcontact.net/products](http://phoenixcontact.net/products) under "Software".

### 13.2 Project+

When it comes to configuring electrotechnical equipment for an automation application, Project+, the expert solution, is there to help.

With no training required, you can create a functional station in accordance with your specifications very quickly with Project+. In addition, you can generate information for subsequent steps in the automation process.

**Workflow:** enter the required I/O signals for connecting sensors and actuators in your application. Project+ then determines the optimum product selection from the Axioline F and In-line product ranges from Phoenix Contact. The selected devices are combined to create a station in accordance with the configuration rules. You are immediately provided with a graphical structure plan and a bill of material including product descriptions.

### 13.3 PROJECT complete

The PROJECT complete planning and marking software supports the entire control cabinet manufacturing process. The program features an intuitive user interface that enables the individual planning, automatic checking, and direct ordering of terminal strips.

## 13.4 Startup+

The Startup+ software enables easy selection and configuration of an Axioline F station via a Windows user interface. The tool, for example, offers the following functions:

- Connection to the bus coupler via RJ45 or USB interface
- Reading the connected bus; all modules will be displayed
- Reading and writing module process data
- Parameterization of the modules (only online, no adoption in PC Worx or STEP 7)
- I/O module and the bus coupler diagnostics



Startup+ is available on the Internet at [phoenixcontact.net/products](http://phoenixcontact.net/products).

The software is available for download and can be found in the download area of each Axioline F bus coupler.

Here you will also find a quick start guide for using the Axioline F station under Startup+.

## 13.5 PC Worx

Axioline F is supported by “AX SW Suite” 1.50, Service Pack 3 or later.

PC Worx is the consistent programming software for all conventional controllers from Phoenix Contact. It combines programming according to IEC 61131, fieldbus configuration for INTERBUS, PROFINET, and Modbus, as well as system diagnostics in a single software solution.

Depending on the number of I/Os to be supported, you can choose between two versions: PC Worx Basic and PC Worx Pro.

As an introduction, you can use the software as a free express version for selected Inline and Axioline controllers.

In addition to the familiar functions, the tool offers the following special functions for Axioline F:

- Reading the connected bus; all modules will be displayed
- Startup parameterization of the module via a drop-down menu
- Automatic checking of the maximum number of modules
- Automatic checking of the communications power
- Display of the device rating plates stored on the modules; access via read and write services

## 13.6 PLCnext Engineer

The PLCnext Engineer software is an engineering software platform for Phoenix Contact automation controllers.

The new PLCnext Engineer is a flexible engineering platform for programming according to IEC 61131-3. The platform combines all engineering tasks into just one tool, thus enabling user-friendly configuration, standard and safe programming, web-based visualization, and diagnostics for the complete system. Furthermore, you can extend PLCnext Engineer individually with function add-ins.

## 14 Device replacement, device defect and repair

### 14.1 Device replacement

Axioline F modules can be replaced, if necessary.

If you want to replace an Axioline F module, proceed as follows:

- Observe the safety notes in [Section 7.1, "Safety notes for mounting and removal"](#).
- If necessary, disconnect the wiring as shown in [Section 8.6, "Removing cables from the terminal point"](#).
- Replace the Axioline F module in your application with a new Axioline F module. See [Section 7.7, "Replacing a module"](#).
- If necessary, connect the supply and the I/O devices. See [Section 8, "Connecting or removing cables"](#).

#### Observe the device type and version

The new module must meet the following requirements:

- Same device type
- Same or later version

### 14.2 Device defect and repair

#### Do not open the housing

Repairs may only be carried out by Phoenix Contact. Do not open the housing. If the housing is opened, the function of the device can no longer be ensured.

#### Defective devices

- Please contact Phoenix Contact.

# 15 Maintenance, decommissioning, and disposal

## 15.1 Maintenance

Axioline F modules are maintenance free.

## 15.2 Decommissioning and disposal

Carry out decommissioning according to the requirements of the machine or system manufacturer.

When decommissioning, ensure the following for the Axioline F modules used:

**The device continues to be used only as intended:**

- Observe the storage and transport requirements.  
See [Section “Transport, storage, and unpacking” on page 45](#).

**The device is not used any more:**

**Device disposal**

- Do not dispose of the device with household waste; it should instead be disposed of in accordance with the currently applicable national regulations.

**Packaging disposal**

- Dispose of packaging materials that are no longer needed (cardboard packaging, paper, bubble wrap sheets, tubular bags, etc.) with household waste in accordance with the currently applicable national regulations.

## 16 Technical data and ordering data



### Observe additional documentation

For the system data of your network, please refer to the corresponding documentation.

If you are using Axioline F in a system with other product groups, also observe the technical data for these product groups. For this technical data, please refer to the associated documentation.

For safety applications, refer to the documentation for the safety modules used.

Please refer to the associated documentation when using an AXC controller.



The following values are standard values for the preferred mounting position (wall mounting on horizontal DIN rail).

**For different values, please refer to the module-specific documentation.**

The technical data does not claim to be complete. Technical modifications reserved.

### 16.1 Technical data

#### System data

Number of devices supported in an Axioline F station      63 devices, maximum



Each Axioline F module and each Axioline Smart Element is a device.

Maximum current consumption of the Axioline F modules      See module-specific data sheet



When configuring an Axioline F station, observe the communications power supply through the bus coupler, the controller or the power module, as well as the current consumption of each device. This data may vary depending on the module and is given in the module-specific documentation. Create a new station or install a power module for the communications power if the maximum current consumption at  $U_{BUS}$  is reached. In addition, the maximum number of devices may be limited by the controller/bus coupler system data. Observe the information in the module-specific documentation.

See also [Section "Maximum number of modules" on page 52](#).

## UM EN AXL F SYS INST

**General data (standard values; for deviations see module-specific documentation)**

Ambient temperature	
Ambient temperature (operation)	-25°C ... +60°C
Ambient temperature (operation) for XC versions	-25°C ... +60°C (standard) -40°C ... +70°C (extended, see <a href="#">Section "Tested successfully: use under extreme ambient conditions" on page 26</a> and information in the module-specific data sheet)
Ambient temperature (storage/transport)	-40°C ... +85°C
Temperature change	5 K/min (no condensation permitted)
Permissible humidity (operation/storage/transport)	5% ... 95% (non-condensing)
Permissible air pressure (operation/storage/transport)	70 kPa ... 106 kPa (up to 3000 m above sea level)
Degree of protection	IP20
Protection class	Low-level signal: III, IEC 61140, EN 61140, VDE 0140-1 Low voltage, mounted in an adequate housing with at least IP54 protection: II, IEC 61140, EN 61140, VDE 0140-1
Air clearances and creepage distances	Low-level signal: according to EN 60664-1 Low voltage: according to EN 61010-2-201
Housing material	Plastic
Pollution degree	Low-level signal: 2, EN 60664-1 Low voltage: 2, EN 61010-1
Overvoltage category	Low-level signal: II, EN 60664-1 Low voltage: III, EN 61010-1



Do not use the device in an atmosphere that contains corrosive gas.

**Mechanical tests (standard values; for deviations see module-specific documentation)**

Vibration resistance according to EN 60068-2-6/ IEC 60068-2-6	5g
Shock testing according to EN 60068-2-27/IEC 60068-2-27	30g
Bump endurance test according to EN 60068-2-27/ IEC 60068-2-27	10g

**Conformance with EMC Directive 2004/108/EC  
(for deviations and detailed values see module-specific documentation)**

**Immunity test according to EN 61000-6-2**

Electrostatic discharge (ESD) EN 61000-4-2/IEC 61000-4-2	Criterion B
Electromagnetic fields EN 61000-4-3/IEC 61000-4-3	Criterion A
Fast transients (burst) EN 61000-4-4/IEC 61000-4-4	Criterion B
Transient overvoltage (surge) EN 61000-4-5/EN 61000-4-5	Criterion B
Conducted interference EN 61000-4-6/IEC 61000-4-6	Criterion A

**Axioline F modules:**

**Noise emission test according to EN 61000-6-3** Class B

**Axioline F backplane**

**Noise emission test according to EN 61000-6-4** Class A



The Axioline F backplanes and the Axioline Smart Elements to be inserted into the backplanes are a class A product.

The noise emission meets the requirements for industrial environments.

- Note this when combining products approved for residential environments.
- Observe the requirements for noise emission for electrical and electronic equipment (EN 61000-6-4/IEC 61000-4-6).
- Implement appropriate precautions against noise emission.

**Low-voltage modules: developed according to IEC 61850-3  
(for deviations and detailed values see module-specific documentation)**

Electrostatic discharge (ESD), EN 61000-4-2/ IEC 61000-4-2	Criterion A
Electromagnetic fields EN 61000-4-3 / IEC 61000-4-3	Criterion A
Fast transients (burst) EN 61000-4-4/IEC 61000-4-4	Criterion A
Transient overvoltage (surge), EN 61000-4-5/ IEC 61000-4-5	Criterion A
Conducted interference EN 61000-4-6/IEC 61000-4-6	Criterion A
Immunity against magnetic fields, EN 61000-4-8/ IEC 61000-4-8	300 A/m continuous, 1000 A/m for 1 s
Immunity against attenuated oscillating magnetic fields, EN 61000-4-10/IEC 61000-4-10	100 A/m
Immunity to conducted common mode interference, EN 61000-4-16/IEC 61000-4-16	30 V continuous, 300 V for 1 s
Attenuated oscillating waves EN 61000-4-18/ IEC 61000-4-18	1 kV symmetrical, 2.5 kV asymmetrical
<b>Noise emission test according to EN 61000-6-3</b>	Class B

## UM EN AXL F SYS INST

### Interface for Axioline F local bus

Connection method	Bus base module, backplane
Transmission speed	100 Mbps

### 24 V supply ( $U_L$ , $U_I$ , $U_O$ , $U_{IO}$ , $U_A$ , $U_P$ )

Nominal voltage	24 V DC
Ripple	$\pm 5\%$
Maximum permissible voltage range	19.2 V DC ... 30.0 V DC (all tolerances included, ripple included)
Connection	Axioline F connector (Axioline F modules) Terminal points of the backplane (Axioline F backplane)



The Axioline F local bus supply (communications power)  $U_{BUS}$  is generated from communications power  $U_L$  (24 V).

### Axioline F local bus supply (supplies the bus logic of the connected modules)

Comment	<p>The communications power <math>U_L</math> is supplied on the bus coupler, controller or power module for the communications power.</p> <p>The communications power <math>U_{BUS}</math> is generated from this communications power <math>U_L</math> and distributed over the bus base modules. These two voltages are not electrically isolated.</p> <p>The current through the local bus <math>I_{BUS}</math> is short-circuit proof.</p>
Connection	Bus base module, backplane
Communications power ( $U_{BUS}$ )	5 V DC
Maximum load current in the local bus ( $I_{BUS}$ )	See controller, bus coupler or power module documentation

### Voltage dips and interruptions of the I/O supply

Degree of severity PS1	Interrupt time <1 ms
Time interval between voltage dips	<1 s
Behavior	Criterion A A supply voltage dip of <1 ms has no effect.
Degree of severity PS2	Interrupt time <10 ms
Time interval between voltage dips	<1 s
Behavior	Criterion C Bus disconnection, all system outputs are reset.



Die IEC 61131-2 requires power failure protection of 10 ms. To meet this requirement, use only power supply units (230 V AC / 24 V DC, 4000 V AC / 24 V DC) that support mains buffering for at least 10 ms.

**Axioline F connector/connection method/cable cross sections**

For electrical and/or thermal reasons, it may not be possible to use the minimum conductor cross sections specified here for certain modules. Therefore, always observe the information in the module-specific documentation.

Designation	Axioline F connector
Connection method	Push-in connection
Maximum load capacity of the contacts	8 A
Cable cross section (typical)	0.2 mm <sup>2</sup> ... 1.5 mm <sup>2</sup> ; AWG 24 ... 16 See <a href="#">Section "Conductor cross sections and stripping and insertion lengths" on page 63</a>
Stripping lengths	8 mm or 10 mm; See <a href="#">Section "Conductor cross sections and stripping and insertion lengths" on page 63</a>

**Terminal points of the Axioline F backplane/connection method/cable cross section**

Designation	Terminal points of the Axioline F backplane
Connection method	Push-in connection
Maximum load capacity of the contacts	16 A
Cable cross section (typical)	0.5 mm <sup>2</sup> ... 2.5 mm <sup>2</sup> ; AWG 20 ... 14 See <a href="#">Section "Conductor cross sections and stripping and insertion lengths" on page 110</a>
Stripping lengths	8 mm or 10 mm; See <a href="#">Section "Conductor cross sections and stripping and insertion lengths" on page 110</a>

**Electrically isolated areas**

See module-specific documentation

**Test voltages (standard values for the 24 V area; for deviations and low-voltage area see module-specific documentation)**

For information about the test voltages between the network and other potential areas, please refer to the documentation for the bus coupler.

Isolating distance	Test voltage
Logic / I/O supply	500 V AC, 50 Hz, 1 min
Logic/functional ground	500 V AC, 50 Hz, 1 min
I/O supply/functional ground	500 V AC, 50 Hz, 1 min

**Approvals**

For the latest approvals, please visit [phoenixcontact.net/products](http://phoenixcontact.net/products).

## 16.2 Ordering data



The complete product catalog is available in electronic form at [phoenixcontact.net/products](http://phoenixcontact.net/products).

### Ordering data for the Axioline F modules

For the ordering data for the Axioline F modules, please refer to the module-specific documentation.

It is also available on the Internet at [phoenixcontact.net/products](http://phoenixcontact.net/products).

### Ordering data for accessories

Description	Type	Order No.	Pcs./Pkt.
<b>Tool</b>			
Screwdriver, slot-headed, VDE-insulated, size: 0.4 x 2.5 x 80 mm, 2-component handle, with non-slip grip	SZS 0,4X2,5 VDE	1205037	1
Crimping pliers, for ferrules without insulating collar according to DIN 46228 Part 1 and ferrules with insulating collar according to DIN 46228 Part 4, 0.25 mm <sup>2</sup> ... 6.0 mm <sup>2</sup> , lateral entry, trapezoidal crimp	CRIMPFOX 6	1212034	1
Crimping pliers, for ferrules without insulating collar according to DIN 46228 Part 1 and ferrules with insulating collar according to DIN 46228 Part 4, 0.25 mm <sup>2</sup> ... 6 mm <sup>2</sup> , lateral entry, trapezoidal crimp	CRIMPFOX 6T	1212037	1
Crimping pliers, for ferrules without insulating collar according to DIN 46228 Part 1 and ferrules with insulating collar according to DIN 46228 Part 4, 0.25 mm <sup>2</sup> ... 6 mm <sup>2</sup> , front entry, trapezoidal crimp	CRIMPFOX 6T-F	1212038	1
Measuring probes	MPS-MT 1-S4-B RD	1982800	50
<b>Marking material (Axioline F modules)</b>			
Zack marker strip for Axioline (device marking), in 2 x 20.3 mm pitch, unprinted, 25-section, for individual marking with B-STIFT 0.8, X-PEN, or CMS-P1-PLOTTER	ZB 20,3 AXL:UNPRINTED	0829579	25
Zack marker strip flat for Axioline (connector/slot marking), in 1 x 5.8 mm + 4 x 10.0 mm pitch, unprinted, 50-section, for individual marking with B-STIFT 0.8, X-PEN, or CMS-P1-PLOTTER	ZBF 10/5,8 AXL:UNPRINTED	0829580	50
Zack marker strip, unprinted: 10-section, for individual marking with B-STIFT, ZB-T or CMS system, enough to mark 100 terminal blocks, for terminal block width of 10.2 mm, color: white	ZB 10:UNBEDRUCKT	1053001	10 strips, each with 10 markers
Zack marker strip, flat, unprinted: 10-section, for individual marking with B-STIFT or ZBF T, for 100 terminal blocks, color: white	ZBF 5:UNBEDRUCKT	0808642	10 strips, each with 10 markers

## Technical data and ordering data

Description	Type	Order No.	Pcs./Pkt.
Insert label, roll, white, unmarked, can be marked with: THERMOMARK ROLL, THERMOMARK ROLL X1, THERMOMARK X, THERMOMARK S1.1, mounting type: snapped into marker carrier, lettering field size: 35 x 28 mm (for H housing)	EMT (35X28)R	0801602	500 individual labels
Insert label, roll, white, unmarked, can be marked with: THERMOMARK ROLL, THERMOMARK ROLL X1, THERMOMARK X, THERMOMARK S1.1, mounting type: snapped into marker carrier, lettering field size: 35 x 46 mm (for F housing)	EMT (35X46)R	0801604	500 individual labels
Insert label, roll, white, unmarked, can be marked with: THERMOMARK ROLL, THERMOMARK ROLL X1, THERMOMARK X, THERMOMARK S1.1, mounting type: snapped into marker carrier, lettering field size: 35 x 18.7 mm (for BK housing)	EMT (35X18,7)R	0801831	500 individual labels
<b>Marking material (Axioline F backplane)</b>			
Markers, 24-section, unmarked, can be marked with THERMOMARK CARD and BLUEMARK, color: white (marking)	UM6M-TM (5X12)	0830928	10
Markers, sheet, white, unmarked, can be marked with: THERMOMARK CARD, THERMOMARK CARD 2.0, THERMOMARK PRIME, BLUEMARK ID, BLUEMARK ID COLOR, TOPMARK LASER, TOPMARK NEO, mounting type: snap into a high marker groove, for terminal block width: 5.2 mm, lettering field size: 4.17 x 11.3 mm (marking)	UCT6M-TM 5	0830756	10
Label, continuous, cassette, transparent with black imprint, mounting type: adhesive, can be marked with THERMO-FOX	MM-TML (EX4,2)R C1 TR/BK	0803979	1
Marker strip, roll, white, unmarked, can be marked with: THERMOMARK ROLL 2.0, THERMOMARK ROLL, THERMOMARK ROLL X1, THERMOMARK ROLLMASTER 300/600, THERMOMARK X1.2, mounting type: adhesive, for terminal block width: 5 mm, lettering field size: continuous x 5 mm	SK 5,0 WH:REEL	0805221	1

## UM EN AXL F SYS INST

Description	Type	Order No.	Pcs./Pkt.
<b>Mounting material</b>			
Patch cable, CAT6, pre-assembled, different lengths	FL CAT6 PATCH ...	See "Interface technology and switching devices" catalog	
<b>Power supplies</b>			
DIN rail, perforated/unperforated, 2 meters (corresponds to TH 35-7.5 according to EN 60715)	QUINT-PS ...	See "Interface technology and switching devices" catalog	
	NS 35/ 7,5 PERF 2000MM	0801733	
	NS 35/ 7,5 UNPERF 2000MM	0801681	
Company Lütze: Mounting strap with low DIN rail, height 7.5 mm, according to DIN EN 50022 Strap width 120 mm Strap width 160 mm	Company Lütze:  SN 120 SN 160	Firma Lütze:  330498 330738	
Standard end bracket, snapped on without tools	CLIPFIX 35-5	3022276	50
End bracket for use in the event of vibrations or installation on vertical DIN rail; to be secured with screws	E/AL-NS 35	1201662	50
Ground terminal block, connection method: screw connection, cross section: 0.2 mm <sup>2</sup> - 4 mm <sup>2</sup> , AWG 24 - 12, width: 5.2 mm, color: green-yellow, mounting type: NS 35/7,5, NS 35/15, NS 32 (can be used as end bracket)	USLKG 2,5 N	0441119	50
Ground terminal block: connection method: screw connection, cross section: 0.2 mm <sup>2</sup> - 6 mm <sup>2</sup> , AWG 24 - 10, width: 6.2 mm, color: green-yellow, mounting type: NS 35/7.5, NS 35/15, NS 32 (can be used as end bracket)	USLKG 5	0441504	50
Connection terminal block, connection method: screw connection, load current: 41 A, cross section: 0.5 mm <sup>2</sup> - 6 mm <sup>2</sup> , width: 7 mm, color: green-yellow	AK G GNYE	0421029	50

## Technical data and ordering data

Description	Type	Order No.	Pcs./Pkt.
<b>Ferrules</b>			
Ferrules with insulating collar (plastic collar), according to DIN 46228-4; sleeve length: 8 mm	Al ...	See "Marking systems, tools, and mounting material" catalog	
Cross section 0.5 mm <sup>2</sup>	Al 0,5 - 8 WH -1000	3200881	1000
Cross section 0.75 mm <sup>2</sup>	Al 0,75- 8 GY -1000	3200894	1000
Cross section 1.0 mm <sup>2</sup>	Al 1 - 8 RD -1000	3200904	1000
Ferrules without insulating collar (plastic collar), according to DIN 46228-1; length: 8 mm	A ...	See "Marking systems, tools, and mounting material" catalog	
Cross section 0.5 mm <sup>2</sup>	A 0,5 - 8	3202481	1000
Cross section 0.75 mm <sup>2</sup>	A 0,75- 8	3202504	1000
Cross section 1.0 mm <sup>2</sup>	A 1 - 8	3202517	1000
Ferrules with insulating collar (plastic collar), according to DIN 46228-4; sleeve length: 10 mm	Al ...	See "Marking systems, tools, and mounting material" catalog	
Cross section 0.5 mm <sup>2</sup>	Al 0,5 -10 WH	3201275	100
Cross section 0.75 mm <sup>2</sup>	Al 0,75-10 GY	3201288	100
Cross section 1.0 mm <sup>2</sup>	Al 1 -10 RD	3200182	100
Cross section 1,5 mm <sup>2</sup>	Al 1,5 -10 BK	3200195	100
Ferrules without insulating collar (plastic collar), according to DIN 46228-1; length: 10 mm	A ...	See "Marking systems, tools, and mounting material" catalog	
Cross section 0.5 mm <sup>2</sup>	A 0,5 -10	3202494	1000
Cross section 0.75 mm <sup>2</sup>	A 0,75-10	3200234	1000
Cross section 1.0 mm <sup>2</sup>	A 1 -10	3200250	1000
Cross section 1,5 mm <sup>2</sup>	A 1,5 -10	3200276	1000

## UM EN AXL F SYS INST

Description	Type	Order No.	Pcs./Pkt.
<b>Material for shield connection</b>		See "Marking systems, tools, and mounting material" catalog	
 Please observe the available space when selecting the shield connection clamps.			
Axioline shield connection set (contains 2 shield bus holders and 2 SK 5 shield clamps)	AXL SHIELD SET	2700518	1
Shield connection clamp for applying the shield on busbars; automatic fixing with spring	SKS ...		
3 mm ... 8 mm diameter	SKS 8	3240210	10
3 mm ... 14 mm diameter	SKS 14	3240211	10
5 mm ... 20 mm diameter	SKS 20	3240212	10
Shield connection clamp for applying the shield on busbars; to be secured with screw	SK ...		
8 mm diameter	SK8	3025163	10
14 mm diameter	SK14	3025176	10
20 mm diameter	SK20	3025189	10
35 mm diameter	SK35	3026463	10
Support bracket (on mounting plate or for busbar)	AB	See "Marking systems, tools, and mounting material" catalog	
Neutral busbar, 10 mm x 3 mm, 1 m long	NLS-CU 3/10 SN 1000 MM	0402174	1
Connection terminal block, connection method: screw connection, load current: 41 A, cross section: 0.5 mm <sup>2</sup> - 6 mm <sup>2</sup> , width: 7 mm, color: silver	AK 4	0404017	50
<b>Cable for connecting PLC relays</b>			
System cable for eight channels	VIP-CAB-FLK14/AXIO/0,14/ ...		
Cable length: 1 m	VIP-CAB-FLK14/AXIO/0,14/1,0M	2901605	
Additional cable lengths	VIP-CAB-FLK14/AXIO/0,14/ ..		
<b>Connecting cable</b>			
Connecting cable, for connecting the controller to a PC for PC Worx, USB A to micro USB B, length: 2 m	CAB-USB A/MICRO USB B/2,0M	2701626	

## Technical data and ordering data

## Ordering data for documentation

Description	Type	Order No.	Pcs./Pkt.
"AxioLine F: diagnostic registers, and error messages" user manual	UM EN AXL F SYS DIAG	-	-



The comprehensive documentation listed above and all module-specific documentation can be downloaded at [phoenixcontact.net/products](http://phoenixcontact.net/products).  
Make sure you always use the latest documentation.

## A Technical appendix: communication objects (PDI objects)

Communication objects are stored on each module. You can access these objects with read, write or read and write services via the PDI channel.

In most cases, the objects are accessed automatically, e.g., when writing the start parameterization during the startup of the bus coupler or the controller.

The objects created in a module are:

- General standard objects (index 0001<sub>hex</sub> to 003D<sub>hex</sub>)  
For more detailed information on these objects, please refer to [Section “General standard objects” on page 137](#).
- Manufacturer-specific application objects (index 0080<sub>hex</sub> to 5FFF<sub>hex</sub>, FF8F<sub>hex</sub>)  
These objects have device-specific variables.  
For more detailed information on these objects, please refer to the documentation for the module.

Table A-1 Object types

Object type	Meaning
Var	Object with only one element (simple variable)
Array	Object with several simple variables of the same data type with the same length
Record	Object with several simple variables of different data types or the same data type with different lengths

Table A-2 Data types

Data type	Meaning
Visible string	Byte string only with printable ASCII characters The byte string finishes with 00 <sub>hex</sub> (null-terminated) or is filled with 00 <sub>hex</sub> to reach the total length. <div style="border: 1px solid black; padding: 5px; margin-top: 10px;">  In the following tables and the module-specific data sheets, only the pure user data is provided in the “Content” column. Null termination and filling up a visible string with 00<sub>hex</sub> is not shown.           </div>
Bit string	Bit strings always have a length of $n \times 8$ bits, where $n \in \mathbb{N}$ ( $n$ element of the natural numbers).
Octet string	Byte string with any contents
Unsigned 8	UINT8 Value without sign, only positive values 00 <sub>hex</sub> ... FF <sub>hex</sub>
Unsigned 16	UINT16 Value without sign, only positive values 0000 <sub>hex</sub> ... FFFF <sub>hex</sub>
Unsigned 32	UINT32 Value without sign, only positive values 0000 0000 <sub>hex</sub> ... FFFF FFFF <sub>hex</sub>

The following applies for the tables below:

Table A-3 Key for the following tables

Abbreviation	Meaning
N	Number of elements
L [bytes]	Length of the element in bytes
R	Read
W	Write

## A 1 General standard objects

The standard objects include:

- Objects for identification (device rating plate)
- Objects for device diagnostics
- Objects for process data management
- Objects for device management
- Object with object descriptions
- Objects for modular devices and subsystems

### A 1.1 Objects for identification

These objects describe the manufacturer, the device, and device application and form the device rating plate

The bold entries in [Table A-4](#) are identical for all Axioline F modules and Axioline Smart Elements from Phoenix Contact. All other entries may vary depending on the individual module.

Table A-4 Objects for identification (device rating plate) according to basic profile V3.0

Index [hex]	Object name	Data type	N	L [bytes]	Rights	Meaning	Content/example
<b>Manufacturer</b>							
0001	VendorName	Visible string	1	32	R	Manufacturer name	<b>PHOENIX CONTACT</b>
0002	VendorID	Visible string	1	7	R	Manufacturer ID	<b>00A045</b>
0003	VendorText	Visible string	1	58	R	Manufacturer text	<b>Components and systems for industrial automation</b>
0012	VendorURL	Visible string	1	58	R	Manufacturer URL	<b>www.phoenixcontact.net/qr/&lt;Order No.&gt;</b>

## UM EN AXL F SYS INST

Table A-4 Objects for identification (device rating plate) according to basic profile V3.0 [...]

Index [hex]	Object name	Data type	N	L [bytes]	Rights	Meaning	Content/example
<b>Module - general</b>							
0004	DeviceFamily	Visible string	1	58	R	Device family	... (e.g., I/O analog IN)
0006	Product family	Visible string	1	32	R	Product family	<b>AXL F, AXL F XC or AXL SE</b>
000E	CommProfile	Visible string	1	5	R	Communication profile	633
000F	DeviceProfile	Visible string	1	5	R	Device profile	0010
0011	ProfileVersion	Record	2		R	Profile version	
.1	BuildDate	Visible string	1	11	R	Version date	2018-04-19
.2	Version	Visible string	1	19	R	Version ID	Basic profile V3.0
0017	Language	Record	2	6; 50, max.	R/W	Language	<b>en-us; English</b>
<b>Module - specific (for a specific module)</b>							
0005	Capabilities	Array of octet strings	N	N * 8	R	Device properties	... (e.g., Nothing) See <a href="#">Table A-5</a>
0007	ProductName	Visible string	1	32	R	Product name	... (e.g., AXL F AI4 I 1H, AXL SE AI4 I 4-20)
0008	SerialNo	Visible string	1	22	R	Serial number	xxxxxxxxxx (e.g., 12345123456)
0009	ProductText	Visible string	1	58	R	Product text	... (e.g., 4 analog input channels)
000 A	OrderNumber	Visible string	1	32	R	Order No.	xxxxxxx (e.g., 2688491)
000B	Hardware version	Record	2		R	Hardware version	
.1	BuildDate	Visible string	1	11	R	Manufacturing date	YYYY-MM-DD
.2	Version	Visible string	1	11	R	Version ID	xxx (e.g., 01)
000C	FirmwareVersion	Record	2		R	Firmware version	
.1	BuildDate	Visible string	1	11	R	Manufacturing date	YYYY-MM-DD
.2	Version	Visible string	1	11	R	Version ID	xxx (e.g., --, 1.10)
000D	PChVersion	Record	2		R	Parameter channel version	
.1	BuildDate	Visible string	1	11	R	Manufacturing date	YYYY-MM-DD
.2	Version	Visible string	1	11	R	Version ID	xxx (e.g., 2016-12-01, PDI V1.10)
0037	DeviceType	Octet string	1	8	R	Device type	xx xx xx xx xx xx xx xx <sub>hex</sub> (e.g., 00 20 00 08 00 00 00 A6 <sub>hex</sub> )

## General standard objects

Table A-4 Objects for identification (device rating plate) according to basic profile V3.0 [...]

Index [hex]	Object name	Data type	N	L [bytes]	Rights	Meaning	Content/example
003 A	VersionCount	Array of UINT16	4	8	R	Version counter; unique consecutive numbering for the version of the corresponding component	E.g., 0009 0002 0001 0117
.1	ProfileVersion	Unsigned 16	1	2	R	0009 for basic profile V3.0	xx xx <sub>hex</sub> (e.g., 0009)
.2	PChVersion	Unsigned 16	1	2		PDI version	xx xx <sub>hex</sub> (e.g., 0002)
.3	Hardware version	Unsigned 16	1	2		Hardware version e.g., HW 01	xx xx <sub>hex</sub> (e.g., 0001)
.4	Firmware version	Unsigned 16	1	2		Firmware version e.g., FW 1.17	xx xx <sub>hex</sub> (e.g., 0117)
<b>Use of the device</b>							
0014	Location	Visible string	1	58	R/W	Installation location	... (e.g., Please fill in ... ); Can be filled in by the user.
0015	Equipment Ident	Visible string	1	58	R/W	Equipment ID	... (e.g., Please fill in ... ); Can be filled in by the user.
0016	ApplDevice Addr	Unsigned 16	1	2	R/W	Application-specific device address	... (e.g., Please fill in ... ); Can be filled in by the user.

**Properties (0005<sub>hex</sub>: Capabilities)**

This object indicates the properties and functions the device has in addition to the basic functions. At the moment, the following properties exist:

Table A-5 Properties

Content	Meaning
Nothing	No additional functions
Safety0	The slave supports secure data communication. This takes place in both directions.
Energy0	The slave supports energy management.
SubMA_0	The slave is a subbus master. There is at least one additional subsystem below this slave.
FwUpdt0	The slave supports the firmware update. Currently, only the Phoenix Contact Service can perform a firmware update.
SyncI_0	The slave supports synchronization of the inputs.
SyncO_0	The slave supports synchronization of the outputs.

## UM EN AXL F SYS INST

## A 1.2 Objects for diagnostics

These objects describe the diagnostic state of the device and any connected I/O devices, as well as options for resetting diagnostics.

For the specific content of these objects, please refer to the module-specific data sheet.

### A 1.2.1 Diagnostic state (0018<sub>hex</sub>: DiagState)

Table A-6 Objects for diagnostics: diagnostic state (read) **according to basic profile V2.x**

Index [hex]	Object name	Data type	N	L [bytes]	Meaning
0018	DiagState	Record	6		Diagnostic state
.1	Lfd.Nr.	Unsigned 16	1	2	Consecutive error number since the last reset or error memory reset
.2	Priority	Unsigned 8	1	1	Priority of the message. 1: highest priority
.3	Channel/ Group/Module	Unsigned 8	1	1	Channel, group or module where the error occurred FF <sub>hex</sub> : entire device
.4	Code	Octet string	1	2	Error code
.5	MoreFollows	Bit string 8	1	1	Additional information on malfunction; not used with AxioLine F up to now
.6	Text	Visible string	1	51, max.	Plain text message. Default: status OK

Table A-7 Objects for diagnostics: diagnostic state (read) **according to basic profile V3.x**

Index [hex]	Object name	Data type	N	L [bytes]	Meaning
0018	DiagState		11	23 + 100, max.	Diagnostic state
.01	Lfd.Nr.	Unsigned 16	1	2	Consecutive number Consecutive error number since the last power up or error memory reset
.02	Priority	Unsigned 8	1	1	Priority of the message. 1: highest priority
.03	Channel	Unsigned 8	1	1	Channel on which the error occurred FF <sub>hex</sub> : entire device
.04	Code	Octet string	1	2	Error code
.05	MoreFollows	Bit string 8	1	1	Additional information Information for interpreting the following data (see <a href="#">Table A-8</a> )
.06	Reserved	Octet string	1	2	Reserved (= 0000 <sub>hex</sub> )

## General standard objects

Table A-7 Objects for diagnostics: diagnostic state (read) **according to basic profile V3.x [...]**

Index [hex]	Object name	Data type	N	L [bytes]	Meaning
.07	SubModNo	Unsigned 8	1	1	Submodule number If the device is a modular device, the corresponding sub-module is specified here. If the device is not a modular device, "0" is entered here.
.08	FunctionGroup	Octet string	1	8	Function group Short designation of the function of the group in which the diagnostics were triggered. E. g.: DI (0x44, 0x49, 0x00, 0x00, 0x00, 0x00, 0x00, 0x00) RTD (0x52, 0x54, 0x44, 0x00, 0x00, 0x00, 0x00, 0x00) AI, AO, DO, IOL, CNT, INC, RS485, PSDI, PSDO, SC The permissible function groups are listed in objects 0x003B.1 and 0x003C.1. The manufacturer-specific designation (e.g., "Relay OUT") is specified in the diagnostic text (0x0018.11).
.09	AddValue	Octet string	1	4	Additional information "Additional value" regarding the current diagnostic state of the device.
.0A	TextLength	Unsigned 8	1	1	Text length Length of the following diagnostic text in bytes.
.0B	Text	Visible string	1	100, max.	Diagnostic text Device-specific explanation of the malfunction that occurred. Information includes: – Type of the error – Function group or channel – Terminal point – Option for action for the user Default: "Status OK" The string is terminated 00 <sub>hex</sub> .

Table A-8 Index 5: additional information

Byte/bit	Value	Meaning
Byte	00 <sub>hex</sub>	No additional information
Bit 0 ... 6	0	Reserved
Bit 7	1	Indication that this is an extended version of object 0018 <sub>hex</sub> (compared to version V2.x).

## UM EN AXL F SYS INST

A 1.2.2 Acknowledge diagnostic messages (0019<sub>hex</sub>: ResetDiag)

Table A-9 Objects for diagnostics: acknowledge diagnostic messages (write)

Index [hex]	Object name	Data type	N	L [bytes]	Meaning
0019	ResetDiag	Unsigned 8	1	1	Acknowledge diagnostics messages Deletes the corresponding diagnostic memory and acknowledges the message

Table A-10 Value range

Value (hex)	Meaning
00	Permit all diagnostic messages
02	Delete and acknowledge all diagnostic messages that are still pending
05	Delete and acknowledge the last (pending) diagnostic message  Used with safety devices as follows:  If an error is no longer present when this value (05 <sub>hex</sub> ) is written, any "passivated" output is only now released again and also can only now be set again.
06	Delete and acknowledge all diagnostic messages and do not permit new diagnostic messages

## A 1.3 Objects for process data management

The contents for objects implemented on a device are contained in the module-specific documentation.

Table A-11 Objects for process data management

Index [hex]	Object name	Data type	N	L [bytes]	Rights	Meaning
0024	ResetCode	Array of UINT16	N	N * 2	R/W	Substitute value behavior during bus reset (PDOOUT)
0025	PDIN	OctetString	1	Process data length	R	Input process data
0026	PDOOUT	OctetString	1	Process data length	R	Output process data
002F	PDOOUT_Subst	OctetString	1	Process data length	R/W	Substitute value for output process data If acceptance of substitute value has been parameterized in 0024 <sub>hex</sub> .
0030	PF_Code	Array of UINT16	N	N * 2	R/W	Substitute value behavior during I/O error (PDIN)
0031	PDIN_Subst	OctetString	1	Process data length	R/W	Substitute value for input process data If acceptance of substitute value has been parameterized in 0030 <sub>hex</sub> .

## A 1.4 Objects for device management

Table A-12 Objects for device management (write)

Index [hex]	Object name	Data type	N	L [bytes]	Rights	Meaning	
0029	ParamSet WriteControl	UINT8	1	1	R/W	Block parameterization control, see <a href="#">“Block parameterization” on page 144</a>	
						01	Initiate block parameterization
						00	Terminate block parameterization
						Other	Reserved
002A	Conflict Dictionary	Array of records (N * 6 elements)	N	N * 8	R	Conflict dictionary. Result of block parameterization n = 1 ... N, N = number of dependent parameters, see <a href="#">“Conflict dictionary” on page 145</a>	
.01	ConfGrNo_n	UINT8	1	1	R	Conflict group number of the nth dependent parameter	
.02	Subslot_n	UINT8	1	1	R	Subslot of the nth dependent parameter	
.03	Index_n	UINT16	1	2	R	Index of the nth dependent parameter	
.04	Subindex_n	UINT8	1	1	R	Subindex of the nth dependent parameter	
.05	Element_n	UINT8	1	1	R	Element in the record of the nth dependent parameter	
.06	AddCode_n	UINT16	1	2	R	Additional information on the nth dependent parameter	
002B	ParamSet	UINT16	1	2	R/W	Select parameter record	
002D	ResetParam	UINT8	1	1	R/W	Reset parameterization	
						00	No action
						01	Reset application parameters to default values (application objects and selected standard objects)
						Other	Reserved
002E	ParamHash	UINT32	1	4	R	Hash value, see <a href="#">“Hash value” on page 145</a>	
0040	ListOfObj ToRestore	Array of Records	N	N * 3	R	List of objects to be restored  List of objects to be read and backed up from this device in order to restore the parameterization for the substitute device in the event of a device being replaced.	
0048	PChMaxResp Time	UINT16	1	2	R	Maximum permissible PDI response time in ms Default: 01F4 <sub>hex</sub> (500 ms)	

**A 1.4.1 Block parameterization**

Block parameterization serves to enable the joint transfer of interdependent parameters. If you attempt to parameterize dependent parameters individually, this may result in the error message "Dependency of other parameter not taken into consideration". Block parameterization should be used in this case.

The plausibility check for the parameterization data is disabled during block parameterization, the data is only stored temporarily. However, the data length and subindex are checked.

The plausibility check is only performed when block parameterization is terminated with data item 00<sub>hex</sub>.

If the check was completed with no errors, the temporarily stored parameterization data is applied and stored in the flash memory.

If errors were detected in the temporarily stored parameterization data, the service is acknowledged negatively with 08, 00, 0040<sub>hex</sub>.

The exact cause of the error can be read in object 002A<sub>hex</sub>. The error codes are indicated by object 0080<sub>hex</sub>.

Not all startup objects have to be written.

The following actions are carried out when the parameter contents are modified:

**Write control changes from 00<sub>hex</sub> to 01<sub>hex</sub>:  
initiation of block parameterization**

- Block parameterization is initiated
- Conflict dictionary is reset

**Write control changes from 01<sub>hex</sub> to 00<sub>hex</sub>:  
termination of block parameterization**

- Block parameterization is terminated
- Individual parameterization is active
- Parameterization is checked for compatibility

Parameters are compatible:

- The parameter contents are accepted.
- Write access to the write control parameter is acknowledged positively.

Parameters are not compatible:

- The old contents of all the parameters required for block parameterization remain in effect.
- The conflict dictionary is updated.
- Write access to the write control parameter is acknowledged negatively.

Error code in the event of negative acknowledgment:

Code (hex)	Additional code (hex)	Meaning	Remedy
0801	0040	Dependent values were not taken into consideration.	Check the parameterization.

In the event of an error, the conflict dictionary contains the indices and additional code for the parameters involved in the conflict.



The block parameterization is permanently stored in the device description files for the module. This means that whenever the module is parameterized using a tool, the block parameterization is automatically launched at the start of parameterization and terminated at the end of parameterization.

To use block parameterization without tools, proceed in the following sequence:

- Initiate block parameterization by writing the value 01<sub>hex</sub> to object 0029<sub>hex</sub>.
- Write the startup parameters that you want to change to the corresponding objects.
- Terminate block parameterization by writing the value 00<sub>hex</sub> to object 0029<sub>hex</sub>.

#### A 1.4.2 Conflict dictionary

The conflict dictionary contains the indices and error messages (additional code) for the parameters involved in the conflict.

##### Block parameterization

With block parameterization, all conflicts within the “parameter block” are listed.

If, after the block parameterization has been completed, you receive a negative response, the plausibility of the parameters has been violated. In this case, the module does not save the parameterized values.

Check and correct the parameterization.

##### Individual parameterization

With individual parameterization, the contents of the conflict dictionary refer to the “last” write access.

Check and correct the parameterization.

#### A 1.4.3 Hash value

The hash value is a unique value that is generated for a specific device and which ensures the integrity of the parameter data. The data of the startup objects is verified with this hash value. The value changes only if an object relevant for startup has been changed. The value is therefore suitable for comparing the parameterization.

## UM EN AXL F SYS INST

**A 1.5 Objects for object descriptions**

These objects are only applicable to tools.

Table A-13 Object descriptions

Index [hex]	Object name	Data type	N	L [bytes]	Rights	Meaning
0038	ObjDescrReq	Record	2	3	R/W	Object description request
0039	ObjDescr	Record	16	58, max.	R	Object description

**A 1.6 Objects for energy management**

Table A-14 Objects for energy management

Index [hex]	Object name	Data type	N	L [bytes]	Rights	Meaning
003D	WakeUpTime	UINT16	1	2	R	Startup time, the period of time (in ms) that elapses between the point at which the supply voltage is switched on, and the time when the system is ready to operate Default: 01F4 <sub>hex</sub> : < 500 ms

**A 1.7 Objects for modular devices**

The contents for objects implemented on a device are contained in the module-specific documentation.

Table A-15 Objects for modular devices

Index [hex]	Object name	Data type	N	L [bytes]	Rights	Meaning
0035	SubBusInfo	Record	1	16	R	Subbus information
0036	ActSubBusStructure	Array of Records	N	N * 8	R	Actual subbus configuration
0041	RefSubBusStructure	Array of Records	N	N * 8	R/W	Desired subbus configuration
0042	ModuleStatus	Array of bytes	N	N * 1	R	Module status
0043	SubBusBehaviour	Record	1	3	R/W	Subbus behavior
0044	SubBusControl	UINT8	1	1	R/W	Subbus control
0047	AddInfo	Record	1	16	R	Additional information
00F0	PackedPrm	Record	1	63, max.	R/W	All startup parameters consecutively; only relevant for PROFIBUS
C000 ... C07F	ProjBasProf					Projection of basic profile onto the subbus modules

## A 2 Manufacturer-specific application objects

Manufacturer-specific application objects are module-specific and are documented in the module-specific documentation.

For example, parameterization of individual channels for analog modules or parameterization of filter times for digital input modules is implemented using these objects.

## A 3 Value ranges

Make sure to observe the permissible value ranges during module parameterization. If invalid values are specified for an object, these are not saved and an error message is generated.

## A 4 Function blocks for access to the objects under PC Worx

Under PC Worx, you can access the PDI objects via function blocks that are stored in the axl\_pdi\_vx\_yy library. The library can be downloaded at [phoenixcontact.net/products](http://phoenixcontact.net/products).

To install the library under PC Worx, select the pc\_worx\_6\_x\_AXL\_PDI\_x\_yy.exe file in the download area of an Axioline F bus coupler.

Detailed documentation is provided as online help for each of the function blocks.

When you access an object that is not implemented, you will receive a corresponding error message.

## B Technical appendix: Altitude, times, synchronization, substitute value behavior, and power-on behavior

### B 1 Use of Axioline F modules at an elevation of more than 3000 meters

This section applies to modules of the Axioline F product group that are operated with a DC voltage of <60 V DC.



**WARNING: Dangerous contact voltage. Loss of safety function.**

This section does **not** apply to the following modules or applications:

- Modules that are not operated with PELV (protective extra-low voltage) (e.g., 120 V or 230 V)
- Modules with safety functions (e.g., SafetyBridge, PROFIsafe)
- Use of a safe signal path
- Use in potentially explosive areas (IEC Ex, ATEX, hazardous location).
- XC versions

In these cases, consider the individual module or application separately.

The Axioline F modules are approved for use up to an elevation of 3000 m above sea level, see [“Technical data” on page 125](#).

The maximum permissible ambient temperature decreases at elevations above this level. Therefore, keep temperature derating in mind when using the modules at an elevation of more than 3000 m up to 5000 m.

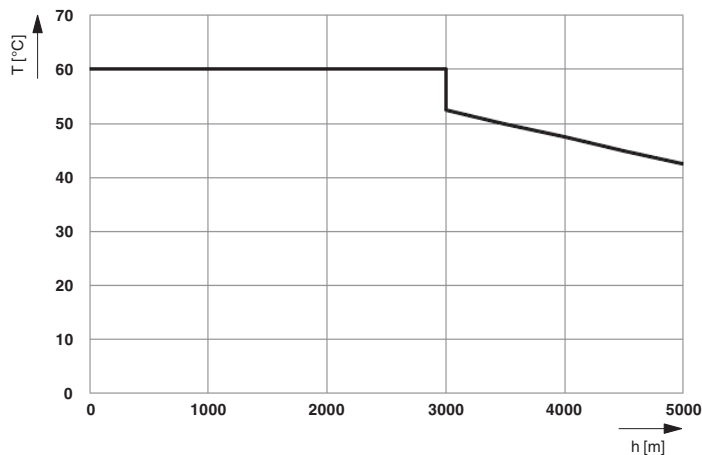

Figure B-1 Derating of the permissible ambient temperature depending on the operating elevation

Key:

T [°C]	Maximum ambient temperature (operation) in °C
h [m]	Elevation in m

## B 2 Transmission speed

Within an Axioline F station, communication takes place via a fast, cyclic and time-equidistant local bus. The typical cycle time is less than 50  $\mu\text{s}$ .

## B 3 Typical cycle time on the local bus

The typical cycle time on the local bus is calculated according to the following equation:

$$t = 2 \mu\text{s} + n * 1 \mu\text{s}$$

Where:

t Typical cycle time on the local bus

n Number of modules connected to the bus coupler

The typical cycle time for a station comprising five modules is:

$$t = 2 \mu\text{s} + n * 1 \mu\text{s}$$

$$t = 2 \mu\text{s} + 5 * 1 \mu\text{s}$$

$$t = 7 \mu\text{s}$$

## B 4 Response times for an Axioline F system

In general, the response time for an I/O system is the time from reading in the input, processing in the controller to setting the output.

This includes:

- The time for copying in the bus heads (bus coupler or controller; 1 in Figure B-2)
- The cycle time of the local bus (2)
- The conversion time in the I/O modules (3)
- The update time of the I/O modules (4)
- The update time of the higher-level network (5)
- The processing time (cycle time) in the controller (6)

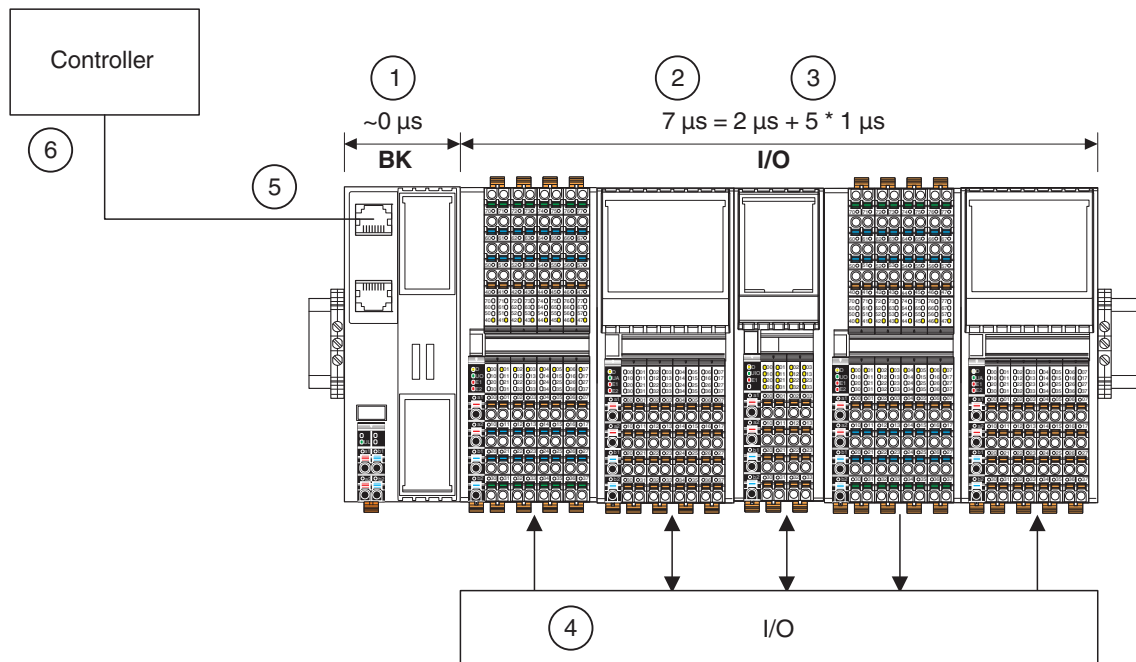

Figure B-2 Response times of the overall system

## Response times for an Axioline F system

Typical processing times for an Axioline F system:

Table B-1 Typical processing times in the overall system (example)

<b>1</b>	Time for copying in the Axioline F bus head	~ 0 $\mu$ s
<b>2</b>	Cycle time of the Axioline F local bus	Here: 7 $\mu$ s
<b>3</b>	Conversion time in the Axioline F I/O modules (depends on the I/O application)	E.g., 100 $\mu$ s, 10 $\mu$ s, 1 $\mu$ s here: 1 $\mu$ s per module
<b>4</b>	The I/O update time	E.g., <100 $\mu$ s
<b>5</b>	Cycle time of the higher-level network (depends on the higher-level network)	E.g., PROFINET IRT with 250 $\mu$ s
<b>6</b>	Controller cycle time	1 ms

The example clearly shows that when determining the response time of the overall system, Axioline F represents the smallest proportion by far and therefore can normally be ignored.

### Explanation of terms

Conversion time	Signal runtime of the Axio protocol in an Axioline F module
Input filter time (e.g., RTD)	Part of the update time
Update time (DI, DO)	Signal runtime between the I/O and the protocol chip in the I/O module

## B 5 Synchronization



If you want to use the synchronization function, make sure that the following requirements are met simultaneously:

- The bus coupler or controller supports the function.
- There is at least one module in the Axioline F station that supports local bus synchronization.

Only the Axioline F modules that support local bus synchronization can be operated in a synchronous manner. All the other Axioline F modules of the station work in an asynchronous manner.

### B 5.1 Synchronization in general

Some Axioline F modules offer a synchronization option.

To use this property, synchronization must be consistently supported from the clock master in the higher-level network to the I/O modules.

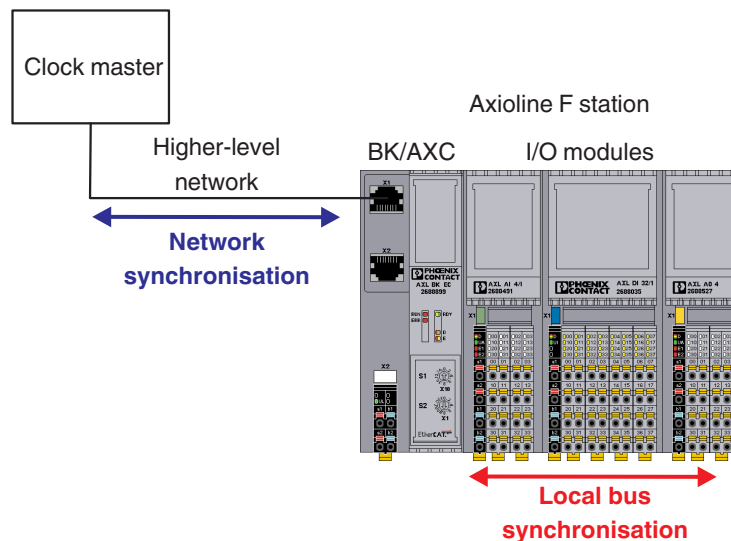

Figure B-3 Network and local bus synchronization

#### Clock master

In the overall system, the clock master is the unit which determines the synchronization times and synchronization time points and sends out a synchronization clock signal. Usually, this is the network controller.

#### Higher-level network

The higher-level network is the communication system which links the controller and the head of the Axioline F station. This network must support synchronization.

The head of an Axioline F station can be a bus coupler or an AXC controller. Currently, only some bus couplers support synchronization.

**Bus couplers**

The bus coupler is the link between the higher-level network and the Axioline F station. It must support synchronization according to the definition of the higher-level network and transfer the synchronization parameters and signals to the Axioline F station.

**Examples of bus couplers which support the synchronization mechanisms for a network**

Table B-2 Synchronization mechanisms of the bus couplers

Network	Bus coupler	Synchronization mechanism of the network	Remark
EtherCAT®	AXL F BK EC	SM-synchronous	Asynchronous
		DC-synchronous	The bus cycle of the local bus is synchronized with the EtherCAT® cycle. The implemented distributed clock unit is used to synchronize the processes in a temporal manner.
Sercos	AXL F BK S3	Asynchronous	Asynchronous
		Clock-synchronous	Cyclical master-slave communication with a cycle time to be selected during initialization.

**I/O modules**

Not all I/O modules support local bus synchronization.

In the case of modules which support local bus synchronization, the SyncI\_0 (synchronization of inputs) property or SyncO\_0 (synchronization of outputs) property is specified in the "Capabilities" object 0005<sub>hex</sub>.

In the case of an I/O module which works asynchronously, its input or output signals are read or output at a time point determined by the higher-level network. The data is consistent, i.e., all data for a module is processed at the same time point.

In order for the clock master in the higher-level network to calculate the exact time point for an input or output, the module provides the bus coupler or Axiocontrol with various information. This includes, for example, the minimum possible repeat time, signal processing length, and required run-up for the transfer of the data. These values are either permanently set in the module or are dynamically determined based on the parameterization.

The bus coupler or Axiocontrol reads the values and makes them available to the clock master. The synchronization time point determined by the clock master, which can be different for each module, is set by the bus coupler or Axiocontrol in each module that can be synchronized.

In this way, synchronism requirements within a station of a few nanoseconds are achieved. The precision of the overall system is essentially determined by the higher-level network capabilities and its clock master.

Modules that do not support synchronous processing do not affect a synchronous system. They do not accept or transfer the values at a specific point in time but as fast as possible.

## B 5.2 Synchronization options

Modules can either support synchronization or not. When a module can be synchronized, you can use the function or deactivate it, depending on the application.

Table B-3 Synchronization options

Module property	Use	Remark
Cannot be synchronized	Asynchronous	
Can be synchronized	Asynchronous	If synchronization is not required for your application or is not useful, then deactivate synchronous mode.
	Synchronous	The modules are to be synchronized. Select the modules in a suitable manner. Parameterize them accordingly. See <a href="#">Section B 5.3, "Conditions for local bus synchronization"</a> .

## B 5.3 Conditions for local bus synchronization

To make good use of this function, the following conditions must be met:

1. The higher-level controller must support synchronization mechanisms for the network.
2. The bus coupler must support synchronization mechanisms for the network.
3. At least one module on the local bus must support local bus synchronization.

## B 6 Substitute value behavior and power-on behavior

### Substitute values for Axioline F

The term substitute value is used for the behavior when switching on the power supply as well as for the behavior when valid process data is missing.

#### Power-on behavior

The power-on behavior defines the module behavior after switching on the power supply. An Axioline F module has this behavior until it receives valid process data.

#### Substitute value behavior (failsafe behavior)

The substitute value behavior defines the module behavior when valid process data is missing.

Once a module has exchanged valid process data for the first time after switching on the power supply, the substitute value behavior is activated.

If valid process data is missing (e.g., in the event the connection is aborted), the module changes to the substitute value behavior.

Typically, the substitute value behavior is parameterized using the engineering tool or object 0024<sub>hex</sub> "Substitute value behavior when process data is missing". The following values are possible:

Table B-4 Possible settings for the substitute value behavior

Code (hex)	Behavior	Example: AXL F AO4 1H
0000	Output of zero values	Output of zero values (0 V / 0 mA / 4 mA) at the output
0001	Output of final values	Output of final values (10 V / 5 V / 20 mA) at the output
0002	Hold last value	Hold last value
0003	Substitute value	Acceptance of substitute values from the "Substitute OUT process data" object (002F <sub>hex</sub> )



To determine whether, and if yes, which substitute value behavior can be parameterized for a module, please refer to the module-specific data sheet.

## C Index

### Numerics

1-wire technology .....	76
2-wire technology .....	77
3-wire technology .....	77
4-wire technology .....	78

### A

Application note .....	11
Application objects .....	147
Approvals	
Approval of a product .....	19
Product with specific approval .....	20
Array .....	136
Axioline F backplane .....	97
Housing versions .....	97
Indication elements .....	101
Slots .....	101
Axioline F local bus .....	15, 17

### B

Backplane	
see Axioline F backplane .....	97
Bit string .....	136
Block parameterization .....	143, 144
Bus base module .....	25
Design .....	33
Bus connection .....	16
Bus coupler .....	24
Design .....	32
Diagnostics .....	92
Indicators .....	92
Nominal dimensions .....	34
Supply .....	70

### C

Cable connection method .....	129
Cable cross section .....	129
Checking the delivery .....	45
Communication objects .....	136, 151
Standard objects .....	137
Components .....	15
Conductor cross sections .....	63, 110

Conflict dictionary .....	143, 145
Connecting cables	
Shielded .....	67
Unshielded .....	66
Connecting shielded cables .....	67
Connecting the network .....	72
Connecting unshielded cables .....	66
Connection	
FE .....	17
I/O .....	17
Network .....	72
Supply voltage .....	17
Connection technology .....	74
1-wire technology .....	76
2-wire technology .....	77
3-wire technology .....	77
4-wire technology .....	78
Connector	
Inserting .....	59
Removing .....	59
Connectors .....	17
Control box .....	16, 50
See also Junction box	
Control cabinet .....	16, 50
Controller .....	23
Design .....	30, 98
Indicators .....	91
Nominal dimensions .....	34, 99, 100
Cycle time .....	149

### D

Data sheet .....	11
Data transfer .....	128
Data type .....	136
Design .....	30, 98
Bus base module .....	33
Bus coupler .....	32
Controller .....	30, 98
Input/output modules .....	33
Device rating plate .....	137
Device replacement .....	123

Diagnostics .....	18, 91	IP20 degree of protection.....	50
Bus coupler .....	92	<b>J</b>	
Extended .....	91	Junction box.....	16, 50
I/O modules .....	94	<b>L</b>	
Dimensions		LED	
Input/output modules.....	35, 37	I/O connector.....	96
DIN rail .....	50	Power connector .....	94
Disposal .....	124	Local bus	
Downloads .....	12	See Axioline F local bus .....	15
<b>E</b>		Low voltage.....	16
End bracket.....	51	<b>M</b>	
Error		Maintenance .....	123, 124
Diagnostics.....	91, 117	Manufacturer-specific application objects .....	147
<b>F</b>		Marking material .....	102
FE connection .....	17	Mechanical requirements.....	126
Function blocks .....	137	Modules	
Functional ground (FE) .....	82	Maximum number .....	52
<b>G</b>		Mounting .....	53
Generate product PDF .....	11	Order .....	52
Grounding		Removing.....	56
Functional grounding.....	82	Mounting.....	16, 53
Grounding concept.....	82	Distances .....	60
<b>I</b>		Location .....	16, 50
I/O		Mounting position.....	51
Connection.....	17	<b>N</b>	
I/O modules		Nominal dimensions	
Diagnostics.....	94	Bus coupler .....	34
Indicators.....	94	Controller.....	34, 99, 100
Indication elements		Input/output modules.....	35, 36, 37, 101
Axioline F backplane .....	101	Number of modules.....	52
Indicators		<b>O</b>	
Bus coupler .....	92	Object type.....	136
Controller.....	91	Octet string .....	136
I/O modules .....	94	Order.....	52
Input modules .....	25	Order designation .....	21
Input/output modules .....	25	Output modules .....	25
Design .....	33	<b>P</b>	
Nominal dimensions.....	35, 36, 37, 101	Packing slip.....	10
Supply .....	71	Parameterization memory .....	18
Intended use .....	19		
IP20.....	16, 50		

**UM EN AXL F SYS INST**

PCP objects	
Application objects .....	147
PDI channel.....	119, 121, 136, 151
Power module	
Supply .....	70
Power supply	
Requirement.....	70
Sizing .....	70
Product description .....	15
Product groups.....	21
Programming interface.....	17, 30
Protective extra-low voltage .....	16
Protective ground (PE).....	84
Push-in.....	66

**Q**

Quick start guide .....	11
-------------------------	----

**R**

Reaktionszeit .....	159
Record .....	136
Removal.....	16, 56
Replacing .....	123
Reset button.....	18
Response time .....	150

**S**

Scope of supply .....	45
Service interface .....	17, 32
Shielding .....	84
Analog sensors and actuators .....	84
Concept.....	84
Connecting the shield.....	67
Slots for Axioline F backplane .....	101
Spring lever .....	41, 43, 65
Standard objects .....	137
Diagnostics.....	140
Startup+ .....	17
Status.....	91
Storage .....	45
Stripping lengths .....	64, 111
Supply	
Bus coupler .....	70
Input/output modules.....	71
Power module .....	70

Supply voltage	
Connection.....	17
System data .....	125

**T**

Test voltages .....	129
Tool.....	52
Touch connection .....	41, 65
Transmission speed.....	149
Transport .....	45
TWIN ferrules.....	64, 111

**U**

Unpacking.....	45
Unsigned 16.....	136
Unsigned 32.....	136
Unsigned 8.....	136
User manual.....	10

**V**

Var .....	136
Versions.....	15
Visible string.....	136
Voltage ranges	
Low voltage .....	18
Protective extra-low voltage .....	18

**W**

Web-based management .....	17
----------------------------	----

## D Revision history

Table D-1 Revision history

Revision	Date	Contents	
00	2010-02-16	First publication	
01	2011-08-22	Entire document Corrections Addition: new modules, housings, connectors	
02	2011-09-08	Entire document Corrected terminology (Push-in technology)	
03	2013-12-19	Entire document Complete revision Change: Axioline -> Axioline F Change: Axio bus -> Axioline F local bus Addition: new modules, housings, connectors Addition: AWG	
		Section 1.2 Documentation on the Internet Correction	
		Section 4.4 Color and marking Addition: colors, function identification, marking	
		Section 5.4 Reporting diagnostics via PDI New: reporting diagnostics via PDI	
		Section 6.1 Basic information about mounting Addition: Warning "NOTE: Disregarding this warning may result in malfunction" Revision: mounting position Revision: maximum number of modules	
			Section 6.3 Mounting/removal Addition: F-BK bus coupler housing
			Section 9 Technical data and ordering data Corrections/additions
		Appendix A3 Response times for an Axioline F system Revision	
		Appendix A 5 Communication objects Addition: visible string	
		Appendix A 5.2 General standard objects Corrections/additions	
Appendix A 6 Synchronization New			
04	2015-05-22	Entire document Complete revision of all sections Additions – New modules, housings, connectors – Low voltage area – Safety notes	
05	2015-06-18	Entire document Corrections	

## UM EN AXL F SYS INST

Table D-1 Revision history

Revision	Date	Contents		
06	2017-02-15	Section 6.2	Stripping lengths/insertion lengths	Warning: recommendation for crimping
		Section 8	Diagnostic and status indicators	Addition: notes
		Section 8.3.1	LEDs on the power connectors	Correction for LEDs E1 and E2
		Appendix A	Technical appendix	New: A1 Use of Axioline F modules at an elevation of more than 3000 meters
		Entire document		
07	2018-11-22	Section 4.1	Structure of the order designations	Addition: new functions
		Section 4.6	Master	New
		Section 5.1	Housing versions	Addition: housings AXC F 2xxx and 1F (PM)
		Section 5.2.2	AXC F controller	New
		Section 5.3.1	AXC F controller	New
		Section 5.3.4	Power measurement module	New
		Section 6.4	Mounting and removing modules, left alignment	New
		Section 7.2	Conductor cross sections, and stripping and insertion lengths	Addition: text in warning "NOTE: Malfunction when the conductor is not securely fixed"
		Section 7.10.5	Redundant signals	Addition: redundant digital outputs
		Section 9.2	Indicators on bus couplers	Addition: for D LED, flashing yellow/red
		Section 10.3	Saving parameters	Revision
		Section 11	Software support	Revision
		Appendix A4	Response times for an Axioline F system	Revision
		Appendix A5	Communication objects (PDI objects)	Addition
		Appendix A 5.2	General standard objects	Conversion to basic profile V3.0
		Appendix A6	Synchronization	Addition: note
		Appendix A7	Substitute value behavior and power-on behavior	Revision
Entire document			Deleted: description for BK housing (with integrated bus base) Renamed: F-BK housing changed to BK housing	

**Revision history**

Table D-1 Revision history

<b>Revision</b>	<b>Date</b>	<b>Contents</b>		
08	2019-10	Entire document		Addition: Axioline F backplane
		Section 6	Transport, storage, and un-packing	New
		Section 11	Axioline F backplane	New
		Section 13	Software support	Updated
		Section 14	Device replacement, device defect, and repair	New
		Section 15	Maintenance, decommissioning, and disposal	New
		Appendix A + B	Technical appendix	New structure, PDI objects supplemented

**UM EN AXL F SYS INST**

---

---

## Please observe the following notes

### **General Terms and Conditions of use for technical documentation**

Phoenix Contact reserves the right to alter, correct, and/or improve the technical documentation and the products described in the technical documentation at its own discretion and without giving prior notice, insofar as this is reasonable for the user. The same applies to any technical changes that serve the purpose of technical progress.

The receipt of technical documentation (in particular user documentation) does not constitute any further duty on the part of Phoenix Contact to furnish information on modifications to products and/or technical documentation. You are responsible to verify the suitability and intended use of the products in your specific application, in particular with regard to observing the applicable standards and regulations. All information made available in the technical data is supplied without any accompanying guarantee, whether expressly mentioned, implied or tacitly assumed.

In general, the provisions of the current general Terms and Conditions of Phoenix Contact apply exclusively, in particular as concerns any warranty liability.

This manual, including all illustrations contained herein, is copyright protected. Any changes to the contents or the publication of extracts of this document are prohibited.

Phoenix Contact reserves the right to register its own intellectual property rights for the product identifications of Phoenix Contact products that are used here. Registration of such intellectual property rights by third parties is prohibited.

Other product identifications may be afforded legal protection, even where they may not be indicated as such.

---

## How to contact us

### Internet

Up-to-date information on Phoenix Contact products and our Terms and Conditions can be found on the Internet at:

[phoenixcontact.com](http://phoenixcontact.com)

Make sure you always use the latest documentation.

It can be downloaded at:

[phoenixcontact.net/products](http://phoenixcontact.net/products)

### Subsidiaries

If there are any problems that cannot be solved using the documentation, please contact your Phoenix Contact subsidiary.

Subsidiary contact information is available at [phoenixcontact.com](http://phoenixcontact.com).

### Published by

PHOENIX CONTACT GmbH & Co. KG

Flachsmarktstraße 8

32825 Blomberg

GERMANY

Should you have any suggestions or recommendations for improvement of the contents and layout of our manuals, please send your comments to:

[tecdoc@phoenixcontact.com](mailto:tecdoc@phoenixcontact.com)



# SCATTERGOOD & JOHNSON LTD

ELECTRICAL ENGINEERING & FLUID CONTROL DISTRIBUTORS

Est.1899

At Scattergood & Johnson Ltd, we pride ourselves on being a technical distributor to specialist industries.

Working with a range of quality product suppliers across a number of specialist markets, we are not your average 'box shifter' - we are your technical and supply chain partner.

We fully support every product we sell - for free! Our internal team and external sales engineers can answer any product or application question, no matter the complexity.

Backing up this technical ability is a range of 50,000+ products available from stock for nationwide next day delivery (same day if required!), or you can collect what you need from any of our trade counters around the UK.

Select your specialist interest below to learn more about how we can help.

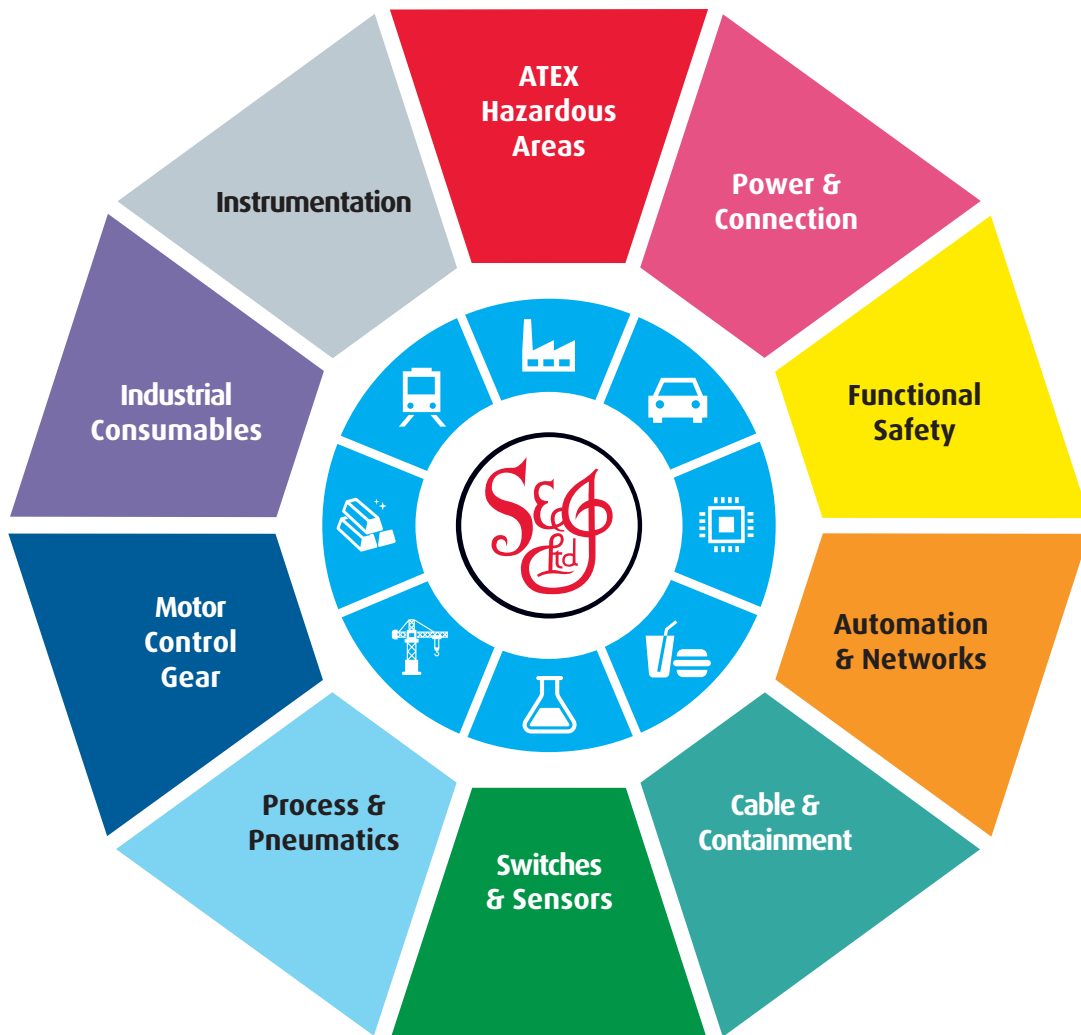

Online, In Branch and On the Road - Scattergood & Johnson Ltd, there when you need us.

# [www.scatts.co.uk](http://www.scatts.co.uk)