

# AXL F AI4 I 1H

## Axioline F, analog input module, 4 current inputs, integrated sensor supply

Data sheet  
8658\_en\_04

© PHOENIX CONTACT 2019-03-04



### 1 Description

The module is designed for use within an Axioline F station. It is used to acquire analog current signals.

**Valid from firmware version 1.10.**

#### Features

- 4 analog, bipolar input channels for the connection of current signals
- Connection of sensors in 2, 3, and 4-wire technology
- Current ranges: 0 mA ... 20 mA, 4 mA ... 20 mA,  $\pm 20$  mA
- Simultaneous scanning of all channels by means of simultaneous sampling
- High crosstalk attenuation between the channels, thanks to separate signal paths
- Particularly robust against electromagnetic interference
- Device rating plate stored



This data sheet is only valid in association with the UM EN AXL F SYS INST user manual.



Make sure you always use the latest documentation.  
It can be downloaded at: [phoenixcontact.net/product/2688491](https://phoenixcontact.net/product/2688491)

<b>2</b>	<b>Table of contents</b>	
1	Description .....	1
2	Table of contents .....	2
3	Ordering data .....	3
4	Technical data .....	4
5	Tolerance data.....	8
6	Internal circuit diagram .....	9
7	Terminal point assignment.....	10
8	Connection examples .....	10
9	Connection notes .....	11
10	Local diagnostic and status indicators .....	12
11	Process data.....	13
12	Significant values in various formats.....	14
	12.1 Significant values in IB IL format .....	14
	12.2 Significant values in S7-compatible format .....	14
	12.3 Calculation of the measured value from the process data input value.....	15
13	Parameter, diagnostics and information (PDI) .....	15
14	Standard objects .....	16
	14.1 Objects for identification (device rating plate).....	16
	14.2 Miscellaneous standard objects .....	17
	14.3 Diagnostics objects .....	18
	14.4 Objects for process data management.....	19
	14.5 Objects for device management .....	19
15	Application objects .....	20
	15.1 Parameter table (0080hex: ParaTable).....	20
	15.2 Measured value in extended float format (0082hex: Measured Value Float) .....	22
	15.3 Minimum process data value (0083hex: PD Min).....	23
	15.4 Maximum process data value (0084hex: PD Max) .....	23
16	Device descriptions .....	23

### 3 Ordering data

Description	Type	Order No.	Pcs./Pkt.
Axioline F, Analog input module, Analog inputs: 4, 0 mA ... 20 mA, 4 mA ... 20 mA, -20 mA ... 20 mA, connection method: 2, 3, 4-wire, transmission speed in the local bus: 100 Mbps, integrated sensor supply, degree of protection: IP20, including bus base module and Axioline F connectors	AXL F AI4 I 1H	2688491	1
<b>Accessories</b>			
Axioline F bus base module for housing type H (Replacement item)	AXL F BS H	2700992	5
Axioline shield connection set (contains 2 shield bus holders and 2 SK 5 shield connection clamps)	AXL SHIELD SET	2700518	1
Zack marker strip for Axioline F (device labeling), in 2 x 20.3 mm pitch, unprinted, 25-section, for individual labeling with B-STIFT 0.8, X-PEN, or CMS-P1-PLOTTER (Marking)	ZB 20,3 AXL UNPRINTED	0829579	25
Zack marker strip, flat, in 10 mm pitch, unprinted, 10-section, for individual labeling with M-PEN 0,8, X-PEN, or CMS-P1-PLOTTER (Marking)	ZBF 10/5,8 AXL UNPRINTED	0829580	50
Insert label, Roll, white, unlabeled, can be labeled with: THERMOMARK ROLLMASTER 300/600, THERMOMARK X1.2, THERMOMARK ROLL X1, THERMOMARK ROLL 2.0, THERMOMARK ROLL, mounting type: snapped into marker carrier, lettering field size: 35 x 28 mm (Marking)	EMT (35X28)R	0801602	1
<b>Documentation</b>			
User manual, English, Axioline F: System and installation	UM EN AXL F SYS INST	-	-
User manual, English, Axioline F: Diagnostic registers, and error messages	UM EN AXL F SYS DIAG	-	-

## 4 Technical data

### Dimensions (nominal sizes in mm)

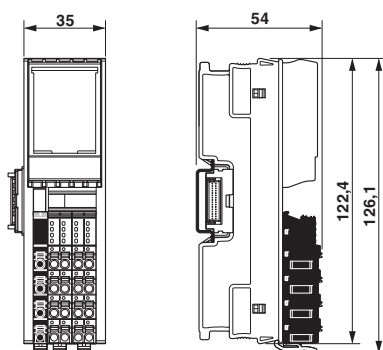

Width	35 mm
Height	126.1 mm
Depth	54 mm
Note on dimensions	The depth is valid when a TH 35-7,5 DIN rail is used (according to EN 60715).

### General data



Color	traffic grey A RAL 7042
Weight	145 g (with connectors and bus base module)
Ambient temperature (operation)	-25 °C ... 60 °C
Ambient temperature (storage/transport)	-40 °C ... 85 °C
Permissible humidity (operation)	5 % ... 95 % (non-condensing)
Permissible humidity (storage/transport)	5 % ... 95 % (non-condensing)
Air pressure (operation)	70 kPa ... 106 kPa (up to 3000 m above sea level)
Air pressure (storage/transport)	70 kPa ... 106 kPa (up to 3000 m above sea level)
Degree of protection	IP20
Protection class	III, IEC 61140, EN 61140, VDE 0140-1
Mounting position	any (no temperature derating)

### Connection data: Axioline F connector

Connection method	Push-in connection
Conductor cross section solid / stranded	0.2 mm <sup>2</sup> ... 1.5 mm <sup>2</sup> / 0.2 mm <sup>2</sup> ... 1.5 mm <sup>2</sup>
Conductor cross section [AWG]	24 ... 16
Stripping length	8 mm



Please observe the information provided on conductor cross sections in the "Axioline F: system and installation" user manual.

<b>Interface: Axioline F local bus</b>	
Number	2
Connection method	Bus base module
Transmission speed	100 Mbps
<b>Axioline F local bus supply (<math>U_{Bus}</math>)</b>	
Supply voltage	5 V DC (via bus base module)
Current draw	typ. 120 mA max. 150 mA
<b>Supply for analog modules (<math>U_A</math>)</b>	
Supply voltage	24 V DC (I/O supply and sensor supply)
Supply voltage range	19.2 V DC ... 30 V DC (including all tolerances, including ripple)
Current draw	typ. 38 mA ( $I_{IS} = 0$ mA) max. 45 mA ( $I_{IS} = 0$ mA) typ. 118 mA ( $I_{IS} = 4 \times 20$ mA (nominal load)) max. 125 mA ( $I_{IS} = 4 \times 20$ mA (nominal load)) typ. 238 mA ( $I_{IS} = 4 \times 50$ mA (full load)) max. 245 mA ( $I_{IS} = 4 \times 50$ mA (full load))
Surge protection of the supply voltage	electronic (35 V, 0.5 s)
Polarity reversal protection of the supply voltage	up to HW 02: polarity protection diode as of HW 03: parallel diode; with external 5 A fuse (for startup only)
Transient protection supply voltage	Suppressor diode
 <b>NOTE: Damage to the electronics</b>	Provide external protection for the module to protect it against polarity reversal. If you are using an external fuse, the power supply unit must be able to supply four times the nominal current of the fuse. This ensures that it trips in the event of an error.
	When using the module for the first time, protect it with a 5 A fuse. When all modules in the system are correctly connected, the 5 A fuse can be replaced with an 8 A fuse. After that, you can load the module up to 8 A.
<b>Power consumption</b>	
Power consumption	typ. 1.5 W (at $U_{Bus}$ and $U_A$ ) max. 1.83 W (at $U_{Bus}$ and $U_A$ )
<b>Supply: Sensor supply <math>U_{IS}</math></b>	
Supply voltage	24 V DC (from $U_A$ )
Current consumption	max. 50 mA (per channel)
<b>Analog inputs</b>	
Number of inputs	4
Description of the input	Differential inputs, current
Connection method	Push-in connection
Connection technology	2, 3, 4-wire, shielded
Current input signal	0 mA ... 20 mA, 4 mA ... 20 mA, -20 mA ... 20 mA
Resolution A/D	16 bit

<b>Analog inputs</b>	
A/D conversion time	31.25 $\mu$ s
Measured value representation	16 bits (15 bits + sign bit)
Data formats	IB IL, S7-compatible
Process data update	160 $\mu$ s
Input filter	30 Hz, 12 kHz and mean-value generation (can be parameterized)
Precision	0.1 % (of measuring range final value for active mean-value generation and 30 Hz filter)
Input resistance current input	104 $\Omega$ (typical)
Limit frequency (3 dB)	30 Hz 12 kHz
Open circuit response	Going to 0 mA; open-circuit detection from 4 mA ... 20 mA
Transient protection of inputs	Suppressor diode
Overload protection of the current inputs	No; $\pm 5.2$ V DC, maximum, $I_{\max} = 50$ mA
<b>Input and output address area</b>	
Input address area	8 Byte
Output address area	8 Byte
<b>Configuration and parameter data in a PROFIBUS system</b>	
Required parameter data	7 Byte
Required configuration data	6 Byte
<b>Electrical isolation/isolation of the voltage areas</b>	
Test section	Test voltage
5 V communications power (logic), 24 V supply (I/O)	500 V AC, 50 Hz, 1 min.
5 V supply (logic)/analog inputs	500 V AC, 50 Hz, 1 min.
5 V supply (logic)/functional earth ground	500 V AC, 50 Hz, 1 min.
24 V supply (I/O)/analog inputs	500 V AC, 50 Hz, 1 min.
24 V supply (I/O) / functional earth ground	500 V AC, 50 Hz, 1 min.
Analog inputs/functional earth ground	500 V AC, 50 Hz, 1 min.
<b>Mechanical tests</b>	
Vibration resistance in acc. with EN 60068-2-6/ IEC 60068-2-6	5g
Shock in acc. with EN 60068-2-27/IEC 60068-2-27	30g
Continuous shock according to EN 60068-2-27/ IEC 60068-2-27	10g

**Conformance with EMC Directive 2014/30/EU****Noise immunity test in accordance with EN 61000-6-2**Electrostatic discharge (ESD) EN 61000-4-2/  
IEC 61000-4-2

Criterion B, 6 kV contact discharge, 8 kV air discharge

Electromagnetic fields EN 61000-4-3/IEC 61000-4-3

Criterion A, Field intensity: 10 V/m

Fast transients (burst) EN 61000-4-4/IEC 61000-4-4

Criterion B, 2 kV

Transient overvoltage (surge) EN 61000-4-5/  
IEC 61000-4-5up to HW 02: Criterion B,  
DC supply lines:  $\pm 0.5$  kV/ $\pm 0.5$  kV (symmetrical/asymmetrical),  
 $\pm 1$  kV to shielded I/O cables  
as of HW 03: Criterion B,  
DC supply lines:  $\pm 3.0$  kV/ $\pm 0.5$  kV (symmetrical/asymmetrical),  
 $\pm 1$  kV to shielded I/O cables

Conducted interference EN 61000-4-6/IEC 61000-4-6

Criterion A; Test voltage 10 V

**Noise emission test according to EN 61000-6-3**

Class B

**Approvals**For the latest approvals, please visit [phoenixcontact.net/products](http://phoenixcontact.net/products).

## 5 Tolerance data

### The following applies for tolerance values:

The data is valid for nominal operation ( $U_A = 24\text{ V}$  in the default configuration (unless documented otherwise).

Default configuration: Filter with 30 Hz, 16-sample mean-value, IB IL format.

160  $\mu\text{s}$  update time (12 kHz filter, 32-sample mean value)

Tolerances at $T_A = +25^\circ\text{C}$				
Measuring range	Absolute		Relative	
	Typ.	Max.	Typ.	Max.
0 mA ... 20 mA,	$\pm 100\ \mu\text{A}$	$\pm 160\ \mu\text{A}$	$\pm 0.5\%$	$\pm 0.8\%$
4 mA ... 20 mA, $\pm 20\ \text{mA}$				

160  $\mu\text{s}$  update time, default (30 Hz filter, 16-sample average value)

Tolerances at $T_A = +25^\circ\text{C}$				
Measuring range	Absolute		Relative	
	Typ.	Max.	Typ.	Max.
0 mA ... 20 mA,	$\pm 20\ \mu\text{A}$	$\pm 60\ \mu\text{A}$	$\pm 0.10\%$	$\pm 0.30\%$
4 mA ... 20 mA, $\pm 20\ \text{mA}$				

Typical data contains offset error, gain error, and linearity error in the respective default setting.

All tolerances indicated as a percentage are related to the positive measuring range final value.

Please also observe the values for temperature drift and the tolerances under influences of electromagnetic interferences.

Tolerance and temperature response at $T_A = -25^\circ\text{C} \dots +60^\circ\text{C}$		
Measuring range	Drift	
	Typical	Maximum
0 mA ... 20 mA,	$\pm 100\ \text{ppm/K}$	$\pm 150\ \text{ppm/K}$
4 mA ... 20 mA, $\pm 20\ \text{mA}$		

The drift values refer to the relevant measuring range final value.

### Tolerances influenced by electromagnetic interference

Electromagnetic fields	EN 61000-4-3/ IEC 61000-4-3	$< \pm 0.1\%$
Fast transients (burst)	EN 61000-4-4/ IEC 61000-4-4	$< \pm 0.1\%$
Conducted interference	EN 61000-4-6/ IEC 61000-4-6	$< \pm 0.1\%$

Additional tolerances may occur due to the influence of high-frequency electromagnetic interference caused by wireless transmission systems in the near vicinity. The values specified refer to nominal operation in the event of direct interference to components without additional shielding such as a steel cabinet, etc.

The above mentioned tolerances can be reduced by providing further shielding measures for the I/O module (e.g., use of a shielded control box/control cabinet, etc.).

## 6 Internal circuit diagram

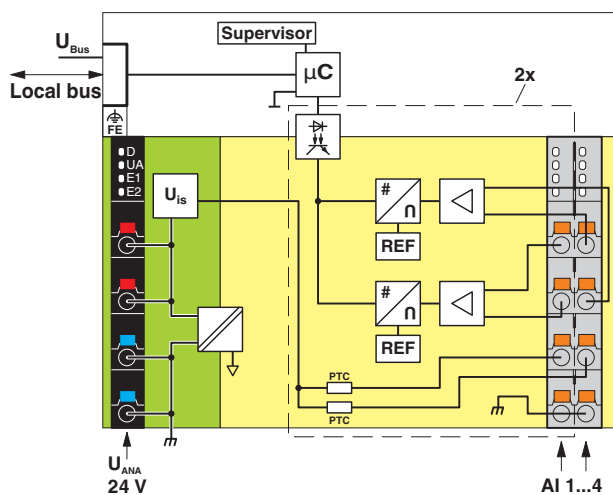

Figure 1 Internal wiring of the terminal points

Key:

- Local bus      Axioline F local bus (hereinafter referred to as local bus)
- Supervisor      Hardware monitoring
- µC      Microcontroller
- Optocoupler with bipolar buffer
- Power supply unit with electrical isolation
- Analog/digital converter
- Input amplifier
- REF      Reference voltage source
- Noiseless ground
- Analog I/O reference ground
- Logic reference ground
- Reference ground of sensor supply U<sub>is</sub>
- Electrically isolated areas

## 7 Terminal point assignment

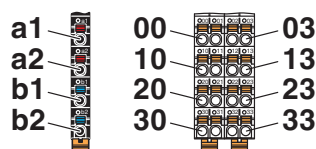

Figure 2 Terminal point assignment

Terminal point	Color	Assignment	
<b>Supply voltage input</b>			
a1, a2	Red	24 V DC (U <sub>A</sub> )	Analog module feed-in (bridged internally)
b1, b2	Blue	GND	Reference potential of the supply voltage (bridged internally)
<b>Analog inputs</b>			
00 ... 03	Orange	I1+ ... I4+	Positive current connection for channel 1 ... 4
10 ... 13	Orange	I1- ... I4-	Negative current connection for channel 1 ... 4
20 ... 23	Orange	U <sub>IS</sub> 1 ... U <sub>IS</sub> 4	24 V sensor supply for channel 1 ... 4
30 ... 33	Orange	GND	Reference potential of sensor supply

## 8 Connection examples

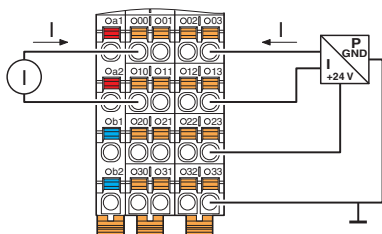

Figure 3 Connection for current measurement

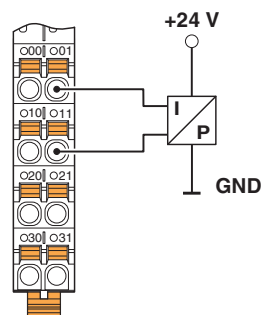

Figure 4 Passive pressure sensor at a differential current input

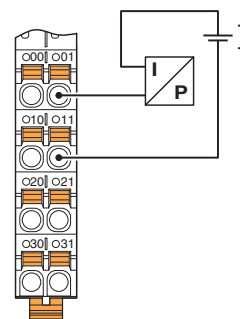

Figure 5 Differential current input with passive 2-wire transmitter (current loop)

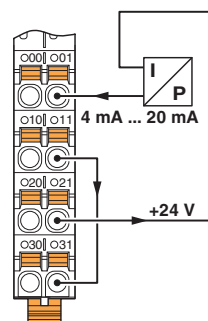

Figure 6 Differential current input with passive 2-wire transmitter (current loop)

## 9 Connection notes



**NOTE: Damage to the electronics/  
measuring errors**

Unshielded cables may lead to values outside the specified tolerance limits in environments subject to heavy noise.

- Always connect the analog actuators using shielded twisted-pair cables.

Connect the cable shield to functional earth immediately after the cables enter the control cabinet.

If a closed control cabinet is not available, connect the shield to a shield bus.

Use the AXL SHIELD SET Axioline shield connection set for an optimized connection directly in front of the module.



For further information on shielding, please refer to the UM EN AXL F SYS INST user manual.

## 10 Local diagnostic and status indicators

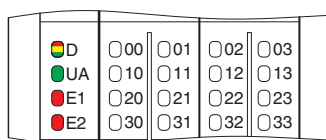

Channel errors are errors that can be associated with a channel.  
Periphery errors are errors that affect the entire module.

Figure 7 Local diagnostic and status indicators

Designation	Color	Meaning	State	Description
D	Red/ yellow/ green	Diagnostics of local bus communication		
		Run	Green on	The device is ready for operation, communication within the station is OK. All data is valid. An error has not occurred.
		Active	Green flashing	The device is ready for operation, communication within the station is OK. The data is <b>not</b> valid. No valid data provided by the controller/ higher-level network. There is no error on the module.
		Device application not active	Flashing green/yellow	The device is ready for operation, communication within the station is OK. Output data <b>cannot</b> be outputted and/or input data <b>cannot</b> be read. There is a fault on the periphery side of the module..
		Ready	Yellow on	The device is ready for operation but did not detect a valid cycle after power-up.
		Connected	Yellow flashing	The device is not (yet) part of the active configuration.
		Reset	Red on	The device is ready for operation but has lost the connection to the bus head.
		Not connected	Flashing red	The device is ready for operation but there is no connection to the previously existing device.
		Power down	Off	Device is in (power) reset.
UA	Green	U <sub>Analog</sub>	On	Supply for analog modules (U <sub>A</sub> ) present.
			Off	Supply for analog modules (U <sub>A</sub> ) not present.
E1	Red	Supply voltage error	On	Supply for analog modules (U <sub>A</sub> ) is faulty.
			Off	Supply for analog modules (U <sub>A</sub> ) is OK.
E2	Red	Error	On	I/O or channel error has occurred.
			Off	No error

Error code and status of the E1 and E2 LEDs

Error	E1 LED	E2 LED
No error	off	off
Underrange	off	on
Overrange	off	on
Open circuit	off	on
Supply voltage faulty (supply for analog modules (U <sub>A</sub> ))	on	on
Parameter table invalid	off	on
Device error	off	on
Flash format error	off	on



The error that can actually be reported depends on the measuring range. For additional information please refer to the tables with significant measured values in various formats.

## 11 Process data

The module uses four words of IN process data.

Each channel is mapped to a word.

### Input words IN0 to IN3

The measured values are transmitted to the controller board or the computer using process data input words.

The measured values are depicted in IB IL or S7-compatible format. In both cases, the measured value is displayed in 16 bit format. The data type is Integer 16 from a technical programming point of view.

INx															
15	14	13	12	11	10	9	8	7	6	5	4	3	2	1	0
Analog value															

In the IB IL format a diagnostic code is mapped to the input data in the event of an error.

Code (hex)	Cause
8001	Measuring range exceeded (overrange)
8002	Open circuit
8004	Measured value invalid or no valid measured value available
8020	Supply voltage faulty (supply for analog modules (U <sub>A</sub> ))
8040	Device faulty
8080	Below measuring range (underrange)

## 12 Significant values in various formats

### 12.1 Significant values in IB IL format

Input data		0 mA ... 20 mA	± 20 mA	4 mA ... 20 mA
hex	dec	mA	mA	mA
8001	Overrange	> +21.6747	> +21.6747	> +21.3397
7F00	32512	+21.6747	+21.6747	+21.3397
7530	30000	+20.0	+20.0	+20.0
0001	1	+0.6667 µA	+0.6667 µA	+4.0005333
0000	0	≤ 0	0	+4.0 ... +3.2
FFFF	-1		-0.6667 µA	
8AD0	-30000		-20.0	
8100	-32512		-21.6747	
8080	Underrange		< -21.6747	
8002	Open circuit			< +3.2

The maximum measured value is 7F00<sub>hex</sub>.

Depending on the measuring range, the minimum measured value is either 0000<sub>hex</sub> or 8100<sub>hex</sub>.

### 12.2 Significant values in S7-compatible format

Input data		0 mA ... 20 mA	± 20 mA	4 mA ... 20 mA
hex	dec	mA	mA	mA
7FFF	Overrange	> +23.5157	> +23.5157	> +22.8142
7EFF	32511	+23.5157	+23.5157	+22.8142
6C00	27648	+20.0	+20.0	+20.0
0001	1	+0.7234 µA	+0.7234 µA	+4.0005787
0000	0	≤ 0	0	+4.0
FFFF	-1		-0.7234 µA	+3.9994
F940	-1728		-1.25	+3.0
9400	-27648		-20.0	
8100	-32512		-23.5157	
8000	Underrange/open circuit		< -23.5157	< +1.1852

The maximum measured value is 7EFF<sub>hex</sub>.

Depending on the measuring range, the minimum measured value is either 0000<sub>hex</sub> or 8100<sub>hex</sub>.

### 12.3 Calculation of the measured value from the process data input value

The following examples explain the calculation of the measured value from the process data input value for the measuring range 4 mA to 20 mA.

PD IW = Process data input word = input data

#### IB IL format

Resolution =  $(20 \text{ mA} - 4 \text{ mA}) / 30000 = 0.0005333$

Measured value = PD-EW x 0.0005333 mA + 4 mA

#### Example 1

PD IW                       $493F_{\text{hex}} = 18751_{\text{dec}}$   
 Value x resolution       $18751 \times 0.0005333 \text{ mA} = 10 \text{ mA}$   
 + 4 mA                       $10 \text{ mA} + 4 \text{ mA} = 14 \text{ mA}$   
 Measured value          14 mA

#### S7-compatible format

Resolution =  $(20 \text{ mA} - 4 \text{ mA}) / 27648 = 0.0005787$

Measured value = PD IW x 0.0005787 mA + 4 mA

#### Example 1

PD IW                       $6C00_{\text{hex}} = 27648_{\text{dec}}$   
 Value x resolution       $27648 \times 0.0005787 \text{ mA} = 16 \text{ mA}$   
 + 4 mA                       $16 \text{ mA} + 4 \text{ mA} = 20 \text{ mA}$   
 Measured value          20 mA

#### Example 2

PD IW                       $F940_{\text{hex}} \rightarrow FFFF_{\text{hex}} - F940_{\text{hex}} + 1$   
                                   $= -1728_{\text{dec}}$   
 Value x resolution       $-1728 \times 0.0005787 \text{ mA} = -1 \text{ mA}$   
 + 4 mA                       $-1 \text{ mA} + 4 \text{ mA} = 3 \text{ mA}$   
 Measured value          3 mA

## 13 Parameter, diagnostics and information (PDI)

Parameter and diagnostic data as well as other information is transmitted as objects via the PDI channel of the Axioline F station.

The standard and application objects stored in the module are described in the following section.

Please refer to the UM EN AXL F SYS INST for an explanation of the data types.

The following applies to all tables below:

Abbreviation	Meaning
A	Number of elements
L	Length of the elements in bytes
R	Read
W	Write



Each visible string is terminated with a null terminator (00<sub>hex</sub>). The length of a visible-string-type element is therefore at least one byte larger than the number of user data items.

If the number of user data items plus null terminator is smaller than the specified length of the element, the visible string will be populated with a null character (00<sub>hex</sub>).



For detailed information on PDI objects, please refer to the UM EN AXL F SYS INST user manual.

## 14 Standard objects

### 14.1 Objects for identification (device rating plate)

Index (hex)	Object name	Data type	A	L	Rights	Meaning	Contents
<b>Manufacturer</b>							
0001	VendorName	Visible String	1	16	R	Vendor name	Phoenix Contact
0002	VendorID	Visible String	1	7	R	Vendor ID	00A045
0003	VendorText	Visible String	1	49	R	Vendor text	Components and systems for industrial automation
0012	VendorURL	Visible String	1	30	R	Vendor URL	http://www.phoenixcontact.com
<b>Module - general</b>							
0004	DeviceFamily	Visible String	1	14	R	Device family	I/O analog IN
0006	ProductFamily	Visible String	1	6	R	Product family	AXL F
000E	CommProfile	Visible String	1	4	R	Communication profile	633
000F	DeviceProfile	Visible String	1	5	R	Device profile	0010
0011	ProfileVersion	Record of Visible Strings	2	11; 20	R	Profile version	2011-12-07; Basis - Profil V2.0
0017	Language	Record of Visible Strings	2	6; 8	R	Language	en-us; English
<b>Module - special</b>							
0005	Capabilities	Visible String	1	8	R	Capabilities	Energ_0
0007	ProductName	Visible String	1	15	R	Product name	AXL F A14 I 1H
0008	SerialNo	Visible String	1	11	R	Serial number	e. g., 1234512345
0009	ProductText	Visible String	1	24	R	Product text	4 analog input channels
000A	OrderNumber	Visible String	1	8	R	Order No.	2688491
000B	HardwareVersion	Record of Visible Strings	2	11; 3	R	Hardware version	e. g., 2010-06-21; 01
000C	FirmwareVersion	Record of Visible Strings	2	11; 6	R	Firmware version	e. g., 2010-06-21; V1.10
000D	PChVersion	Record of Visible Strings	2	11; 6	R	PDI version	2010-01-08; V1.00
0037	DeviceType	Octet string	1	8	R	Device type	00 20 00 08 00 00 00 A6 <sub>hex</sub>
003A	VersionCount	Array of UINT16	4	4 * 2	R	Version counter	e. g., 0007 0001 0001 0001 <sub>hex</sub>
<b>Use of the device</b>							
0014	Location	Visible String	1	59	R/W	Location	Can be completed by the user.
0015	EquipmentIdent	Visible String	1	59	R/W	Equipment identifier	Can be completed by the user.
0016	ApplDeviceAddr	UINT16	1	2	R/W	Application device address	Can be completed by the user.

## 14.2 Miscellaneous standard objects

Index (hex)	Object name	Data type	A	L	Rights	Meaning/contents	
<b>Object descriptions</b>							
0038	ObjDescrReq	Record	2	3	R/W	Object description request	
0039	ObjDescr	Record			R	Object description	
<b>Diagnostics objects</b>							
0018	DiagState	Record	6	2; 1; 1; 2; 1; 14	R	Diagnostic state	*
0019	ResetDiag	UINT8	1	1	R/W	Reset diagnostic messages	*
<b>Objects for process data management</b>							
0025	PDIN	Octet string	1	8	R	Input process data	*
0026	PDOOUT	Octet string	1	8	R	OUT process data, not applicable	
003B	PDIN_Descr	Array of Records	3	8; 2; 2	R	Description of the IN process data	
003C	PDOOUT_Descr	Array of Records	3	8; 2; 2	R	Description of the output process data	
<b>Objects for device management</b>							
002D	ResetParam	UINT8	1	1	R/W	Reset parameterization	*
002E	Checksum	Unsigned 32	1	4	R	Checksum	*

The objects marked in the last column with an \* are described in more detail in the next sections.

The description of the other objects is to be found in the user manual UM EN AXL F SYS INST.

The objects 0038<sub>hex</sub>, 0039<sub>hex</sub>, 003B<sub>hex</sub> and 003C<sub>hex</sub> are only applicable to tools.

### 14.3 Diagnostics objects

#### 14.3.1 Diagnostics state (0018<sub>hex</sub>: DiagState)

This object is used for a structured message of an error.

0018 <sub>hex</sub> : Diagnostics state (read)					
Subindex	Data type	Length in bytes	Meaning	Contents	
0	Record	21	Diagnostic state	Complete diagnostics information	
1	UINT16	2	Error number	0 ... 65535 <sub>dec</sub>	
2	UINT8	1	Priority	00 <sub>hex</sub>	No error
				01 <sub>hex</sub>	Error
				02 <sub>hex</sub>	Warning
				81 <sub>hex</sub>	Error removed
				82 <sub>hex</sub>	Warning eliminated
3	UINT8	1	Channel/group/module	00 <sub>hex</sub>	No error
				01 <sub>hex</sub>	Channel 1
				:	:
				04 <sub>hex</sub>	Channel 4
				FF <sub>hex</sub>	entire device
4	UINT16	2	Error code	See table below	
5	UINT8	1	More follows	00 <sub>hex</sub>	
6	Visible String	14	Text	See table below	



The message with priority 81<sub>hex</sub> or 82<sub>hex</sub> is a one-off, internal message to the bus coupler. The bus coupler transfers this error message to the error mechanisms of the higher-level system.

Error and status of the local diagnostics and status indicators

Subindex	2	3	4	6	Process data	LED			
	Priority	Channel/ group/ module	Error code	Text		D	UA	E1	E2
Error	hex	hex	hex						
No error	00	00	0000	Status OK	xxxx	●	●	○	○
Supply voltage faulty (supply for analog modules (U <sub>A</sub> ))	01	FF	5160	Supply fail	8020	✱	○	●	●
Device error	01	FF	6301	CS FLASH	8040	●	●	○	●
Flash format error	01	FF	6302	FO FLASH	8040	●	●	○	●
Parameter table invalid	01	FF	6320	Invalid para	8010	●	●	○	●
Open circuit	01	01 ... 04	7710	Open circuit	8002	●	●	○	●
Overrange	02	01 ... 04	8910	Overrange	8001	●	●	○	●
Underrange	02	01 ... 04	8920	Underrange	8080	●	●	○	●

○ Off  
● On

● Green on  
✱ Flashing green/yellow

### 14.3.2 Reset diagnostic messages (0019<sub>hex</sub>: ResetDiag)

You can delete the diagnostics memory and acknowledge the diagnostic messages with this object.

0019 <sub>hex</sub> : Reset diagnostic messages (read, write)				
Subindex	Data type	Length in bytes	Code (hex)	Meaning
0	UINT8	1	00	Permit all diagnostic messages
			02	Delete and acknowledge all diagnostic messages that are still pending
			06	Delete and acknowledge all diagnostic messages, reset the error counter, and do not permit new diagnostic messages
			Other	Reserved

## 14.4 Objects for process data management

### IN process data (0025<sub>hex</sub>: PDIN)

You can read the IN process data of the module with this object.

The structure corresponds to the representation in the "Process data" section.

0025 <sub>hex</sub> : IN process data (read)			
Subindex	Data type	Length in bytes	Meaning
0	Octet string	8	Input process data

## 14.5 Objects for device management

These objects are available as of firmware 1.10.

### 14.5.1 Reset parameterization (002D<sub>hex</sub>: ResetParam)

This object is used to reset the module to the default settings.

To reset the module value 01<sub>hex</sub> must be transferred during write access. Any other values are not permissible and will be acknowledged with an error.

Then the default settings of the channels are loaded and all the user-set parameters are reset.

### 14.5.2 Checksum (002E<sub>hex</sub>: CheckSum)

The data of the startup objects is verified with this checksum. The checksum only changes if an object relevant for startup has been changed. The checksum is therefore suitable for comparing the parameterization.

## 15 Application objects

In the case of valid parameters, the parameterization is stored in the module permanently.

Index (hex)	Object name	Data type	A	L	Rights	Meaning/contents
0080	ParaTable	Array of UINT16	6	6 * 2	R/W	Parameter table
0082	Measured Value Float	Array of Records	4	4 * 6	R	Measured values in the extended float format
0083	PD Min	Array of UINT16	4	4 * 2	R	Minimum process data value
0084	PD Max	Array of UINT16	4	4 * 2	R	Maximum process data value

### 15.1 Parameter table (0080<sub>hex</sub>: ParaTable)

Parameterize the module using this object.

In the case of valid parameters, the parameterization is stored in the module permanently.

After resetting, the module works with the last permanently stored data. Upon delivery, the module works with the default data (default settings).

0080 <sub>hex</sub> : Parameter table (read, write)				
Subindex	Data type	Length in bytes	Meaning	Default value
0	Array of UINT16	6 * 2	Read/write all elements	See subindices
1	UINT16	2	Parameterization of channel 1	0004 <sub>hex</sub>
:	UINT16	2	:	0004 <sub>hex</sub>
4	UINT16	2	Parameterization of channel 4	0004 <sub>hex</sub>
5	UINT16	2	Data format	0000 <sub>hex</sub>
6	UINT16	2	Reserved	0000 <sub>hex</sub>

## Parameterization channel 1 ... channel 4

## Parameterization word

15	14	13	12	11	10	9	8	7	6	5	4	3	2	1	0
0	0	0	Filter	0	0	Mean-value	0	0	0	0	0	Measuring range			

Filter	Code (bin)	Code (hex)
30 Hz (default)	0	0
12 kHz	1	1

Measuring range	Code (bin)	Code (hex)
0 mA ... 20 mA (default)	0100	4
±20 mA	0101	5
4 mA ... 20 mA	0110	6
Channel inactive	1111	F
Reserved	Other	

Mean-value	Code (bin)	Code (hex)
16-sample (default)	00	0
No mean-value	01	1
4-sample	10	2
32-sample	11	3

## Data format

15	14	13	12	11	10	9	8	7	6	5	4	3	2	1	0
0	0	0	0	0	0	Data format	0	0	0	0	0	0	0	0	0

Data format	Code (bin)	Code (hex)
IB IL (default)	00	0
Reserved	01	1
S7-compatible	10	2
Reserved	11	3



Set all reserved bits to 0.

## 15.2 Measured value in extended float format (0082<sub>hex</sub>: Measured Value Float)

You can read the IN process data in IB IL or S7-compatible format with the 0025<sub>hex</sub> object.

The 0082<sub>hex</sub> object is also available.

This object provides the measured value in the highest internal accuracy of the terminal in the float format.

0082 <sub>hex</sub> : Measured value in extended float format (read)			
Subindex	Data type	Length in bytes	Meaning
0	Array of Records	4 * 6	Read all elements
1	Record	6	Measured value for channel 1
:	:	:	:
4	Record	6	Measured value channel 4

### Measured value channel 1 ... channel 4

Element	Data type	Length in bytes	Meaning
1	Float 32	4	Measured value in float format according to IEEE 754
2	UINT8	1	Status
3	UINT8	1	Unit

Structure of the float format according to IEEE 754 in the bit representation:

VEEE EEEE	EMMM MMMM	MMMM MMMM	MMMM MMMM
-----------	--------------	--------------	--------------

- V 1 sign bit, 0: positive, 1: negative
- E 8 bits exponent with offset 7F<sub>hex</sub>
- M 23 bits mantissa

Some example values for conversion from floating point to hexadecimal representation:

Floating point	Hexadecimal representation
1.0	3F 80 00 00
10.0	41 20 00 00
1.03965528	3F 85 13 6D
- 1.0	BF 80 00 00

## Extended Float Format

Extended Float Format is a specially defined format. It consists of the measured value in float format, a status, and a unit.

Status is necessary because the float format defines no patterns providing information on the status of the numerical value.

The status corresponds to the LSB of the diagnostic code in IB IL format (e.g., overrange: status = 01, diagnostic code = 8001<sub>hex</sub>). If status = 0, the measured value is valid.

Unit	Code
Milliampere (mA)	39 (27 <sub>hex</sub> )

Status	Code
Measured value is valid	00 <sub>hex</sub>
Measured value is invalid	Other

### 15.3 Minimum process data value (0083<sub>hex</sub>: PD Min)

Object 0083<sub>hex</sub> can be used to read the minimum IN process data values.

The values are initialized after each parameterization. The highest value is assigned for the minimum process data value.

PD Min = 7FFF 7FFF 7FFF 7FFF<sub>hex</sub>

On every analog conversion, the PD Min value is compared with the current measured values and overwritten if necessary.

0083 <sub>hex</sub> : Minimum process data value (read)			
Subindex	Data type	Length in bytes	Meaning
0	Array of Integer 16	4 * 2	Read all elements
1	Integer 16	2	Minimum process data value channel 1
:	:	:	:
4	Integer 16	2	Minimum process data value channel 4

### 15.4 Maximum process data value (0084<sub>hex</sub>: PD Max)

Object 0084<sub>hex</sub> can be used to read the maximum IN process data values.

The values are initialized after each parameterization. The lowest value is assigned for the maximum process data value.

PD Max = 8000 8000 8000 8000<sub>hex</sub>

On every analog conversion, the PD Max value is compared with the current measured values and overwritten if necessary.

0084 <sub>hex</sub> : Maximum process data value (read)			
Subindex	Data type	Length in bytes	Meaning
0	Array of Integer 16	4 * 2	Read all elements
1	Integer 16	2	Maximum process data value channel 1
:	:	:	:
4	Integer 16	2	Maximum process data value channel 4

## 16 Device descriptions

The device is described in the device description files. The device descriptions for controllers from Phoenix Contact are included in PC Worx and the corresponding service packs.

The device description files for other systems are available for download at [phoenixcontact.net/products](http://phoenixcontact.net/products) in the download area of the bus coupler used.



# SCATTERGOOD & JOHNSON LTD

ELECTRICAL ENGINEERING & FLUID CONTROL DISTRIBUTORS

Est.1899

At Scattergood & Johnson Ltd, we pride ourselves on being a technical distributor to specialist industries.

Working with a range of quality product suppliers across a number of specialist markets, we are not your average 'box shifter' - we are your technical and supply chain partner.

We fully support every product we sell - for free! Our internal team and external sales engineers can answer any product or application question, no matter the complexity.

Backing up this technical ability is a range of 50,000+ products available from stock for nationwide next day delivery (same day if required!), or you can collect what you need from any of our trade counters around the UK.

Select your specialist interest below to learn more about how we can help.

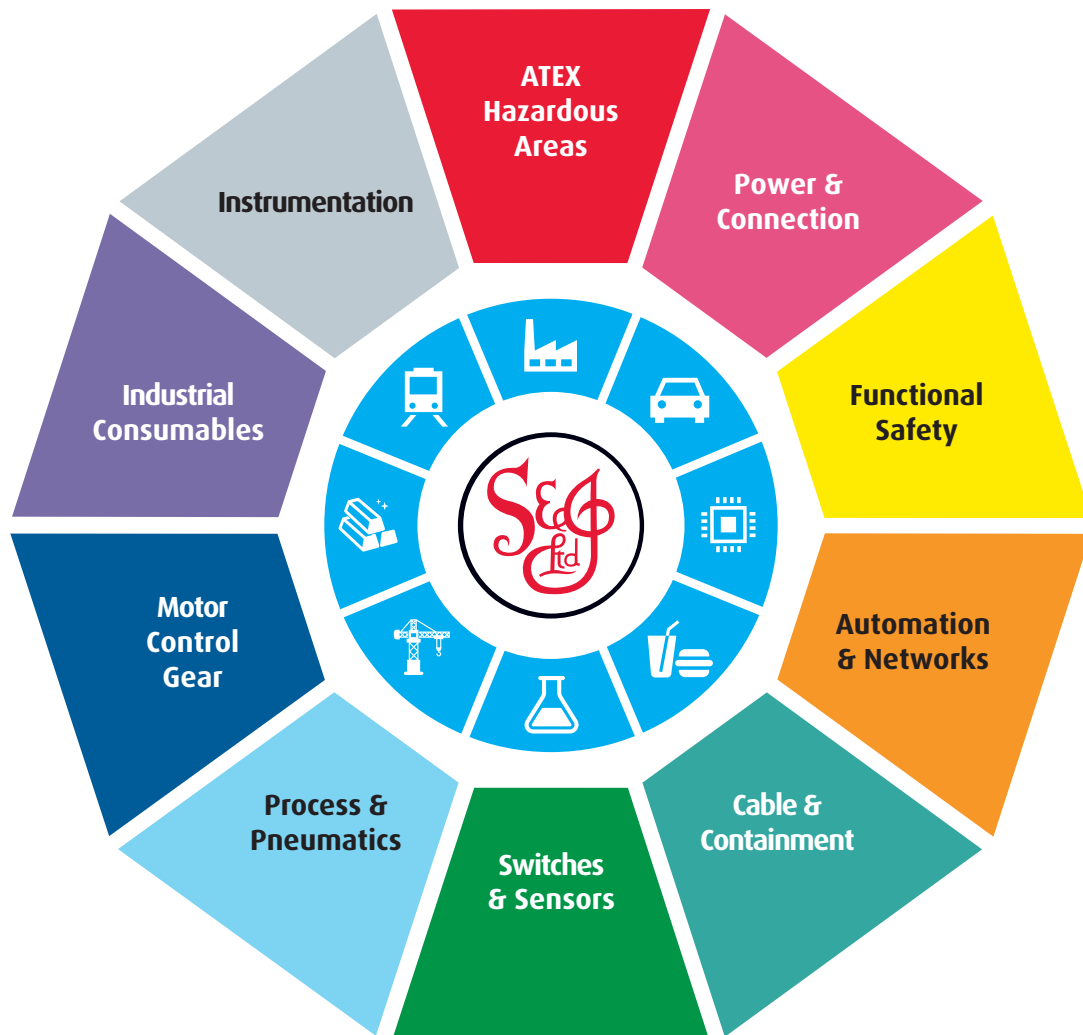

Online, In Branch and On the Road - Scattergood & Johnson Ltd, there when you need us.

# [www.scatts.co.uk](http://www.scatts.co.uk)