

# AXL F BK EC

## Axioline F bus coupler for EtherCAT®

Data sheet  
8479\_en\_09

© PHOENIX CONTACT 2018-07-12



### 1 Description

The bus coupler is intended for use within an EtherCAT® network and represents the link to the Axioline F I/O system. Up to 63 Axioline F devices can be connected to the bus coupler.

EtherCAT® is a registered trademark and patented technology, licensed by Beckhoff Automation GmbH, Germany.

A corresponding ESI file is available for integrating the Axioline F station into the programming system.

It can be downloaded at: [phoenixcontact.net/product/2688899](http://phoenixcontact.net/product/2688899)

**Valid from firmware version 1.10.**

#### EtherCAT® features

- 2 Ethernet-Ports
- Automatic addressing
- Rotary coding switch for assigning the ID for the “Explicit Device ID” mechanism
- Detail of the station as a modular EtherCAT® device using a Modular Device Profile (MDP)

- Detail of the station as a block device is possible
- Acyclic data communication (mailbox protocols)
- Cyclic data communication
- Supports the EtherCAT® cycle time of < 100 µs

#### Features of Axioline F

- Typical cycle time of the Axioline F local bus is around 10 µs
- Runtime in the bus coupler is negligible (goes to 0 µs)
- Firmware can be updated
- Diagnostic and status indicators

#### Abbreviations used

CoE	CAN application protocol over EtherCAT®
DC	Distributed clocks
FoE	File access over EtherCAT®



This data sheet is only valid in association with the UM EN AXL F SYS INST user manual.



Make sure you always use the latest documentation.  
It can be downloaded from the product at [phoenixcontact.net/products](http://phoenixcontact.net/products).

---

<b>2</b>	<b>Table of contents</b>	
1	Description .....	1
2	Table of contents .....	2
3	Ordering data .....	3
4	Technical data .....	5
5	Internal circuit diagram .....	8
6	Connecting EtherCAT® and supply .....	9
7	Connection example.....	10
8	Configuration via rotary encoding switch .....	10
9	Local diagnostic and status indicators .....	11
10	Reset button .....	13
11	Service interface.....	13
12	MAC address.....	13
13	Parameter data.....	14
14	Substitute value behavior .....	14
15	Synchronizing the application.....	14
16	Object dictionary.....	16
17	Process data.....	25
18	Diagnostics strategy .....	26
19	Firmware update.....	29

### 3 Ordering data

Description	Type	Order No.	Pcs./Pkt.
Axioline F, Bus coupler, EtherCAT®, RJ45 socket, transmission speed in the local bus: 100 Mbps, degree of protection: IP20, including bus base module and Axioline F connector	AXL F BK EC	2688899	1
<b>Accessories</b>			
Axioline F bus base module for housing type BK (Replacement item)	AXL BS BK	2701422	5
Axioline F short power connector (for e.g., AXL F BK ...) (Replacement item)	AXL CN S/UL	2701421	5
RJ45 connector, shielded, with bend protection sleeve, 2 pieces, gray for straight cables, for assembly on site. For connections that are not crossed, it is recommended that you use the connector set with gray bend protection sleeve. (Connector/Adapter)	FL PLUG RJ45 GR/2	2744856	1
RJ45 connector, shielded, with bend protection sleeve, 2 pieces, green for crossed cables, for assembly on site. For connections that are crossed, it is recommended that the connector set with green bend protection sleeves is used. (Connector/Adapter)	FL PLUG RJ45 GN/2	2744571	1
CAT5-SF/UTP cable (J-02YS(ST)C HP 2 x 2 x 24 AWG), heavy-duty installation cable, 2 x 2 x 0.22 mm <sup>2</sup> , solid conductor, shielded, outer sheath: 7.8 mm diameter, inner sheath: 5.75 mm ± 0.15 mm diameter (Cable/conductor)	FL CAT5 HEAVY	2744814	1
CAT5-SF/UTP cable (J-LI02YS(ST)C H 2 x 2 x 26 AWG), light-duty, flexible installation cable 2 x 2 x 0.14 mm <sup>2</sup> , stranded, shielded, outer sheath: 5.75 mm ± 0.15 mm diameter (Cable/conductor)	FL CAT5 FLEX	2744830	1
Crimping pliers, for assembling the RJ45 plugs FL PLUG RJ45..., for assembly on site (Tools)	FL CRIMPTOOL	2744869	1
Zack marker strip for Axioline F (device labeling), in 2 x 20.3 mm pitch, unprinted, 25-section, for individual labeling with B-STIFT 0.8, X-PEN, or CMS-P1-PLOTTER (Marking)	ZB 20,3 AXL UNPRINTED	0829579	25
Zack marker strip, flat, in 10 mm pitch, unprinted, 10-section, for individual labeling with M-PEN 0,8, X-PEN, or CMS-P1-PLOTTER (Marking)	ZBF 10/5,8 AXL UNPRINTED	0829580	50
Insert label, Roll, white, unlabeled, can be labeled with: THERMOMARK ROLL, THERMOMARK ROLL X1, THERMOMARK ROLLMaster 300/600, THERMOMARK X1.2, THERMOMARK S1.1, mounting type: snapped into marker carrier, lettering field size: 35 x 18.7 mm (Marking)	EMT (35X18,7)R	0801831	1
Connecting cable, for connecting the controller to a PC for PC Worx and LOGIC+, USB A to micro USB B, 2 m in length. (Cable/conductor)	CAB-USB A/MICRO USB B/ 2,0M	2701626	1

Documentation	Type	Order No.	Pcs./Pkt.
User manual, English, Starting up the Axioline F bus coupler for EtherCAT® using TwinCAT®	UM EN AXL F BK EC	-	-
User manual, English, Axioline F: System and installation	UM EN AXL F SYS INST	-	-
User manual, English, Axioline F: Diagnostic registers, and error messages	UM EN AXL F SYS DIAG	-	-
User manual, English, AXL F BK EC bus coupler: Access to PDI objects and startup parameterization	AH EN AXL F BK EC - TUNNEL	-	-
Application note, English, Firmware update on the AXL F BK EC or IL EC BK-PAC bus coupler with TwinCAT®	AH EN FIRMWARE UPDATE AXL F BK EC / IL EC BK-PAC	-	-
Application note, English, Updating the firmware of an Axioline F bus coupler	AH EN TFTP FIRMWARE UPDATE AXL F BK	-	-
Quick start guide, English, Handling an Axioline F station under Startup+	UM QS EN STARTUP+	-	-

## 4 Technical data

### Dimensions (nominal sizes in mm)

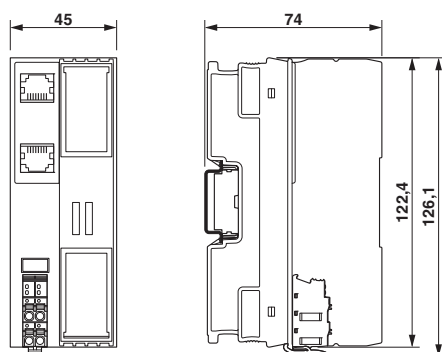

Width	45 mm
Height	126.1 mm
Depth	74 mm
Note on dimensions	The depth is valid when a TH 35-7,5 DIN rail is used (according to EN 60715).

### General data

Color	traffic grey A RAL 7042
Weight	177 g (with connector and bus base module)
Ambient temperature (operation)	-25 °C ... 60 °C (Mounting position: wall mounting on horizontal DIN rail) -25 °C ... 55 °C (Mounting position: any)
Ambient temperature (storage/transport)	-40 °C ... 85 °C
Permissible humidity (operation)	5 % ... 95 % (non-condensing)
Permissible humidity (storage/transport)	5 % ... 95 % (non-condensing)
Air pressure (operation)	70 kPa ... 106 kPa (up to 3000 m above sea level)
Air pressure (storage/transport)	70 kPa ... 106 kPa (up to 3000 m above sea level)
Degree of protection	IP20
Protection class	III, IEC 61140, EN 61140, VDE 0140-1
Mounting position	any (observe temperature derating)

### Connection data: Axioline F connector

Connection method	Push-in connection
Conductor cross section solid / stranded	0.2 mm <sup>2</sup> ... 1.5 mm <sup>2</sup> / 0.2 mm <sup>2</sup> ... 1.5 mm <sup>2</sup>
Conductor cross section [AWG]	24 ... 16
Stripping length	8 mm



Please observe the information provided on conductor cross sections in the "Axioline F: system and installation" user manual.

**Interface: EtherCAT®**

Number	2
Connection method	RJ45 socket
Note on the connection method	Auto negotiation and autocrossing
Transmission speed	100 Mbps (full duplex)
Cycle Time	100 µs
Transmission physics	Ethernet in RJ45 twisted pair
Transmission length	max. 100 m

**Interface: Axioline F local bus**

Number	1
Connection method	Bus base module
Transmission speed	100 Mbps

**Interface: Service**

Number	1
Connection method	Micro USB type B

**System limits**

Amount of process data	1024 Byte (for each data direction)
Number of supported devices	max. 63 (per station)
Number of local bus devices that can be connected	max. 63

**NOTE: Electronics may be damaged when overloaded**

Observe the logic current consumption of each device when configuring an Axioline F station. It is specified in every module-specific data sheet. The current consumption can differ depending on the individual module. The permissible number of devices that can be connected therefore depends on the specific station structure.

**EtherCAT®**

Mailbox protocols	CAN application protocol over EtherCAT®, File access over EtherCAT®
Type of addressing	Auto-increment addressing Fixed position addressing Logical addressing Explicit device ID
Specification	ETG.1000 V1.02

**Communications power  $U_L$  feed-in (the supply of the Axioline F local bus  $U_{BUS}$  is generated from  $U_L$ )**

Supply voltage	24 V DC
Supply voltage range	19.2 V DC ... 30 V DC (including all tolerances, including ripple)
Current draw	typ. 105 mA (without I/Os and $U_L = 24$ V) max. 570 mA (with 2 A at $U_{BUS}$ for the I/Os and $U_L = 24$ V)
Power consumption	typ. 2.5 W (without I/Os) max. 13.7 W (with 2 A load at $U_{BUS}$ for the I/Os)

**Communications power  $U_L$  feed-in (the supply of the Axioline F local bus  $U_{Bus}$  is generated from  $U_L$ )**

Surge protection of the supply voltage electronic

Polarity reversal protection of the supply voltage electronic

**NOTE: Electronics may be damaged when overloaded**

Provide external fuses for the 24 V  $U_L$  area. If you are using an external fuse, the power supply unit must be able to supply four times the nominal current of the fuse. This ensures that it trips in the event of an error.

**Axioline F local bus supply ( $U_{Bus}$ )**

Supply voltage 5 V DC (via bus base module)

Power supply unit 2 A

**Error messages to the higher level control or computer system**

Emergency messages

Messages via object 10F3<sub>hex</sub> Diagnosis history**Mechanical tests**Vibration resistance in acc. with EN 60068-2-6/  
IEC 60068-2-6 5g

Shock in acc. with EN 60068-2-27/IEC 60068-2-27 30g

Continuous shock according to EN 60068-2-27/  
IEC 60068-2-27 10g**Conformance with EMC Directive 2014/30/EU****Noise immunity test in accordance with EN 61000-6-2**Electrostatic discharge (ESD) EN 61000-4-2/  
IEC 61000-4-2 Criterion B, 6 kV contact discharge, 8 kV air discharge

Electromagnetic fields EN 61000-4-3/IEC 61000-4-3 Criterion A, Field intensity: 10 V/m

Fast transients (burst) EN 61000-4-4/IEC 61000-4-4 Criterion B, 2 kV

Transient overvoltage (surge) EN 61000-4-5/  
IEC 61000-4-5 Criterion B, DC supply lines:  $\pm 0.5$  kV/ $\pm 0.5$  kV (symmetrical/  
asymmetrical), fieldbus cable shield:  $\pm 1$  kV

Conducted interference EN 61000-4-6/IEC 61000-4-6 Criterion A; Test voltage 10 V

**Noise emission test according to EN 61000-6-3** Class B**Approvals**For the latest approvals, please visit [phoenixcontact.net/products](http://phoenixcontact.net/products).

## 5 Internal circuit diagram

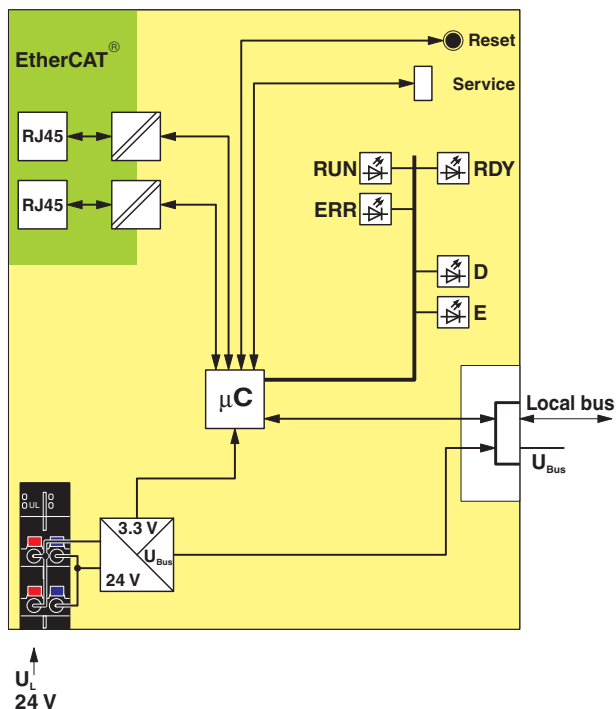

Key:

- FE Functional earth ground
- Service Service interface
- Reset Reset button
- Local bus Axioline F local bus (hereinafter referred to as local bus)
- RJ45 RJ45 interface
- Power supply unit with electrical isolation
- µC Microcontroller
- Power supply unit
- LED
- Electrically isolated areas

Figure 1 Internal wiring of the terminal points

## 6 Connecting EtherCAT® and supply

### 6.1 Connecting EtherCAT®

Connect EtherCAT® to the bus coupler via an 8-pos. RJ45 connector.

The EtherCAT® connections are directional.

Designation	Direction	Note
X1	IN	Connecting the cable from the master.
X2	OUT	Connecting the cable to additional slaves.

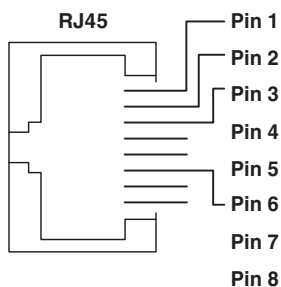

Figure 2 Pin assignment of the Ethernet socket (RJ45)

For the pin assignment, refer to the following table:

Pin	Assignment
1	TxD + (transmit data +)
2	TxD - (transmit data -)
3	RxD+ (receive data +)
4	Reserved
5	Reserved
6	RxD- (receive data -)
7	Reserved
8	Reserved



**Auto crossover**  
Both Ethernet interfaces are provided with the auto crossover function.



**Shielding**  
The shielding ground of the connected twisted pair cables is electrically connected with the socket. When connecting network segments, avoid ground loops, potential transfers, and voltage equalization currents via the braided shield.



**Observe bending radii**  
The housing dimensions specified under "Dimensions" refer to the bus coupler with I/O connectors without Ethernet connection. When installing the bus coupler in a control box, observe the bending radii of the Ethernet cables and the connectors used (e.g., FL CAT5 FLEX: 30 mm for fixed installation and FL CAT5 HEAVY: 30 mm without outer sheath and 45 mm with outer sheath). If required, use angled RJ45 connectors to maintain these bending radii.

### 6.2 Connecting the supply voltage - terminal point assignment

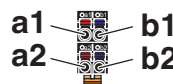

Figure 3 Terminal point assignment

Terminal point	Color	Assignment
<b>Supply voltage input</b>		
a1, a2	Red	24 V DC (U <sub>L</sub> ) Supply of the logic voltage (internally jumpered)
b1, b2	Blue	GND Reference potential of the supply voltage (bridged internally)

## 7 Connection example

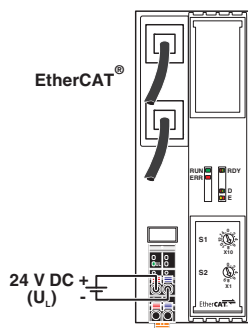

Figure 4 Connection of the cables

## 8 Configuration via rotary encoding switch

You can assign the "Device Identification Value" using the rotary coding switches.

After modifying the switch position, restart the bus coupler, as the modification to the switch position does not take effect during operation.

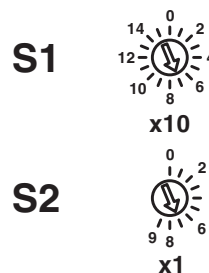

Figure 5 Rotary encoding switch

The code results from the sum of  $S1 \times 10$  plus  $S2 \times 1$ . The image shows code 77 ( $7 \times 10 + 7$ ).

S1	S2	Code	Function
0 ... 15	0 ... 9	01 ... 159	Device Identification Value

### Switch position 01 ... 159

Set the EtherCAT<sup>®</sup> explicit device identification manually with this switch position.

## 9 Local diagnostic and status indicators

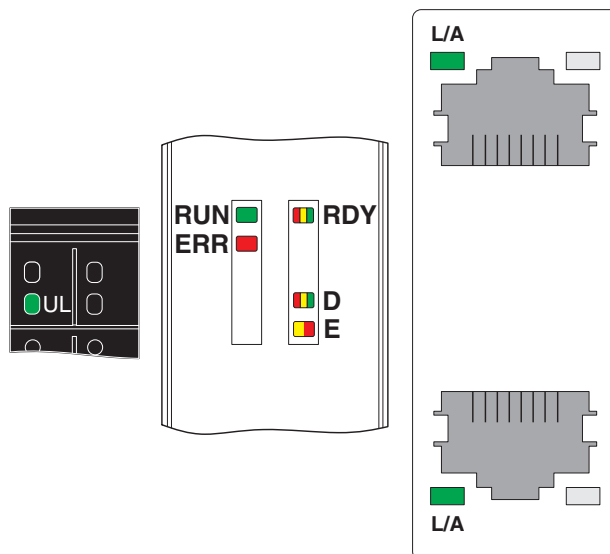

Figure 6 Local diagnostic and status indicators

Designation	Color	Meaning	State	Description
UL	Green	U <sub>Logic</sub>	ON	Communications power supply present.
			OFF	Communications power supply not present.
RUN	Green	RUN	OFF	Bus coupler in Init state
			Flashing slowly (2.5 Hz)	Bus coupler in Pre-Operational state
			Single pulse	200 ms on, 1000 ms off: bus coupler in Safe-Operational state
			ON	Bus coupler in Operational state
			Flashing (10 Hz)	Bus coupler in Bootstrap state
ERR	Red	Error	OFF	No error
			Flashing slowly (2.5 Hz)	Configuration error, a state transition initiated by the master cannot be executed
			Single pulse	200 ms on, 1000 ms off: local application error
			Double pulse	200 ms on, 200 ms off, 200 ms on, 1000 ms off: watchdog timeout
			ON	Critical internal error
RDY	Green/ yellow/ red	Ready	Green ON	Device is ready for operation.
			Flashing green/ yellow	Communications power undervoltage or surge voltage Overtemperature
			Yellow ON	Firmware/bus coupler is booting
			Yellow flashing	Firmware update is being performed.
			Flashing yellow/red	Firmware update has failed.
			Red ON	Rotary encoding switches are set to an invalid/reserved position.
			OFF	Device is not ready for operation.

Designation	Color	Meaning	State	Description
D	Green/ yellow/ red	Diagnostics	Green ON	The station is ready for operation, communication within the station is OK. All data is valid. There are no faults.
			Green flashing	The station is ready for operation, communication within the station is OK. The data is <b>not</b> valid. Valid data from the controller/higher-level network not available. There is no fault in the module.
			Yellow ON	The station is ready for operation, no data exchange taking place.
			Yellow flashing	Access from Startup+ in I/O check mode
			Flashing yellow/red	Local bus error during active I/O check
			Flashing red	Local bus error on startup
			Red ON	General local bus error
				Communication error
				Local bus device has been removed or configured device is missing.
				Reset at a local bus device
			Serious device error at a local bus device (local bus device can no longer be reached)	
E	Yellow/ red	Error	Yellow ON	I/O warning at a local bus device
			Red ON	I/O error at a local bus device
L/A	Green	Link/ Activity	Green ON	Connection present at EC IN/EC OUT.
			Green flashing	Transmission or reception of Ethernet telegrams at EC IN / EC OUT.
			OFF	Connection not present at EC IN/EC OUT.

## 10 Reset button

The reset button is located beneath the top marking label on the bus coupler.

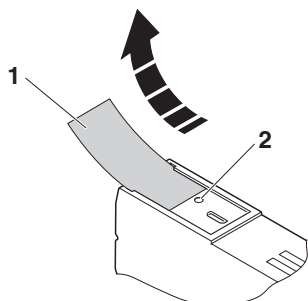

Figure 7 Reset button

- 1 Labeling field
- 2 Reset button

The reset button has the following functions:

- Restarting the bus coupler
- Resetting of the default settings

### 10.1 Restarting the bus coupler

The bus coupler is restarted when the button is pressed during operation.

The outputs of the station are set to the parameterized substitute values.

The process image of the inputs is not re-read.

### 10.2 Restoring the default settings

If you wish to restore the default settings, proceed as follows:

- Disconnect the power to the module.
- Press and hold the reset button.
- Switch on the power.
- When the RDY LED flashes red/green, release the button.

During the reset process the RDY LED lights up yellow.

When the bus coupler is fully started and ready to operate, the RDY LED lights up green.

## 11 Service interface

The service interface is located beneath the top marking field on the bus coupler.

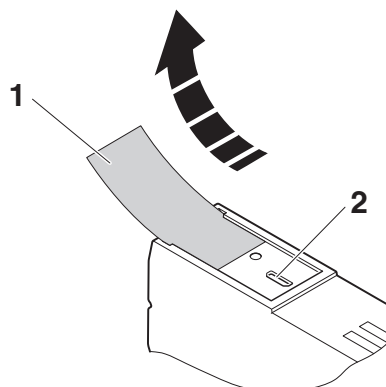

Figure 8 Service interface

- 1 Labeling field
- 2 Service interface

You can connect the bus coupler to a PC on which the Startup+ startup/diagnostic tool is running via USB using the service interface.

Startup+ offers the following functions:

- Parameterization of the station I/O modules
- I/O check
- Diagnostics



For detailed information on Startup+, please refer to the UM QS EN STARTUP+ user manual.

## 12 MAC address

A MAC address has already been assigned in preparation for a future firmware update with the function extension to EoE.

You can also use this MAC address for a firmware update via TFTP, see "Firmware update".

## 13 Parameter data

The CAN application protocol over EtherCAT® (CoE) mailbox protocol is the basis of the Modular Device Profile (MDP) and enables parameterization of EtherCAT® devices via the object dictionary. The object dictionary is accessed via CoE using Service Data Object (SDO) services.

Axioline F modules are parameterized via objects intended for this purpose in the CoE object dictionary. Each Axioline F module has two tunnel objects, via which the parameters can be set (object 20nn<sub>hex</sub>) and read (object 30nn<sub>hex</sub>). These tunnel objects can be used to parameterize the Axioline F modules in EtherCAT® system startup via the EtherCAT® engineering functionality of the StartUp or Init commands.

In the event of an error in the local bus, you can parameterize whether the local bus continues to run in the remaining system or whether it enters the stop state.

The objects implemented on the bus coupler are described in the "Object dictionary" section.

## 14 Substitute value behavior

If EtherCAT® communication fails or an error occurs in the local bus, all Axioline F station outputs are set to the parameterized substitute values.

## 15 Synchronizing the application

There are two modes for synchronizing the application which can be selected in the engineering system.

1. SM Synchronous
2. DC Synchronous

### 15.1 SM Synchronous

In this mode, the EtherCAT® communication system and the local bus operate asynchronously. The local bus is in Auto-Run mode and runs with the minimum possible cycle time for the current module configuration.

### 15.2 DC Synchronous

In this mode, the bus cycle of the local bus is synchronized to the EtherCAT® cycle.

The implemented distributed clock unit is used to synchronize the processes in a temporal manner.



If you want to use the DC Synchronous mode of the bus coupler, make sure that there is at least one module in the Axioline F station that supports local bus synchronization.

If you set DC Synchronous mode and there is no module in the Axioline F station that supports local bus synchronization, the bus coupler refuses the change in state from PRE-OP to SAFE-OP with "AL status code" 0028<sub>hex</sub> (SyncMode not supported).

The LEDs indicate this state:

LED	State	Meaning
<b>Bus coupler</b>		
RUN	Flashing slowly (2.5 Hz)	Bus coupler in Pre-Operational state
ERR	Flashing slowly (2.5 Hz)	Configuration error, a state transition initiated by the master cannot be executed
D	Green flashing	The station is ready for operation, communication within the station is OK. The data is <b>not</b> valid. Valid data from the controller/higher-level network not available. There is no fault in the module.
<b>Local bus device</b>		
D	Green flashing	Active

## Implementing DC Synchronous mode

In synchronous operation, the time points for outputting and reading process data from the individual I/O modules of the Axioline F station are synchronized with the higher-level network. This synchronization is by means of EtherCAT® Distributed Clocks (DC).

A requirement for this is that bus-synchronous operation is supported by the module. All modules that do not support bus-synchronous operation continue running asynchronously, as in SM Synchronous mode.

For information on which modules support bus-synchronous operation and the minimum cycle time that is possible, please refer to the module-specific documentation.

In general, with a preselected DC cycle time, only the I/O modules whose update rate (plus local bus cycle time) is less than the DC cycle time are operated synchronously. Only then do these I/O modules supply a new value in every DC cycle.

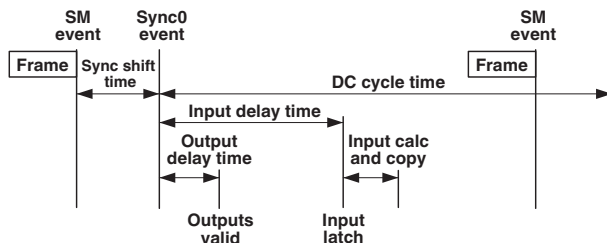

Figure 9 Synchronization model

The figure shows the synchronization model of the Axioline F bus coupler for EtherCAT®.

The so-called “DC Sync0 event” is used for synchronization. After the “Sync0 event” has occurred and a fixed delay time (output delay time) has elapsed, the process data is output. The inputs are likewise read after a fixed delay (input delay time).

The delay times depend on the Axioline F modules used as well as the size of the Axioline F station. They are calculated by the bus coupler during startup and are then constant.



Please observe the following when parameterizing the bus coupler for operation in DC Synchronous mode:

Select “Sync shift time”, i.e., the interval between “SM event” and “Sync0 event”, between 10% and 30% of the cycle time as far as possible.

The shortest EtherCAT® bus cycle must not be shorter than the maximum synchronization time of the modules located in the local bus that can be synchronized.



Object F102<sub>hex</sub> can be used to specify which modules of the local bus operate bus-synchronously (see “Objects for the status of bus-synchronous operation”).

## 16 Object dictionary

The bus coupler object dictionary contains objects which can be addressed via SDO services. These are defined in the ETG standards. Objects with a module-specific design are subsequently described in detail.

The objects are addressed using a combination of index and subindex. Subindex 0 lists the number of subindices.

The following applies for the tables below:

	Meaning	Representation	Numbering starts with
Length	Length of the elements in bytes		
Rights	Access rights		
R	Read		
W	Write		
nn	Number of the module addressed	Hexadecimal (hex)	00 for module 1
n	Number of the module addressed	Decimal (dec)	1 for module 1



Note the offset of 1 when counting the modules and the hexadecimal representation of the module number in the indices.

$$n_{\text{dec}} = nn_{\text{hex}} + 1$$

Examples:

Module in the local bus	$n_{\text{dez}}$	$nn_{\text{hex}}$
1	1	00
10	10	9
11	11	0A
33	33	20

## 16.1 CoE standard objects

Index (hex)	Name	Defined in standard
1000	Device type	ETG.1000.6
1008	Device name	ETG.1000.6
1009	Hardware version	ETG.1000.6
100A	Software version	ETG.1000.6
1018	Identify	ETG.1000.6
10F1	Error settings	ETG.1020
10F3	Diagnosis history	ETG.1020
10F8	Timestamp	ETG.1020
1C00	SyncManager type	ETG.1000.6
1C12	RxPDO assign	ETG.1000.6
1C13	TxPDO assign	ETG.1000.6
1C32	SM output parameter	ETG.1020
1C33	SM input parameter	ETG.1020
F000	Modular device profile	ETG.5001.1
F030	Configured module ident list	ETG.5001.1
F050	Detected module ident list	ETG.5001.1

ETG.1000.6 Application layer protocol specification

ETG.1020 EtherCAT® protocol enhancements

ETG.5001.1 Modular device profile part 1

## 16.2 Module-specific CoE objects

Index (hex)	Sub-index	Object name	Data type	Length	Rights	Meaning	
16nn	01	Module n RxPDO Mapping		4	R	Bit 31 ... bit 16	Index of the associated output data object (e.g., 7010 <sub>hex</sub> for module 2)
						Bit 15 ... bit 8	Subindex of the associated output data object
						Bit 7 ... bit 0	Subindex length of the associated output data object
1Ann	01	Module n TxPDO Mapping		4	R	Bit 31 ... bit 16	Index of the associated input data object (e.g., 6010 <sub>hex</sub> for module 2)
						Bit 15 ... bit 8	Subindex of the associated input data object
						Bit 7 ... bit 0	Subindex length of the associated input data object
6nn0	01	Module n Inputs	Octet string	Depending on module	R	n module input process data	
7nn0	01	Module n Outputs	Octet string	Depending on module	R	n module output process data	
9nn0		Module n Identification				Identification of module n	E.g., module 1: 9000 <sub>hex</sub> , module 2: 9010 <sub>hex</sub> etc.
	0A	Module ident	Unsigned 32	4	R	Unique number for module identification (connection to device description)	
	0B	Slot	Unsigned 16	2	R	Location of the module in the Axioline F station, beginning with 1	
Ann0		Module n DiagState				Diagnostics	Read access to PDI object 0018 <sub>hex</sub> in the Axioline F n module via the PDI channel
	01	No	Unsigned 16	2	R	Error number	See data sheet on the module.
	02	Prio	Unsigned 8	1	R	Priority	See data sheet on the module.
	03	Channel/group/module	Unsigned 8	1	R	Channel/group/module	See data sheet on the module.
	04	Code	Unsigned 16	2	R	Error code	See data sheet on the module.
	05	MoreFollows	Unsigned 8	1	R	More follows	See data sheet on the module.
	06	Text	Visible String	51	R	Text	See data sheet on the module.

### 16.3 CoE objects for identification (device rating plate)

PDI objects are stored on each Axioline F module for identification purposes. They contain information about the manufacturer and module and make up the device rating plate.

This information can be accessed using the bus coupler via EtherCAT®.

The following tables describe the detail on the device rating plate on objects in EtherCAT®.

#### Detail of manufacturer-specific information

Index (hex)	Sub-index	Object name	Data type	Length	Rights	Meaning (code in hex)	
9nn1		Module n Manufacturer Information				Detail of manufacturer-specific information from the PDI objects for identification (device rating plate)	
	01	VendorName	Visible String	15	R	0001	Vendor name
	02	Vendor ID	Visible String	6	R	0002	Vendor ID
	03	VendorText	Visible String	48	R	0003	Vendor text
	04	VendorURL	Visible String	29	R	0012	Vendor URL

#### Detail of module-specific information

Index (hex)	Sub-index	Object name	Data type	Length	Rights	Meaning (code in hex)	
9nn2		Module n Module Information				Detail of module-specific information from the PDI objects for identification (device rating plate)	
	01	ProductName	Visible String	Max. 58	R	0007	Product name
	02	Serial number	Visible String	11	R	0008	Serial number
	03	ProductText	Visible String	Max. 58	R	0009	Product text
	04	OrderNumber	Visible String	8	R	000A	Order No.
	05	HW BuildDate	Visible String	10	R	000B.1	Hardware version, date of version
	06	HW Version	Visible String	Max. 40	R	000B.2	Hardware version, version ID
	07	FW BuildDate	Visible String	10	R	000C.1	Firmware version, date of version
	08	FW Version	Visible String	Max. 40	R	000C.2	Firmware version, version ID
	09	PDI BuildDate	Visible String	10	R	000D.1	Parameter channel version, date of version
	0A	PDI Version	Visible String	Max. 40	R	000D.2	Parameter channel version, version ID
	0B	DeviceType	Octet string	8	R	0037	Device type

#### 16.4 Objects for access to PDI objects (tunnel objects)

Parameter and diagnostic data as well as other information is transmitted as objects via the PDI channel of the AxioLine F station.

You can access the PDI objects of the modules of a station via EtherCAT<sup>®</sup>. Objects  $20n_{hex}$  and  $30n_{hex}$  are used, with which a tunnel method can be implemented.

Index (hex)	Sub-index	Object name	Data type	Length	Rights	Meaning	
20nn		Module n PDI Write Tunnel				Write access to the PDI objects in AxioLine F module n via the PDI channel Mapping to PDI write service (service code $01_{hex}$ ) at slot n	
	01	Command	Octet string	250	R/W	Data for the PDI write request	
						Byte 0	Subslot
						Byte 1, 2	PDI object index
						Byte 3	PDI object subindex
						Byte 4	Length of the data to be written
						Byte 5 ... n	User data (max. 245 bytes)
	02	Status	Unsigned 8	1	R	Status of the last write access	
						$01_{hex}$	Last access completed successfully (positive confirmation received)
						$03_{hex}$	Last access not completed successfully (negative confirmation received)
	03	Response	Octet string	9	R	Result of the last write access Data for PDI write response	
						Byte 0	Subslot
						Byte 1, 2	PDI object index
						Byte 3	PDI object subindex
						Byte 4	Length (= 0)
Positive confirmation							
Byte 5 ... 8						0	
Negative confirmation							
Byte 5						Error class	
Byte 6	Error code						
Byte 7, 8		Additional error code					



For the meaning of the error message in Error class, Error code, and Additional error code, please refer to the UM EN AXL F SYS DIAG user manual.

Index (hex)	Sub-index	Object name	Data type	Length	Rights	Meaning		
30nn		Modul n PDI Read Tunnel				Read access to PDI objects in Axioline F module n via the PDI channel Mapping to PDI read service (service code 00 <sub>hex</sub> ) at slot n		
	01	Command	Octet string	4	R/W	Data for PDI read request		
						Byte 0	Subslot	
						Byte 1, 2	PDI object index	
							Byte 3	PDI object subindex
	02	Status	Unsigned 8	1	R	Status of the last read access		
						01 <sub>hex</sub>	Last access completed successfully (positive confirmation received)	
						03 <sub>hex</sub>	Last access not completed successfully (negative confirmation received)	
	03	Response	Octet string	250	R	Result of the last read access Data for PDI read response		
						Byte 0	Subslot	
						Byte 1, 2	PDI object index	
						Byte 3	PDI object subindex	
						Byte 4	Length	
Positive confirmation								
Byte 5, 6						0		
Byte 7 ... n						Data for PDI read response		
Negative confirmation								
Byte 5						Error class		
Byte 6	Error code							
Byte 7, 8	Additional error code							



For the meaning of the error message in Error class, Error code, and Additional error code, please refer to the UM EN AXL F SYS DIAG user manual.

## 16.5 Objects for Axioline F bus diagnostics

### 16.5.1 F100<sub>hex</sub>: Local bus diag info

CoE object F100<sub>hex</sub> can be used to request the status information of the Axioline F master.

Index (hex)	Sub-index	Object name	Data type	Length	Rights	Meaning
F100		Bus coupler diag info				Read access to diagnostic information of the Axioline F master
	01	Bus state	Unsigned 16	2	R	Current state of the Axioline F local bus
	02	Error_Code	Unsigned 16	2	R	Error code according to the current bus state
	03	Add_Error_Info	Unsigned 16	2	R	Additional error information

“Bus state” mirrors the diagnostic status register. For more detailed information on this, please refer to the UM EN AXL F SYS DIAG user manual.

“Error\_Code” indicates the error code of module errors. For the meaning of the error code, please refer to the data sheet for the module in question or the UM EN AXL F SYS DIAG user manual.

“Add\_Error Info” indicates the position of the module in question.

The data for object F100<sub>hex</sub> is additionally provided in the cyclic input data of the Axioline F station (see also “Process data of the bus coupler”).

## 16.6 Objects for the status of bus-synchronous operation

This object contains information about which local bus modules operate bus-synchronously.

Index (hex)	Sub-index	Object name	Data type	Length	Rights	Meaning
F102		Modules used in synchronization				During operation in DC Synchronous mode, indicates which Axioline F modules are operated bus-synchronously
	01		Unsigned 8	1	R	Position of the modules that are operated bus-synchronously in the local bus starting with 1; $n \leq 63$
	...		Unsigned 8	1	R	
	n		Unsigned 8	1	R	

## 16.7 Objects for bus coupler configuration

The bus coupler has objects which are used for the configuration of the bus coupler. Write access to these objects is only possible in the PREOP state.

The contents of the objects are stored retentively in the bus coupler and are therefore still available after the bus coupler is restarted.

When reset to the default settings, these objects return to their default values.

Object F800<sub>hex</sub> can be used to configure the byte sequence of the transmitted process data.

Index (hex)	Sub-index	Object name	Data type	Length	Rights	Meaning				
F800		Endian settings				Byte sequence setting for a process data length of 16, 32 or 64 bits. The EtherCAT® standard specifies Little Endian format, Axioline F uses Big Endian.				
	01	Swap Word	Boolean	0.1	R, R/W in PreOP	Byte sequence for a process data length of 16 bits <table border="1"> <tr> <td>True</td> <td>Little endian (Default)</td> </tr> <tr> <td>False</td> <td>Big endian</td> </tr> </table>	True	Little endian (Default)	False	Big endian
True	Little endian (Default)									
False	Big endian									
	02	Swap DWord	Boolean	0.1	R, R/W in PreOP	Byte sequence for a process data length of 32 bits <table border="1"> <tr> <td>True</td> <td>Little endian (Default)</td> </tr> <tr> <td>False</td> <td>Big endian</td> </tr> </table>	True	Little endian (Default)	False	Big endian
True	Little endian (Default)									
False	Big endian									
	03	Swap LWord	Boolean	0.1	R, R/W in PreOP	Byte sequence for a process data length of 64 bits <table border="1"> <tr> <td>True</td> <td>Little endian (Default)</td> </tr> <tr> <td>False</td> <td>Big endian</td> </tr> </table>	True	Little endian (Default)	False	Big endian
True	Little endian (Default)									
False	Big endian									

Object F801<sub>hex</sub> can be used to specify the bus coupler response in the event of a bus error.

Index (hex)	Sub-index	Object name	Data type	Length	Rights	Meaning				
F801		Leave OP on busfail				Parameterization of the response to an Axioline F bus error				
	00		Boolean	0.1	R, R/W in PreOP	<table border="1"> <tr> <td>True</td> <td>In the event of an Axioline F bus error, the bus coupler switches to the SAFEOP ERR state, in addition a diagnosis is entered.</td> </tr> <tr> <td>False</td> <td>(Default) In the event of an Axioline F bus error, the bus coupler remains in the OP state, only a diagnosis is entered.</td> </tr> </table>	True	In the event of an Axioline F bus error, the bus coupler switches to the SAFEOP ERR state, in addition a diagnosis is entered.	False	(Default) In the event of an Axioline F bus error, the bus coupler remains in the OP state, only a diagnosis is entered.
True	In the event of an Axioline F bus error, the bus coupler switches to the SAFEOP ERR state, in addition a diagnosis is entered.									
False	(Default) In the event of an Axioline F bus error, the bus coupler remains in the OP state, only a diagnosis is entered.									

Object F802<sub>hex</sub> can be used to check the connected module configuration.

Index (hex)	Sub-index	Object name	Data type	Length	Rights	Meaning				
F802		Validate module configuration				Validation of the module configuration				
	00		Boolean	0.1	R, R/W in PreOP	<table border="1"> <tr> <td>True</td> <td>(Default) During the transition from PREOP to SAFEOP, the bus coupler checks the module configuration.</td> </tr> <tr> <td>False</td> <td>The bus coupler does not check the module configuration.</td> </tr> </table>	True	(Default) During the transition from PREOP to SAFEOP, the bus coupler checks the module configuration.	False	The bus coupler does not check the module configuration.
True	(Default) During the transition from PREOP to SAFEOP, the bus coupler checks the module configuration.									
False	The bus coupler does not check the module configuration.									

In order for the module configuration to be checked, the master must write object F030<sub>hex</sub> with the expected module configuration during the state transition from PREOP to SAFEOP. If this is not done, validation is not carried out. When the object is written, it must be done so correctly and consistently. The contents of object F030<sub>hex</sub> are reset on a state transition from SAFEOP to PREOP.

You can read the cycle time of the local bus with the object F803<sub>hex</sub>.

Index (hex)	Sub-index	Object name	Data type	Length	Rights	Meaning
F803	00	Bus cycletime	Unsigned 32	4	R	Local bus cycle time displayed in nanoseconds (ns)

## 17 Process data

### 17.1 Process data of the bus coupler

In addition to the cyclic IN and OUT process data, which is defined by the connected AxioLine F modules, the bus coupler itself has data which is inserted in the cyclic process image. This data has a total length of 8 bytes.

In accordance with the EtherCAT<sup>®</sup> standard, this data appears before the IN process data of the first AxioLine F module in the process image (SyncManager 3 bytes 0 ... 7). The objects for the corresponding PDO mapping can be found in 1AFF<sub>hex</sub>.

Process data byte 0 and 1 (word 0) are assigned the “New messages available” bit (index 10F3<sub>hex</sub>, subindex 04) of the “Diagnosis history” object.

Process data words 1 ... 3 contain status and diagnostic information for the AxioLine F bus coupler and can also be called via acyclic services using CoE. They appear in the form of object F100<sub>hex</sub>.

Word 0, byte 0							
7	6	5	4	3	2	1	0
Reserved							New Diagnosis Message

Word 0, byte 1							
7	6	5	4	3	2	1	0
Reserved							

Word 1			
Byte 3		Byte 2	
Localbus bus state			

Word 2			
Byte 5		Byte 4	
Local bus Error_Code			

Word 3			
Byte 7		Byte 6	
Local bus Add_Error Info			

“Local bus bus state” mirrors the diagnostic status register. For more detailed information on this, please refer to the UM EN AXL F SYS DIAG user manual.

“Local bus Error\_Code” indicates the error code of module errors. For the meaning of the error code, please refer to the data sheet for the module in question or the UM EN AXL F SYS DIAG user manual.

“Local bus Add\_Error Info” indicates the position of the module in question.

### 17.2 Process data of the local bus modules

The IN and OUT process data of the modules appear according to their process data description (PDI objects 003B<sub>hex</sub> and 003C<sub>hex</sub> on the module).

For mapping, object F800<sub>hex</sub> can be used to configure whether process data with a length of 16, 32, and 64 bits is to be transmitted in Big Endian format (AxioLine F standard) or in Little Endian format. The configuration is stored retentively in the bus coupler.

## 18 Diagnostics strategy

### 18.1 Mechanisms

Different mechanisms are used to diagnose the bus coupler.

Mechanism	Diagnostics
EtherCAT <sup>®</sup> state machine	EtherCAT <sup>®</sup> system diagnostics
EtherCAT <sup>®</sup> hardware watchdog	
Emergency messages	Errors are indicated to the master
Diagnostic objects in the CoE object dictionary	Advanced diagnostics, e.g., of I/O errors
10F1	Error settings
F100	Bus coupler diag info
F101	Bus error counters
F102	Modules used in synchronization
F802	Validate module configuration
Diagnosis history object	16 diagnostic messages could not be stored
10F3	Diagnosis history

### 18.2 EtherCAT<sup>®</sup> state machine

An error is indicated as follows:

- Error bit in the “AL status code” register is set.
- An error code is written in the “AL status code” register by the slave.

The following codes are implemented on the bus coupler:

AL status code (hex)	Meaning
0000	No error: There is no error.
0011	Invalid requested state change: The state change requested is invalid.
0012	Unknown requested state: The state requested does not exist.
0016	Invalid mailbox configuration: Error when configuring the SyncManager for mailbox communication.
001A	Multiple synchronization error: Recurring synchronization error. Master communication faulty.
001B	SyncManager watchdog: The hardware watchdog which monitors the SyncManager process data has expired.
001D	Invalid output configuration: Error in the SyncManager configuration for output process data.
001E	Invalid input configuration: Error in the SyncManager configuration for input process data.
0028	SyncMode not supported: There is no module in the Axioline F station that supports local bus synchronization.
002B	No valid inputs or outputs: Process data invalid. Error in the local bus.
002C	Fatal synch error: SYNCH_0 event cannot be generated. DC configuration faulty.
0032	PLL error: Synchronization not possible. Master jittering too high or DC configuration faulty.
0070	Detected module ident list does not match: The configured module list (F030 <sub>hex</sub> ) does not match the detected module list (F050 <sub>hex</sub> ).

### 18.3 Emergency messages

Emergency messages are an unverified service based on CoE. As such, all errors can be indicated to the master by the slave, taking the form of messages which are specified in ETG.1000.6.

Detail of Axioline F bus and I/O errors on a CoE emergency message:

CoE emergency message	2 bytes	1 byte	5 bytes			
	Error code	Error reg	Data			
Axioline F bus errors	2 bytes	1 byte	2 bytes	2 bytes		1 byte
	1000 <sub>hex</sub>	80 <sub>hex</sub>	Slot number	Error code		0
Axioline F I/O errors	2 bytes	1 byte	2 bytes	1 byte	1 byte	1 byte
	Error code	80 <sub>hex</sub>	Slot number	Location	Priority	0

#### CoE emergency message

Error code (hex)	Meaning
00xx	Error reset or no error
10xx	Generic error
20xx	Current
21xx	Current, device input side
22xx	Current inside the device
23xx	Current, device output side
30xx	Voltage
31xx	Mains voltage
32xx	Voltage inside the device
33xx	Output voltage
40xx	Temperature
41xx	Ambient temperature
42xx	Device temperature
50xx	Device hardware
60xx	Device software
61xx	Internal software
62xx	User software
63xx	Data set
70xx	Additional modules
80xx	Monitoring
81xx	Communication
82xx	Protocol error
8210	PDO not processed due to length error
8220	PDO length exceeded
90xx	External error
A0xx	ESM transition error
F0xx	Additional functions
FFxx	Device specific

The errors which could occur in the Axioline F system are separated into two groups with different message designs.

#### Axioline F I/O errors

For the error codes for Axioline F I/O errors, please refer to the data sheets for the I/O modules.

#### Axioline F bus errors

The error codes for Axioline F bus errors have the emergency error code 1000<sub>hex</sub> (generic error) as standard.

The Axioline F error code is displayed in the "Emergency message" data area.



For the meaning of the error codes for the Axioline F bus errors and Axioline F I/O errors, please refer to the AXL F SYS DIAG user manual.

#### 18.4 Diagnosis history 10F3<sub>hex</sub>

The object 10F3<sub>hex</sub> is implemented as a ring memory in Overwrite mode. The last 16 diagnostic messages are always stored; older messages are deleted.

The error codes of the Axioline F bus and I/O errors are stored in the object's diagnostic messages.

The following table shows the design of a diagnostic message from the Axioline F bus coupler for EtherCAT® as well as detailing specific Axioline F information.

Index (hex)	Sub-index	Object name	Data type	Length	Rights	Meaning
10F3		Diagnosis history				Diagnostic statistics
	01	Maximum messages	Unsigned 8	1	R	Maximum number of messages
	02	Newest message	Unsigned 8	1	R	Newest message
	03	Newest acknowledged message	Unsigned 8	1	R/W	Newest acknowledged message Writing a "0" deletes the message from the ring memory.
	04	New messages available	Boolean	0.1	R	New message present
	05	Flags	Unsigned 16	2	R/W	Setting for the behavior of the object. See ETG.1020

#### 18.5 Diagnostic objects in the CoE object dictionary

The Diagnosis History Object enables a diagnosis station-wide.

For module-specific diagnostics, the module diagnostics objects (PDI object 0018<sub>hex</sub>) are displayed in the CoE object dictionary of the bus coupler (CoE objects A000<sub>hex</sub> to A3F0<sub>hex</sub>).

## 19 Firmware update

It is possible to carry out a firmware update via EtherCAT®. The File Access over EtherCAT® (FoE) mechanism is used for this, which is provided via your engineering system.

For detailed instructions for the firmware update with TwinCAT®, please refer to application note AH EN FIRMWARE UPDATE AXL F BK EC / IL EC BK-PAC.

The current file for updating the firmware as well as the application note are available to download at the following address: [phoenixcontact.net/product/2688899](http://phoenixcontact.net/product/2688899).



If you were unable to update via FoE, you can perform an update via TFTP using the printed MAC address.

For detailed instructions for firmware update via the TFTP protocol, please refer to application note AH EN TFTP FIRMWARE UPDATE AXL F BK.



**NOTE: Access to incorrect data when using a project that has not been adapted**

The data of object F100<sub>hex</sub> is mapped in the process image before the IN process data of the first Axioline F module.

If an existing project is used without adapting it, you will access incorrect data due to the shift of the IN process data.

Therefore, adapt an existing project accordingly.



Only the firmware changes that result in a significant extension to the functions are listed here.

An overview of the content of all firmware changes is to be found in the "Change notes" file in the zip file with the firmware update.

### Key changes in the firmware versions

#### Firmware 1.10

Full implementation of DC Synchronous mode

Addition of the following CoE objects (hex):

10F1	Error settings
10F8	Timestamp
F100	Bus coupler diag info
F101	Bus error counters
F102	Modules used in synchronization
F800	Endian settings
F801	Leave OP on busfail
F802	Validate module configuration

Modified object

10F3	Diagnosis history
------	-------------------

The data for object F100<sub>hex</sub> is additionally provided in the cyclic input data of the Axioline F station (see also "Process data of the bus coupler").



# SCATTERGOOD & JOHNSON LTD

ELECTRICAL ENGINEERING & FLUID CONTROL DISTRIBUTORS

Est.1899

At Scattergood & Johnson Ltd, we pride ourselves on being a technical distributor to specialist industries.

Working with a range of quality product suppliers across a number of specialist markets, we are not your average 'box shifter' - we are your technical and supply chain partner.

We fully support every product we sell - for free! Our internal team and external sales engineers can answer any product or application question, no matter the complexity.

Backing up this technical ability is a range of 50,000+ products available from stock for nationwide next day delivery (same day if required!), or you can collect what you need from any of our trade counters around the UK.

Select your specialist interest below to learn more about how we can help.

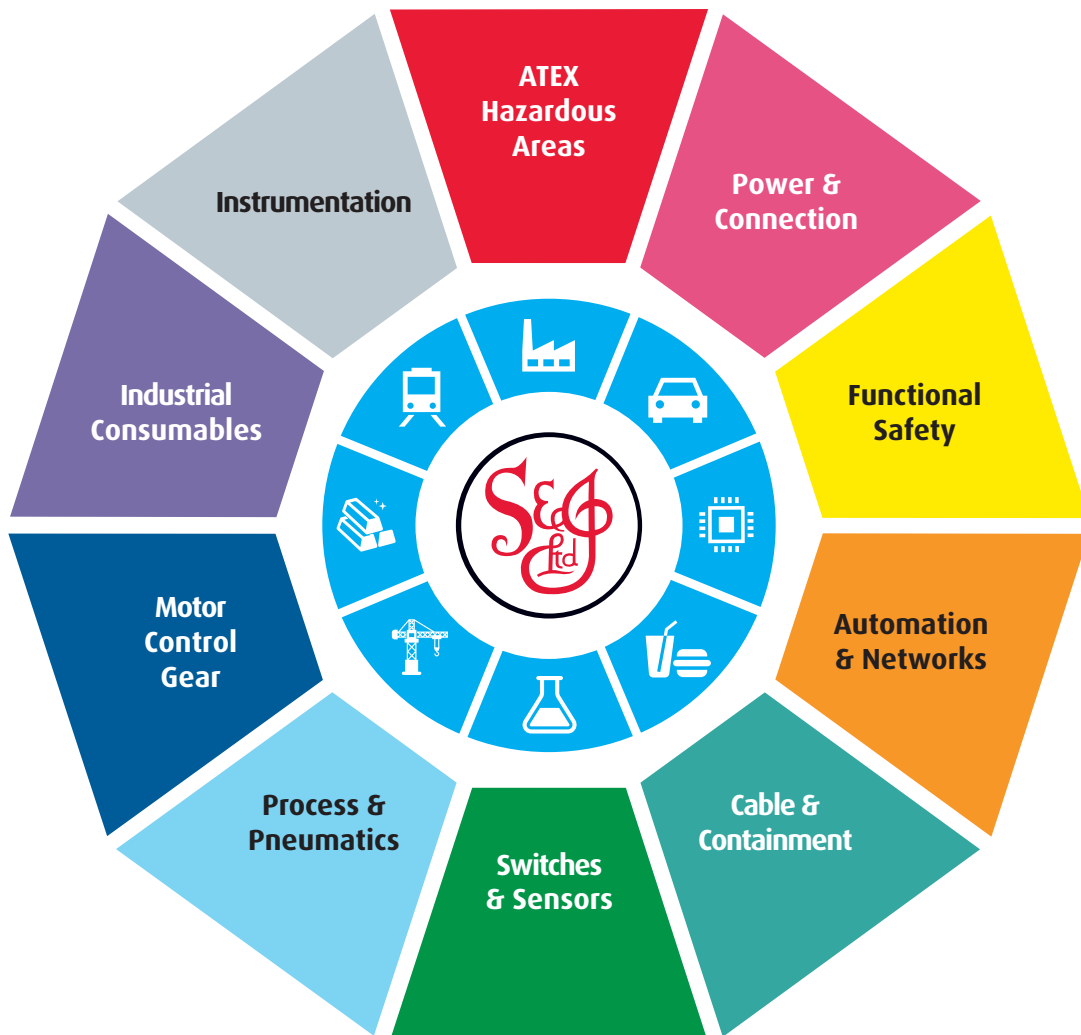

Online, In Branch and On the Road - Scattergood & Johnson Ltd, there when you need us.

# [www.scatts.co.uk](http://www.scatts.co.uk)