

# IL PB BK DI8 DO4/EF-PAC

**Inline bus coupler for PROFIBUS DP with 8 digital inputs and 4 digital outputs**



Data sheet  
7724\_en\_05

© PHOENIX CONTACT 2017-03-30

## 1 Description

The bus coupler with integrated I/Os is intended for use within a PROFIBUS network and represents the link to the Inline I/O system.

Up to 61 Inline devices can be connected to the bus coupler. A corresponding GSD file is available for integrating the Inline station into the programming system.

This file can be downloaded via the product at [phoenixcontact.net/products](http://phoenixcontact.net/products).

### Features

- PROFIBUS connection via 9-pos. D-SUB socket
- Electrical isolation between PROFIBUS interface and logic
- 8 digital inputs, 4 digital outputs onboard
- Connection of a maximum of 16 PCP devices
- DP/V1 for class 1 and class 2 masters
- PROFIBUS data transmission speed of 9.6 kbps to 12 Mbps
- Rotary coding switches for setting the PROFIBUS address
- Supported PROFIBUS addresses from 0 to 126
- I&M functions
- IO-Link call (firmware 2.0 or later)
- Operation of PROFIsafe devices
- Hardware version 01 or later:
- Approved for use in zone 2 potentially explosive areas



**WARNING: Explosion hazard when used in potentially explosive areas**

When using the terminal in potentially explosive areas, observe the corresponding notes.



This data sheet is only valid in association with the IL SYS INST UM E user manual.



Make sure you always use the latest documentation.

It can be downloaded from the product at [phoenixcontact.net/products](http://phoenixcontact.net/products).

---

<b>2</b>	<b>Table of contents</b>	
1	Description .....	1
2	Table of contents .....	2
3	Ordering data .....	3
4	Technical data .....	5
5	Internal circuit diagram .....	10
6	Notes on using the terminal block in potentially explosive areas .....	11
7	Connection of PROFIBUS, power supply, actuators, and sensors .....	12
	7.1 Connecting PROFIBUS .....	12
	7.2 Mains termination resistors .....	12
	7.3 Hardware configuration .....	12
	7.4 Terminal point assignment of input and output connectors .....	13
8	Connection example.....	13
9	Local status and diagnostic indicators .....	14
10	Process data.....	15
11	Parameter data .....	15
12	Firmware functions .....	16
13	IO-Link.....	17
14	Notes on using the bus coupler in a PROFI-safe system .....	18
15	Additional documentation .....	18

### 3 Ordering data

Description	Type	Order No.	Pcs./Pkt.
Inline, Bus coupler, PROFIBUS DP, D-SUB-9 female connector, Digital inputs: 8, 24 V DC, Connection technology: 3-conductor, Digital outputs: 4, 24 V DC, 500 mA, Connection technology: 3-conductor, Transmission speed in the local bus 500 kbps / 2 Mbps, Degree of protection IP20, including Inline connectors and marking fields	IL PB BK DI8 DO4/EF-PAC	2692322	1
Accessories	Type	Order No.	Pcs./Pkt.
Quick mounting end clamp for NS 35/7,5 DIN rail or NS 35/15 DIN rail, with marking option, width: 9.5 mm, color: gray (Assembly)	CLIPFIX 35	3022218	50
Quick mounting end clamp for NS 35/7,5 DIN rail or NS 35/15 DIN rail, with marking option, with parking option for FBS...5, FBS...6, KSS 5, KSS 6, width: 5.15 mm, color: gray (Assembly)	CLIPFIX 35-5	3022276	50
Insert strip, Sheet, white, unlabeled, can be labeled with: Office printing systems, CMS-P1-PLOTTER: Laser printer, Mounting type: Insert, Lettering field: 62 x 46 mm (Marking)	ESL 62X46	0809502	5
Labeling field, width: 48.8 mm (Marking)	IB IL FIELD 8	2727515	10
Insert strip, Sheet, white, unlabeled, can be labeled with: Office printing systems, CMS-P1-PLOTTER: Laser printer, Mounting type: Insert, Lettering field: 62 x 10 mm (Marking)	ESL 62X10	0809492	1
Labeling field, width: 12.2 mm (Marking)	IB IL FIELD 2	2727501	10
Connector set, for Inline bus coupler with I/Os mounted in rows (Connector/Adapter)	IL BKDIO-PLSET	2878599	1
Connector, color coded, for digital 4, or 16-channel Inline input terminals (Connector/Adapter)	IB IL SCN-12-ICP	2727611	10
Connector, colored identification, for digital 4, or 16-channel Inline output terminal blocks (Connector/Adapter)	IB IL SCN-12-OCP	2727624	10
D-SUB plug, 9-pos., pin, axial version with two cable entries, below 35°, bus system: PROFIBUS DP up to 12 Mbps, termination resistor can be switched on via slide switch, pin assignment: 3, 5, 6, 8; spring-cage connection terminal blocks (Connector/Adapter)	SUBCON-PLUS-PROFIB	2744348	1
D-SUB connector, 9-pos., male connector, cable entry < 35°, bus system: PROFIBUS DP up to 12 Mbps, termination resistor can be switched on via slide switch, pin assignment: 3, 5, 6, 8; screw connection terminal blocks (Connector/Adapter)	SUBCON-PLUS-PROFIB/SC2	2708232	1

Accessories	Type	Order No.	Pcs./Pkt.
D-SUB connector, 9-pos., male connector, cable entry < 35°, bus system: PROFIBUS DP up to 12 Mbps with PG D-SUB socket for connecting a programming device, termination resistor can be switched on via slide switch, pin assignment: 3, 5, 6, 8; screw connection terminal blocks (Connector/Adapter)	SUBCON-PLUS-PROFIB/PG/SC2	2708245	1
D-SUB connector, 9-pos., male connector, cable entry < 90°, bus system: PROFIBUS DP up to 12 Mbps, termination resistor can be switched on via slide switch, pin assignment: 3, 5, 6, 8; IDC terminal block connection (Connector/Adapter)	SUBCON-PLUS-PROFIB/90/IDC	2313672	1
D-SUB connector, 9-pos., male connector, cable entry < 90°, bus system: PROFIBUS DP up to 12 Mbps with PG D-SUB socket for connecting a programming device, termination resistor can be switched on via slide switch, pin assignment: 3, 5, 6, 8; IDC terminal block connection (Connector/Adapter)	SUBCON-PLUS-PROFIB/90/PG/IDC	2313685	1
D-SUB connector, 9-pos., male connector, cable entry < 90°, bus system: PROFIBUS DP up to 12 Mbps, termination resistor can be switched on via slide switch, pin assignment: 3, 5, 6, 8; screw connection terminal blocks (Connector/Adapter)	SUBCON-PLUS-PROFIB/90/SC	2313698	1
D-SUB connector, 9-pos., male connector, cable entry < 90°, bus system: PROFIBUS DP up to 12 Mbps with PG D-SUB socket for connecting a programming device, termination resistor can be switched on via slide switch, pin assignment: 3, 5, 6, 8; screw connection terminal blocks (Connector/Adapter)	SUBCON-PLUS-PROFIB/90/PG/SC	2313708	1
D-SUB connector, 9-pos., male connector, axial version with two cable entries, bus system: PROFIBUS DP up to 12 Mbps, termination resistor can be switched on via slide switch, pin assignment: 3, 5, 6, 8; screw connection terminal blocks (Connector/Adapter)	SUBCON-PLUS-PROFIB/AX/SC	2744380	1
D-SUB plug, 9-pos., pin, assignment: 3, 5, 6, 8; two M12 cable glands (B-coded) under 35°. Bus system: PROFIBUS DP up to 12 Mbps. Termination resistor via separate M12 terminator. (Connector/Adapter)	SUBCON-PLUS-PROFIB/35/M12	2902320	1
D-SUB plug, 9-pos., pin, assignment: 3, 5, 6, 8; two M12 cable glands (B-coded) under 90°. Bus system: PROFIBUS DP up to 12 Mbps. Termination resistor via separate M12 terminator. (Connector/Adapter)	SUBCON-PLUS-PROFIB/90/M12	2902318	1

Documentation	Type	Order No.	Pcs./Pkt.
User manual, English, Automation terminals of the Inline product range	IL SYS INST UM E	-	-
User manual, English, Diagnostic and firmware functions of the IL PB BK DI8 DO4/EF-PAC bus coupler	UM EN IL PB BK DI8 DO4/EF-PAC	-	-
Quick start guide, English, configuring Inline modules with safe inputs or outputs under PROFIsafe on a SIMATIC® S7 controller	UM QS DE IB IL 24 PSDX - S7	-	-
Application note, English, Inline terminals for use in zone 2 potentially explosive areas	AH EN IL EX ZONE 2	-	-
Application note, German/English, I/O modules at bus couplers	AH IL BK IO LIST	-	-
Application note, English, Parameter data length for devices in a PROFIBUS system	AH EN PROFIBUS PARAMETER DATA	-	-

## 4 Technical data

### Dimensions (nominal sizes in mm)

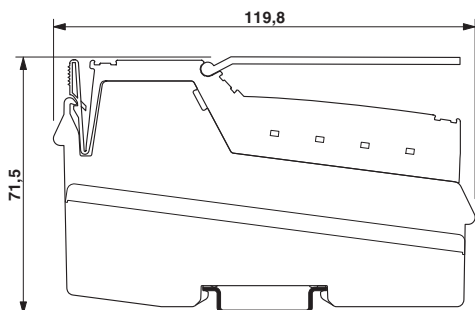

Width	80 mm
Height	119.8 mm
Depth	71.5 mm
Note on dimensions	Specifications with connectors

<b>General data</b>	
Color	green
Weight	320 g (with connectors)
Ambient temperature (operation)	-25 °C ... 60 °C
Ambient temperature (storage/transport)	-25 °C ... 85 °C
Permissible humidity (operation)	10 % ... 95 % (non-condensing)
Permissible humidity (storage/transport)	10 % ... 95 % (non-condensing)
Air pressure (operation)	70 kPa ... 106 kPa (up to 3000 m above sea level)
Air pressure (storage/transport)	70 kPa ... 106 kPa (up to 3000 m above sea level)
Degree of protection	IP20
Protection class	III, IEC 61140, EN 61140, VDE 0140-1
<b>Connection data</b>	
Designation	Inline connector
Connection method	Spring-cage connection
Conductor cross section solid / stranded	0.08 mm <sup>2</sup> ... 1.5 mm <sup>2</sup> / 0.08 mm <sup>2</sup> ... 1.5 mm <sup>2</sup>
Conductor cross section [AWG]	28 ... 16
Stripping length	8 mm
<b>Connection data for UL approvals</b>	
Designation	Inline connector
Connection method	Spring-cage connection
Conductor cross section solid / stranded	0.2 mm <sup>2</sup> ... 1.5 mm <sup>2</sup> / 0.2 mm <sup>2</sup> ... 1.5 mm <sup>2</sup>
Conductor cross section [AWG]	24 ... 16
Stripping length	8 mm
<b>Interface PROFIBUS DP</b>	
Number	1
Connection method	D-SUB-9 female connector
Number of positions	9
Transmission speed	9.6 kbps ... 12 Mbps
<b>Interface Inline local bus</b>	
Connection method	Inline data jumper
Transmission speed	500 kbps / 2 Mbps (Automatic detection, no combined system)

**System limits of the bus coupler**

Amount of process data	max. 488 Byte (per station) max. 244 Byte (Input) max. 244 Byte (Output)
Number of parameter data	max. 244 Byte (including 14 bytes for the bus coupler, DP/V1, and the local inputs and outputs)
Number of configuration data	max. 244 Byte (including 5 bytes for the local inputs and outputs)
IN and OUT process data for I/O modules that can be aligned	486 Byte
IN process data for I/O modules that can be aligned	243 Byte
OUT process data for I/O modules that can be aligned	243 Byte
Parameter data for connectable I/O modules	230 Byte
Configuration data for I/O modules that can be aligned	239 Byte
Number of supported devices	max. 63 (per station)
Number of local bus devices that can be connected	max. 61 (on board I/Os are two devices)
Number of devices with parameter channel	max. 16
Number of supported branch terminals with remote bus branch	0
Response time of I/Os	typ. 4 ms (aligned I/Os; transmission speed: PROFIBUS 1.5 Mbps, local bus 500 kbps)



Observe the logic current consumption of each device when configuring an Inline station! It is specified in every terminal-specific data sheet. The current consumption can differ depending on the individual terminal. The permissible number of devices that can be connected therefore depends on the specific station structure.

**Power supply for module electronics**

Connection method	Spring-cage connection
Designation	Bus coupler supply $U_{BC}$ ; Communications power $U_L$ (7.5 V) and the analog supply $U_{ANA}$ (24 V) are generated from the bus coupler supply.
Supply voltage	24 V DC (via Inline connector)
Supply voltage range	19.2 V DC ... 30 V DC (including all tolerances, including ripple)
Current consumption	max. 0.98 A (from $U_{BK}$ )
Power dissipation	typ. 1.7 W (entire device)

**Power consumption****NOTE: Electronics may be damaged when overloaded**

Provide external fuses for the 24 V areas  $U_{BK}$ ,  $U_M$ , and  $U_S$ . The power supply unit must be able to supply four times the nominal current of the external fuse, to ensure that it trips in the event of an error.

Main circuit supply $U_M$	24 V DC
Supply voltage range $U_M$	19.2 V DC ... 30 V DC (including all tolerances, including ripple)
Power supply at $U_M$	max. 8 A DC (Sum of $U_M + U_S$ )
Current consumption from $U_M$	max. 8 A DC
Segment circuit supply $U_S$	24 V DC
Supply voltage range $U_S$	19.2 V DC ... 30 V DC (including all tolerances, including ripple)
Power supply at $U_S$	max. 8 A DC (Sum of $U_M + U_S$ )
Current consumption from $U_S$	max. 8 A DC
Communications power $U_L$	7.5 V DC $\pm 5\%$
Power supply at $U_L$	max. 0.8 A DC
I/O supply voltage $U_{ANA}$	24 V DC
Supply voltage range $U_{ANA}$	19.2 V DC ... 30 V DC (including all tolerances, including ripple)
Power supply at $U_{ANA}$	max. 0.5 A DC

**Digital inputs**

Number of inputs	8
Connection method	Inline connector
Connection technology	3-conductor
Description of the input	EN 61131-2 type 1
Nominal input voltage	24 V DC
Nominal input current	typ. 3 mA
Current flow	Limited to 3 mA, maximum
Input voltage range "0" signal	-30 V DC ... 5 V DC
Input voltage range "1" signal	15 V DC ... 30 V DC
Delay at signal change from 0 to 1	typ. 2.9 ms
Delay at signal change from 1 to 0	typ. 2.9 ms
Permissible conductor length to the sensor	100 m
Reverse polarity protection	Suppressor diode

**Digital outputs**

Number of outputs	4
Connection method	Inline connector
Connection technology	3-conductor
Nominal output voltage	24 V DC
Voltage difference with nominal current	< 1 V
Maximum output current per channel	500 mA
Maximum output current per device	2 A

<b>Digital outputs</b>	
Nominal load, ohmic	12 W
Nominal load, inductive	12 VA (1.2 H, 48 Ω)
Nominal load, lamp	12 W
Signal delay	typ. 2.9 ms
Maximum operating frequency with inductive nominal load	0.5 Hz (1.2 H, 48 Ω)
Behavior at voltage switch-off	The output follows the power supply without delay
Limitation of the voltage induced on circuit interruption	approx. -30 V
Output current when switched off	max. 10 μA (When not loaded, a voltage can be measured even at an output that is not set.)
Behavior with overload	Auto restart
Behavior with inductive overload	Output can be destroyed
Reverse voltage resistance to short pulses	Reverse voltage proof
Resistance to permanent reverse voltage	max. 2 A
Overcurrent shut-down	min. 0.7 A
Short-circuit and overload protection	Free running circuit In output driver
<b>Configuration data</b>	
ID number	0B50
Input address area	2 Byte (or 1 byte, selection in the GSD file)
Output address area	2 Byte (or 1 byte, selection in the GSD file)
<b>Error messages to the higher level control or computer system</b>	
Short-circuit / overload of the digital outputs	Yes
Sensor supply failure	Yes
Failure of the actuator supply	Yes
<b>Mechanical tests</b>	
Vibration resistance in acc. with EN 60068-2-6/ IEC 60068-2-6	5g
Shock in acc. with EN 60068-2-27/IEC 60068-2-27	Operation: 25g, 11 ms duration, semi-sinusoidal shock impulse
<b>Conformance with EMC Directive 2014/30/EU</b>	
<b>Noise immunity test in accordance with EN 61000-6-2</b>	
Electrostatic discharge (ESD) EN 61000-4-2/ IEC 61000-4-2	Criterion B, 6 kV contact discharge, 8 kV air discharge
Electromagnetic fields EN 61000-4-3/IEC 61000-4-3	Criterion A, Field intensity: 10 V/m
Fast transients (burst) EN 61000-4-4/IEC 61000-4-4	Criterion A, all interfaces 1 kV Criterion B, all interfaces 2 kV
Transient overvoltage (surge) EN 61000-4-5/ IEC 61000-4-5	Criterion B, supply lines DC: 0.5 kV/0.5 kV (symmetrical/ asymmetrical), fieldbus cable shield 1 kV
Conducted interference EN 61000-4-6/IEC 61000-4-6	Criterion A; Test voltage 10 V
<b>Noise emission test as per EN 61000-6-4</b>	
EN 55011	Class A

**Approvals**

For the latest approvals, please visit [phoenixcontact.net/products](http://phoenixcontact.net/products).

**5 Internal circuit diagram**

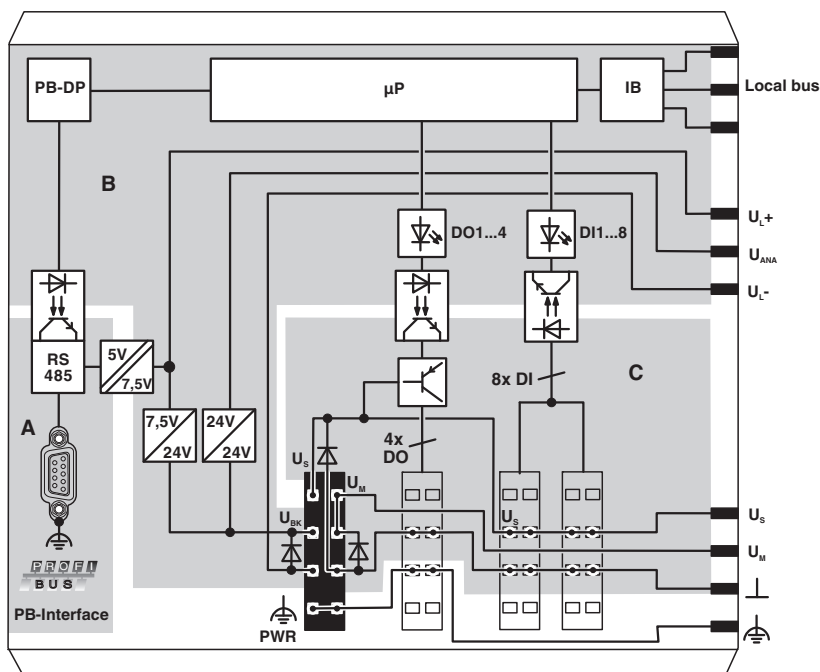











Figure 1 Internal wiring of the terminal points

Key:

	Protocol chip		RS-485 interface
	Microprocessor		PNP transistor
	Protocol chip		Electrically isolated areas
	LED	The gray areas in the basic circuit diagram represent the electrically isolated areas:	
	Optocoupler	A: PROFIBUS interface	
	Power supply unit with electrical isolation	B: Logic	
	Power supply unit	C: I/O	

## 6 Notes on using the terminal block in potentially explosive areas

**WARNING: Explosion hazard**

Please make sure that the following notes and instructions are observed.

### Approval according to ATEX Directive 2014/34/EU

Ⓜ II 3 G Ex nA IIC T4 Gc X

### Installation notes

The category 3 device is designed for installation in zone 2 potentially explosive areas.

The device meets the requirements of EN 60079–0:2012 + A11:2013 and EN 60079–15:2010.

- Observe the specified conditions for use in potentially explosive areas.
- At the time of installation, use an approved housing (minimum protection IP54), which meets the requirements of EN 60079-15. Within this context, observe the requirements of IEC 60079-14/EN 60079-14.
- The following work is only permitted in potentially explosive areas when the power is disconnected:
  - Snapping the device onto the DIN rail
  - Removing the device from the DIN rail
  - Connection and disconnection of cables
- Connect the DIN rail to the protective earth ground.
- For safe operation, the D-SUB connector must be screwed into the corresponding D-SUB socket. Repair any damaged connectors immediately.
- Only devices that are designed for operation in Ex Zone 2 and the conditions at the installation location may be connected to the circuits in Zone 2.
- When using the device in potentially explosive areas, observe the specifications in the application note AH DE IL EX ZONE 2 (German) / AH EN IL EX ZONE 2 (English).

## 7 Connection of PROFIBUS, power supply, actuators, and sensors

### 7.1 Connecting PROFIBUS

Connect PROFIBUS to the bus coupler using a 9-pos. D-SUB connector (see Ordering data). For the pin assignment, please refer to the figure and the table.

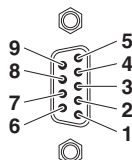

Figure 2 Pin assignment of the 9-pos. D-SUB female connector

Pin	Assignment
1	Reserved
2	Reserved
3	RxD/TxD-P (receive/transmit data +), cable B
4	CNTR-P (control signal for repeater), direction control
5	DGND (reference potential to 5 V)
6	VP (+5 V supply voltage for termination resistors)
7	Reserved
8	RxD/TxD-N (receive/transmit data -), cable A
9	Reserved

### 7.2 Mains termination resistors

Since PROFIBUS DP is a serial bus system in a line or tree structure, the individual branches must be terminated using a termination resistor. The bus coupler does not have a resistor of this type. For further information, please refer to your PROFIBUS documentation. Phoenix Contact recommends the use of the SUBCON-PLUS-PROFIB connector, Order No. 2744348. This connector has a termination resistor that can be connected.

### 7.3 Hardware configuration

The address is set using two rotary encoding switches. The left switch is used to set the position in tens and the right switch is used to set the position in units. Addresses can be set between 1 and 126. The figure shows the address setting 74.

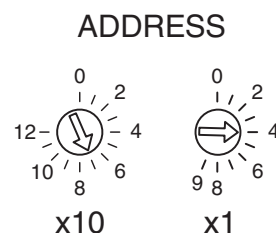

Figure 3 (ADDRESS) rotary encoding switches

7.4 Terminal point assignment of input and output connectors

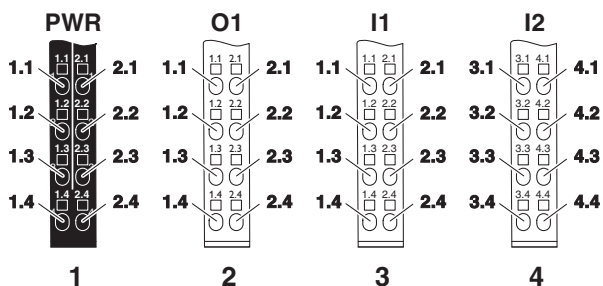

Figure 4 Terminal point assignment

Terminal point assignment of the power connector (1)

Terminal point	Assignment	Terminal point	Assignment
1.1	U <sub>S</sub>	2.1	U <sub>M</sub>
1.2	U <sub>BK</sub>	2.2	U <sub>M</sub>
1.3	GND U <sub>BK</sub>	2.3	GND U <sub>M</sub> , U <sub>S</sub>
1.4	Functional earth ground (FE)	2.4	Functional earth ground (FE)

Terminal point assignment of the output connector (2)

Terminal point	Assignment	Terminal point	Assignment
1.1	OUT01	2.1	OUT02
1.2	GND	2.2	GND
1.3	FE	2.3	FE
1.4	OUT03	2.4	OUT04

Terminal point assignment of the input connector (3)

Terminal point	Assignment	Terminal point	Assignment
1.1	IN01	2.1	IN02
1.2	U <sub>S</sub>	2.2	U <sub>S</sub>
1.3	GND	2.3	GND
1.4	IN03	2.4	IN04

Terminal point assignment of the input connector (4)

Terminal point	Assignment	Terminal point	Assignment
3.1	IN05	4.1	IN06
3.2	U <sub>S</sub>	4.2	U <sub>S</sub>
3.3	GND	4.3	GND
3.4	IN07	4.4	IN08

8 Connection example

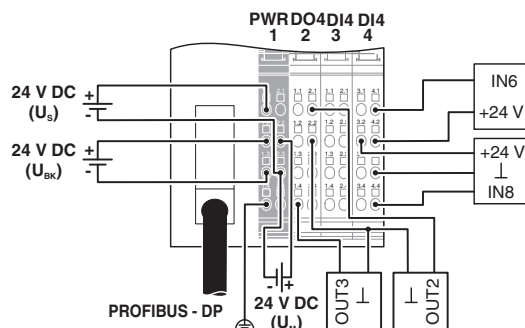

Figure 5 Connection example

## 9 Local status and diagnostic indicators

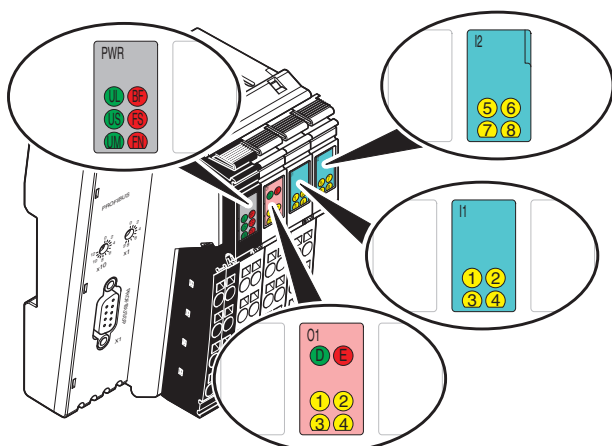

Figure 6 Local diagnostic and status indicators

Designation	Color	Meaning	State	Description
UL	Green	<b>U</b> <sub>Logic</sub>	ON	24 V bus coupler supply/7.5 V communications power present
			OFF	24 V bus coupler supply/7.5 V communications power not present
US	Green	<b>U</b> <sub>Segment</sub>	ON	24 V segment circuit supply present
			OFF	24 V segment circuit supply not present
UM	Green	<b>U</b> <sub>Main</sub>	ON	24 V I/O supply present
			OFF	24 V I/O supply not present
BF	Red	<b>Bus Fault</b>	ON	No communication on PROFIBUS
			OFF	No error
FS	Red	<b>Failure Select</b>	ON	If FS is on, FN indicates the error type
			OFF	If FS is not on, FN indicates the error number
FN	Red	<b>Failure Number</b>	Flashing	The number of flashing pulses indicates the error type or the error number, depending on whether FS is on or not
			OFF	No error
D	Green	<b>Diagnostics</b>	ON	Data transmission active within the station
			Flashing	Data transmission not active within the station
E	Red	<b>Error</b>	ON	I/O error, short-circuit/overload of outputs
			OFF	No I/O error
1 ... 4	Yellow	OUT01 ... OUT04	ON / OFF	Output is set/not set.
1 ... 8	Yellow	IN01 ... IN08	ON / OFF	Input is set/not set.

## 10 Process data

### Assignment of the terminal points to the output process data (slot 2)

Byte	0							
Bit	7	6	5	4	3	2	1	0
Slot					2			
Signal	Not used				OUT04	OUT03	OUT02	OUT01
Terminal point (signal)	Not used				2.4	1.4	2.1	1.1
Terminal point (GND)	Not used				2.2	1.2	2.2	1.2
Terminal point (FE)	Not used				2.3	1.3	2.3	1.3
LED	-				4	3	2	1

### Assignment of terminal points to the IN process data (slots 3 and 4)

Byte	0							
Bit	7	6	5	4	3	2	1	0
Slot	4				3			
Signal	IN08	IN07	IN06	IN05	IN04	IN03	IN02	IN01
Terminal point (signal)	4.4	3.4	4.1	3.1	2.4	1.4	2.1	1.1
Terminal point (24 V)	4.2	3.2	4.1	3.1	2.2	1.2	2.2	1.2
Terminal point (GND)	4.3	3.3	4.3	3.3	2.3	1.3	2.3	1.3
LED	8	7	6	5	4	3	2	1

## 11 Parameter data



During configuration, please note that connected digital I/O terminals also use parameter data in PROFIBUS. Please refer to the GSD file, application note AH EN PROFIBUS PARAMETER DATA or the terminal-specific data sheets for the parameter data length.

## 12 Firmware functions

Function	IL PB BK DI8 DO4/EF-PAC	IL PB BK DI8 DO4-PAC	IL PB BK DP/V1-PAC	
			DP/V0 mode	DP/V1 mode
<b>Process and parameter data</b>				
<b>Total amount of process data</b>				
- IN and OUT	488 bytes, maximum	488 bytes, maximum	184 bytes, maximum	176 bytes, maximum
- IN	244 bytes, maximum	244 bytes, maximum	184 bytes, maximum	176 bytes, maximum
- OUT	244 bytes, maximum	244 bytes, maximum	184 bytes, maximum	176 bytes, maximum
<b>Amount of process data for alignable I/O terminals</b>				
- IN and OUT	486 bytes, maximum	486 bytes, maximum	184 bytes, maximum	176 bytes, maximum
- IN	243 bytes, maximum	243 bytes, maximum	184 bytes, maximum	176 bytes, maximum
- OUT	243 bytes, maximum	243 bytes, maximum	184 bytes, maximum	176 bytes, maximum
<b>Amount of parameter data</b>				
- Total	244 bytes, maximum	244 bytes, maximum	8 bytes, maximum	168 bytes, maximum
- For alignable I/O terminals	230 bytes, maximum	230 bytes, maximum	0 bytes	160 bytes, maximum
<b>Amount of configuration data</b>				
- Total	244 bytes, maximum	244 bytes, maximum	168 bytes, maximum	168 bytes, maximum
- For alignable I/O terminals	239 bytes, maximum	239 bytes, maximum	168 bytes, maximum	168 bytes, maximum
<b>Other</b>				
Number of PCP devices	max. 16	max. 16	8, maximum	8, maximum
Can be replaced by IL PB BK-PAC	No	No	Yes	No
Supports DP/V1 read and write (acyclic communication), Class 1 and Class 2 master	Yes	Yes	No	Yes
Communication with PCP modules via "normal" process data (DP/V0)	Yes	Yes	Yes	Yes
Transmission invoke ID	Yes	Yes	Yes	Yes
Parameterization of several I/Os via dialog boxes in the configuration tool	Yes	Yes	No	Yes
Dynamic configuration (reserving I/Os in the PLC)	Yes	Yes	No	Yes
Specification of fail-safe values via the configuration tool	Yes	Yes	No	Yes
Byte rotation for the IB IL 24 DI 16-PAC and IB IL 24 DO 16-PAC	Yes	Yes	Yes	Yes
Byte rotation for the IB IL 24 DI 32-PAC and IB IL 24 DO 32-PAC	Yes	Yes	Yes	Yes
Operation in the event of terminal failure on the local bus	Yes	Yes	No	No
Acknowledgment of local bus stops via the application program	Yes	Yes	Yes	Yes

Function	IL PB BK DI8 DO4/EF-PAC	IL PB BK DI8 DO4-PAC	IL PB BK DP/V1-PAC	
			DP/V0 mode	DP/V1 mode
Acknowledging bus stops either automatically or via the application program	Yes	Yes	Yes	Yes
Diagnostics in IL PB BK format	Yes	Yes	Yes	Yes
Channel-specific diagnostics	Yes	Yes	No	No
Diagnostics in identification format	Yes	Yes	No	Yes
Diagnostics as status PDU	Yes	Yes	No	Yes
Stop behavior can be set via parameter telegram	Yes	Yes	Yes	Yes
I & M functions	Yes	Yes	No	No
PROFIsafe support	Yes	No	No	No
IO-Link call	Yes (FW 2.0 or later)	No	No	No
Selection of the diagnostic format in the configuration tool	Yes	No	No	No



For more detailed information about the functions described, please refer to the user manuals (see Ordering data).

### 13 IO-Link

In contrast to individual signal wiring, which was previously primarily used, IO-Link uses a 3-wire connection to sensors and actuators. This means that in addition to transmitting a simple switching signal, bidirectional serial communication is also possible. IO-Link is also suitable for mixed operation. If an interface does not support IO-Link, the device automatically switches to SIO mode (Standard Input/Output).

#### IO-Link call

IO-Link call refers to communication between the IO-Link client (PROFIBUS DP master) and the IO-Link server (IB IL IOL4 DI2-PAC Inline IO-Link master).

There can be multiple IO-Link masters in a station (depending on the amount of process data).

Read/write requests are used to access the IO-Link objects via PROFIBUS DP.



For additional information on IO-Link call communication, please refer to the UM EN IL PB BK DI8 DO4/EF-PAC user manual.

## 14 Notes on using the bus coupler in a PROFIsafe system



When using the bus coupler in a PROFIsafe system, please refer to the documentation for the safety terminals used.

It can be downloaded at [phoenixcontact.net/products](http://phoenixcontact.net/products).

The bus coupler supports Inline PROFIsafe modules. These PROFIsafe modules can also be operated together with standard I/O devices in an Inline station.

The modules map their process data to the local bus and obtain the F-Parameters and iParameters from the parameter telegram via a parameter block. The settings are provided in the GSD file.

For more detailed information, please refer to the documents listed under the ordering data. Please refer to the documentation for the components used in your application.

The maximum number of Inline terminals that can be snapped onto the bus coupler depends on the following parameters:

- Maximum number of Inline bus devices that can be snapped on: 61
- Maximum length of the process data channel: 244 bytes
- Maximum length of the parameter channel: 244 bytes

Make sure that no parameters are overwritten.



For information on the parameter data length of devices in a PROFIBUS system, please refer to application note PROFIBUS PARAMETER DATA

When operating safety terminals on the bus coupler, it is recommended that status PDU diagnostics is activated. In this operating mode, the device and parameter errors are forwarded transparently by the safety terminals to the corresponding controller.



The GSD file (electronic device data sheet) is required to configure PROFIBUS devices. This file contains all the safety modules that are currently available.

Make sure you always use the latest GSD file. It is available on the Internet at [phoenixcontact.net/products](http://phoenixcontact.net/products).

In the event that the GSD file does not yet contain the configuration data for a new safety module, this can be adjusted manually. If you have any queries regarding adjusting the GSD file, please contact the Technical Support Center.

## 15 Additional documentation



Please refer to the quick start guides and the user manual (see ordering data) for additional information on the bus coupler.



# SCATTERGOOD & JOHNSON LTD

ELECTRICAL ENGINEERING & FLUID CONTROL DISTRIBUTORS

Est.1899

At Scattergood & Johnson Ltd, we pride ourselves on being a technical distributor to specialist industries.

Working with a range of quality product suppliers across a number of specialist markets, we are not your average 'box shifter' - we are your technical and supply chain partner.

We fully support every product we sell - for free! Our internal team and external sales engineers can answer any product or application question, no matter the complexity.

Backing up this technical ability is a range of 50,000+ products available from stock for nationwide next day delivery (same day if required!), or you can collect what you need from any of our trade counters around the UK.

Select your specialist interest below to learn more about how we can help.



Online, In Branch and On the Road - Scattergood & Johnson Ltd, there when you need us.

# [www.scatts.co.uk](http://www.scatts.co.uk)