

IB IL 24 DO8/HD (2MBD)-PAC

**Inline digital output terminal, 8 outputs,
24 V DC, 500 mA**

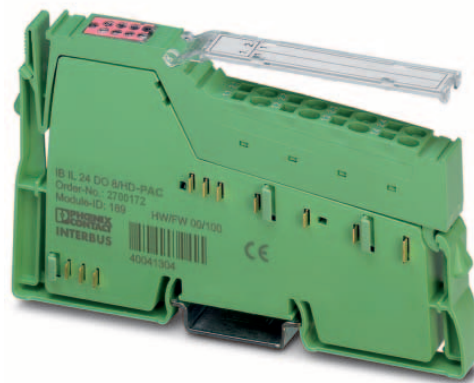

Data sheet
7985_en_03

© PHOENIX CONTACT 2011-07-22

1 Description

The terminal is designed for use within an Inline station. It is used to output digital signals.

Features

- Connections for eight digital actuators
- Connection of actuators in 1-wire technology
- Nominal current per output: 0.5 A
- Total current of the terminal: 4 A
- Short-circuit and overload protected outputs
- Diagnostic and status indicators



This data sheet is only valid in association with the IL SYS INST UM E user manual.



Make sure you always use the latest documentation.
It can be downloaded from the product at www.phoenixcontact.net/catalog.

2	Table of contents	
1	Description	1
2	Table of contents	2
3	Ordering data	3
4	Technical data	3
5	Additional tables	6
6	Internal circuit diagram	6
7	Local status and diagnostic indicators	7
8	Terminal point assignment.....	7
9	Connection notes and examples	8
10	Application examples	9
11	Process data.....	9

3 Ordering data

Description	Type	Order No.	Pcs. / Pkt.
Inline digital output terminal, complete with accessories (connector and labeling field), 8 outputs, 24 V DC, 500 mA, single-wire connection method	IB IL 24 DO8/HD-PAC	2700172	1
Inline digital output terminal, complete with accessories (connector and labeling field), 8 outputs, 24 V DC, 500 mA, transmission speed 2 MBaud, 1-wire connection method	IB IL 24 DO8/HD-2MBD-PAC	2700876	1
Accessories	Type	Order No.	Pcs. / Pkt.
Connector, for digital 1, 2 or 8-channel Inline terminals (Plug/Adapter)	IB IL SCN-8	2726337	10
Labeling field, width: 12.2 mm (Marking)	IB IL FIELD 2	2727501	10
Inline terminal for power distribution (GND), complete with accessories, (connector and labeling field) connections for GND	IB IL PD GND-PAC	2862990	1
VARIOFACE front adapter for 8-channel Inline HD modules (Plug/Adapter)	FLKM 14-PA-INLINE/DIO8	2900889	1
Documentation	Type	Order No.	Pcs. / Pkt.
User manual, English, Automation terminals of the Inline product range	IL SYS INST UM E	-	-
Data sheet, English, INTERBUS addressing	DB GB IBS SYS ADDRESS	-	-

4 Technical data

Dimensions (nominal sizes in mm)

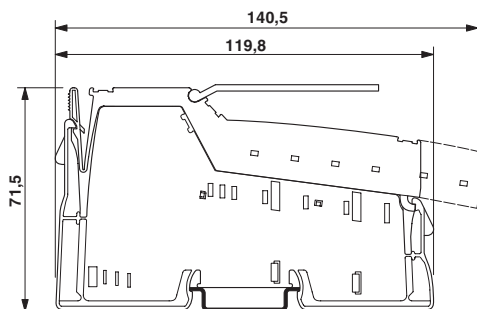

Width	12.2 mm
Height	119.8 mm
Depth	71.5 mm
Note on dimensions	Housing dimensions

General data

Color	green
Weight	60 g (With connector)
Operating mode	Process data mode with one byte
Ambient temperature (operation)	-25 °C ... 55 °C
Ambient temperature (storage/transport)	-25 °C ... 85 °C

IB IL 24 DO8/HD (2MBD)-PAC

General data

Permissible humidity (operation)	10 % ... 95 % (according to DIN EN 61131-2)
Permissible humidity (storage/transport)	10 % ... 95 % (according to DIN EN 61131-2)
Air pressure (operation)	70 kPa ... 106 kPa (up to 3000 m above sea level)
Air pressure (storage/transport)	70 kPa ... 106 kPa (up to 3000 m above sea level)
Degree of protection	IP20
Protection class	III, IEC 61140, EN 61140, VDE 0140-1

Connection data

Name	Inline connectors
Connection method	Spring-cage connection
Conductor cross section solid / stranded	0.08 mm ² ... 1.5 mm ²
Conductor cross section [AWG]	28 ... 16

Interface Inline local bus

Connection method	Inline data jumper
-------------------	--------------------

Transmission speed Inline local bus

IB IL 24 DO8/HD-PAC	500 kBit/s
IB IL 24 DO8/HD-2MBD-PAC	2 MBit/s

Power consumption

Segment supply voltage U_S	24 V DC (nominal value)
Current consumption from U_S	max. 4 A DC
Communications power U_L	7.5 V DC
Current consumption from U_L	max. 45 mA
Power consumption	max. 0.34 W (at U_L)
Power loss	max. 0.62 W

Digital outputs

Number of outputs	8
Connection method	Spring-cage connection
Connection method	1-wire
Output voltage	24 V ($U_S - 1$ V)
Maximum output current per channel	500 mA
Maximum output current per device	4 A
Nominal load, ohmic	12 W (48 Ω)
Nominal load, inductive	12 VA (1.2 H; 50 Ω)
Nominal load, lamp	12 W
Signal delay when switching on an ohmic nominal load	Typ. 500 μ s
Signal delay when switching on an inductive nominal load	Typ. 100 ms (1.2 H; 50 Ω)
Signal delay when switching on a lamp nominal load	Typ. 100 ms
Signal delay when switching off an ohmic nominal load	Typ. 1 ms
Signal delay when switching off an inductive nominal load	Typ. 50 ms (1.2 H; 50 Ω)
Signal delay when switching off a lamp nominal load	Typ. 1 ms
Maximum operating frequency with ohmic nominal load	max. 300 Hz (this switching frequency is limited by the data rate selected, the number of bus devices, the structure of the bus, the software used and the control or computer system used)
Maximum operating frequency with inductive nominal load	max. 0.5 Hz
Maximum operating frequency with lamp nominal load	max. 8 Hz (this switching frequency is limited by the data rate selected, the number of bus devices, the structure of the bus, the software used and the control or computer system used)
Reaction time with short-circuit	ca. 1 s

Digital outputs

Reaction time with ohmic overload	ca. 3 s
Behavior at voltage switch-off	The output follows the power supply without delay
One-time unsolicited energy	300 mJ
Limitation of the voltage induced on circuit interruption	$-15 \text{ V} \leq U_{\text{demag}} \leq -45.8 \text{ V}$ (U_{demag} = demagnetization voltage)
Output voltage when switched off	max. 1 V
Output current when switched off	max. 300 μA
Behavior with overload	Auto restart
Restart frequency with ohmic overload	400 Hz
Restart frequency with lamp overload	400 Hz
Behavior with inductive overload	Output can be destroyed
Reverse voltage resistance to short pulses	Reverse voltage proof
Resistance to permanent reverse voltage	max. 500 mA
Overcurrent shut-down	min. 0.7 A
Overload protection, short-circuit protection of outputs	Zener diode in output chip

Programming Data

ID code (hex)	BD
ID code (dec.)	189
Length code (hex)	81
Length code (dec.)	129
Process data channel	8 Bit
Input address area	0 Bit
Output address area	8 Bit
Parameter channel (PCP)	0 Bit
Register length (bus)	8 Bit



For the programming data/configuration data of other bus systems, please refer to the corresponding electronic device data sheet (e.g., GSD, EDS).

PROFIBUS telegram data

Required parameter data	3 Byte
Need for configuration data	4 Byte

Error messages to the higher level control or computer system

Short-circuit / overload of the digital outputs	Error message in the diagnostic code (bus) and display (2 Hz) via the LED (D) on the module
---	---

Electrical isolation/isolation of the voltage areas

5 V supply incoming remote bus/7.5 V supply (bus logic)	500 V AC , 50 Hz , 1 min
5 V supply outgoing remote bus/7.5 V supply (bus logic)	500 V AC , 50 Hz , 1 min
7.5 V supply (bus logics)/24 V supply (I/O)	500 V AC , 50 Hz , 1 min
24 V supply (I/O) / functional earth ground	500 V AC , 50 Hz , 1 min



To achieve electrical isolation between the logic level and the I/O area, supply these areas from separate power supply units. Interconnection of the power supply units in the 24 V area is not permitted (see also user manual).

Approvals

For the latest approvals, please visit www.phoenixcontact.net/catalog.

5 Additional tables

Output characteristic curve when switched on (typical)

Output current (A)	Differential output voltage (V)
0	0
0.1	0.02
0.2	0.03
0.3	0.04
0.4	0.06
0.5	0.07

6 Internal circuit diagram

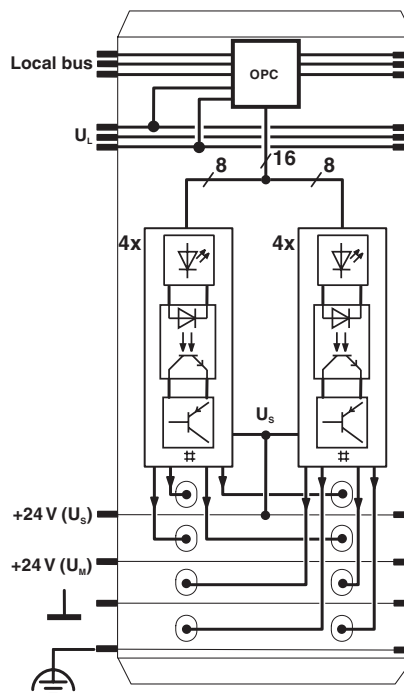







Figure 1 Internal wiring of the terminal points

-  Protocol chip (Bus logic including voltage conditioning)
-  LED (status indicator)
-  Optocoupler
-  Transistor
-  Digital output



Explanation for other used symbols has been provided in the IL SYS INST UM E user manual.

7 Local status and diagnostic indicators **8 Terminal point assignment**

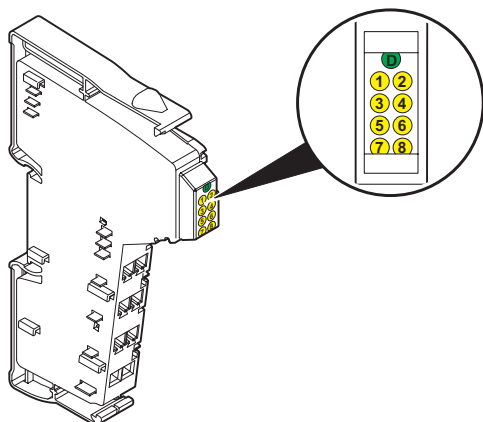

Figure 2 Local status and diagnostic indicators

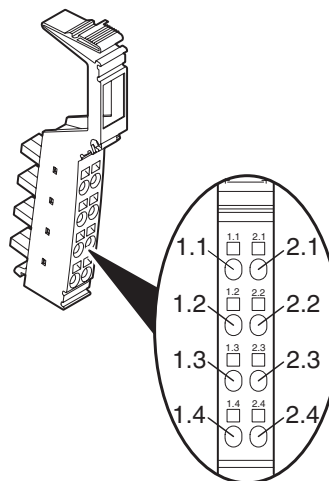

Figure 3 Terminal point assignment

Designation	Color	Meaning
D	Green	Diagnostics (bus and logic voltage)
1 to 8	Yellow	Status of the outputs

Terminal point	Assignment
1.1 / 2.1	Signal output (OUT 1 / OUT 2)
1.2 / 2.2	Signal output (OUT 3 / OUT 4)
1.3 / 2.3	Signal output (OUT 5 / OUT 6)
1.4 / 2.4	Signal output (OUT 7 / OUT 8)

Function identification

Pink

9 Connection notes and examples



When connecting the actuators, observe the assignment of the terminal points to the process data.



NOTE: Malfunction

GND of the actuators and GND of the supply voltage U_S , which supply the actuators, must have the same potential.

The simplest way to meet this requirement is to use the IB IL PD GND-PAC terminal. Wire the GND connections for the actuators to these terminals. In this way, they are connected with the potential jumper GND of the Inline station.

IB IL 24 DO8/HD-PAC IB IL PD GND-PAC

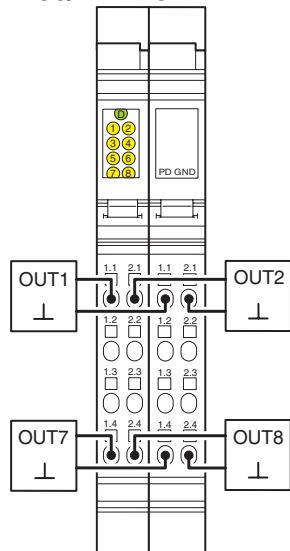

Figure 4 Typical connection of actuators when using the IB IL PD GND-PAC terminal

The actuators can also be connected via external busbars. Ensure that GND of the actuators and GND for U_S have the same potential.

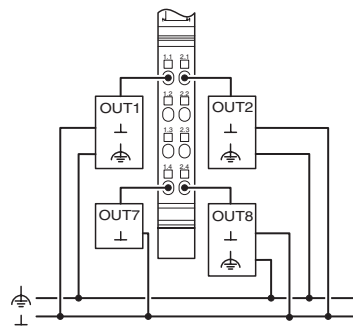

Figure 5 Typical connection of actuators when using external busbars

10 Application examples

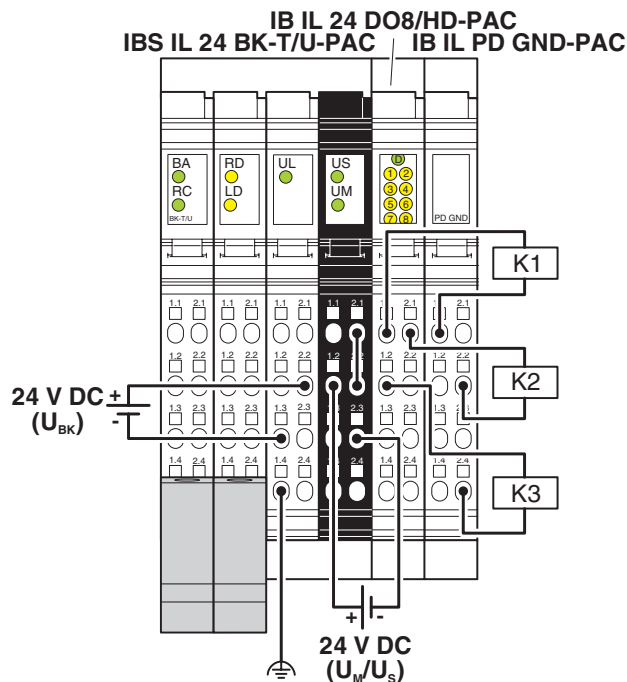

Figure 6 Connection of contactors when using the IB IL PD GND-PAC terminal

11 Process data

Assignment of the terminal points to the output process data

(Byte. Bit) view	Byte Bit	Byte 0							
		7	6	5	4	3	2	1	0
Assignment	Terminal point (signal)	2.4	1.4	2.3	1.3	2.2	1.2	2.1	1.1
Status indicator	LED	8	7	6	5	4	3	2	1



For the assignment of the illustrated (byte.bit) view to your INTERBUS control or computer system, please refer to the DB GB IBS SYS ADDRESS data sheet.

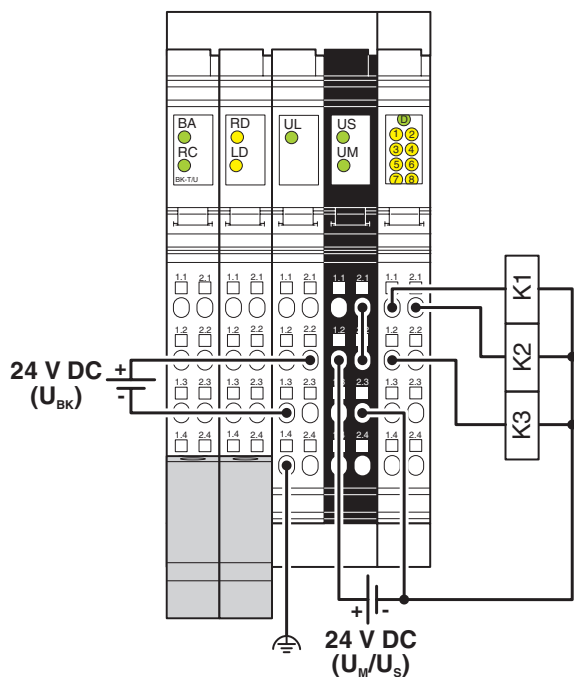

Figure 7 Connection of contactors when using external busbars



SCATTERGOOD & JOHNSON LTD

ELECTRICAL ENGINEERING & FLUID CONTROL DISTRIBUTORS

Est.1899

At Scattergood & Johnson Ltd, we pride ourselves on being a technical distributor to specialist industries.

Working with a range of quality product suppliers across a number of specialist markets, we are not your average 'box shifter' - we are your technical and supply chain partner.

We fully support every product we sell - for free! Our internal team and external sales engineers can answer any product or application question, no matter the complexity.

Backing up this technical ability is a range of 50,000+ products available from stock for nationwide next day delivery (same day if required!), or you can collect what you need from any of our trade counters around the UK.

Select your specialist interest below to learn more about how we can help.



Online, In Branch and On the Road - Scattergood & Johnson Ltd, there when you need us.

www.scatts.co.uk