



Axioline E: system and installation

User manual

UM EN AXL E SYS INT

User manual

Axioline E: system und installation

Revision 05

2019-10-16

This user manual is valid for Axioline E devices.

8395_en_05

Table of contents

1.1	Labeling of warning notes	5
1.2	Qualification of users	5
1.3	Product changes	6
1.4	Security in the network	6
2	Axioline E product group	7
2.1	Axioline E networks	7
2.2	Axioline E product variants	8
2.3	Axioline E product portfolio	9
2.4	Axioline E product designation	11
2.5	Axioline E documentation	12
2.6	Axioline E Device description file	15
2.7	For your safety	16
2.7.1	Intended use	16
2.7.2	Regulations	16
2.7.3	Safety notes	16
3	Description of the Axioline E devices	17
3.1	Housing dimensions of Axioline E plastic devices	17
3.1.1	Ethernet versions (PROFINET, EtherNet/IP™, Sercos, Ethernet (Modbus/TCP), EtherCAT®)	17
3.1.2	PROFIBUS versions	18
3.2	Housing dimensions of Axioline E metal devices	19
3.2.1	Ethernet versions (PROFINET, EtherNet/IP™, Sercos, Ethernet (Modbus/TCP), EtherCAT®)	19
3.2.2	PROFIBUS versions	20
3.3	Dimensions of screw holes in the fixing clips	21
3.4	Basic structure of the Axioline E devices	22
3.5	Marking the Axioline E devices	23
3.6	Diagnostics and status indicators of the Axioline E devices	24
4	Mounting Axioline E devices and connecting cables	25
4.1	General information on installation	25
4.1.1	Installing network/bus cables between buildings	27
4.1.2	Interference suppression measures	28
4.1.3	Grounding concept	28
4.2	Installation instructions	29
4.3	Mounting distances	29
4.4	Mounting Axioline E plastic devices	30
4.5	Mounting Axioline E metal devices	31
4.5.1	Mounting metal devices using extendable fixing clips	31
4.5.2	Attaching the metal device using a mounting plate	32

UM EN AXL E SYS INST

4.6	Configuration via rotary coding switches	34
4.7	Cable connection.....	35
4.8	Connecting power supplies	36
4.8.1	Power supplies U_S and U_A	36
4.8.2	Power supply for sensors and actuators of individual devices	38
4.8.3	Examples for voltage supply	39
4.8.4	Supply line and power supply (M12)	39
4.8.5	Calculation example for sensor and actuator currents	40
4.9	Connecting sensors and actuators	41
5	Axioline E IO-Link devices	43
5.1	Axioline E IO-Link master	45
5.2	Axioline E IO-Link digital input and output devices	46
5.2.1	Housing dimensions of the Axioline E IO-Link digital input and output devices	46
5.2.2	Basic structure of the Axioline E IO-Link digital input and output devices	47
5.2.3	Marking of the Axioline E IO-Link digital input and output devices	48
5.2.4	Diagnostic and status indicators of the Axioline E IO-Link digital input and output devices	48
5.2.5	Mounting of the Axioline E IO-Link digital input and output devices	49
5.3	IO-Link/analog converter	50
5.3.1	Dimensions of the straight IO-Link/analog converter	52
5.3.2	Dimensions of the rectangular IO-Link/analog converter	52
5.3.3	Connections of the straight IO-Link/analog converter	53
5.3.4	Connections of the rectangular IO-Link/analog converter	53
5.3.5	Mounting of the IO-Link/analog converter	54
5.4	IO-Link/analog converter (AXL E IOL TC4/K M12 device)	55
5.4.1	Dimensions of the AXL E IOL TC4/K M12 device	55
5.4.2	Connection and display of the AXL E IOL TC4/K M12 device	56
5.4.3	Mounting of the AXL E IOL TC4/K M12 device	56
5.5	Axioline E IO-Link topology.....	57

1 For your safety

Read this user manual carefully and keep it for future reference.

1.1 Labeling of warning notes



This symbol indicates hazards that could lead to personal injury. There are three signal words indicating the severity of a potential injury.

DANGER

Indicates a hazard with a high risk level. If this hazardous situation is not avoided, it will result in death or serious injury.

WARNING

Indicates a hazard with a medium risk level. If this hazardous situation is not avoided, it could result in death or serious injury.

CAUTION

Indicates a hazard with a low risk level. If this hazardous situation is not avoided, it could result in minor or moderate injury.



This symbol together with the **NOTE** signal word alerts the reader to a situation which may cause damage or malfunction to the device, hardware/software, or surrounding property.



Here you will find additional information or detailed sources of information.

1.2 Qualification of users

The use of products described in this user manual is oriented exclusively to:

- Qualified electricians or persons instructed by them. The users must be familiar with the relevant safety concepts of automation technology as well as applicable standards and other regulations.
- Qualified application programmers and software engineers. The users must be familiar with the relevant safety concepts of automation technology as well as applicable standards and other regulations.

1.3 Product changes

Changes or modifications to hardware and software of the device are not permitted.

Incorrect operation or modifications to the device can endanger your safety or damage the device. Do not repair the device yourself. If the device is defective, please contact Phoenix Contact.

1.4 Security in the network

**NOTE: : Risk of unauthorized network access**

Connecting devices to a network via Ethernet always entails the risk of unauthorized access to the network.

Therefore, please check your application for any option of deactivating active communication channels. Setting passwords to prevent third parties from accessing the controller without authorization and modifying the system.

Because of the controller's communication interfaces, we advise against using the controller in safety-critical applications without additional security appliances.

Please take additional protective measures according to the IT security requirements and the standards applicable to your application (for instance virtual networks (VPN) for remote maintenance access, firewalls, etc.) for protection against unauthorized network access.

On first request, you shall release Phoenix Contact and the companies associated with Phoenix Contact GmbH & Co. KG, Flachmarktstraße 8, 32825 Blomberg in accordance with §§ 15 ff. AktG or German Stock Corporation Act (hereinafter collectively referred to as "Phoenix Contact") from all third-party claims that are made due to improper use.

For the protection of networks for remote maintenance via VPN, Phoenix Contact offers the mGuard product series security appliances which you can find described in the latest Phoenix Contact catalog (phoenixcontact.net/products).

Additional measures for protection from unauthorized network access can be found in the AH EN INDUSTRIAL SECURITY application note. The application note can be downloaded at phoenixcontact.net/products.

2 Axioline E product group

The input and output devices in the Axioline E product group are designed for distributed automation tasks in harsh environmental conditions. The devices meet the requirements for IP65/IP67 protection. They find their use in the field with high decentralization. They enable the direct connection of sensors and actuators in the field.

The connection of the network, I/Os and the supply is carried out via screwable M12 connectors.

2.1 Axioline E networks

The Axioline E devices are available for the following networks:

PROFINET



EtherNet/IP™



Sercos®



Ethernet (Modbus/TCP)



EtherCAT®



PROFIBUS



2.2 Axioline E product variants

The Axioline E product group includes devices with the following functions:

- **DI** Digital input devices acquire digital control signals from the process level. These signals are transferred to the higher-level automation device via the network. The signal status is indicated on the Axioline E device using LEDs. The sensors are connected via M12 screw connectors. The sensors are supplied from the sensor voltage U_S .
- **DO** Digital output devices transfer the digital control signals from the automation device to the process level at the actuators. For the specified load currents for the outputs of various devices, please refer to the data sheet. The signal status is indicated on the device using LEDs. The actuators are connected via M12 screw connectors. The outputs are short-circuit-proof and protected against overload. The actuators are supplied from the actuator voltage U_A (Exception DIO).
- **DIO** Digital I/O devices have digital inputs and digital outputs with the same properties as the input and output devices. The inputs and outputs are freely configurable. For the DIO devices, the actuator supply is via U_S .
- **DI DO** Digital I/O devices have digital inputs and digital outputs with the same properties as the input and output devices.
- **IOL** These devices have IO-Link ports for communication-capable sensors and actuators. IO-Link is a communication system for the connection of intelligent sensors and actuators to an automation system.

IO-Link master

The Axioline E product portfolio contains an IO-Link master for each of the networks listed in chapter 2.1. The IO-Link master is versatile and is available as a plastic or metal variant.

The IO-Link master enables the operation of up to eight IO-Link sensors/actuators and is also used to acquire digital signals. Together with the IO-Link/analog converters, the devices allow flexible processing of the signal volume in the field installation.



You will find further information on IO-Link masters in the Chapter 3 „Description of the Axioline E devices“ and in the corresponding data sheets.

Digital input and output devices via IO-Link

The Axioline E product group is supplemented with IO-Link digital input and output devices. These IO-Link devices solve the customer's request to capture or output various I/O signals at a central point via IO-Link.

The Axioline E digital input device is connected to an IO-Link master via an IO-Link A port. It is used to acquire digital signals via IO-Link.

The Axioline E digital output device is connected to an IO-Link master via an IO-Link B port. It is used to output digital signals via IO-Link. Via the IO-Link master the use within different networks is possible.

IO-Link/analog converter

The IO-Link/analog converter is an IO-Link device that converts analog signals into the IO-Link protocol. Depending on the version, it allows you to acquire the signals from analog sensors via an IO-Link master or to transmit them to analog actuators.

The Axioline E IO-Link/analog converter is an IO-Link device that transmits analog signals from thermocouples (TC) via the IO-Link-protocol. The device therefore offers the option of acquiring the signals of analog sensors of standard thermocouples (TC) type K via an IO-Link master. It supports type K thermocouples according to DIN EN 60584-1.

2.3 Axioline E product portfolio

The following tables give an overview of the Axioline E product portfolio.

Axioline E devices (Digital I/O devices and IO-Link master)

Axioline E plastic devices		Axioline E metal devices	
Article designation	Order No.	Article designation	Order No.
PROFINET		PROFINET	
AXL E PN DI16 M12 6P	2701510	AXL E PN DI16 M12 6M	2701516
AXL E PN DIO16 M12 6P	2701511	AXL E PN DIO16 M12 6M	2701517
AXL E PN DI8 DO8 M12 6P	2701509	AXL E PN DI8 DO8 M12 6M	2701515
AXL E PN DI8 DO4 2A M12 6P	2701512	AXL E PN DI8 DO4 2A M12 6M	2701518
AXL E PN IOL8 DI4 M12 6P	2701513	AXL E PN IOL8 DI4 M12 6M	2701519
EtherNet/IP™		EtherNet/IP™	
AXL E EIP DI16 M12 6P	2701493	AXL E EIP DI16 M12 6M	2701488
AXL E EIP DIO16 M12 6P	2701494	AXL E EIP DIO16 M12 6M	2701489
AXL E EIP DI8 DO8 M12 6P	2701492	AXL E EIP DI8 DO8 M12 6M	2701487
AXL E EIP DI8 DO4 2A M12 6P	2701495	AXL E EIP DI8 DO4 2A M12 6M	2701490
AXL E EIP IOL8 DI4 M12 6P	2701496	AXL E EIP IOL8 DI4 M12 6M	2701491
Sercos®		Sercos®	
AXL E S3 DI16 M12 6P	2701544	AXL E S3 DI16 M12 6M	2701549
AXL E S3 DIO16 M12 6P	2701545	AXL E S3 DIO16 M12 6M	2701550
AXL E S3 DI8 DO8 M12 6P	2701542	AXL E S3 DI8 DO8 M12 6M	2701548
AXL E S3 DI8 DO4 2A M12 6P	2701546	AXL E S3 DI8 DO4 2A M12 6M	2701551
AXL E S3 IOL8 DI4 M12 6P	2701547	AXL E S3 IOL8 DI4 M12 6M	2701552
Ethernet		Ethernet	
AXL E ETH DI16 M12 6P	2701533	AXL E ETH DI16 M12 6M	2701538
AXL E ETH DIO16 M12 6P	2701534	AXL E ETH DIO16 M12 6M	2701539
AXL E ETH DI8 DO8 M12 6P	2701532	AXL E ETH DI8 DO8 M12 6M	2701537
AXL E ETH DI8 DO4 2A M12 6P	2701535	AXL E ETH DI8 DO4 2A M12 6M	2701540
AXL E ETH IOL8 DI4 M12 6P	2701536	AXL E ETH IOL8 DI4 M12 6M	2701541
EtherCAT®		EtherCAT®	
AXL E EC DI16 M12 6P	2701521	AXL E EC DI16 M12 6M	2701526
AXL E EC DIO16 M12 6P	2701522	AXL E EC DIO16 M12 6M	2701528
AXL E EC DI8 DO8 M12 6P	2701520	AXL E EC DI8 DO8 M12 6M	2701525
AXL E EC DI8 DO4 2A M12 6P	2701523	AXL E EC DI8 DO4 2A M12 6M	2701529
AXL E EC IOL8 DI4 M12 6P	2701524	AXL E EC IOL8 DI4 M12 6M	2701531
PROFIBUS		PROFIBUS	
AXL E PB DI16 M12 6P	2701498	AXL E PB DI16 M12 6M	2701505
AXL E PB DIO16 M12 6P	2701499	AXL E PB DIO16 M12 6M	2701506
AXL E PB DI8 DO8 M12 6P	2701497	AXL E PB DI8 DO8 M12 6M	2701504
AXL E PB DI8 DO4 2A M12 6P	2701502	AXL E PB DI8 DO4 2A M12 6M	2701507
AXL E PB IOL8 DI4 M12 6P	2701503	AXL E PB IOL8 DI4 M12 6M	2701508

UM EN AXL E SYS INST

Axioline E
digital input and output
device via IO-Link**Axioline E digital input and output devices via IO-Link (plastic)**

Article designation	Order No.
AXL E IOL DI8 M12 6P	2702658
AXL E IOL DI16 M12 6P	2702660
AXL E IOL DO8 M12 6P	2702659

Axioline E
IO-Link/analog converter**Axioline E IO-Link/analog converter (plastic)**

Article designation	Order No.	Design
AXL E IOL AI1 U M12 R	2700273	Rectangular version
AXL E IOL AI1 I M12 R	2700275	
AXL E IOL AO1 U M12 R	2700278	
AXL E IOL AO1 I M12 R	2700282	
AXL E IOL RTD1 M12 R	2700305	
AXL E IOL AI1 U M12 S	2700336	Straight version
AXL E IOL AI1 I M12 S	2700338	
AXL E IOL AO1 U M12 S	2700350	
AXL E IOL AO1 I M12 S	2700351	
AXL E IOL RTD1 M12 S	2700352	
AXL E IOL TC4/K M12	2702983	Box

2.4 Axioline E product designation

The following tables give you an overview of the meaning of product names within the Axioline E product group.

Structure of the product designation

Product range	Product group	Network	I/O type	Extention	Network connection I/O connection	Width in cm/ housing material
AXL	E	PN	Dlx	2A	M12	6M
		EIP	Dlx DOx			
		S3	DIOx			
		ETH	IOLx Dlx			
		EC	IOL Dlx			
		PB	IOL DOx			

Example:

AXL	E	PB	DI8 DO4	2A	M12	6P
AXL	E	-	IOL DO8	-	M12	6P

Meaning of the product designation

Abbreviation	Meaning
AXL	Axioline
E	Name of the product group
PN	PROFINET
EIP	EtherNet/IP™
S3	Sercos
ETH	Ethernet (Modbus/TCP)
EC	EtherCAT®
PB	PROFIBUS
IOL	IO-Link
Dlx	x digital inputs
DOx	x digital outputs
Dlx DOx	x digitale inputs; x digital outputs
DIOx	x freely configurable inputs or outputs
TC4/K	Number of thermocouples, type K
2A	Nominal current of an output is 2 A
M12	M12 connector
6M	6 cm wide, metal housing
6P	6 cm wide, plastic housing

2.5 Axioline E documentation

The documentation for the Axioline E product group is modular in order to meet your specific requirements, e.g., for installation or commissioning with a software to provide the best information.

User manual

This user manual is the higher - level system manual for the Axioline E product group.

It includes:

- Description of the Axioline E system
- Functions and properties of the devices
- Mounting
- Concept of power supply

Network specific IO-Link user manuals

For the IO-Link devices, there is a user manual for each network. This describes the network/bus-specific properties of an Axioline E-IO-Link device.

The following user manuals are available:

- Network-specific properties of the Axioline E-PROFINET IO-Link devices
- Network-specific properties of the Axioline E EtherNet/IP™ IO-Link devices
- Network-specific properties of the Axioline E Sercos IO-Link devices
- Network-specific properties of the Axioline E-Ethernet-IO-Link devices
- Network-specific properties of the Axioline E-EtherCAT®-IO-Link devices
- Bus-specific properties of the Axioline E-PROFIBUS-IO-Link devices

Packing slip

A package slip is included with the unit upon delivery. It contains the most important information about the electrical installation of a device or a group of devices.

This includes:

- Short description of the device
- Safety notes
- Drawing, dimensions in mm
- Mounting/demounting
- Connections
- Pin assignment

Device-specific data sheets

There is a data sheet for every device. The data sheet describes the specific properties of an Axioline E device.

This includes:

- Device description
- Ordering data and technical data
- Basic circuit diagram
- Connection assignment
- Connection example
- Local diagnostics and status indicators
- Processdata*
- Startup*
- Specific network/bus features*

* Refer to the IO link masters in the network/bus-specific user manuals.

Application notes and quickstarts

For complete information, please use the application notes and quickstarts.

An application notes provides additional information on specific topics.

A quickstarts describes the commissioning of a device step by step on an example.

The following application notes and quickstarts are available for the Axioline E system:

- Wiring of AXL E devices

PROFINET

- Startup of Axioline E PROFINET devices on a SIMATIC® S7 controller
- Startup of Axioline E PROFINET IO-Link devices on a SIMATIC® S7 controller
- Startup of Axioline E PROFINET IO-Link devices on a SIMATIC® S7 controller in the TIA portal
- Startup of Axioline E PROFINET devices using PC WORX
- Startup of Axioline E PROFINET IO-Link devices using PC WORX
- Updating the firmware of AXL E devices using the Windows Explorer
- Changing the partner ports with AXL E PROFINET devices under STEP 7
- Changing the partner ports with AXL E PROFINET devices under STEP 7 in the TIA Portal

EtherNet/IP™

- Startup of Axioline E EtherNet/IP™ IO-Link devices with RSLOGIX
- Updating the firmware of AXL E devices using the Windows Explorer

Sercos

- Startup of Axioline E Sercos devices with INDRAWORKS
- Updating the firmware of AXL E devices using the Windows Explorer

Ethernet

- Startup of Axioline E-Ethernet devices with MODSCAN32
- Updating the firmware of AXL E devices using the Windows Explorer

UM EN AXL E SYS INST

EtherCAT®

- Startup of Axioline E-EtherCAT® devices with TwinCAT®
- Startup of Axioline E-EtherCAT® IO-Link devices with CODESYS
- Startup of the Axioline F buscoupler for EtherCAT® and for Axioline E devices for EtherCAT® at Sysmac Studio

PROFIBUS

- Startup of Axioline E PROFIBUS devices on a SIMATIC® S7

Phoenix Contact catalogs

The Phoenix Contact catalogs contain the ordering data for all Axioline E products.

This includes:

- Bus cables
- Shielded bus connectors
- Unshielded connectors
- Mounting systems
- Termination resistors
- Other accessories

Documentation on the internet

This documentation can be downloaded at phoenixcontact.net/products. Here you will find information on each product. During your search, take into account the difference between “Generate product PDF” and “Download”.

Generate product PDF





Click the “Generate product PDF” button to receive up-to-date selected information. It provides a short overview of the device. The generated PDF file contains the essential product information. If you require further information, you can use the “Downloads” tab.

Downloads

Under the “Downloads” tab, you can access the complete documentation and all other downloads related to a device.

2.6 Axioline E Device description file

An Axioline E device is intrated into a control system via a standardized device description file. This is evaluated at runtime, thus enabling the Axioline E device to be operated with the specific settings. Axioline E devices in the ETH (Modbus / TCP) network are excluded. These do not require a device description file.

Device description file	Network	
GSDML Generic Station Description Markup Language		Axioline E.PROFINET devices are intrated language independent XML-based files (GSDML).
EDS Electronic Data Sheet		Axioline E-EtherNet/IP™ devices are intrated using Electronic Data Sheets (EDS).
SDDML Sercos Device Description Markup Language		For Axioline E Sercos devices the intration is via XML-based device description files (SDDML).
ESI EtherCAT® Slave Information		Axioline E-EtherCAT® devices are intrated via EtherCAT® Slave Information (ESI).
GSD General Station Description		Axioline E PROFIBUS devices are intrated using device description files (GSD).



You will find current device description files at the address phoenixcontact.net/products.

2.7 For your safety

2.7.1 Intended use

The Axioline E devices are designed for use as specified in this user manual and in the device-specific data sheets.

Observe the data specified in the data sheets and in the user manual. If the operating instructions and safety notes for configuration, installation, and operation given in the documentation are followed, the devices should not normally present a danger to people or property.

2.7.2 Regulations

During device configuration, installation, startup, and maintenance, the applicable safety and accident prevention regulations for the specific application must be observed.

2.7.3 Safety notes

**NOTE: Device damage**

To ensure IP65/IP67 protection, seal unused connections with protective caps.

**NOTE: Data corruption or loss**

Ground the devices to provide immunity to interference.

**NOTE: Device damage**

Only operate the Axioline E devices with a maximum SELV of 30 V according to IEC 60950/EN 60950/VDE 0805.

3 Description of the Axioline E devices

Axioline E devices are designed for use without a control cabinet in systems manufacturing. Irrespective of the network/bus system, the devices are available in plastic or metal. The Axioline E IO-Link digital input and output devices and the IO-Link/analog converter are only available in plastic variants.

The metal devices are particularly suitable for use under harsh industrial conditions. They can be used on tool platforms, directly on welding robots or in conveying technology, for example.

The housing dimensions of the plastic and metal devices are identical. They only differ with regard to the fixing clips. These are fixed for the plastic devices, but are extendable in the case of the metal devices. Furthermore, a mounting plate can be used to fix the metal devices.

The housing dimensions of the PROFIBUS devices differ from the housing dimensions of the Ethernet versions with regard to the depth at socket X21.

3.1 Housing dimensions of Axioline E plastic devices

3.1.1 Ethernet versions (PROFINET, EtherNet/IP™, Sercos, Ethernet (Modbus/TCP), EtherCAT®)

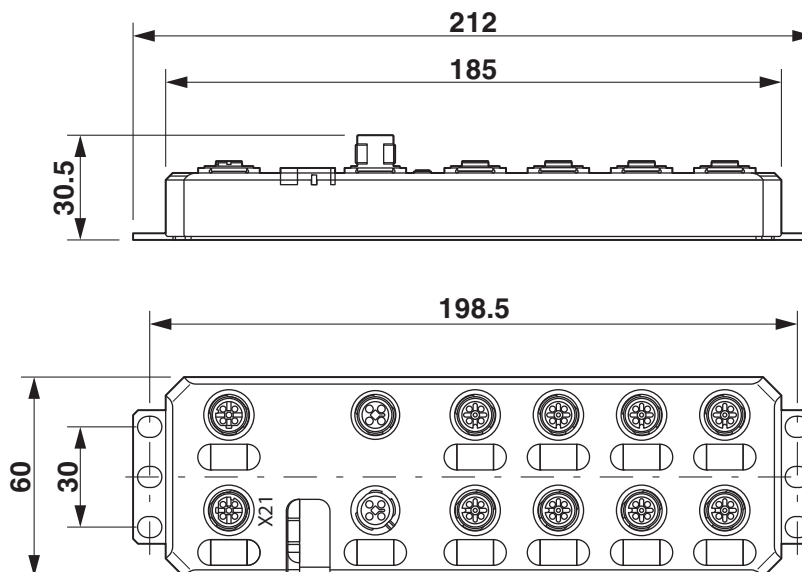

Figure 3-1 Housing dimensions (mm) plastic devices, Ethernet versions

The height is 212 mm including fixing clips.

3.1.2 PROFIBUS versions

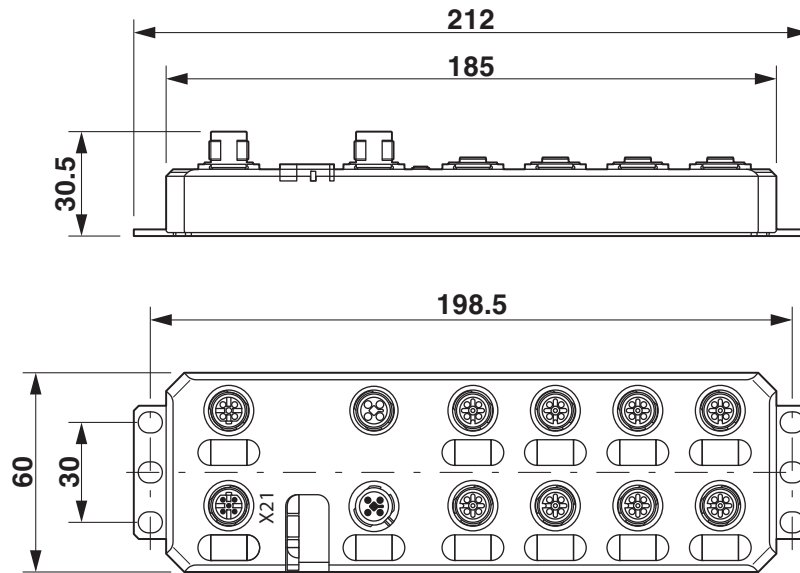

Figure 3-2 Housing dimensions (mm) of PROFIBUS plastic devices

The height is 212 mm including fixing clips.

3.2 Housing dimensions of Axioline E metal devices

3.2.1 Ethernet versions (PROFINET, EtherNet/IP™, Sercos, Ethernet (Modbus/TCP), EtherCAT®)

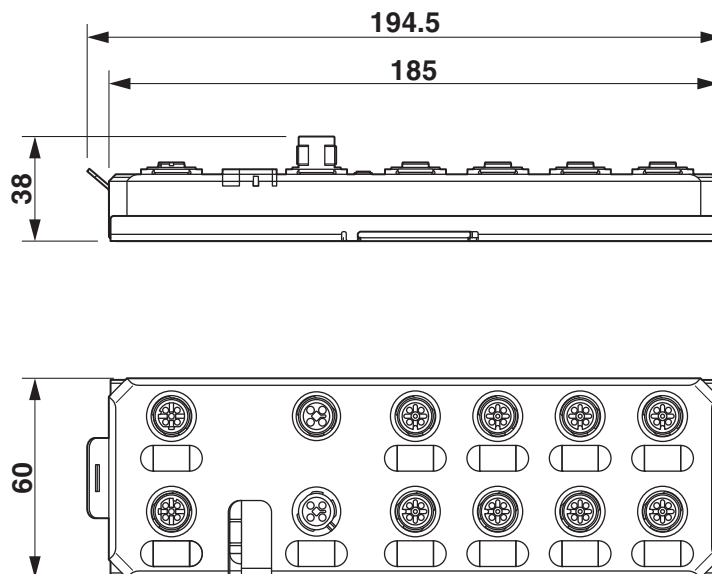

Figure 3-3 Housing dimensions (mm) of metal devices with mounting plate

The height is 194.5 mm including the mounting plate. The depth is 38 mm including the mounting plate.

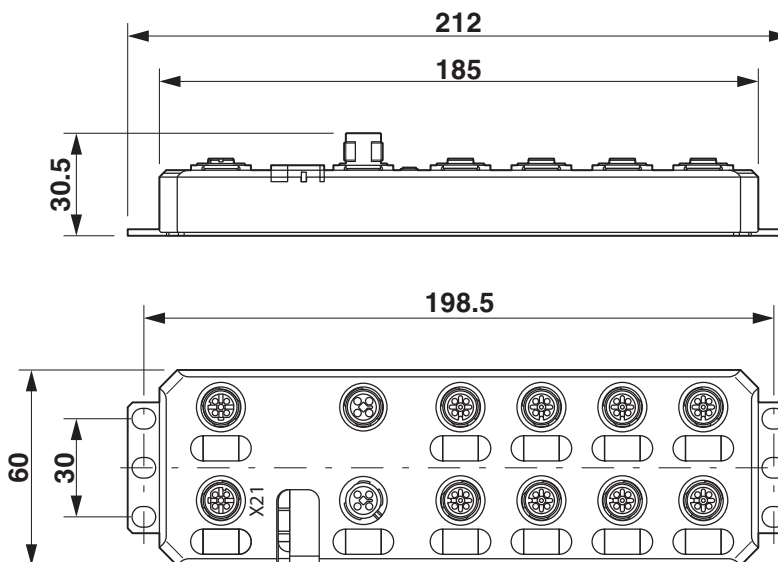

Figure 3-4 Housing dimensions (mm) of metal devices with extended fixing clips

3.2.2 PROFIBUS versions

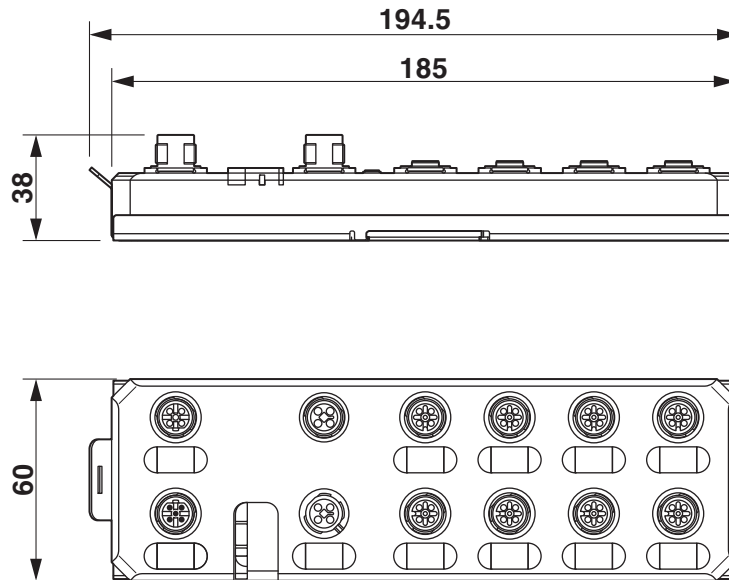

Figure 3-5 Housing dimensions (mm) of PROFIBUS metal devices with mounting plate

The height is 194.5 mm including the mounting plate. The depth is 38 mm including the mounting plate.

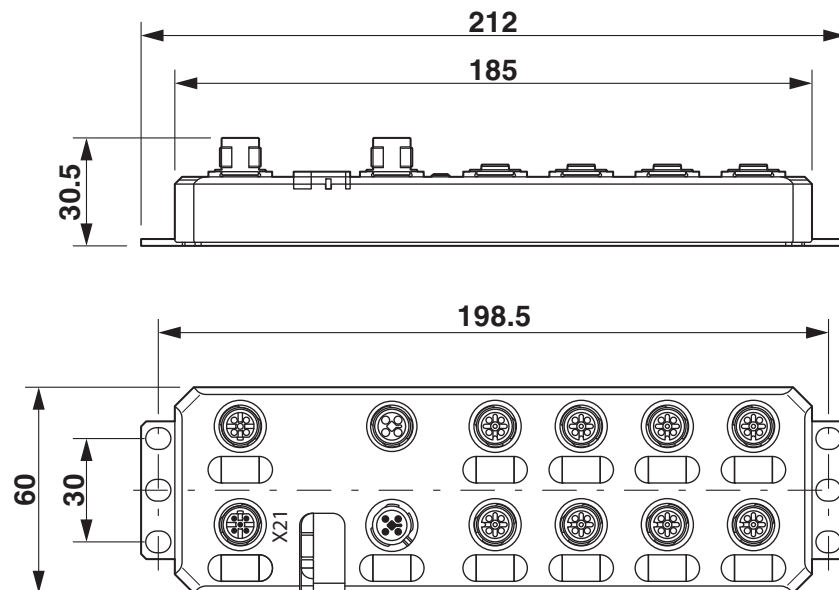

Figure 3-6 Housing dimensions (mm) of PROFIBUS metal devices with extended fixing clips

3.3 Dimensions of screw holes in the fixing clips

The drawing below shows the dimensions of the screw holes in the fixing clips.

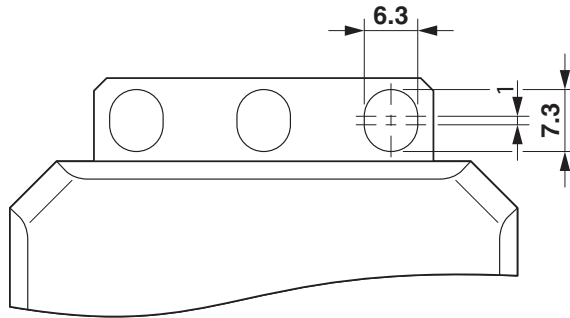

Figure 3-7 Dimensions of the screw holes in mm

3.4 Basic structure of the Axioline E devices

The figure shows the basic structure of the Axioline E devices.

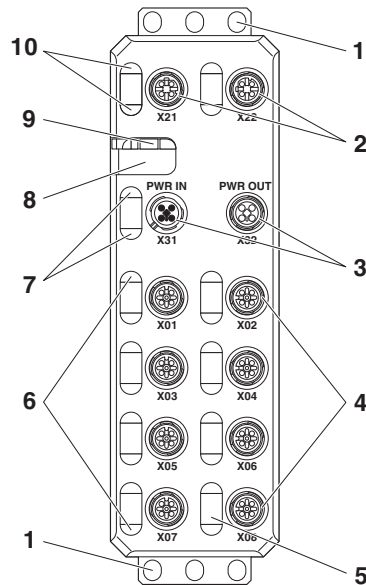

Figure 3-8 Basic structure of the Axioline E devices

- | | |
|---|---|
| <p>1 Fixing clips (FE connection); optional for metal devices</p> <p>2 Network or bus connection (IN, OUT)</p> <p>3 Connections for the supply voltages</p> <p>4 Connections of the input/outputs or IO-Link ports</p> <p>5 Markers for marking</p> <p>6 Status indicators of the inputs/outputs or the IO-Link ports</p> | <p>7 Diagnostics and status indicators for the supply voltages</p> <p>8 Rotary coding switch</p> <p>9 Diagnostics and status indicators for the network/bus system</p> <p>10 Diagnostics and status indicators for the network (not for PROFIBUS)</p> |
|---|---|

3.5 Marking the Axioline E devices

It is possible to mark the devices next to the connections for the network, to mark the connections for the power supply, and to mark every I/O connection/IO-Link port (5 in Figure 3-8).

The devices are supplied as standard with ten unprinted marking labels.

If you want to swap a label, you can lift it out of the recess using a screwdriver.



Phoenix Contact offers the CMS-MARK-WIN software for professional marking, see Phoenix Contact catalog.

3.6 Diagnostics and status indicators of the Axioline E devices

Diagnostics

The diagnostics indicators (green/yellow/red) indicate whether an error is present or not. In the event of an error, they indicate the error type and location.

Status

The status indicators (yellow) indicate the signal state of the corresponding input/output or of the IO-Link port. If the yellow status indicators are on, this indicates signal state "1" of the input/output signal.

The Axioline E devices have three main areas for diagnostics and status indicators.

- Indicators for the network/bus system (network/bus-specific) - **data**
- Indicators for the power supplies - **power**
- Indicators for the inputs and outputs and the IO-Link ports (device-specific) - **signal**

These areas are shown in Figure 3-9.

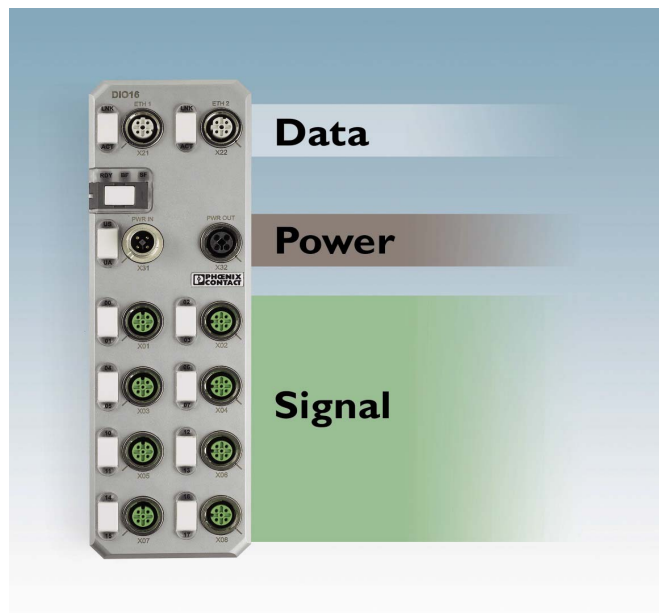

Figure 3-9 Main diagnostics and status indicators of the Axioline E devices



For more detailed information on the diagnostics and status indicators, please refer to the data sheet for the respective device.

4 Mounting Axioline E devices and connecting cables

4.1 General information on installation

When preparing for cable installation, the local conditions and the corresponding mounting regulations are very important. Cables can be installed, for example, in cable ducts or on cable bridges.



NOTE: Data corruption and loss

A minimum distance between the cabling and possible sources of interference (e.g., machines, welding equipment, power lines) is defined in the applicable regulations and standards. During system planning and installation, these regulations and standards must be taken into account and observed.



NOTE: Data corruption and loss

Protect the bus cables from sources of electric/magnetic interference and mechanical strain.



NOTE: Data corruption and loss

Observe the following guidelines regarding “electromagnetic compatibility” (EMC) to keep mechanical risks and interference to a minimum:

Mechanical strain

- Choose the correct cable type for the respective application (e.g., indoor or outdoor installation, drag chains).
- Observe the minimum bending radius.
- Make sure that cables do not enter the shear area of moving machine parts.
- Do not install bus cables at right angles to driving routes and machine movements.
- Use cable ducts and cable bridges.



Observe the specifications of the cables used.

UM EN AXL E SYS INST

Sources of interference

- Signal cables and power supply lines should not be installed in parallel. If necessary, metal isolating segments should be placed between the power supply lines and signal cables.
- Only use connectors with metal housing and connect as much of the shielding as possible to the housing.
- For outdoor cables between buildings, make sure that grounding is carried out in accordance with on page 27.
- During installation, all connector locking mechanisms (screws, union nuts) must be firmly tightened in order to ensure the best possible contact between shielding and ground. Before initial startup, the ground or shielding connection of cables must be checked for low-resistance continuity.
- Install network/bus cables in separate cable ducts or separate cable bundles.
- Where possible, do not install network/bus cables parallel to power supply lines.
- Install network/bus cables at least 10 cm away from power lines.

Cable routing in buildings

- Where possible, use metal cable hangers.
- Do not install network/bus cables together with or parallel to power supply lines.
- Separate network/bus cables on cable bridges or in cable ducts from power supply lines using isolating segments.
- Install network/bus cables as far away as possible from sources of interference, such as motors and welding equipment.
- For long cable connections, install an additional equipotential bonding line between the terminal points.

Cable routing outside buildings

- Install network/bus cables in metal pipes that are grounded on both sides or in concrete cable ducts with continuous reinforcement.
- For long cable connections, install an additional equipotential bonding line between the terminal points.

4.1.1 Installing network/bus cables between buildings

Causes of surge voltages

Surge voltages occur as a result of switching operations, electrostatic discharge, and lightning discharge. Surge voltages can be inductively, capacitively or galvanically coupled into electrical cables for mains supply, measured value transmission, and data transmission. In this way, surge voltages reach the power supply units and the interfaces of systems and termination devices.

Equipotential bonding line

Install an additional equipotential bonding line between the grounding points of buildings (3 in Figure 4-1), which is preferably in the form of:

- A metal-reinforced concrete channel
- An additional grounding cable
- A metal pipe

Surge protective devices

Phoenix Contact recommends wiring all the wires of the cable to surge protective devices (1 in Figure 4-1) in order to protect the devices against surge voltages.



For information on surge protective devices, please refer to the Phoenix Contact catalogs. Observe all national and international regulations when installing surge protective devices.

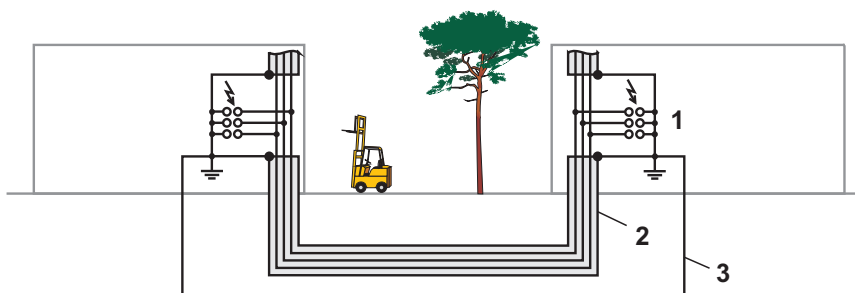

6651A041

Figure 4-1 Surge protection measures

- 1 Surge protective devices
- 2 Cable shielding
- 3 Equipotential bonding line

4.1.2 Interference suppression measures

Phoenix Contact recommends wiring relay coils or motor coils to an RC element in order to protect the devices against interference. Depending on the application, the delay time of the relay can be increased by approximately 1 ms.

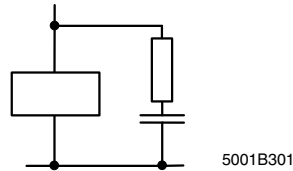

Figure 4-2 Relay coil with RC element

The following values are recommended for the purpose of dimensioning the RC element:
 $R = 100 \Omega$ to 200Ω ; $C = 220 \text{ nF}$ to 470 nF .

4.1.3 Grounding concept

Axioline E devices operate in the low-level signal voltage range. In the case of low-level signal devices, interference is discharged via functional earth ground (FE). Functional earth ground (FE) is only used to discharge interference. It does not provide shock protection for people. Functional earth grounding is crucial for interference-free operation!

The Axioline E devices are designed to be screwed onto on a flat mounting surface.

Axioline E master

Ground the plastic master by means of the mounting screws of the fixing clips, see page 30.

Ground the metal master by means of the mounting screws of the fixing clips or the mounting plate or the DIN rail, see page 31.

Axioline E IO-Link digital input and output device

Implement the FE connection via the grounding lug in order to ensure noise immunity.

Axioline E IO-Link/analog converter

In environments with high levels of interference, in particular, Phoenix Contact recommends connecting the converter (Straight and rectangular version) to an appropriate functional earth ground point using an M4 screw, see page 50.

Ground the AXL E IOL TC4/K M12 device by means of the mounting screws of the fixing clips.

4.2 Installation instructions



NOTE: Damage to the electronics

The device contains components that can be damaged or destroyed by electrostatic discharge. When handling the device, observe the necessary safety precautions against electrostatic discharge (ESD) according to EN 61340-5-1 and IEC 61340-5-1.



NOTE: Damage to the electronics

The device may only be installed and removed by qualified electricians in accordance with the ESD regulations.



NOTE: Data corruption or loss

Implement the FE connection via mounting screws in order to ensure noise immunity.



NOTE: Damage to the electronics

To ensure IP65/IP67 protection, seal unused connections with protective caps.



NOTE: Damage to the electronics

Only supply the sensors with voltage U_S which is provided at the terminal points.



NOTE: Damage to the electronics

Avoid polarity reversal of supply voltages U_S and U_A .

4.3 Mounting distances

No specific distances are required between devices or between a device and a cabinet door or cover. Mounting distances are determined solely by the plugs used and the bending radii of the cables.

4.4 Mounting Axioline E plastic devices

- Screw the device directly onto the flat mounting surface using the drill holes (1) of the fixing clips.

Drill hole spacing

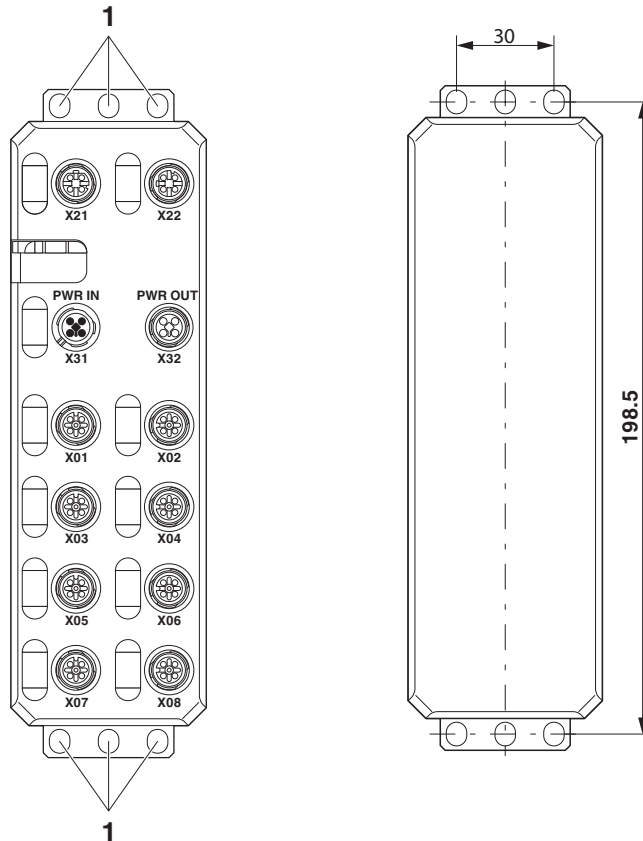

Figure 4-3 Mounting



Use standard M5 screws with toothed lock washer and self-locking nuts. Observe the maximum torque of the screws.

Functional earth grounding



NOTE: Data corruption or loss

Functional earth grounding is crucial for interference-free operation. Ground the device by means of the mounting screws of the fixing clips.

4.5 Mounting Axioline E metal devices

There are two options for mounting the metal devices. You can:

- Screw the device to the extendable fixing clips
- Mount the device using a mounting plate

4.5.1 Mounting metal devices using extendable fixing clips

A fixing clip is located on the back of the metal device at the top and bottom.

- Extend the fixing clips.
- Screw the device directly onto a flat mounting surface using the fixing clips.

Fixing clips of the metal device

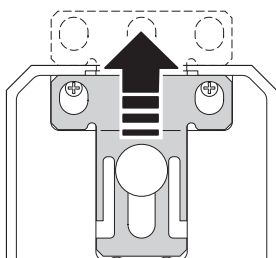

Figure 4-4 Extending the fixing clips of the metal device

Drill hole spacing

Please refer to the diagram below for the drill hole spacing.

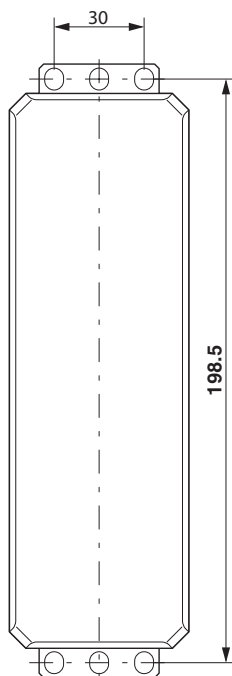

Figure 4-5 Drill hole spacing

Functional earth grounding



NOTE: Data corruption or loss

Functional earth grounding is crucial for interference-free operation. Ground the device by means of the mounting screws of the fixing clips

4.5.2 Attaching the metal device using a mounting plate

You can order the mounting plate for metal devices from Phoenix Contact under Order No. 2701761.

- Screw the mounting plate directly onto a flat mounting surface using the mounting holes provided or snap the mounting plate onto a DIN rail..



Use standard M5 screws with toothed lock washer and self-locking nuts. Observe the maximum torque of the screws.

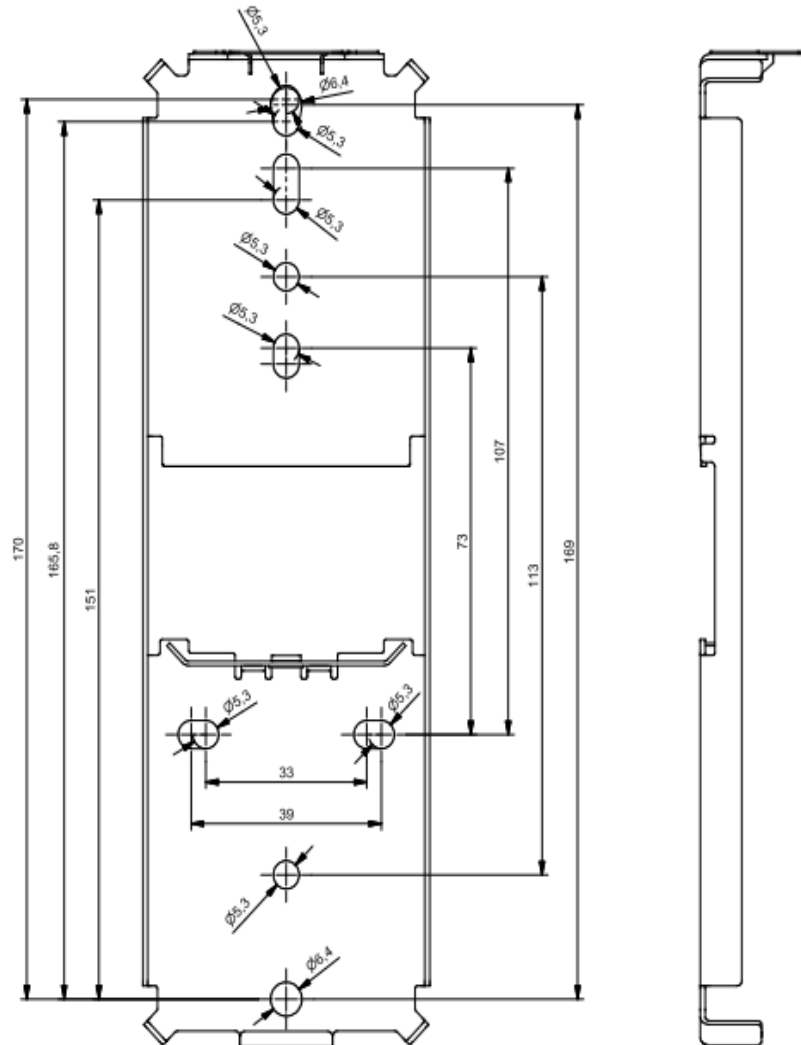

Figure 4-6 Mounting plate

Mounting Axioline E devices and connecting cables

- Proceed as illustrated below when snapping the metal device onto the mounting plate (A1, A2) and removing it (B1, B2).

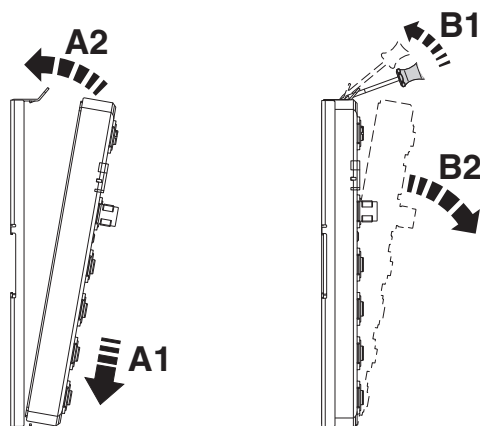

Figure 4-7 Snapping on and removing the metal device from the mounting plate

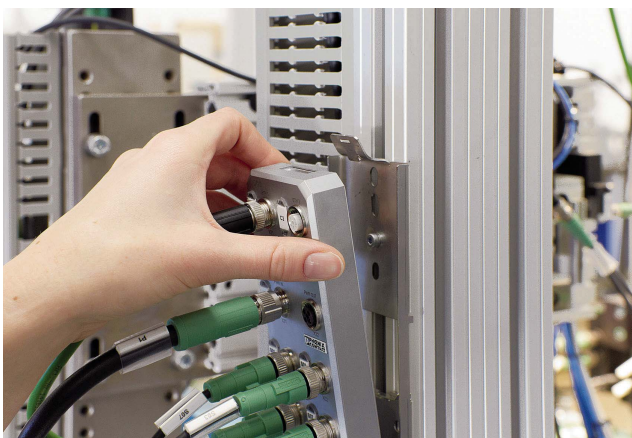

Figure 4-8 Snapping the metal device onto the mounting plate

Functional earth grounding



NOTE: Data corruption or loss

Functional earth grounding is crucial for interference-free operation. Ground the device by means of the mounting screws of the fixing clips or the mounting plate or the DIN rail.

4.6 Configuration via rotary coding switches

The Axioline E devices have rotary coding switches, which are located below a cover, see figure.

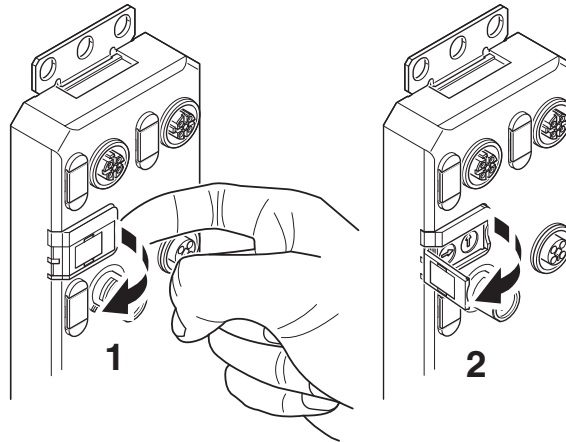

Figure 4-9 Opening the rotary coding switch cover



Adjust the rotary coding switches using a suitable screwdriver (according to DIN 5264: blade width 3.0 mm or 2.5 mm). Using an unsuitable tool may damage the rotary coding switches.



After modifying the switch position, restart the device, as the modification to the switch position does not take effect during operation.



Further information on the rotary coding switches can be found in the device-specific data sheet.

4.7 Cable connection

Phoenix Contact recommends using the SPEEDCON fast locking system to connect M12 cables. The fast locking system is quick to install as it is based on the principle of “Plug & Turn”. With just a half turn you can create the perfect plug-in connection. The SPEEDCON fast locking system is 100% compatible with all M12 connectors.



Figure 4-10 Connecting M12 connectors



Figure 4-11 Axioline E device with connected M12 connectors

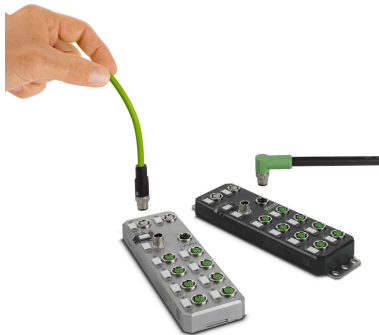

Figure 4-12 Connectors in straight and angled format

4.8 Connecting power supplies

For Axioline E devices, a distinction is made between two voltages:

- U_S to supply the communications power and the sensors (always required)
- U_A for supplying the actuators, only required for devices with fixed outputs or for additional devices

Connection

All supply voltages are connected via M12 connectors.

Current carrying capacity



NOTE: Damage to the electronics

Connect both supply voltages completely (to +24 V and GND). Do not connect several supply voltages via one GND, as this will exceed the current carrying capacity of the contacts.

4.8.1 Power supplies U_S and U_A

Voltages U_S and U_A are fed in at connection X31.

Power supply U_S is required to supply the communications power of the device electronics and to supply the sensors. It must be connected to every device. If this supply voltage is disconnected, the device will not work.

Install the power supply for the device electronics independently of the power supply for the actuators. Protect the power supplies independently. This means that the bus can continue running even if some I/O devices are switched off.



Figure 4-13 Voltage feed U_S and U_A

Mounting Axioline E devices and connecting cables

Power supply U_S for AXL E devices

Connect power supply U_S for the logic and sensors to socket X31. To supply additional devices, connect the cable for the outgoing supply voltage to socket X32.



NOTE: Damage to the electronics

The current carrying capacity of the M12 connectors is 12 A per contact. Make sure that this value is not exceeded. Please note that the connection for the outgoing supply voltage is not monitored for overload. If the permissible current carrying capacity is exceeded, this may result in damage to the connectors.



Phoenix Contact recommends using pre-assembled cables.

Power supply U_A for AXL E devices

Power supply U_A is required to supply the actuators. It is only connected to devices with outputs or is required for additional devices.

When determining the load for a supply voltage, take into account the number of outputs, the nominal current, and the simultaneity.

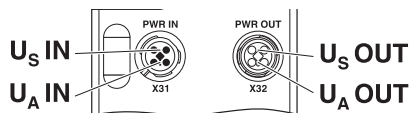

Figure 4-14 Connections U_S and U_A

Pin assignment of power supplies U_S and U_A

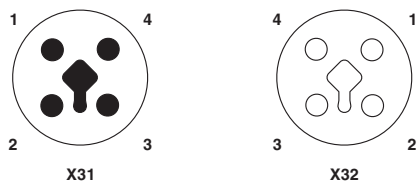

Figure 4-15 Power supplies U_S and U_A

Pin	IN	OUT	Wire colors
1	+24 V DC (U_S)	+24 V DC (U_S)	Brown
2	GND (U_A)	GND (U_A)	White
3	GND (U_S)	GND (U_S)	Blue
4	+24 V DC (U_A)	+24 V DC (U_A)	Black



NOTE: Damage to the electronics

Power supplies U_S and U_A should only be supplied with SELV.

4.8.2 Power supply for sensors and actuators of individual devices



The following diagram provides an **example** of which inputs or outputs are supplied by which supply voltage.

For the actual assignment for your device, please refer to the device-specific data sheet.

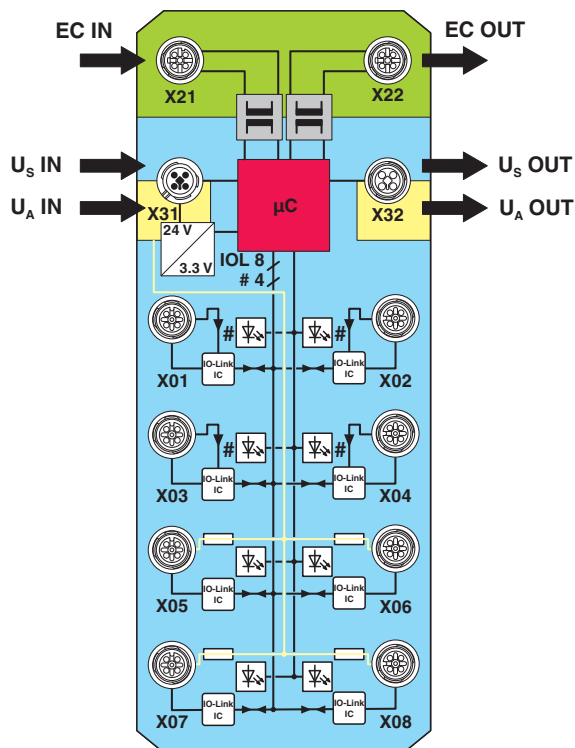

Figure 4-16 Supply of inputs and outputs digital input and output device, e.g., AXL E EC DI8 DO8 M12 6M

- Key:
- Green area: network/bus
 - Blue area: U_S
 - Yellow area: U_A

4.8.3 Examples for voltage supply



NOTE: Damage to the electronics

The total current at U_S must not exceed 12 A.

The total current at U_A must not exceed 12 A.

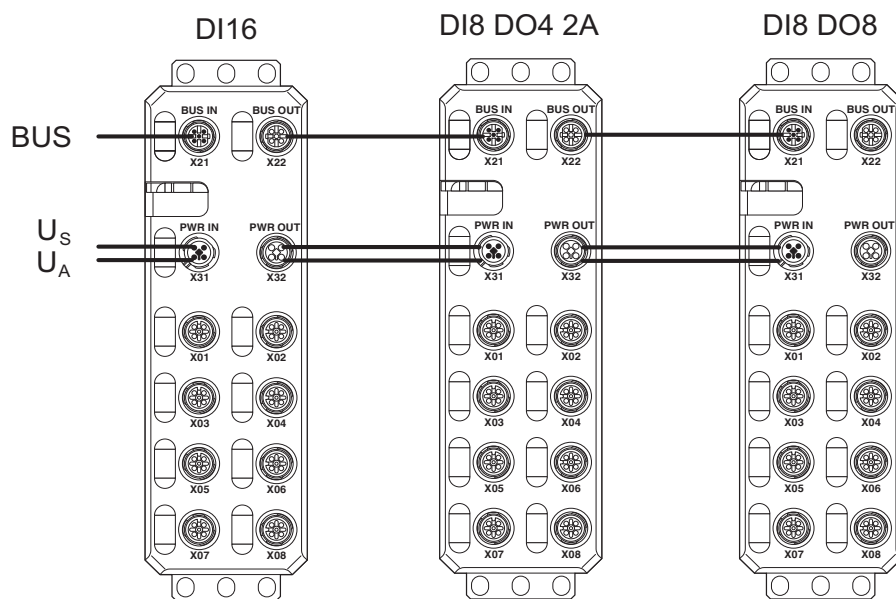

Figure 4-17 Example for the supply and forwarding of supply voltages

4.8.4 Supply line and power supply (M12)

For M12 connectors in Axioline E devices, a maximum of **12 A per contact** is permitted.

To ensure that this condition is met, the following factors must be considered:

1. Current consumption of the Axioline E devices (see data sheets)
2. Current consumption of the connected sensors
3. Current consumption of the connected actuators
4. Length of the cables and losses on these cables



It is particularly important that these factors are observed when forwarding the supply voltage.

4.8.5 Calculation example for sensor and actuator currents

The calculation example applies to the assignment of one signal per port.

Calculation example for an AXL E DI8 DO8 device

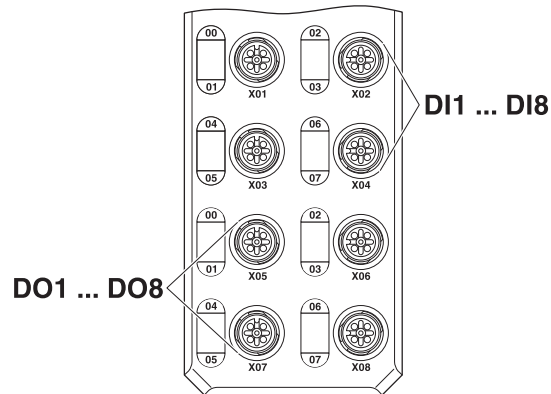

Figure 4-18 AXL E PB DI8 DO8 M12 6P

Type of sensor:

1 x reflex photoelectric barrier with 2 output signals
2 x proximity switch

Current consumption:

30 mA
15 mA each

Type of actuator:

2 x solenoid valve (hydraulic)
2 x solenoid valve (pneumatic)

1.3 A each
67 mA each

Calculation example for an AXL E DI8 DO8 device

U_S	Installation consumption		165 mA
X01, X02	Reflex photoelectric barrier	+	30 mA
X03	Proximity switch	+	15 mA
X04	Proximity switch	+	15 mA
Sensor supply			= 225 mA
Current consumption of inputs (5 mA for each input used)			+ 20 mA
I_U total			= 245 mA

Current consumption of actuators U_A

U_A	Installation consumption		30 mA
X05	2 x 1.3 A solenoid valve (hydraulic)	+	2.6 A
X06	2 x 67 mA solenoid valve (pneumatic)	+	134 mA
I_{UA} total			= 2.764 A

With this wiring, the device loads U_S with approximately 245 mA and U_A with approximately 2.764 A.

Losses on cables

The voltage drop on the cables can be calculated using the following formula:

$$U_A = I \times R \times 2$$

Where:

U_A	Voltage drop
I	Current strength
R	Conductor resistance
2	Calculation for forward and return path

For a power supply cable of $4 \times 0.75 \text{ mm}^2$, cable type 186 (e.g., SAC-4P-M12MS/...-186/M12FS), the conductor resistance is $26 \text{ } \Omega/\text{km}$.

At 4 A:

$$U_A = 4 \text{ A} \times 26 \text{ } \Omega/\text{km} \times 2 = 208 \text{ V/km} \quad \text{which corresponds to } 2.08 \text{ V on } 10 \text{ m}$$

At 2 A:

$$U_A = 2 \text{ A} \times 26 \text{ } \Omega/\text{km} \times 2 = 104 \text{ V/km} \quad \text{which corresponds to } 1.04 \text{ V on } 10 \text{ m}$$

Other cables have other specific resistance values. These values can be used to calculate the voltage drop according to the above formula.

4.9 Connecting sensors and actuators

Connect the sensors and actuators using M12 connectors.

**NOTE: Damage to the electronics**

In general, the maximum current load of 4 A per contact must not be exceeded.



For the pin assignment of inputs and outputs, please refer to the device-specific data sheet.



Phoenix Contact recommends using pre-assembled cables.

UM EN AXL E SYS INST

5 Axioline E IO-Link devices

IO-Link system

With IO-Link, you exchange data from the controller to the lowest field level. IO-Link is the first, globally standardized IO technology (IEC 61131-9) to communicate with sensors and actuators. An IO-Link system consists of an IO-Link master and one or more IO-Link devices. IO-Link is a point-to-point communication.

Axioline E IO-Link master

The Axioline E IO Link master provides the interface to the superimposed control (PLC) and controls the communication with the connected IO-Link devices. The Axioline E product portfolio is for each of the networks listed in the figure below IO-Link master available.

Axioline E IO-Link device

The Axioline E IO-Link devices solve the customer's request to capture or output various digital or analog I/O signals as flexibly as possible via IO-Link.

The following figure shows the use of different Axioline E-IO-Link devices in different networks.

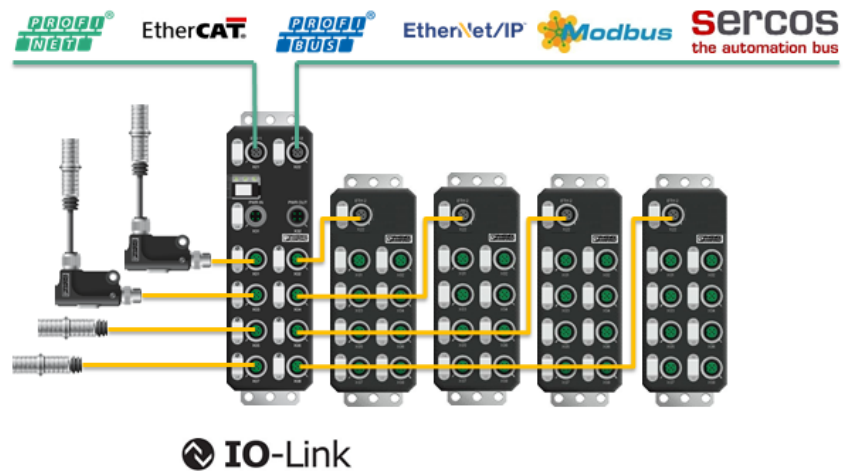

Figure 5-1 Exemplary Axioline E IO-Link topology

UM EN AXL E SYS INST

**Device description file
IO Device Description
(IODD)**

For each Axioline E IO-Link device, there is device-specific information in the form of a device description file. It contains information on identification, device parameters, process and diagnostic data, communication properties, and the structure of the user interface in engineering tools. The engineering tool can easily read and process this information. Both about the IODD as well as about a IO-Link device internal device ID, you can identify any Axioline E IO-Link device type.

To ensure that the parameter data of an Axioline E IO-Link device are not lost during the device exchange, it is possible to store them automatically directly in the Axioline E IO-Link master. If a new, identical replacement device is connected, the parameters of the predecessor device are automatically transferred to the new Axioline E IO-Link device. Changing parameters can, for example, during operation by the PLC.

The current IODD file is available for download at the address phoenixcontact.net/products.

5.1 Axioline E IO-Link master

Der Axioline E IO-Link master enables the operation of up to eight IO-Link sensors/actuators and is also used to acquire digital signals. By using the various operating modes of an IO-Link port, the following operating modes can be operated:

- Digital standard signal.
- Analogue signals in combination with IO-Link/analog converters
- IO-Link device communication, flow sensors, valve inserts, light barriers or distance meters

With the multifunctional IO-Link ports, an IO-Link master becomes a universal I/O device. In conjunction with the IO-Link /analog converters, a perfect solution scenario results for the multifaceted advent of analog signals. Together with the IO-Link/analog converters, the devices allow flexible processing of the signal volume in the field installation.



Figure 5-2 IO-Link A ports (A) und IO-Link B ports (B) of an AXL E IO-Link masters



Ensure that the voltage supply U_A and the power supply U_S are made from two independent, galvanically isolated power supplies.



NOTE: Sensors damage

When connecting an IO-Link type A sensor to an IO-Link B port, note that a voltage is applied to pin 2 and pin 5. Do not connect it to the sensor.

Use a three-wire cable between port and sensor, e.g., cable type SAC-3P-M12MS/.../... Order No. 1696662.

5.2 Axioline E IO-Link digital input and output devices

The Axioline E product group is supplemented by IO-Link digital input and output devices. These are designed as plastic variants. The IO-Link technology offers the advantage that IO-Link master can be used as an IO-Link port for communication with the IO-Link digital input and output devices.

The IO-Link technology is also used to provide the sensor supply (IO-Link A port, L +) and, if necessary, the actuator supply (IO-Link B port, L + and U_A).

Axioline E digital input device

The Axioline E digital input device is connected to an IO-Link master via an IO-Link A port. It is used to acquire digital signals via IO-Link. The IO-Link master allows the use within different networks, see page 7.

Axioline E digital output device

The Axioline E digital output device is connected to an IO-Link master via an IO-Link B port. It is used to output digital signals via IO-Link. The IO-Link master allows the use within different networks, see page 7.

5.2.1 Housing dimensions of the Axioline E IO-Link digital input and output devices

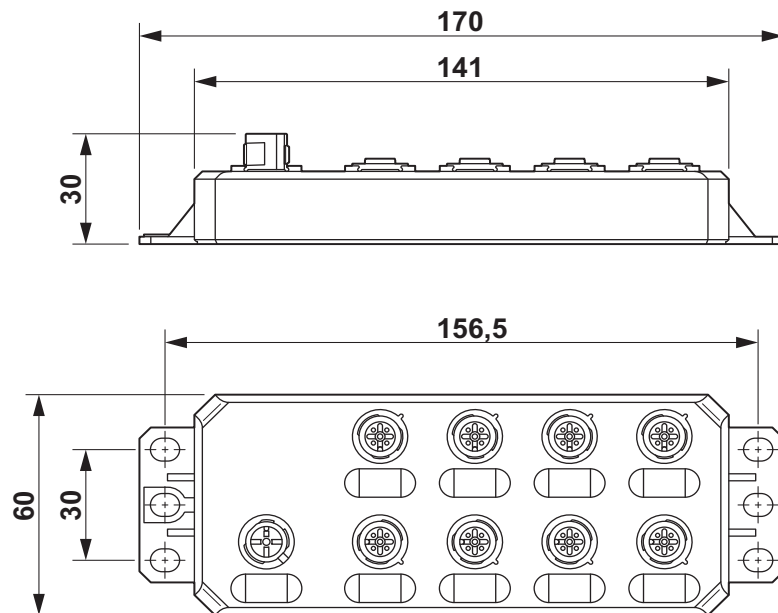

Figure 5-3 Housing dimensions (mm) of the Axioline E IO-Link digital input and output devices

5.2.2 Basic structure of the Axioline E IO-Link digital input and output devices

The figure shows the basic structure of the Axioline E IO-Link digital input and output devices.

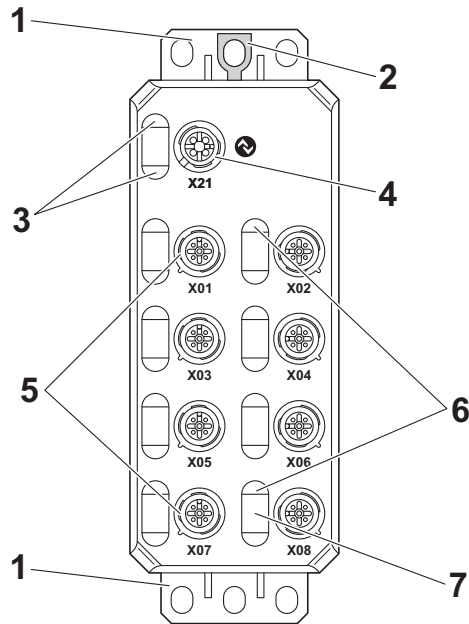

Figure 5-4 Basic structure of the Axioline E IO-Link digital input and output devices

- 1 Fixing clips
- 2 FE connection)
- 3 Status indicators of the IO-Link port
- 4 IO-Link A port (digital input device)
IO-Link B port (digital output device)
- 5 Connections of the IO-Link ports (inputs or outputs)
- 6 Status indicators of the IO-Link port (inputs or outputs)
- 7 Markers for marking

5.2.3 Marking of the Axioline E IO-Link digital input and output devices

It is possible to mark the devices next to the ports (7 in Figure 5-4) zu beschriften. The devices are supplied as standard with nine unprinted marking labels. If you want to swap a label, you can lift it out of the recess using a screwdriver.

Phoenix Contact offers the CMS-MARK-WIN software for professional marking, see Phoenix Contact catalog.

5.2.4 Diagnostic and status indicators of the Axioline E IO-Link digital input and output devices

Diagnostics

The diagnostics indicators (green/yellow/red) indicate whether an error is present or not. In the event of an error, they indicate the error type and location.

An Axioline E IO-Link digital input and output device works properly when all green indicators light/flash.

Status

The status indicators (yellow/red) indicate the signal state of the corresponding IO-Link port (input/output).



For more detailed information on the diagnostics and status indicators, please refer to the data sheet for the respective device.

5.2.5 Mounting of the Axioline E IO-Link digital input and output devices

Screw the devices tightly down onto a flat surface using the fixing clips (1 in Figure 5-5). Ground the devices by means of the grounding lug (2 in Figure 5-5).



Use standard M5 screws with toothed lock washer. Observe the maximum torque of the screws.

Drill hole spacing

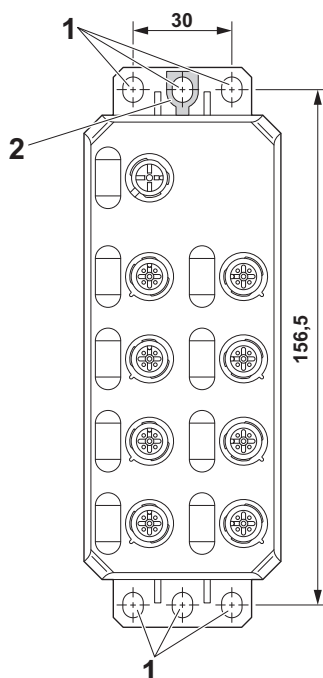

Figure 5-5 Mounting of the Axioline E IO-Link digital input and output devices

Functional earth grounding



NOTE: Data corruption or loss

Functional earth grounding is crucial for interference-free operation. Ground the devices by means of the grounding lug.



For more information on the installation, please refer to the packing slip and the chapters 4.1, 4.2 und 4.3.

Connecting cables

Then connect the cables, see page 36.

5.3 IO-Link/analog converter

The IO-Link/analog converter is an IO-Link device that converts analog signals into the IO-Link protocol. Depending on the version, the IO-Link/analog converter offers you the possibility to capture the signals from analog sensors via an IO-Link master or to transmit them to analog actuators. Conversion of analog signals directly at the measurement location and digital transmission via unshielded cables simplify installation and result in interference-free transmission of measured values.

The IO-Link/analog converters are designed as plastic versions. The IO-Link/analog converters can be supplied in straight or rectangular format.

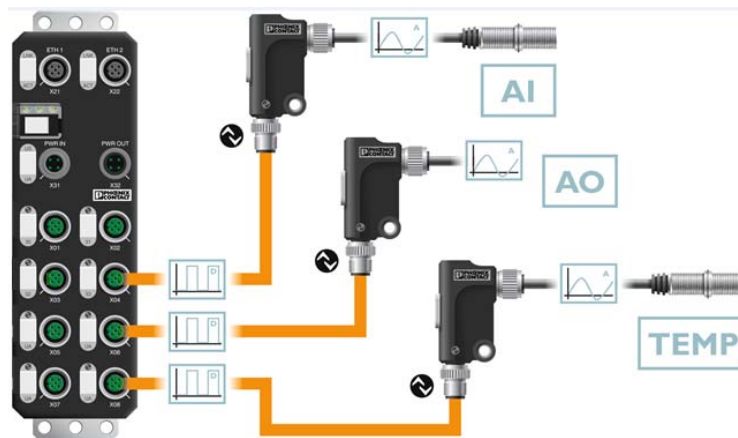

Figure 5-6 Analog data acquiring/transmitting

Axioline E IO-Link devices

In conjunction with the IO link masters, this results in a perfect solution scenario for the multifaceted advent of analog signals.

An IO-Link/analog converter is either connected directly to an analog sensor or placed in the immediate vicinity of the analog sensor. Thus, expensive, shielded cables between an analog sensor and the IO-Link master can be significantly reduced or even completely saved.



Figure 5-7 IO-Link/analog converter and Axioline E IO-Link master

5.3.1 Dimensions of the straight IO-Link/analog converter

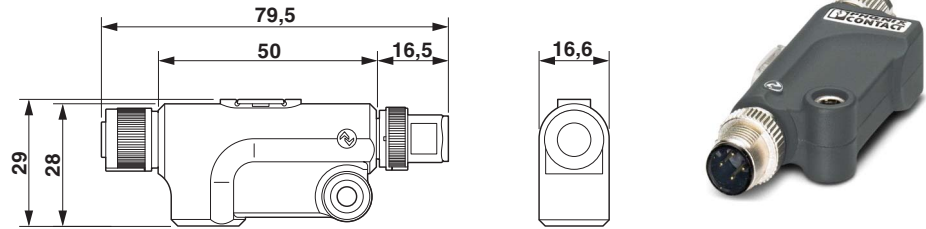

Figure 5-8 Dimensions in mm

5.3.2 Dimensions of the rectangular IO-Link/analog converter

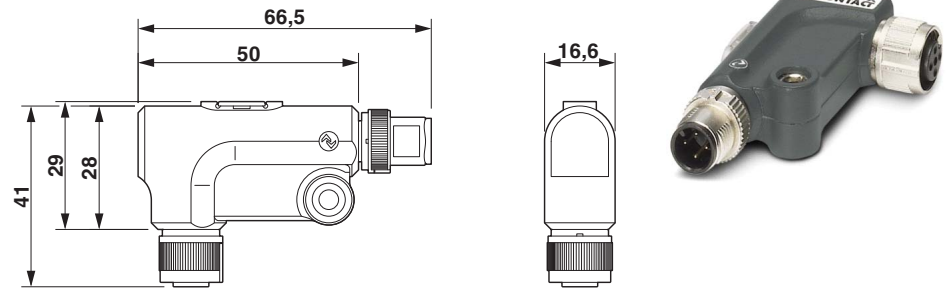

Figure 5-9 Dimensions in mm

5.3.3 Connections of the straight IO-Link/analog converter

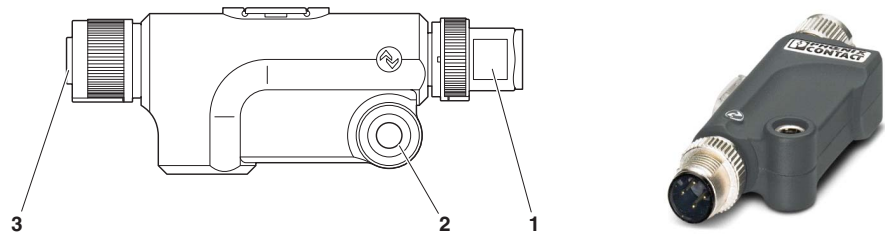

Figure 5-10 Connections on the converter

1. IO-Link interface (indicated by IO-Link symbol)
2. Fixing options; options for connection to functional earth ground
3. Analog input/output

5.3.4 Connections of the rectangular IO-Link/analog converter

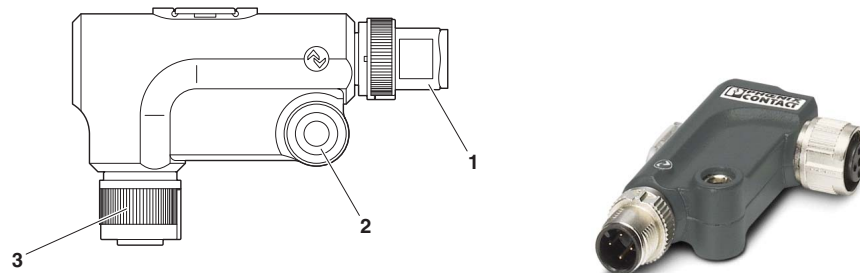

Figure 5-11 Connections on the converter

1. IO-Link interface (indicated by IO-Link symbol)
2. Fixing options; options for connection to functional earth ground
3. Analog input/output

5.3.5 Mounting of the IO-Link/analog converter

- Verbinden Sie die IO-Link-Schnittstelle des Konverters mittels einer standardisierten 3-poligen Leitung mit einem IO-Link-Port des übergeordneten IO-Link-Masters.
- Schließen Sie den analogen Sensor direkt oder mittels einer geschirmten 4-poligen Leitung am analogen Eingang des Konverters an.
- Verschrauben Sie die Anschlüsse jeweils mittels der M12-Steckverbinder.

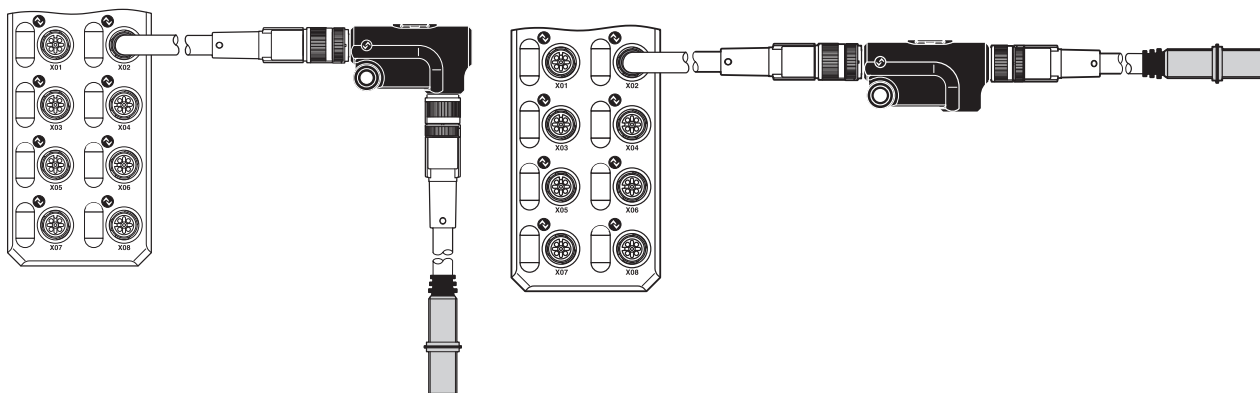

Figure 5-12 Connection of a sensor to an IO-Link master via a rectangular/straight converter



NOTE: Data corruption or loss

In environments with high levels of interference, in particular, Phoenix Contact recommends connecting the converter to an appropriate functional earth ground point using an M4 screw.

Mount the converter as close as possible to the sensor. The cable length may not exceed 30 m.



For more information, please refer to the device-specific data sheets.

5.4 IO-Link/analog converter (AXL E IOL TC4/K M12 device)

The Axioline E IO-Link/analog converter is an IO-Link device that transmits analog signals from thermocouples (TC) via the IO-Link-protocol. The device is connected to an IO-Link master via an IO-Link A port. Via the IO-Link master the use within different networks is possible.



Figure 5-13 AXL E IOL TC4/K M12 device

5.4.1 Dimensions of the AXL E IOL TC4/K M12 device

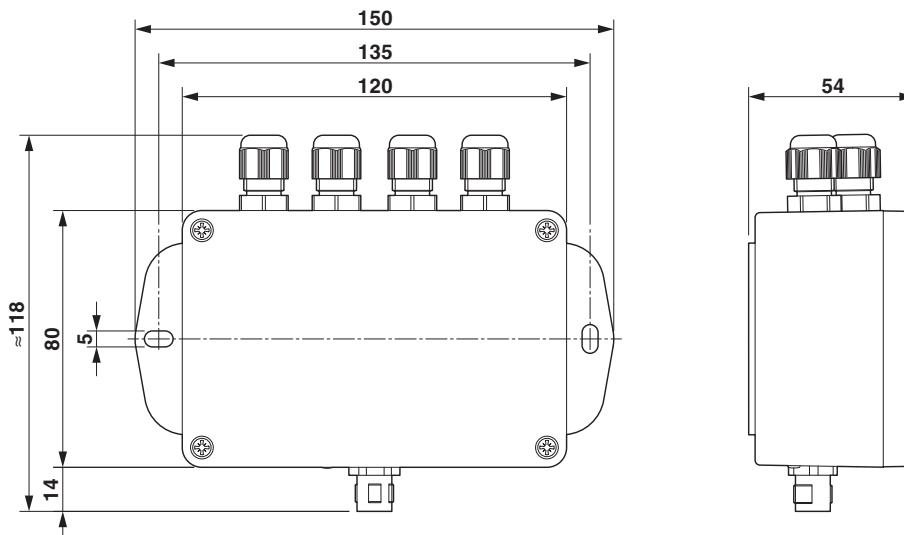

Figure 5-14 Dimensions in mm

5.4.2 Connection and display of the AXL E IOL TC4/K M12 device

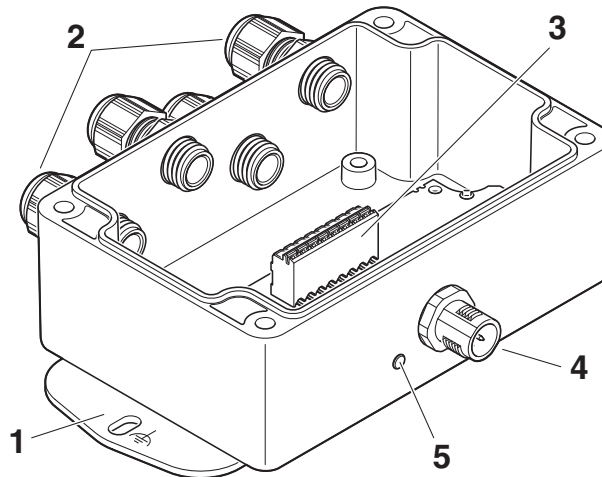

Figure 5-15 Connections and display

1. Mounting plate/Functional earth ground
2. Cable glands for TC inputs
3. TC inputs
4. IO-Link A port
5. COM-LED

5.4.3 Mounting of the AXL E IOL TC4/K M12 device

- Refer to Figure 5-14 for the dimensions of the device and the drill hole spacing.
- Take the placed-on cover off of the device.
- Screw the module tightly down onto a flat surface using the fixing clips (1).
- Ensure a conductive connection to the functional earth ground.
- Connect the cable for the IO-Link A port (4) by way of an M12 connector. Phoenix Contact recommends using the SPEEDCON fast locking system to connect M12 cables.
- Connect the cables for the TC inputs (3) by way of Push-in technology.



You can use a shield braid clip for the connection of shielded TC cables. The AXL E TC4 SHIELD SET, Order No. 1065793, contains five shield braid clips. Only one shield bracket is required per Axioline E IOL TC4/K M12 device. The mounting by means of the shield braid clip is described in the packing slip of the AXL E TC4 SHIELD SET. For more detailed information on the AXL E IOL TC4/K M12 device, please refer to the data sheet.

5.5 Axioline E IO-Link topology

The following figure shows Axioline E IO-Link devices in a PROFINET network.

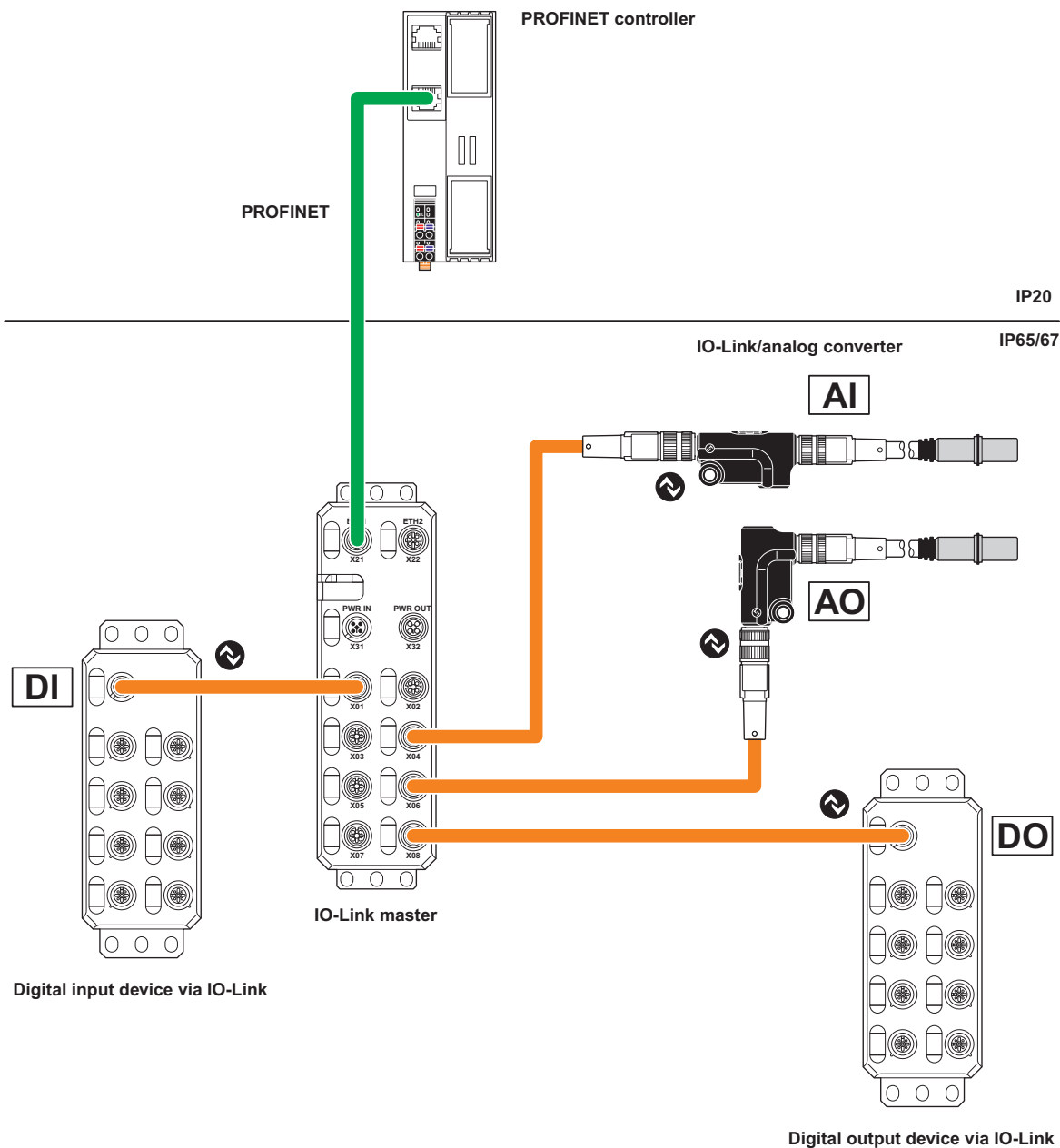

Figure 5-16 Example Axioline E IO-Link topology

UM EN AXL E SYS INST

Please observe the following notes

General terms and conditions of use for technical documentation

Phoenix Contact reserves the right to alter, correct, and/or improve the technical documentation and the products described in the technical documentation at its own discretion and without giving prior notice, insofar as this is reasonable for the user. The same applies to any technical changes that serve the purpose of technical progress.

The receipt of technical documentation (in particular user documentation) does not constitute any further duty on the part of Phoenix Contact to furnish information on modifications to products and/or technical documentation. You are responsible to verify the suitability and intended use of the products in your specific application, in particular with regard to observing the applicable standards and regulations. All information made available in the technical data is supplied without any accompanying guarantee, whether expressly mentioned, implied or tacitly assumed.

In general, the provisions of the current standard Terms and Conditions of Phoenix Contact apply exclusively, in particular as concerns any warranty liability.

This manual, including all illustrations contained herein, is copyright protected. Any changes to the contents or the publication of extracts of this document is prohibited.

Phoenix Contact reserves the right to register its own intellectual property rights for the product identifications of Phoenix Contact products that are used here. Registration of such intellectual property rights by third parties is prohibited.

Other product identifications may be afforded legal protection, even where they may not be indicated as such.

How to contact us

Internet

Up-to-date information on Phoenix Contact products and our Terms and Conditions can be found on the Internet at:

phoenixcontact.com

Make sure you always use the latest documentation.

It can be downloaded at:

phoenixcontact.net/products

Subsidiaries

If there are any problems that cannot be solved using the documentation, please contact your Phoenix Contact subsidiary.

Subsidiary contact information is available at phoenixcontact.com.

Published by

PHOENIX CONTACT GmbH & Co. KG

Flachmarktstraße 8

32825 Blomberg

GERMANY

PHOENIX CONTACT Development and Manufacturing, Inc.

586 Fulling Mill Road

Middletown, PA 17057

USA

Should you have any suggestions or recommendations for improvement of the contents and layout of our manuals, please send your comments to:

tecdoc@phoenixcontact.com



SCATTERGOOD & JOHNSON LTD

ELECTRICAL ENGINEERING & FLUID CONTROL DISTRIBUTORS

Est.1899

At Scattergood & Johnson Ltd, we pride ourselves on being a technical distributor to specialist industries.

Working with a range of quality product suppliers across a number of specialist markets, we are not your average 'box shifter' - we are your technical and supply chain partner.

We fully support every product we sell - for free! Our internal team and external sales engineers can answer any product or application question, no matter the complexity.

Backing up this technical ability is a range of 50,000+ products available from stock for nationwide next day delivery (same day if required!), or you can collect what you need from any of our trade counters around the UK.

Select your specialist interest below to learn more about how we can help.

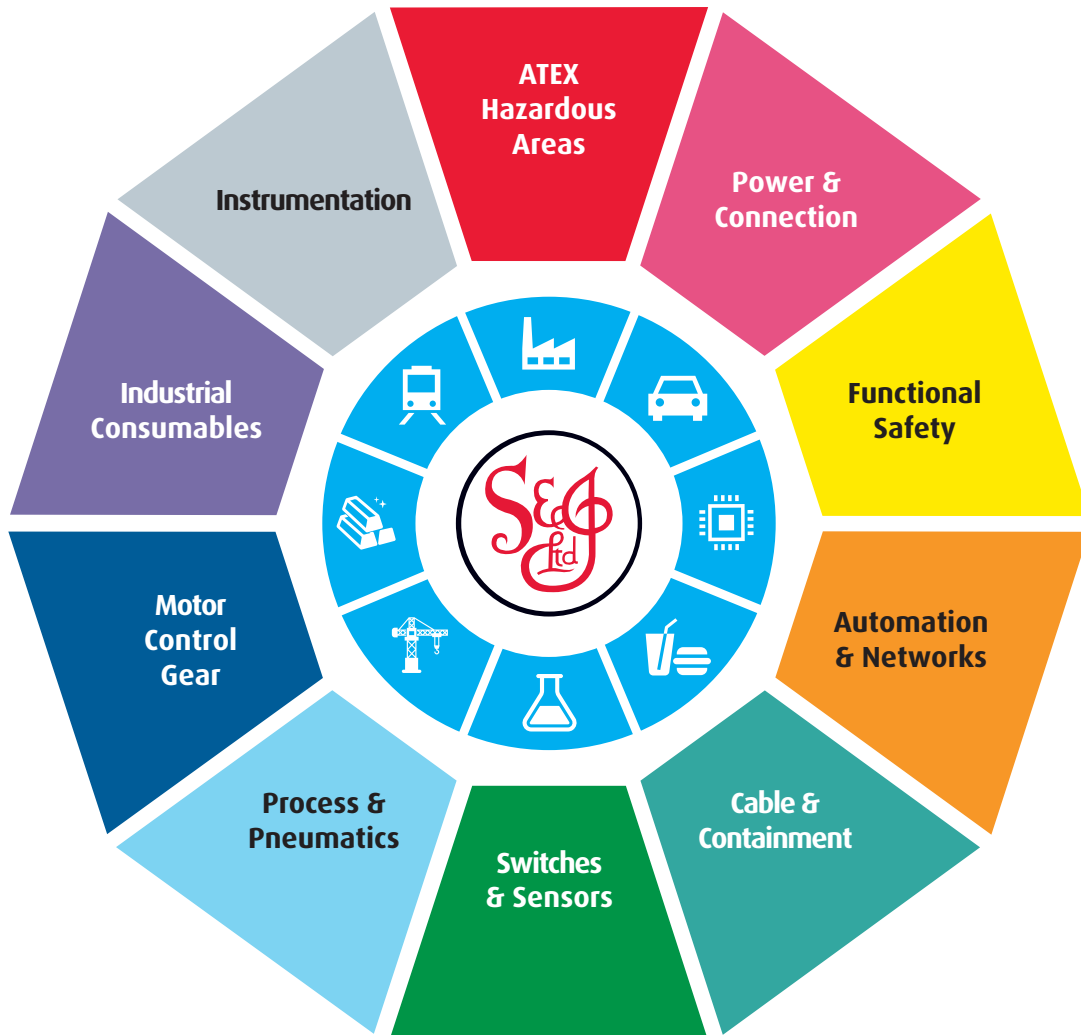

Online, In Branch and On the Road - Scattergood & Johnson Ltd, there when you need us.

www.scatts.co.uk