

User manual

UM EN IB IL 24 LPSDO 8 V2-PAC

Inline module with integrated safety logic and safe digital outputs

User manual

Inline module with integrated safety logic and safe digital outputs

2019-08-07

Designation: UM EN IB IL 24 LPSDO 8 V2-PAC

Revision: 05

This user manual is valid for:

Designation	Order No.	From Revision
IB IL 24 LPSDO 8 V2-PAC	2700606	HW/FW/FW: 00/100/100

Please observe the following notes

Please observe the following notes

In order to ensure the safe use of the product described, you have to read and understand this manual. The following notes provide information on how to use this user manual.

User group of this manual

The use of products described in this manual is oriented exclusively to qualified electricians or persons instructed by them, who are familiar with applicable national standards and other regulations regarding electrical engineering and, in particular, the relevant safety concepts.

Phoenix Contact accepts no liability for erroneous handling or damage to products from Phoenix Contact or third-party products resulting from disregard of information contained in this user manual.

Explanation of symbols used and signal words



This is the safety alert symbol. It is used to alert you to potential personal injury hazards. Obey all safety measures that follow this symbol to avoid possible injury or death.



DANGER

This indicates a hazardous situation which, if not avoided, will result in death or serious injury.



WARNING

This indicates a hazardous situation which, if not avoided, could result in death or serious injury.



CAUTION

This indicates a hazardous situation which, if not avoided, could result in minor or moderate injury.

The following types of message provide information about possible property damage and general information concerning proper operation and ease of use.



NOTE

This symbol and the accompanying text alert the reader to a situation which may cause damage or malfunction to the device, hardware or software, or surrounding property.



This symbol and the accompanying text provide the reader with additional information, such as tips and advice on the efficient use of hardware and on software optimization. It is also used as a reference to other sources of information (manuals, data sheets) on the subject matter, product, etc.

Please observe the following notes

General terms and conditions of use for technical documentation

Phoenix Contact reserves the right to alter, correct, and/or improve the technical documentation and the products described in the technical documentation at its own discretion and without giving prior notice, insofar as this is reasonable for the user. The same applies to any technical changes that serve the purpose of technical progress.

The receipt of technical documentation (in particular data sheets, installation instructions, manuals, etc.) does not constitute any further duty on the part of Phoenix Contact to furnish information on alterations to products and/or technical documentation. Any other agreement shall only apply if expressly confirmed in writing by Phoenix Contact. Please note that the supplied documentation is product-specific documentation only and that you are responsible for checking the suitability and intended use of the products in your specific application, in particular with regard to observing the applicable standards and regulations. Although Phoenix Contact makes every effort to ensure that the information content is accurate, up-to-date, and state-of-the-art, technical inaccuracies and/or printing errors in the information cannot be ruled out. Phoenix Contact does not offer any guarantees as to the reliability, accuracy, or completeness of the information. All information made available in the technical data is supplied without any accompanying guarantee, whether expressly mentioned, implied or tacitly assumed. This information does not include any guarantees regarding quality, does not describe any fair marketable quality, and does not make any claims as to quality guarantees or guarantees regarding the suitability for a special purpose.

Phoenix Contact accepts no liability or responsibility for errors or omissions in the content of the technical documentation (in particular data sheets, installation instructions, manuals, etc.).

The aforementioned limitations of liability and exemptions from liability do not apply, in so far as liability must be assumed, e.g., according to product liability law, in cases of premeditation, gross negligence, on account of loss of life, physical injury or damage to health or on account of the violation of important contractual obligations. Claims for damages for the violation of important contractual obligations are, however, limited to contract-typical, predictable damages, provided there is no premeditation or gross negligence, or that liability is assumed on account of loss of life, physical injury, or damage to health. This ruling does not imply a change in the burden of proof to the detriment of the user.

Please observe the following notes

Statement of legal authority

This manual, including all illustrations contained herein, is copyright protected. Use of this manual by any third party is forbidden. Reproduction, translation, and public disclosure, as well as electronic and photographic archiving and modification require written consent by Phoenix Contact. Violators are liable for damages.

Phoenix Contact reserves all rights in the case of patent award or listing of a registered design. Third-party products are always named without reference to patent rights. The existence of such rights shall not be excluded.

How to contact us**Internet**

Up-to-date information on Phoenix Contact products and our Terms and Conditions can be found on the Internet at:

www.phoenixcontact.com.

Make sure you always use the latest documentation.

It can be downloaded at:

www.phoenixcontact.net/catalog.

Subsidiaries

If there are any problems that cannot be solved using the documentation, please contact your Phoenix Contact subsidiary.

Subsidiary contact information is available at www.phoenixcontact.com.

Published by

PHOENIX CONTACT GmbH & Co. KG
 Flachsmarktstraße 8
 32825 Blomberg
 GERMANY
 Phone +49 - (0) 52 35 - 3-00
 Telefax +49 - (0) 52 35 - 3-4 12 00

PHOENIX CONTACT
 P.O. Box 4100
 Harrisburg, PA 17111-0100
 USA
 Phone +1-717-944-1300

Should you have any suggestions or recommendations for improvement of the contents and layout of our manuals, please send your comments to:

tecdoc@phoenixcontact.com

Table of contents

1	For your safety	1-1
1.1	General safety notes.....	1-1
1.2	Electrical safety	1-3
1.3	Safety of the machine or system.....	1-4
1.4	Safety for starting applications.....	1-5
1.5	Directives and standards	1-5
1.6	Correct usage.....	1-6
1.7	Documentation	1-6
1.8	Abbreviations used	1-7
1.9	Safety hotline.....	1-7
2	Product description.....	2-1
2.1	Note about the system description	2-1
2.2	Brief description of the safety module.....	2-1
2.3	Structure of the safety module	2-2
2.4	Housing dimensions	2-2
2.5	Safe digital outputs	2-3
2.6	Connection options for actuators depending on the parameterization	2-5
2.7	Local diagnostic and status indicators	2-6
2.8	Safe state	2-8
2.8.1	Operating state	2-8
2.8.2	Error detection in I/O devices	2-8
2.8.3	Device errors	2-9
2.8.4	Parameterization errors	2-9
2.9	Process data words	2-10
2.10	Programming data/configuration data.....	2-10
2.10.1	Local bus	2-10
2.10.2	Other bus systems or networks	2-10
3	Inline potential and data routing, and Inline connectors	3-1
3.1	Inline potential and data routing.....	3-1
3.2	Supply voltage U_L	3-1
3.3	Supply voltage U_M	3-2
3.4	Terminal point assignment.....	3-4

IB IL 24 LPSDO 8-PAC

4	Assembly, removal, and electrical installation.....	4-1
4.1	Assembly and removal	4-1
4.1.1	Unpacking the module	4-1
4.1.2	General	4-1
4.1.3	Setting the DIP switches	4-2
4.1.4	Assembly and removal of the safety module	4-4
4.2	Electrical installation	4-6
4.2.1	Electrical installation of the Inline station	4-6
4.2.2	Electrical installation of the safety module	4-6
5	Parameterization of the safety module.....	5-1
5.1	Parameterization of the safety module in a SafetyBridge system	5-1
5.2	Parameterization of the safe outputs	5-2
5.3	Behavior of the outputs in the event of enabled switch-off delay for stop category 1	5-4
6	Connection examples for safe outputs.....	6-1
6.1	Explanation of the examples.....	6-1
6.2	Notes on the protective circuit for external relays/contactors (free running circuit).....	6-2
6.3	Measures required to achieve a specific safety integrity level	6-3
6.4	Single-channel assignment of safe outputs	6-5
6.5	Two-channel assignment of safe outputs	6-8
7	Startup and validation	7-1
7.1	Initial startup	7-1
7.2	Restart after replacing a safety module	7-3
7.2.1	Replacing a safety module	7-3
7.2.2	Restart	7-3
7.3	Validation.....	7-3
8	Errors: Messages and removal	8-1
8.1	Safe digital output errors.....	8-4
8.2	Supply voltage errors.....	8-5
8.3	General errors	8-5
8.4	Parameterization errors	8-6
8.5	Connection errors to satellites	8-7
8.6	Acknowledging an error.....	8-8

Table of contents

9	Maintenance, repair, decommissioning, and disposal	9-1
9.1	Maintenance.....	9-1
9.2	Repair.....	9-1
9.3	Decommissioning and disposal.....	9-1
10	Technical data and ordering data	10-1
10.1	System data	10-1
10.1.1	Inline	10-1
10.1.2	SafetyBridge system	10-1
10.2	IB IL 24 LPSDO 8 V2-PAC.....	10-1
10.3	Conformance with EMC Directive.....	10-6
10.4	Ordering data	10-7
10.4.1	Ordering data: Safety module	10-7
10.4.2	Ordering data: Accessories	10-7
10.4.3	Ordering data: Software	10-7
10.4.4	Ordering data: Documentation	10-7
A	Appendix: SafetyBridge system.....	A-1
A 1	The SafetyBridge system	A-1
A 1.1	SafetyBridge technology – Maximum flexibility and safety	A-1
A 1.2	Overview of SafetyBridge system features	A-2
A 1.3	Differences in SafetyBridge systems dependent upon which module with integrated safety logic is used	A-2
A 2	System topology.....	A-4
A 2.1	General topology	A-4
A 2.2	Network and controller requirements	A-5
A 2.3	Safe input and output devices	A-5
A 3	SafetyBridge address assignment	A-6
A 4	Operating modes and setting the DIP switches in the SafetyBridge system....	A-10
A 4.1	Module switch positions	A-10
A 4.2	SafetyBridge multiplexer mode	A-11
A 5	Process image.....	A-13
A 5.1	Structure of the process image	A-13
A 5.2	Description of the registers	A-17
A 6	Implementation of data flow between the standard controller and the safety modules	A-22
A 6.1	Implementation of data flow with a function block	A-22
A 6.2	Implementation of data flow without a function block	A-22
A 7	Enable principle.....	A-22

IB IL 24 LPSDO 8-PAC

A 8	Diagnostics.....	A-24
A 8.1	Error detection in I/O devices	A-24
A 8.2	Detection of device errors	A-25
A 8.3	Acknowledgment of error messages for satellites	A-25
A 9	Configuration, parameterization, and download	A-26
A 9.1	Configuration and parameterization using the SAFECNF tool	A-26
A 9.2	Downloading the configuration and parameter data record following power up	A-27
A 10	Safe state	A-27
A 11	Time response in the SafetyBridge system	A-28
A 11.1	Typical response time	A-28
A 11.2	Shutdown times	A-29
A 12	Achievable safety depending on the modules used.....	A-30
A 13	Behavior in the event of an error.....	A-31
A 13.1	Critical system or device errors	A-31
A 13.2	Parameterization or configuration errors	A-32
A 13.3	Communication errors	A-32
A 13.4	I/O errors	A-32
A 14	Startup and restart.....	A-33
A 14.1	Startup/restart following power up	A-33
A 14.2	Restart after triggering a safety function	A-33
A 15	Memory sizes for the safety logic.....	A-33
B	Appendix: Checklists	B-1
B 1	Checklists for the SafetyBridge system	B-2
B 1.1	Planning	B-2
B 1.2	Configuration and parameterization	B-4
B 1.3	Startup	B-5
B 1.4	Safety functions	B-6
B 1.5	Validation.....	B-7
B 2	Checklists for the IB IL 24 LPSDO 8 V2-PAC module.....	B-8
B 2.1	Planning.....	B-8
B 2.2	Assembly and electrical installation	B-9
B 2.3	Startup	B-10
B 2.4	Validation	B-11
C	Appendix: Index.....	C-1
D	Appendix: Revision history	D-1

1 For your safety

Purpose of this manual

The information in this document is designed to familiarize you with how the IB IL 24 LPSDO 8 V2-PAC safety module works, its operating and connection elements, and its parameter settings. This information will enable you to use the module within a SafetyBridge system according to your requirements.

Validity of the user manual

This manual is only valid for the IB IL 24 LPSDO 8 V2-PAC module in the version indicated on the inner cover page.

1.1 General safety notes



WARNING: Depending on the application, incorrect handling of the safety module can pose serious risks for the user

When working with the safety module within the SafetyBridgesystem, please observe all the safety notes included in this section.

Requirements

Knowledge of the following is required:

- The target system (e.g., INTERBUS, PROFIBUS, PROFINET)
- The standard control system
- The SafetyBridge system (see Appendix A)
- The components used in your application
- The Inline product range
- Operation of the software tools used
- Safety regulations in the field of application

Qualified personnel

In the context of the use of the SafetyBridge system, the following operations may only be carried out by qualified personnel:

- Planning
- Configuration of the safety logic and parameterization
- Installation, startup, servicing
- Maintenance, decommissioning

This user manual is, therefore, aimed at:

- Qualified personnel who plan and design safety equipment for machines and systems and are familiar with regulations governing safety in the workplace and accident prevention
- Qualified personnel who install and operate safety equipment in machines and systems

In terms of the safety notes in this manual, qualified personnel are persons who, because of their education, experience and instruction, and their knowledge of relevant standards, regulations, accident prevention, and service conditions, have been authorized to carry out any required operations, and who are able to recognize and avoid any possible dangers.

IB IL 24 LPSDO 8 V2-PAC

Documentation	You must observe all information in this manual as well as in the documents listed in "Documentation" on page 1-6.
Safety of personnel and equipment	The safety of personnel and equipment can only be assured if the safety module is used correctly (see "Correct usage" on page 1-6).
Error detection	Depending on the wiring and the corresponding setting of the safe output module parameters, the SafetyBridge system can detect various errors within the safety equipment.
Do not carry out any repairs	Repair work may not be carried out on the safety module. In the event that an error cannot be removed, please contact Phoenix Contact immediately, engage a service engineer, or send the faulty module directly to Phoenix Contact.
Do not open the housing/security seal	It is strictly prohibited to open the safety module housing. In order to prevent the manipulation of the safety module and to detect the unauthorized opening of the safety module, a security seal is applied to the module. This security seal is damaged in the event of unauthorized opening. In this case, the correct operation of the safety module can no longer be ensured.
Measures to prevent incorrect connection and polarity reversal	Take measures to prevent the incorrect connection, polarity reversal, and manipulation of connections.

1.2 Electrical safety



WARNING: Hazardous body currents and the loss of functional safety

Disregarding instructions for electrical safety may result in hazardous body currents and the loss of functional safety.

In order to ensure electrical safety, please observe the following points.

Direct/indirect contact

Ensure that all components connected to the system are protected against direct and indirect contact according to VDE 0100 Part 410. In the event of an error, parasitic voltages must not occur (single-fault tolerance).

This can be achieved by:

- Using power supply units with safe isolation (PELV).
- Decoupling circuits, which are not SELV or PELV systems, using optocouplers, relays, and other components meeting the requirements of safe isolation.

Power supply unit for 24 V supply

Only use power supply units with safe isolation and PELV according to EN 50178/VDE 0160 (PELV). This prevents short circuits between primary and secondary sides.

Make sure that the output voltage of the power supply does not exceed 32 V even in the event of an error.

Insulation rating

When selecting the operating equipment, please take into consideration the contamination and surge voltages, which may occur during operation.

The IB IL 24 LPSDO 8 V2-PAC module is designed for surge voltage category II (according to DIN EN 60664-1). If you expect surge voltages in the system, which exceed the values defined in surge voltage category II, take into consideration additional measures for voltage limitation.

Installation and configuration

Please observe the instructions for installing and configuring the system (see "Documentation" on page 1-6).



WARNING: Depending on the application, incorrect installation and upgrades can pose serious risks for the user

The user is obliged to design the devices used and their installation in the system according to these requirements. This also means that existing plants and systems retrofitted with the SafetyBridge system must be checked and tested again in this respect.

1.3 Safety of the machine or system

The machine/system manufacturer and the operator are solely responsible for the safety of the machine or system and the implemented application, in which the machine or system is used. The Machinery Directive must be observed.

Draw up and implement a safety concept

In order to use the safety module described in this document, you must have drawn up an appropriate safety concept for your machine or system. This includes a hazard and risk analysis according to the directives and standards specified in "Directives and standards" on page 1-5, as well as a test report (checklist) for validating the safety function (see "Appendix: Checklists" on page B-1).

The target safety integrity level (SIL according to EN 61508, SIL CL according to EN 62061 or performance level and category according to EN ISO 13849-1) is ascertained on the basis of the risk analysis. The safety integrity level ascertained determines how to connect and parameterize the safety module within the overall safety function.

Within a SafetyBridge system, the IB IL 24 LPSDO 8 V2-PAC safety module can be used to achieve safety functions with the following requirements depending on the conditions of use:

- Up to SIL 3 according to standard EN 61508
- Up to SIL CL 3 according to standard EN 62061
- Up to Cat. 4/PL e according to standard EN ISO 13849-1



Please also refer to "Achievable safety depending on the modules used" on page A-30.

Check hardware and parameterization

Carry out a **validation** every time you make a safety-related modification to your overall system.

Use your test report to ensure that:

- The safe devices are connected to the correct safe sensors and actuators
- The safe input and output devices have been parameterized correctly
- The safety functions have been wired correctly

1.4 Safety for starting applications

Consider your machine or system when determining the start conditions:

- Starting the machine or system may only take place when no persons are within the danger zone.
- Comply with the requirements of EN ISO 13849-1 with respect to manual resetting functions.

This applies to:

- Switching on of safe devices.
- Acknowledgment of device error messages.
- Acknowledgment of communication errors.
- Acknowledgment of block error messages in the application.
- Removing safeguards for safety functions.

Observe your safety logic during programming/configuring:

- The change from a safe state (replacement value = 0) to the operating state can cause an edge change (zero-one-edge).
- Include measures in your safety logic that prevent this edge from starting or restarting of the machine/system unexpectedly.

1.5 Directives and standards

The manufacturers and operators of machines and systems, in which the IB IL 24 LPSDO 8 V2-PAC module is used, are responsible for adhering to all applicable directives and legislation.

For the standards observed by the module, please refer to the certificate issued by the approval body and the EC declaration of conformity. These documents are available on the Internet at www.phoenixcontact.net/catalog.

1.6 Correct usage

Only use the SafetyBridge system in accordance with the instructions in this section.

The IB IL 24 LPSDO 8 V2-PAC safety module is designed exclusively for use in a SafetyBridge system.

It can only perform its safety-related tasks within the system if it has been integrated into the execution process correctly and in such a way as to avoid errors.

You must observe all information in this manual as well as in the documents listed in "Documentation" on page 1-6. In particular, only use the module according to the technical data and ambient conditions specified in Section 10, "Technical data and ordering data" on page 10-1 and onwards.

Within a SafetyBridge system, the safety module can be used to achieve safety functions with the following requirements depending on the conditions of use:

- Up to SIL 3 according to standard EN 61508
- Up to SIL CL 3 according to standard EN 62061
- Up to Cat. 4/PL e according to standard EN ISO 13849-1



Please also refer to "Achievable safety depending on the modules used" on page A-30.

The safety module is designed for connecting single-channel or two-channel actuators, which can be used in association with safety technology.

For example, the module can be used in the following applications:

- Safety circuits according to EN 60204 Part 1
- Safe shutdown of contactors, motors (24 V DC), valves, ohmic, inductive, and capacitive loads

The module is **not** suitable for applications in which stop category 1 also has to be observed in the event of an error (see also "Behavior of the outputs in the event of enabled switch-off delay for stop category 1" on page 5-4).

1.7 Documentation

Latest documentation

Make sure you always use the latest documentation. Changes or additions to this document can be found on the Internet at www.phoenixcontact.com/catalog.

SafetyBridge system

When working on the SafetyBridge system and its components, you must always keep this user manual and other items of product documentation to hand and observe the information therein.

User manuals:

- For the controller used
- For SafetyBridge system I/O modules
- For SafetyBridge system function blocks

Please also observe the relevant information about the bus system used.

Inline product range

IL SYS INST UM E

Automation terminals of the Inline product range (configuration and installation)

Documentation for the bus coupler used

1.8 Abbreviations used

Table 1-1 Abbreviations used

Abbreviation	Meaning	Standard	Example
SIL	Safety integrity level	EN 61508	SIL 2, SIL 3
SIL CL	SIL claim limit	EN 62061	SIL CL 3
Cat.	Category	EN ISO 13849-1	Cat. 2, Cat. 4
PL	Performance level	EN ISO 13849-1	PL e, PL d

Table 1-2 Abbreviations used

Abbreviation	Meaning
PELV	Protective extra-low voltage A circuit in which the voltage does not exceed 30 V AC, 42.4 V peak value or 60 V DC under normal conditions or single-fault conditions, except in the event of grounding errors in other circuits. A PELV circuit is like a SELV circuit, but is connected to protective earth ground. (According to EN 61131-2)
EUC	Equipment under control

1.9 Safety hotline

Should you have any technical questions, please contact our 24-hour hotline.

Phone: +49 5281 9462777

E-mail: safety-service@phoenixcontact.com

2 Product description

2.1 Note about the system description

The SafetyBridge system is described in "Appendix: SafetyBridge system" on page A-1.

In the description of the IB IL 24 LPSDO 8 V2-PAC safety module, it is assumed that you are familiar with the SafetyBridge system. If this is not the case, please refer to "Appendix: SafetyBridge system" on page A-1 first for information about the system.

2.2 Brief description of the safety module

The IB IL 24 LPSDO 8 V2-PAC module is designed for use within an Inline station. The module features integrated configurable safety logic and safe digital outputs.

The IB IL 24 LPSDO 8 V2-PAC safety module can be used as part of an Inline station at any point within a SafetyBridge system.

The transmission speed of the Inline local bus can be set to 500 kbaud or 2 Mbaud on the safety module using switches.

Use the same transmission speed throughout an Inline station.

The module has a 10-pos. DIP switch, which is used to set the island number and operating mode.

The module has four safe positive switching digital outputs for two-channel assignment or eight safe positive switching digital outputs for single-channel assignment.

The outputs can be parameterized according to the application. The outputs enable actuators to be integrated into the SafetyBridge system.

Within a SafetyBridge system, the IB IL 24 LPSDO 8 V2-PAC safety module can be used to achieve safety functions with the following requirements:

- Up to SIL 3 according to standard EN 61508
- Up to SIL CL 3 according to standard EN 62061
- Up to Cat. 4/PL e according to standard EN ISO 13849-1



Please also refer to "Achievable safety depending on the modules used" on page A-30.

2.3 Structure of the safety module

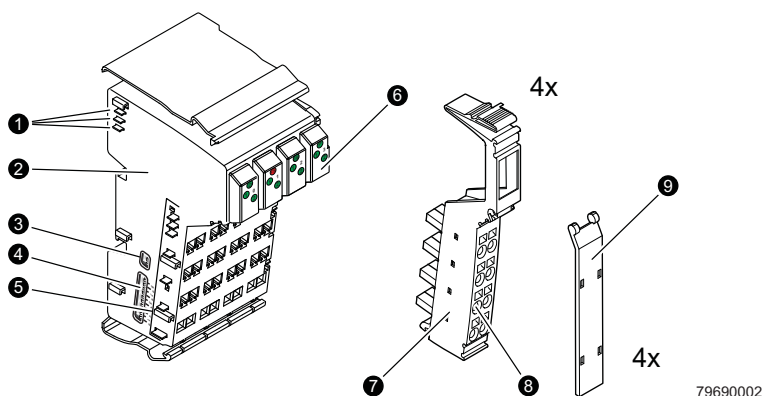

Figure 2-1 Structure of the safety module

- 1 Data jumpers (local bus)
- 2 Electronics base with labeling including version designation hardware/firmware/firmware (not shown)
- 3 Switch for setting the transmission speed and operating mode
- 4 Switch for setting the address
- 5 Potential jumper
- 6 Diagnostic and status indicators; for assignment and meaning see "Local diagnostic and status indicators" on page 2-6
- 7 Inline connector; for assignment see "Terminal point assignment" on page 3-4
- 8 Terminal points
- 9 Labeling field

2.4 Housing dimensions

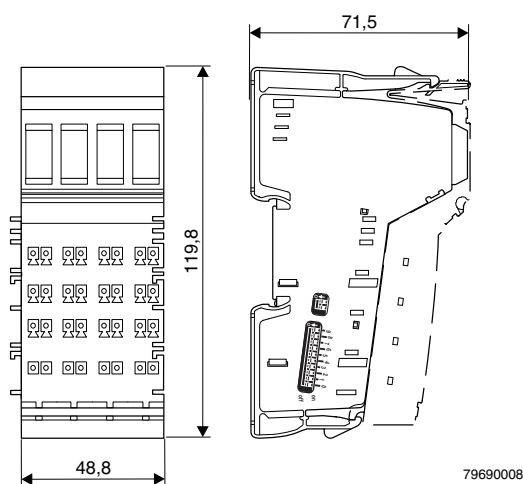

Figure 2-2 Housing dimensions (in mm)

2.5 Safe digital outputs

The safety module has safe positive switching digital outputs, which can be used as follows:

- For two-channel assignment:
 - Four two-channel outputs
- For single-channel assignment:
 - Eight single-channel outputs

Technical data

For the technical data for the safe outputs, please refer to page 10-4.

Parameterization

The individual safe digital outputs of a safety module can be parameterized differently. This means that the outputs can be adapted to various operating conditions and different safety integrity levels (SIL, SIL CL, Cat., PL) can be implemented.

In order to achieve a high level of error detection, the test pulses must be enabled. If this is not possible for the connected loads, the test pulses can be disabled. However, in this case error detection is reduced.



The safety integrity level (SIL, SIL CL, Cat., PL) and error detection that can be achieved depend on the parameterization, the structure of the actuator, and the cable installation (see "Connection examples for safe outputs" on page 6-1).

For information about parameterization, please refer to "Parameterization of the safe outputs" on page 5-2.

Diagnostics

Diagnostics are provided via both the local diagnostic indicators and the diagnostic messages, which are transmitted to the controller.

For information about the diagnostic messages of the outputs, please refer to "Safe digital output errors" on page 8-4.



CAUTION: Diagnostic data is not safety-related

The diagnostic data is not safety-related. This data must not be used to execute safety-related functions or actions.

IB IL 24 LPSDO 8 V2-PAC

Requirements for controlled devices/actuators

The error detection of the module varies depending on the parameterization. This results in specific requirements for the actuators.

- If the outputs are parameterized with test pulses, the output circuits are tested by test pulses at regular intervals. These test pulses are visible at the output and can trigger undesirable reactions with quick responding actuators.



WARNING: Unintentional machine startup

If the process does not tolerate this behavior, actuators with sufficient inertia must be used.

In general, the load must not be so dynamic that it causes dangerous states within 1 ms.

Quick actuators, which offer a safety-related response to pulses in under 1 ms, may **not generally** be used.

Switching off the test pulses affects the error detection of the module. Please observe the achievable safety integrity level, which is specified in "Connection examples for safe outputs" on page 6-1.

The failure detection time is 20 ms.



Please refer to "Single-channel assignment of safe outputs" on page 6-5 and "Two-channel assignment of safe outputs" on page 6-8 for additional information.

- Only use appropriately qualified actuators.
- Use reliable components. These include, for example:
 - Control contactors according to EN 60947-4-1
 - Power contactors
 - Relays with positively driven contacts according to DIN EN 50205
- Use relays or contactors with positively driven N/C contacts to safely monitor the state (pick-up, drop-out).
- Please observe any special environmental requirements in your application when selecting the controlled devices.
- Please note applicable C standards in your application (e.g., EN 1010), in which, for example, the number of controlled devices required to achieve a particular category is specified.

2.6 Connection options for actuators depending on the parameterization

Actuators that meet various safety requirements depending on the parameterization can be connected to the outputs. For connection examples, please refer to Section 6, "Connection examples for safe outputs".

The maximum achievable SIL/SIL CL/Cat./PL is specified in the table.

In order to achieve this:

- Observe the information in the connection examples (see Section 6, "Connection examples for safe outputs")
- Observe the requirements of the standards with regard to the external wiring and the actuators to be used to achieve a SIL/SIL CL/Cat./PL (see "Measures required to achieve a specific safety integrity level" on page 6-3)

"Output" parameterization	Output OUT0 to OUT3	
	Single-channel	Two-channel
Test pulses	Any	ON/OFF*
Achievable category	SIL 2/SIL CL 2/Cat. 3/PL d	SIL 3/SIL CL 3/Cat. 4/PL e
For connection example, see page	6-5	6-8

Key:

- * If the test pulses are disabled, a cross circuit between the outputs is only detected if the output is enabled.



To achieve Cat. 3, two-channel actuators are usually used.

2.7 Local diagnostic and status indicators

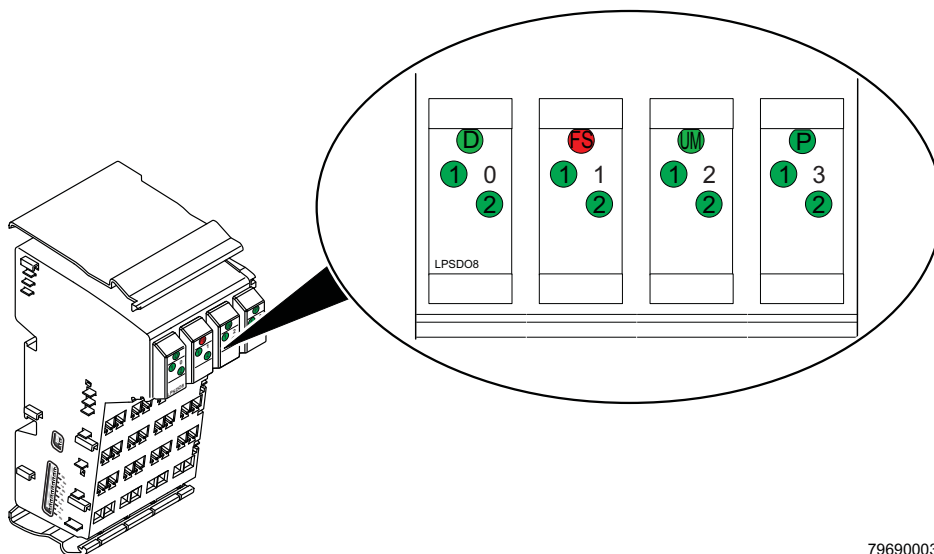



Figure 2-3 Local diagnostic and status indicators of the IB IL 24 LPSDO 8 V2-PAC module

79690003

Table 2-1 Local diagnostic and status indicators

D	Green LED	Diagnostics
	OFF:	Communications power is not present
	Flashing at 0.5 Hz:	Communications power present, local bus not active
	Flashing at 4 Hz:	Communications power present, error at the interface between previous and flashing terminal (the terminals after the flashing terminal cannot be addressed). (E.g., loose contact at the bus interface, terminal before the flashing terminal has failed, another terminal was snapped on during operation (not permitted))
	<div style="border: 1px solid black; padding: 5px;"> <p>i Observe the module startup time of approximately 16 s. During this time the D LED flashes at 4 Hz and the bus cannot be started up. Do not start to download the configuration and parameter data record until the firmware has started up (approx. 16 s; bit SA = 1 in Dev-Reg-LPSDO; see Appendix A 5.2 on page A-17).</p> </div>	
ON:	Communications power present, local bus active	
FS	Red LED	Failure state
	Flashing at 1 Hz:	Device not parameterized or parameterization was not accepted
	ON:	Hardware fault The output drivers are reset, there is no communication to the satellites Or: Impermissible switch position The module will respond to certain impermissible switch positions by entering the failure state immediately after power up.

Table 2-1 Local diagnostic and status indicators (continued)

UM	Green LED	Monitoring the supply voltage U_M
	OFF:	Communications power is not present
	Flashing at 1 Hz:	U_M below the permissible voltage range (undervoltage)
	ON:	U_M present
P	Green LED	Status indicator for communication
	OFF:	IB IL 24 LPSDO 8 V2-PAC not parameterized
	Flashing at 0.5 Hz:	IB IL 24 LPSDO 8 V2-PAC is parameterized, but safe communication is not running to at least one satellite
	ON:	Communication OK IB IL 24 LPSDO 8 V2-PAC is parameterized and safe communication is running without any errors to all configured satellites. If no satellites have been configured: IB IL 24 LPSDO 8 V2-PAC is parameterized. Corresponds to COK bit = 1 (see "Dev-Diag-LPSDO (LPSDO diagnostics)" on page A-18)
OUT 0.1 - 3.2	Green/red LED	Status of each output (see "Terminal point assignment" on page 3-4)
	Green:	Output at logic 1
	OFF:	Output at logic 0, no error
	Red ON:	Short circuit/overload of an output (This diagnostic message is stored temporarily on the module. The message is stored in the volatile memory and will be lost after a voltage reset.)
		In the event of an error (red LED ON), the output is switched off until the acknowledgment sent by the controller is received by the safety module (see also "Safe digital output errors" on page 8-4).

2.8 Safe state

The safe state for the module is the low state at the output terminals (see "Safe digital outputs" on page 2-3).

The safe state can be entered in the following cases:

1. Operating state
2. Error detection in I/O devices
3. Device errors
4. Parameterization errors

2.8.1 Operating state

In the operating state, the outputs can enter states "1" or "0". In general, state "0" is the safe state.



WARNING: Loss of the safety function possible due to undetected accumulation of errors

Also evaluate the diagnostics of modules that are not used, but are connected to the power supply, at regular intervals or disconnect these modules from the supply voltage.

2.8.2 Error detection in I/O devices

Outputs

If an error is detected at an output, the affected output is disabled ("0" = OFF = safe state).

Depending on the parameterization, the following errors can be detected at outputs:

- Short circuit
- Cross circuit
- Overload

The relevant diagnostic message is transmitted to the controller (see "Safe digital output errors" on page 8-4). For information about which errors are detected and when, please refer to "Connection examples for safe outputs" on page 6-1.



If an error occurs on a channel of an output parameterized as "two-channel", the other corresponding channel also enters the safe state.

2.8.3 Device errors

Outputs

If a hardware fault in the internal circuit is detected at an output, **all** module outputs are disabled ("0" = OFF = safe state).

The relevant diagnostic message is transmitted to the controller (see "Safe digital output errors" on page 8-4).

Serious errors

All serious errors that can result in the loss of or adversely affect the safety function cause the entire module to enter the safe state. The FS LED on the safety module is permanently on.

The following errors result in the safe state:

- Serious hardware faults in the internal circuit
- User errors
- Module overload
- Module overheating
- Faulty supply voltage
- Impermissible switch position, DIP switches

The relevant diagnostic message is transmitted to the controller (see "Errors: Messages and removal" on page 8-1).



WARNING: Loss of the safety function due to sequential errors

In the event of a device error, the following measures should be taken to prevent sequential errors:

Disconnect the module from the power supply and replace it.

2.8.4 Parameterization errors

Parameterization errors are indicated:

- As long as the module is not parameterized
- or
- In the event of faulty parameterization

Parameterization errors cause the entire module to enter the safe state. The FS LED on the safety module flashes.

In the event of faulty parameterization, the relevant diagnostic message is transmitted to the controller (see "Parameterization errors" on page 8-6).



Exception:

If an output is operated in stop category 1 and this output is within the switch-off delay time, then another instance of faulty parameterization results in the entire module switching to the safe state only once the switch-off delay time has elapsed.

2.9 Process data words

The module uses 8, 16, or 24 words in the Inline system. How these words are mapped is described in "Process image" on page A-13.

The input data only indicates the actual status of the outputs if no bus errors or device errors are present. Even during the parameterized switch-off delay in stop category 1, the status of the outputs on the module does not correspond to the status of the outputs on the controller.

The parameterization of the outputs determines whether the input data is mapped in single-channel or two-channel mode. The value for "parameterized output" for the outputs is also set for the input data.

2.10 Programming data/configuration data

2.10.1 Local bus

Operating mode	SafetyBridge 24 words	SafetyBridge 16 words	SafetyBridge multiplexer
ID code	AB _{hex} (171 _{dec})	AB _{hex} (171 _{dec})	AB _{hex} (171 _{dec})
Length code	18 _{hex} (24 _{dec})	10 _{hex} (16 _{dec})	08 _{hex} (08 _{dec})
Input address area	Application-specific	Application-specific	Application-specific
Output address area	Application-specific	Application-specific	Application-specific
Parameter channel (PCP)	0 words	0 words	0 words
Register length	24 words	16 words	8 words

2.10.2 Other bus systems or networks



The programming data/configuration data is defined in the device description (FDCML, GSD, GSDML, etc.) according to the bus or network used.

3 Inline potential and data routing, and Inline connectors

3.1 Inline potential and data routing

For operation, the safety module must be integrated in a Inline station within the Safety-Bridge system.

The bus signals are transmitted via the Inline data jumpers. The required supply voltages are transmitted via the Inline potential jumpers.



For more detailed information about potential and data routing within an Inline station, please refer to the IL SYS INST UM E user manual.

The segment circuit is looped through the safety module and is available again after the module. The segment circuit cannot be accessed in the safety module.

3.2 Supply voltage U_L

Feed in the 24 V supply voltage U_{BK}/U_{24V} at a bus coupler or a suitable power terminal (IB IL 24 PWR IN/R). The 7.5 V voltage U_L is generated from this 24 V supply voltage in the bus coupler or power terminal. It is made available to the safety module via the Inline potential jumper U_L .



WARNING: Loss of the safety function when using unsuitable power supplies

For the voltage supply at the bus coupler or power terminal, please note:
Only power supplies according to EN 50178/VDE 0160 (PELV) may be used.
Please also observe the points in "Electrical safety" on page 1-3.

The supply voltage U_L is used to supply the bus controller board and the communications power. For technical data for the supply voltage U_L , please refer to "Supply voltage U_L (logic)" on page 10-3.

The maximum current carrying capacity for the supply voltage U_L is 2 A.

This current carrying capacity can be reduced if certain terminals are used. Please refer to the information in the terminal-specific data sheets.

3.3 Supply voltage U_M

Feed in the supply voltage at a bus coupler or a power terminal. It is made available to the safety module via the Inline potential jumper U_M .



WARNING: Loss of the safety function when using unsuitable power supplies

For the voltage supply at the bus coupler or power terminal, please note:
Only power supplies according to EN 50178/VDE 0160 (PELV) may be used.
Please also observe the points in "Electrical safety" on page 1-3.

The supply voltage U_M is used to supply the output circuits. For technical data for the supply voltage U_M , please refer to "Supply voltage U_M (actuators)" on page 10-3.

The maximum current carrying capacity for the main circuit U_M is 8 A (total current with the segment circuit that is not used in the safety terminal). This current carrying capacity can be reduced if certain terminals are used. Please refer to the information in the terminal-specific data sheets.

If the limit value of the potential jumpers U_M and U_S is reached (total current of U_S and U_M), a new power terminal must be used.



NOTE: Module damage due to polarity reversal

Polarity reversal places a burden on the electronics and, despite protection against polarity reversal, can damage the module. Therefore, polarity reversal must be prevented.

For the behavior of the safety module in the event of an error at the supply voltage, please refer to "Supply voltage errors" on page 8-5.

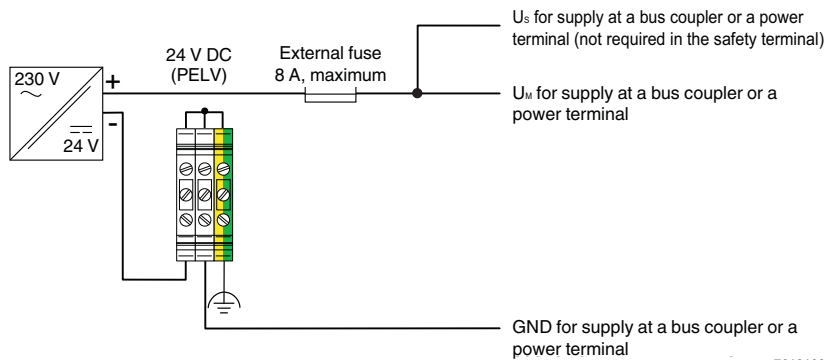

Figure 3-1 Supply U_M with connection to functional earth ground according to 60204-1



WARNING: Loss of functional safety due to parasitic voltages

Feed in the supply voltages U_M and U_S at a bus coupler and/or a power terminal from the same power supply unit, so that the loads of IB IL 24 LPSDO 8 V2-PAC are not affected by parasitic voltages in the event of an error.

**NOTE: Damage to module electronics in the event of surge voltage**

Do not use a DC distribution network.

DC distribution network according to IEC 61326-3-1:

A DC distribution network is a DC power supply network, which supplies a complete industrial hall with DC voltage and to which any device can be connected. A typical system or machine distribution is not a DC distribution network. For devices that are provided for a typical system or machine distribution, the DC connections are viewed and tested as I/O signals according to IEC 61326-3-1.

3.4 Terminal point assignment

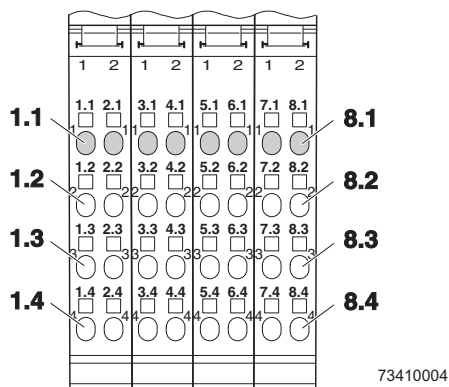

Figure 3-2 Terminal point assignment

The Inline connectors are supplied with the module. They are keyed and labeled accordingly for connection to prevent polarity reversal. If other connectors are used according to the ordering data, they must also be keyed.



Only use the connectors supplied with the module or connectors that are approved as replacement items (see "Ordering data: Accessories" on page 10-7).

The following applies for the tables below:

- All outputs are safe digital outputs
- 0 V (GND): Common ground for outputs
- FE: Common functional earth ground

Table 3-1 Terminal point assignment for connector 1

Terminal point	Signal	Channel assignment	LED
1.1	OUT0_Ch1	Output 0, channel 1	0.1
2.1	OUT0_Ch2	Output 0, channel 2	0.2
1.2	Not used		
2.2	Not used		
1.3	0 V (GND)	Channel 1 and channel 2	
2.3	0 V (GND)	Channel 1 and channel 2	
1.4	FE		
2.4	FE		

Inline potential and data routing, and Inline connectors

Table 3-2 Terminal point assignment for connector 2

Terminal point	Signal	Channel assignment	LED
3.1	OUT1_Ch1	Output 1, channel 1	1.1
4.1	OUT1_Ch2	Output 1, channel 2	1.2
3.2	Not used		
4.2	Not used		
3.3	0 V (GND)	Channel 1 and channel 2	
4.3	0 V (GND)	Channel 1 and channel 2	
3.4	FE		
4.4	FE		

Table 3-3 Terminal point assignment for connector 3

Terminal point	Signal	Channel assignment	LED
5.1	OUT2_Ch1	Output 2, channel 1	2.1
6.1	OUT2_Ch2	Output 2, channel 2	2.2
5.2	Not used		
6.2	Not used		
5.3	0 V (GND)	Channel 1 and channel 2	
6.3	0 V (GND)	Channel 1 and channel 2	
5.4	FE		
6.4	FE		

Table 3-4 Terminal point assignment for connector 4

Terminal point	Signal	Channel assignment	LED
7.1	OUT3_Ch1	Output 3, channel 1	3.1
8.1	OUT3_Ch2	Output 3, channel 2	3.2
7.2	Not used		
8.2	Not used		
7.3	0 V (GND)	Channel 1 and channel 2	
8.3	0 V (GND)	Channel 1 and channel 2	
7.4	FE		
8.4	FE		



WARNING: Loss of functional safety due to parasitic voltages

Connect the ground of the actuator to the ground terminal point of the corresponding output on the Inline connector. An external ground may not be used.

4 Assembly, removal, and electrical installation

4.1 Assembly and removal

4.1.1 Unpacking the module

The module is supplied in an ESD box together with a package slip with installation instructions. Please read the complete package slip carefully.

The module may only be installed and removed by qualified personnel.

**NOTE: Electrostatic discharge**

The safety module contains components that can be damaged or destroyed by electrostatic discharge. When handling the safety module, observe the necessary safety precautions against electrostatic discharge (ESD) according to EN 61340-5-1 and EN 61340-5-2.

4.1.2 General

**WARNING: Unintentional machine startup**

Do not assemble or remove the module while the power is connected.

Before assembling or removing the module, disconnect the power to the module and the entire Inline station and ensure that it cannot be switched on again.

Make sure the entire station is reassembled before switching the power back on.

Observe the diagnostic indicators and any diagnostic messages.

The system may only be started provided neither the station nor the system poses a hazard.

The IB IL 24 LPSDO 8 V2-PAC safety terminal is designed for use within an Inline station. Only use the safety terminal in the 24 V DC area of an Inline station.

To ensure reliable operation, install the safety terminal in housing protected from dust and humidity (IP54 or higher). In order to prevent manipulation, secure the housing (control cabinet/control box) against being opened by unauthorized persons.

Mount all Inline terminals on 35 mm DIN rails.

Only connect the cables using the supplied Inline connectors or Inline connectors listed in the ordering data.

4.1.3 Setting the DIP switches



Set the DIP switches accordingly for your application **before** assembling the module in an Inline station. The switches cannot be accessed when the safety terminal is installed in the Inline station.

The module has a 2-pos. and a 10-pos. DIP switch.

The DIP switches are located on the left-hand side of the safety module.

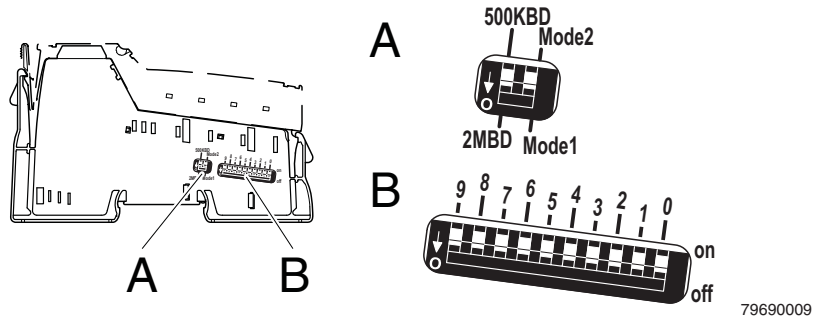

Figure 4-1 DIP switches

- A Switch for setting the transmission speed and the mode
- B Switch for setting the operating mode and the address

2-pos. DIP switch:

The transmission speed and the mode are set via the 2-pos. DIP switch.

**Left switch:
Transmission speed**

Set the transmission speed:

- 500 kbaud or
- 2 Mbaud

The transmission speed has been preset to 2 Mbaud.



Only use devices with a uniform transmission speed within an Inline station (a local bus). It is not possible to operate a mixture of devices with different transmission speeds.

**Right switch:
Mode**

Select SafetyBridge: mode

Table 4-1 SafetyBridge operating mode

Mode	Operating mode
1	SafetyBridge 16 words
2	SafetyBridge 24 words



As soon as more than three satellites are connected to one IB IL 24 LPSDO 8 V2-PAC, a data width of 24 words is required. In this case, set Mode 2.



The Mode switch is not relevant in SafetyBridge multiplexer mode.

Assembly, removal, and electrical installation

10-pos. DIP switch: Address



The operating mode and the island number are set via the 10-pos. DIP switch.

NOTE: Malfunction in the event of incorrect addressing

Make sure that in an overall system comprising the SafetyBridge system and any higher-level PROFIsafe system, the addresses (address within the SafetyBridge system and F-Address of the PROFIsafe system) are unique. Duplicate address assignment is not permitted.

Use switch 9 of the DIP switch to set the operating mode:

- 0 (off): SafetyBridge 16 or 24 words or
- 1 (on): SafetyBridge multiplexer.
In SafetyBridge multiplexer mode, the data width is 8 words.

Set switch 8 and switches 2 to 0 of the DIP switch to 0 (off).

Use switches 7 to 3 to set the island number.

An "island" always comprises the IB IL 24 LPSDO 8 V2-PAC and the satellites assigned to it.

The DIP switch is set to 3FF_{hex} by default. This address is not valid for a SafetyBridge system; therefore, a valid address must be set.



NOTE: Malfunction during mixed operation

During simultaneous use of SafetyBridge V2 and SafetyBridge V3 on a controller, make sure that the island number of the SafetyBridge V3 system is ≥ 8 .

This should be checked during overall validation of the system.

Use switches 9 to 5 to set the island number.

An "island" always consists of the IB IL 24 LPSDO 8 V3-PAC and the satellites assigned to it.

Overview of the switch positions

Table 4-2 Switch position for SafetyBridge V3

SafetyBridge V3									
Address switch									
Island number					Reserved				
9	8	7	6	5	4	3	2	1	0
					OFF	OFF	OFF	OFF	OFF
1_{dec} to 31_{dec}					0_{dec}				

Table 4-3 Switch position for SafetyBridge 16 words

SafetyBridge 16 words										
Mode switch	Address switch									
	Island number							Reserved		
	9	8	7	6	5	4	3	2	1	0
Mode 1	off	off						off	off	off
	1_{dec} to 31_{dec}							0_{dec}		

IB IL 24 LPSDO 8 V2-PAC

Table 4-4 Switch position for SafetyBridge 24 words

SafetyBridge 24 words										
Mode switch	Address switch									
	Island number							Reserved		
	9	8	7	6	5	4	3	2	1	0
Mode 2	off	off						off	off	off
			1 _{dec} to 31 _{dec}				0 _{dec}			

Table 4-5 Switch position for SafetyBridge multiplexer

SafetyBridge multiplexer										
Mode switch	Address switch									
	Island number							Reserved		
	9	8	7	6	5	4	3	2	1	0
Any	on	off						off	off	off
			1 _{dec} to 31 _{dec}				0 _{dec}			

4.1.4 Assembly and removal of the safety module



For general information about assembling and removing Inline terminals, please refer to the IL SYS INST UM E user manual.

Assembly



- Set the DIP switches prior to assembly (see "Setting the DIP switches" on page 4-2). The DIP switches cannot be accessed when the safety module is installed in the In-line station.
- Observe a mounting distance of 30 mm above and 40 mm below the safety module. Shorter distances may inhibit proper handling during installation.

– Snap on base

- Disconnect the power to the station.
- Before snapping on the safety module, remove the inserted connectors from the safety terminal and the adjacent connector from the neighboring Inline terminal on the left. This prevents the potential routing knife contacts and the keyway/featherkey connections from being damaged.
- Hold the safety module perpendicular and snap it onto the DIN rail (7.5 mm in height).



Ensure that **all** featherkeys and keyways on adjacent terminals are **securely** interlocked.

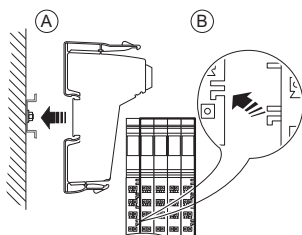

Figure 4-2 Snapping on the safety module base

- Check that all the snap-on mechanisms are securely snapped into place.
- Insert the connectors in the specified order (A, B).

– Insert connectors



Only use the connectors supplied with the module or connectors that are approved as replacement items (see "Ordering data: Accessories" on page 10-7).

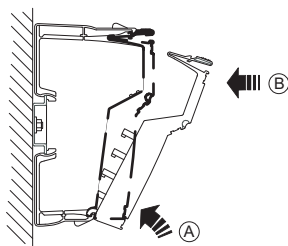

Figure 4-3 Inserting the connector

IB IL 24 LPSDO 8 V2-PAC**Removal**

- Disconnect the power to the station.
- Before snapping on the safety module, remove the connectors from the safety module and the adjacent connector from the neighboring Inline terminal on the left.

– Remove connectors

- Remove the connector by pressing the back shaft latching (A) and levering off the connector (B).

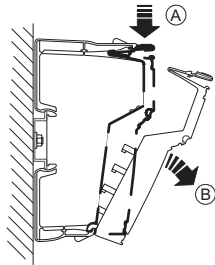

Figure 4-4 Removing the connector

– Remove base

- Release the base by pressing on the front and back snap-on mechanisms (A) and pull it out perpendicular to the DIN rail (B).

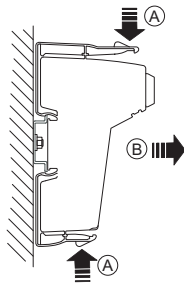

Figure 4-5 Removing the safety module base

4.2 Electrical installation



WARNING: Electric shock/unintentional machine startup

Prior to electrical installation, disconnect the power to the system and make sure that it cannot be switched on again unintentionally.

Make sure installation has been completed before switching the power back on.

The system may only be started provided the system does not pose a hazard.

4.2.1 Electrical installation of the Inline station

Electrical installation of the Inline station includes the following:

- Connecting the bus system to the Inline station
- Connecting the supply voltages for the Inline station

Carry out electrical installation for the Inline station according to the IL SYS INST UM E user manual or the Inline system manual for your bus system. Please also observe the specifications in the documentation for the bus coupler used.

4.2.2 Electrical installation of the safety module



During installation, always observe the instructions in "Electrical safety" on page 1-3.

Take measures to prevent the incorrect connection, polarity reversal, and manipulation of connections.

The supply voltages are supplied at a bus coupler and/or a power terminal and are supplied to the safety module via the potential jumpers. Therefore, the electrical installation of the safety module only involves connecting the actuators.

The actuators are connected via Inline connectors.

- Wire the connectors according to your application. For the terminal point assignment, please refer to "Terminal point assignment" on page 3-4.

For wiring, proceed as follows:

- Strip 8 mm off the cable.



Inline wiring is normally done without ferrules. However, it is possible to use ferrules. If using ferrules, make sure they are properly crimped.

- Push a screwdriver into the slot of the appropriate terminal point (Figure 4-6, detail 1), so that you can insert the wire into the spring opening. Phoenix Contact recommends the SZF 1 - 0.6X3.5 screwdriver (Order No. 1204517; see Phoenix Contact "CLIPLINE" catalog).
- Insert the wire (Figure 4-6, detail 2). Remove the screwdriver from the opening. This clamps the wire.

IB IL 24 LPSDO 8 V2-PAC

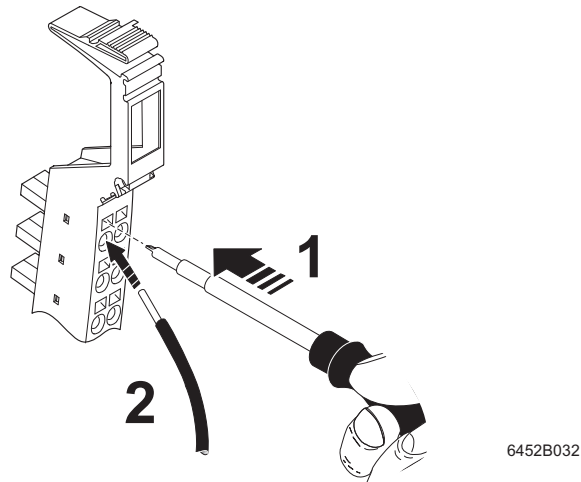

Figure 4-6 Connecting unshielded cables

- Insert the assembled connectors in the corresponding module slot (see "Terminal point assignment" on page 3-4).
- Label all connections to prevent connections to the Inline connectors being mixed up (see IL SYS INST UM E user manual).

5 Parameterization of the safety module

5.1 Parameterization of the safety module in a Safety-Bridge system



For information about the configuration and parameterization of the SafetyBridge system, please refer to "Configuration and parameterization using the SAFECONF tool" on page A-26.

Parameterization includes the following:

- Assignment of island numbers
- Parameterization of outputs

Configuration includes the following:

- Creation of the logic function with SAFECONF

Island number

The island number is a unique address of a SafetyBridge island. Set the same island number both in SAFECONF and on the module.



For additional information about the island number, please refer to "Operating modes and setting the DIP switches in the SafetyBridge system" on page A-10 and "SafetyBridge address assignment" on page A-6.

Set this address via the DIP switches prior to assembling the safety module (see "Setting the DIP switches" on page 4-2).

Parameterization and configuration of the module

Parameterization and configuration determine the behavior of the module and thus have a considerable effect on the safety integrity level that can be achieved.

To parameterize and configure the module, the parameterization and configuration created in the parameterization tool must be written from the controller to the module (e.g., with a function block).



For information about downloading, please refer to "Downloading the configuration and parameter data record following power up" on page A-27.

The supply voltage must be present and the local bus must be in the RUN state when downloading.

The module cannot be operated if it is not parameterized. In this case, the FS LED flashes.

The module is ready to operate if the parameters for all outputs are valid and transmitted without errors. Valid output data is only written in this state. In any other state, every output is set to the safe state.

If errors are detected during parameterization, the parameter data is not transmitted. The FS LED on the module flashes to indicate that the parameterization is invalid. The error is also indicated at the controller. In this case, check and correct the settings.

5.2 Parameterization of the safe outputs

The individual outputs of a safety module can be parameterized differently and thus achieve different safety integrity levels (SIL, SIL CL, Cat., PL).

Two-channel

If the outputs are operated via two channels, the following fixed assignment applies:

- OUT0_Ch1 to OUT0_Ch2
- OUT1_Ch1 to OUT1_Ch2
- OUT2_Ch1 to OUT2_Ch2
- OUT3_Ch1 to OUT3_Ch2

Single-channel

If two-channel operation in the external wiring of the outputs is not required, the outputs can be parameterized in such a way that they operate independently of one another (single-channel).

Parameterization

All safe outputs must be parameterized individually. The parameterization options are described in Table 5-1.

Table 5-1 Parameterization of outputs

Parameterization	Value range	Remark
	OUT0 - OUT3	
Assignment	Not assigned Assigned	The outputs that are not assigned are disabled. However, the monitoring of these outputs remains active.
Output	Single-channel Two-channel	In two-channel operation, the assignment of the outputs to one another is specified and cannot be parameterized.
Switch-off delay for stop category 1	Disabled Enabled	Disabled (default): No switch-off delay. Enabled: The outputs are switched off once the parameterized switch-off delay has elapsed. Please observe the notes below this table.
Switch-off delay for stop category 1	1 to 63	Time conversion according to the parameterization of the "Value range of switch-off delay for stop category 1" parameter. Permissible value range: OUT0 to OUT3: 150 ms to 630 s Accuracy: -5% of the parameterized value - 2 ms/+0 ms Please observe the notes below this table.

Parameterization of the safety module

Table 5-1 Parameterization of outputs (continued)

Parameterization	Value range	Remark
	OUT0 - OUT3	
Value range of switch-off delay for stop category 1	Value x 10 in ms Value x 100 in ms Value in s Value x 10 in s	Value range/unit for the parameterization of the "Switch-off delay for stop category 1" parameter. Please observe the notes below this table.
Test pulses (output disabled) (in software: test impulses (output switched off))	Disabled Enabled	Enabling and disabling of test pulses. For these test pulses, the output drivers that are disabled are temporarily enabled for test purposes. See note below this table.
Enable	Disabled Enabled	Disabled (default value): The corresponding safe output is operated exclusively according to the safety logic. Enabled: Enable is active; the safe output data is output after being ANDed with the "Data_LPSDO" process data item (Data_LPSDO see Figure A-4 on page A-15) See also "Enable principle" on page A-22.

Test pulses

**Note on test pulses**

If the test pulses are disabled, cross circuits and short circuits cannot be detected. Regardless of the parameterization selected under "Test impulses (output switched off)", the outputs parameterized as "Not assigned" are tested by test pulses. Please also refer to "Requirements for controlled devices/actuators" on page 2-4 and "Connection examples for safe outputs" on page 6-1.

Switch-off delay for stop category 1

The **switch-off delay for stop category 1** is calculated from the "Switch-off delay for stop category 1" and "Value range of switch-off delay for stop category 1" parameters.

Switch-off delay for stop category 1 =
Switch-off delay for stop category 1 x
Value range of switch-off delay for stop category 1



If the switch-off delay for stop category 1 is parameterized with a value less than 150 ms, this value is rejected as a parameterization error (error code 028x_{hex}).

Two-channel parameterization

Please note the following for two-channel parameterization:

Ensure that the values for the switch-off delay for stop category 1 are the same for both channels. This means that the time must have the same value and the same value range.

5.3 Behavior of the outputs in the event of enabled switch-off delay for stop category 1

Depending on the event that causes the outputs to be switched off, and on the parameterization of the switch-off delay, the time until the outputs are actually switched off can vary.

Table 5-2 Switching off of the outputs according to the trigger event and the parameterization

Switching off of outputs	Influence of parameterized switch-off delay	Switching off of outputs
– By the controller	Yes	Once the parameterized switch-off delay has elapsed
– After a bus error	Yes	Once the parameterized switch-off delay has elapsed
– After a short circuit, cross circuit, failure of the supply voltage, or hardware fault	No	Immediately (only stop category 0)
– After time monitoring has been exceeded (watchdog time; F_{WD_Time}) (e.g., in the event of faulty bus connection)	Yes	Once the parameterized switch-off delay has elapsed



WARNING: Delayed shutdown when using stop category 1

For stop category 1 please take into consideration the following:

- The guaranteed shutdown time t_G is extended by the parameterized switch-off delay.
- In the event of an error (excluding bus errors) the affected outputs are switched off immediately (without delay). In this case, only stop category 0 is supported.

For the switch-off operation, please take into consideration the following:

- The switch-off operation can be interrupted by switching the output on again.
- If the parameterization of the module is modified, the modified parameterization does not take effect until all the outputs have been switched off.
If the parameterization is modified before the switch-off operation is complete, diagnostic message 02F2_{hex} is generated.
- Carry out a validation every time the parameterization is modified.
- Please note that when the parameterization is modified, this can result in delayed startup due to the switch-off delay time.

6 Connection examples for safe outputs

6.1 Explanation of the examples

Depending on the type of wiring, the outputs of a module can achieve different safety integrity levels (SIL, SIL CL, Cat., PL) at the same time (as long as the settings do not contradict one another).

The following examples only describe the options for the electrical connection of controlled devices/actuators to the safe outputs.

Should you have any questions regarding applications to be implemented, please contact the Phoenix Contact safety hotline (see "Safety hotline" on page 1-7).

The following are specified for each example:

- **Basic specifications**
The main data for the example is specified in the table.
- **Device diagnostics and behavior of the module in the event of an error**
Diagnostic capability depends on the parameterization.
If a message is transmitted to the controller in the event of an error, the message is specified in the tables. For information about the relevant error code, possible remedies, and information about whether acknowledgment is required, please refer to "Errors: Messages and removal" on page 8-1.
- **Typical parameterization**
The table illustrates an example of all the parameters for the specified assignment.

Key for all tables in this section:

Table 6-1 "Device diagnostics and behavior of the module in the event of an error" tables

Representation	Meaning
SF	Safety function
OUTx	OUT1 or OUT2 LED; diagnostic message for each output

Table 6-2 Parameterization tables

Representation	Meaning
Bold	Mandatory setting
Normal	Typical setting, another setting is possible depending on the application
–	Not evaluated

Errors (cross circuits, short circuits), which can be prevented by correct installation (e.g., protected cable installation, isolated cable installation, double insulation, use of ferrules) are not described in the following tables.

Therefore, for example, only errors between outputs, which are on the same connector, are described. For example, in the event of correct installation, cross circuits with outputs of other connectors cannot occur.



For all examples, please also observe the measures specified in the individual tables, which must be taken to achieve the specified SIL/SIL CL/Cat./PL and all measures according to standards EN 61508, EN 62061, EN 954-1, and EN ISO 13849-1 to achieve the specified SIL/SIL CL/Cat./PL.



WARNING: Disregarding this warning may lead to the loss of the safety function

An external voltage may not be supplied in an output (e.g., via cross circuits). These errors can adversely affect the operation of the module (or even destroy the module) and thus result in the loss of the safety function. Therefore, these errors must be prevented. Install the connecting cables for connecting the actuators so that they are protected against cross circuits.

Please observe the load capacity of the outputs according to the technical data in "Safe digital outputs" on page 2-3.

6.2 Notes on the protective circuit for external relays/contactors (free running circuit)

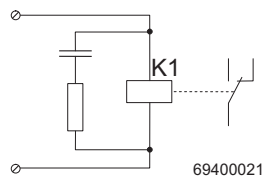

Figure 6-1 Example of the free running circuit for an external relay



- Limit the voltage induced on circuit interruption to < -15 V (e.g., with RC elements, suppressor diodes or varistors).
- Please note that the free running circuit affects the fall time and the service life of the contactor.
- Please observe the specifications of the relay manufacturer when sizing the relay protective circuit.

6.3 Measures required to achieve a specific safety integrity level

The safety integrity level (SIL, SIL CL, performance level, and category) that can be achieved is specified for each connection example.



Please also refer to "Achievable safety depending on the modules used" on page A-30.

SIL/SIL CL



Use the relevant standard to determine the probability of failure in your application according to EN 61508 (SIL) and EN 62061 (SIL CL).

When the SIL/SIL CL is specified, the module takes up 1% of the specified SIL/SIL CL.

Table 6-3 PFD and PFH depending on the SIL/SIL CL

	PFD	PFH
SIL 2/SIL CL 2	1% of 10^{-2}	1% of 10^{-6}
SIL 3/SIL CL 3	1% of 10^{-3}	1% of 10^{-7}

Performance level



Use standard EN ISO 13849-1 to determine the performance level in your application.

Category

In order to actually achieve the specified category, the required measures listed below must be implemented.

Cat. 2

- Use proven and basic safety principles according to EN ISO 13849-2.
- Use appropriately qualified actuators (see "Requirements for controlled devices/actuators" on page 2-4).
- Please note that mechanical failure of the switching device can result in the loss of the safety function.
- Prevent the welding of contacts on the connected contactors or safety relays with appropriate protection against overcurrent and surge voltage.
- Please note that **a single** error can result in the loss of the safety function between tests.
- Ensure that the external wiring is tested by the machine control system on machine startup and at suitable intervals. This test must detect the loss of the safety function.
- In the event of an error, either safe disconnection must be implemented or a warning (optical and/or audible) must be generated depending on the application.

IB IL 24 LPSDO 8 V2-PAC

Cat. 3

- Use proven and basic safety principles according to EN ISO 13849-2.
- Use appropriately qualified actuators (see "Requirements for controlled devices/actuators" on page 2-4).
- Please note that mechanical failure of the switching device can result in the loss of the safety function.
- Prevent the welding of contacts on the connected contactors or safety relays with appropriate protection against overcurrent and surge voltage.
- All errors that cannot be detected can result in the loss of the safety function. Take appropriate measures to prevent such errors. Suitable measures include, for example, protected cable installation or double insulation. Please note the information in the following tables.
- Please take into consideration errors with a common cause.
- Ensure that **a single** error does not result in the loss of the safety function.

Cat. 4

- Use proven and basic safety principles according to EN ISO 13849-2.
- Use appropriately qualified actuators (see "Requirements for controlled devices/actuators" on page 2-4).
- Please note that mechanical failure of the switching device can result in the loss of the safety function.
- Prevent the welding of contacts on the connected contactors or safety relays with appropriate protection against overcurrent and surge voltage.
- An accumulation of errors must not result in the loss of the safety function. Following the third error, evaluation can be aborted if the probability of further errors occurring is low.
- All errors that cannot be detected can result in the loss of the safety function. Take appropriate measures to prevent such errors. Suitable measures include, for example, protected cable installation or double insulation. Please note the information in the following tables.
- Please take into consideration errors with a common cause.

6.4 Single-channel assignment of safe outputs

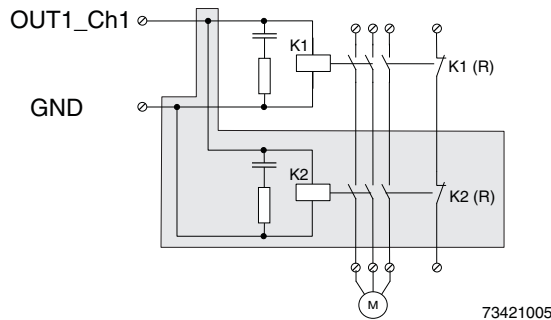

Figure 6-2 Single-channel assignment of outputs



- In order to achieve Cat. 3 or PL d with single-channel assignment of the outputs, a two-channel actuator must be used. The two-channel operation of the actuator with the corresponding connection is represented on a gray background.
- The failure detection time is 20 ms. This means that high pulses of this width can occur in the event of an error. If the application responds to these pulses, use the two-channel assignment of the outputs.

K1 (R) and K2 (R) represent the positively driven N/C contacts for monitoring the state of the relay (readback contacts). Connect these contacts via safe digital inputs. Evaluate the readback and thus the state of the switching elements in the safety logic.



WARNING: Loss of safety function

Connect the actuator ground directly to terminal point GND of the safety module. An external ground may not be used.

Basic specifications

Actuator	Single-channel	Two-channel
Achievable SIL/SIL CL/Cat./PL	SIL 2/SIL CL 2/Cat. 2/PL c	SIL 2/SIL CL 2/Cat. 3/PL d



WARNING: Loss of electrical and functional safety

- To achieve the specified safety integrity level, please refer to "Measures required to achieve a specific safety integrity level" on page 6-3.
- Please note that in order to achieve the specified PL, the actuator must have a medium level of diagnostic coverage (90% to 99%) and medium MTTFd. A high level of diagnostic coverage (> 99%) is recommended for the application according to PL d.
- To achieve Cat. 3 and PL d the test pulses must be enabled.
- Use actuators that can achieve the required safety integrity level.
- Evaluate the readback contacts to achieve the corresponding safety integrity level.

IB IL 24 LPSDO 8 V2-PAC



Enable the test pulses to improve device diagnostics.

If the test pulses for the actuator are faulty, they can be disabled. In this case, test the switching capability of the outputs at regular intervals.

Device diagnostics and behavior of the module in the event of an error

Table 6-4 Single-channel: Test pulses enabled

Error type	Detection	Diagnostics	Loss of SF	Remark
Error in the actuator				
Despite being disabled, the actuator does not switch to the safe state (e.g., a contact will not open)	No	None	Yes	Detect errors using external monitoring. Please take into consideration all the possible errors for the actuator used. Test the shutdown capability of the actuator at regular intervals. If necessary, use a two-channel actuator.
Actuator cannot be enabled (e.g., interrupt)	No	None	No	Detect errors using external monitoring. Please take into consideration all the possible errors for the actuator used. Ensure that this error does not result in delayed system startup.
Other errors (depending on the actuator)				Please take into consideration all possible errors that can occur in the actuator.
Error in the wiring				
Interrupt				
Cable interrupt between output and actuator or between actuator and ground	No	None	No	Detect errors using external monitoring. Please take into consideration all the possible errors for the actuator used. Ensure that this error does not result in delayed system startup.
Cross circuit				
Output to output	Yes	All LEDs OUT: Red ON	Yes	When the outputs are disabled, a cross circuit between the outputs is only detected if the test pulses are enabled. If an error is detected, the module disables all its outputs.
Short circuit				
Output to ground or output to FE	Yes	Short circuit or overload, OUTx	No	The error is detected in the ON state. The output is disabled (safe state). The module cannot be switched on again with an edge from "0" to "1" until the error has been removed and acknowledged. <div style="border: 1px solid black; padding: 5px; display: inline-block;">  <p>WARNING: Unexpected machine startup An operator acknowledgment leads to a positive edge and can thus result in the outputs being re-enabled.</p> </div>

Connection examples for safe outputs
Typical parameterization

Parameterization	Parameterized as	Remark
Assignment	Assigned	
Output	Single-channel	
Switch-off delay for stop category 1	Enabled	Or disabled
Switch-off delay for stop category 1	30	Application-specific
Value range of switch-off delay for stop category 1	Value in s	Application-specific
Test pulses (output disabled) (in software: test impulses (output switched off))	Enabled	Or disabled

According to the "Value range of switch-off delay for stop category 1" and "Switch-off delay for stop category 1" parameters, in this example, the switch-off delay is $30 * 1 \text{ s} = 30 \text{ s}$.

6.5 Two-channel assignment of safe outputs

For two-channel assignment of the safe outputs, two adjacent outputs are always used. This assignment is fixed and cannot be parameterized (see "Two-channel" on page 5-2).

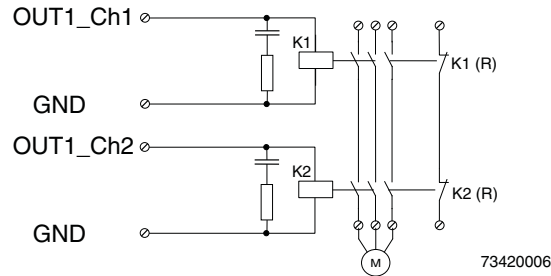

Figure 6-3 Two-channel assignment of outputs

K1 (R) and K2 (R) represent the positively driven N/C contacts for monitoring the state of the relay (readback contacts). Connect these contacts via safe digital inputs. Evaluate the readback and thus the state of the switching elements in your safety logic.



WARNING: Loss of safety function

- Connect the actuator ground directly to terminal point GND of the safety module. An external ground may not be used.
- The failure detection time is 20 ms. This means that high pulses of this width can occur at the faulty output (channel) in the event of an error. The two-channel assignment means that this does not result in a hazardous state.

Basic specifications

Actuator	Two-channel
Achievable SIL/SIL CL/Cat./PL	SIL 3/SIL CL 3/Cat. 4/PL e



WARNING: Loss of electrical and functional safety

- To achieve the specified safety integrity level, please refer to "Measures required to achieve a specific safety integrity level" on page 6-3.
- Please note that in order to achieve the specified PL, the actuator must have a medium level of diagnostic coverage (90% to 99%) and medium MTTFd. A high level of diagnostic coverage (> 99%) is recommended for the application according to PL d.
- Use actuators that can achieve the required safety integrity level.
- Evaluate the readback contacts to achieve Cat. 3 or Cat. 4.
- If the test pulses are disabled:
Test the outputs and external wiring by enabling the outputs at regular intervals. The time between two tests must not exceed eight hours.

Connection examples for safe outputs



Enable the test pulses to improve device diagnostics.
If the test pulses for the actuator are faulty, they can be disabled. In this case, test the switching capability of the outputs at regular intervals.

Device diagnostics and behavior of the module in the event of an error

Table 6-5 Two-channel

Error type	Detection	Diagnostics	Loss of SF	Remark
Error in the actuator				
Despite being disabled, a switching element of the two-channel actuator does not switch to the safe state (e.g., a contact will not open)	No	None	No	No loss of the safety function as the second switching element of the two-channel actuator can be disabled. Detect errors using external monitoring. Implement a restart inhibit in the event of this error. Please take into consideration all the possible errors for the actuator used. Test the shutdown capability of the actuator at regular intervals.
Actuator cannot be enabled (e.g., interrupt)	No	None	No	Detect errors using external monitoring. Please take into consideration all the possible errors for the actuator used. Ensure that this error does not result in delayed system startup.
Other errors (depending on the actuator)				Please take into consideration all possible errors that can occur in the actuator.
Error in the wiring				
Interrupt				
Cable interrupt between output and actuator or between actuator and ground	No	None	No	Detect errors using external monitoring. Please take into consideration all the possible errors for the actuator used. Ensure that this error does not result in delayed system startup.
Cross circuit				
Output to output	Yes (conditional)	All LEDs OUT: Red ON	No	When the outputs are disabled, a cross circuit between the outputs is only detected if the test pulses are enabled. If an error is detected, the module disables all its outputs. If the test pulses have been disabled, test the circuit and the external wiring at regular intervals by enabling the outputs.
Short circuit				
Output to ground or output to FE	Yes	Short circuit or overload, OUTx	No	The error is detected in the ON state. The output is disabled (safe state). The module cannot be switched on again with an edge from "0" to "1" until the error has been removed and acknowledged. <div style="border: 1px solid black; padding: 5px; display: inline-block;"> WARNING: Unexpected machine startup An operator acknowledgment leads to a positive edge and can thus result in the outputs being re-enabled.</div>

IB IL 24 LPSDO 8 V2-PAC

Typical parameterization

Parameterization	Parameterized as		Remark
	Channel 1	Channel 2	
Assignment	Assigned	Assigned	
Output	Two-channel	Two-channel	
Switch-off delay for stop category 1	Enabled	Enabled	Or disabled
Switch-off delay for stop category 1	30	30	Application-specific
Value range of switch-off delay for stop category 1	Value in s	Value in s	Application-specific
Test pulses (output disabled) (in software: test impulses (output switched off))	Enabled	Enabled	

According to the "Value range of switch-off delay for stop category 1" and "Switch-off delay for stop category 1" parameters, in this example, the switch-off delay is $30 * 1 \text{ s} = 30 \text{ s}$.

7 Startup and validation

7.1 Initial startup

Parameterization and configuration must already have been carried out

Table 7-1 Steps for parameterization and configuration (via SAFECONF)

Step	Relevant section and literature
Parameterization and configuration must already have been carried out before commencing startup.	
Carry out the necessary parameterization.	"Parameterization of the safety module" on page 5-1
Make the necessary parameterization settings for the island satellites.	User manuals for the modules used
Configure the safety function.	Online help in SAFECONF

To start up, proceed as described in Table 7-2.

Table 7-2 Steps for startup

Step	Relevant section and literature
Set the transmission speed and the operating mode.	"Setting the DIP switches" on page 4-2
Set the address.	"Setting the DIP switches" on page 4-2
Install the safety module within the Inline station.	"Assembly, removal, and electrical installation" on page 4-1
Connect the bus system and supply voltage cables to the Inline station.	IL SYS INST UM E user manual or documentation for the bus coupler
Wire the outputs according to your application.	"Assembly, removal, and electrical installation" on page 4-1 "Inline potential and data routing, and Inline connectors" on page 3-1 User manuals for the function blocks used
Before applying the operating voltage: <ul style="list-style-type: none"> – Ensure that there are no wiring errors (e.g., cross circuit or short circuit) or grounding errors by testing with a multimeter. – Check whether the ground connection is safe. 	
Connect the required voltages to the Inline station.	IL SYS INST UM E user manual or documentation for the bus coupler, the Inline Controller, or the power terminal

IB IL 24 LPSDO 8 V2-PAC

Table 7-2 Steps for startup (continued)

Step	Relevant section and literature
Once the operating voltage has been applied: <ul style="list-style-type: none"> <li data-bbox="159 373 786 430">– If possible, measure the wave form of the voltages to ensure that there are no deviations. <li data-bbox="159 436 786 552">– Measure the output voltages on the module, as well as the supply voltages, which supply the connected loads (e.g., motor) to ensure that they are in the permissible range. <li data-bbox="159 558 786 674">– Use the LEDs on the devices to check that the module starts up without any errors (there must be no red LEDs permanently on; the FS LED flashes because the device is not parameterized). 	
Check the assembly and installation.	Checklist "Assembly, removal, and electrical installation" on page 4-1
Implement data flow between the standard controller and the safety modules and between the safety modules themselves.	"Implementation of data flow between the standard controller and the safety modules" on page A-22
Download the parameterization and configuration data from the standard controller to the safety modules.	"Downloading the configuration and parameter data record following power up" on page A-27
Perform a function test and validation. Check whether the safety function responds as planned during configuration and parameterization.	Checklist "Validation" on page B-11

When connecting the supply voltages, use the diagnostic and status indicators to check whether the module has started up correctly or whether any errors are indicated. For instructions on how to proceed in the event of an error, please refer to "Errors: Messages and removal" on page 8-1.

7.2 Restart after replacing a safety module

7.2.1 Replacing a safety module

**WARNING: Unintentional machine startup**

Do not assemble or remove the module while the power is connected.

Before assembling or removing the module, disconnect the power to the module and the entire Inline station and ensure that it cannot be switched on again.

Make sure the entire station is reassembled before switching the power back on.

Observe the diagnostic indicators and any diagnostic messages.

The system may only be started provided neither the station nor the system poses a hazard.

If replacing a module, proceed as described for assembly and removal (see "Assembly, removal, and electrical installation" on page 4-1).

Ensure that the new safety module is mounted at the correct position in the local bus. The new module must meet the following requirements:

- Same device type
- Same or later version

Carry out a validation and perform a function test after replacing the module.

7.2.2 Restart

Once the safety module has been replaced, proceed as described for initial startup (see "Initial startup" on page 7-1).

Plug the Inline connectors into the correct connections.

Carry out a validation and perform a function test after replacing the module

7.3 Validation

Carry out a safety validation every time you make a safety-related modification to the SafetyBridge system.

When validating your EUC, check the assignment of the individual actuator connections.

Determine whether:

- The correct safe actuators are connected to the safety module
- The safety module has been parameterized correctly
- The signals used in your safety logic have been linked to the safe actuators correctly

Perform a function test and error simulation.

Please follow the checklist "Validation" on page B-11 during validation.

8 Errors: Messages and removal

Depending on the error type, errors that are diagnosed are displayed via the local diagnostic indicators and/or transmitted to the controller as diagnostic messages.

The tables below provide an overview of the diagnosed errors, their causes, effects, and possible measures for error removal.

In this manual, diagnostic codes are sorted in ascending order by error type. The following errors are possible:

Table 8-1 Overview of diagnostic codes

Diagnostic code	Error type	See
X010 ... X0AA	Safe digital output errors	Section 8.1 on page 8-4
X1F0	Supply voltage errors	Section 8.2 on page 8-5
X1F2	General errors	Section 8.5 on page 8-7
X230 ... X2F2	Parameterization errors	Section 8.4 on page 8-6
X3FC ... X7C4	Connection errors to satellites	Section 8.5 on page 8-7

For every error that occurs, the cause of the error must first be removed. If necessary, the error is then acknowledged. Errors that must be acknowledged are indicated in the "Acknowledgment" column in the tables below.



If diagnostic codes are indicated by the system, which do not appear in the tables below, please contact Phoenix Contact.

Error removal

To remove the cause of an error, please proceed as described in the "Remedy" column in the tables below.

Error acknowledgment

Instructions on how to acknowledge an error can be found in "Acknowledging an error" on page 8-8.



WARNING: Unexpected machine startup

An operator acknowledgment leads to a positive edge and can thus result in the outputs being re-enabled.

IB IL 24 LPSDO 8 V2-PAC

Notes on the tables below

Diagnostic code

The diagnostic register of the module includes both status bits and the diagnostic code (see "Dev-Diag-LPSDO (LPSDO diagnostics)" on page A-18). This diagnostic code, which is shown in bits 10 to 0 of the register, is listed in the tables below starting from Table 8-4). However, it is the code of the entire diagnostic register that is indicated. To obtain the diagnostic code specified in the documentation, logically AND the code of the diagnostic register indicated with the code 07FF_{hex}.

Example: ANDing the diagnostic code

Diagnostic code indicated: 2290_{hex}

Table 8-2 Relationship between the diagnostic code indicated and the diagnostic code specified in the documentation

		15	14	13	12	11	10	...								0					
Assignment of the diagnostic register (see page A-18)		COK	SA	E	PUR	OAR	Diagnostic code														
Diagnostic code indicated	hex	2				2		9				0									
	bin	0	0	1	0	0	0	1	0	1	0	0	1	0	0	0	0				
Mask (07FF _{hex})	bin	0	0	0	0	0	1	1	1	1	1	1	1	1	1	1	1				
Diagnostic code in the documentation	bin	0	0	0	0	0	0	1	0	1	0	0	1	0	0	0	0				
	hex	0 -> X (not relevant)				2		9				0									

Diagnostic code specified in the documentation: X290_{hex} (see Table 8-8 on page 8-6).

As the first digit is never relevant, the code always starts with an X.

If the same error can occur at different outputs/channels, a generalizing diagnostic code is indicated with an n where the error location is specified.

Generalizing diagnostic code specified in the documentation: X03n_{hex}

For some errors a single channel is specified as the error location (e.g., OUT0_Ch1). Some errors only occur for outputs parameterized for two-channel operation. Here, the channel pair is specified as the error location (e.g., OUT0_Ch1&2).

Example: Channels in the diagnostic code

Safe output errors (Table 8-4)

Error cause	Diagnostic code (hex)
Short circuit or overload	003n
X030: OUT0_Ch1	X037: OUT0_Ch2
X031: OUT1_Ch1	X038: OUT1_Ch2
X032: OUT2_Ch1	X039: OUT2_Ch2
X033: OUT3_Ch1	X03A: OUT3_Ch2

003n Short circuit or overload

003n Error location

This means, for example:

X032 Cross circuit at OUT2_Ch1 (output 2 channel 1)

X03A Cross circuit at OUT3_Ch2 (output 3 channel 2)

Example: ANDing the diagnostic code

Diagnostic code indicated: 0D03_{hex}

Table 8-3 Relationship between the diagnostic code indicated and the diagnostic code specified in the documentation

		15	14	13	12	11	10	...								0					
Assignment of the diagnostic register (see page A-18)		COK	SA	E	PUR	OAR	Diagnostic code														
Diagnostic code indicated	hex	0				D			0				3								
	bin	0	0	0	0	1	1	0	1	0	0	0	0	0	0	1	1				
Mask (07FF _{hex})	bin	0	0	0	0	0	1	1	1	1	1	1	1	1	1	1	1				
Diagnostic code in the documentation	bin	0	0	0	0	0	1	0	1	0	0	0	0	0	0	1	1				
	hex	0 -> X (not relevant)				5			0				3								

Diagnostic code specified in the documentation: X503_{hex} (see Table 8-9 on page 8-7).

LED

The "LED" column specifies which local diagnostic LEDs indicate the error.

Acknowledgment

To remove the error, evaluate the PUR and OAR bits in the diagnostic register of the IB IL 24 LPSDO 8 V2-PAC (see "Dev-Ack-x (device acknowledgment)" on page A-17). These specify whether a power up is expected or whether an acknowledgment is required.

Errors that must be acknowledged are indicated with "Yes" in the "Acknowledgment" column. Special conditions for re-enabling an output or the module are specified in brackets [e.g., Yes (1)] in the "Acknowledgment" column and explained below the relevant table.



For information about acknowledging satellite errors, see "Acknowledgment of error messages for satellites" on page A-25.

IB IL 24 LPSDO 8 V2-PAC

8.1 Safe digital output errors

Table 8-4 Safe output errors

Error cause	Diagnostic code (hex)	LED	Remark	Effect	Remedy	Acknowledgment
Hardware fault X010: OUT0_Ch1 X011: OUT1_Ch1 X012: OUT2_Ch1 X013: OUT3_Ch1	X01n X017: OUT0_Ch2 X018: OUT1_Ch2 X019: OUT2_Ch2 X01A: OUT3_Ch2	All OUT: Red ON	The indicated output cannot be disabled	All module outputs are in the safe state	Power up with error-free selftest Replacement	Yes (1)
Short circuit or overload X030: OUT0_Ch1 X031: OUT1_Ch1 X032: OUT2_Ch1 X033: OUT3_Ch1	X03n X037: OUT0_Ch2 X038: OUT1_Ch2 X039: OUT2_Ch2 X03A: OUT3_Ch2	OUTy: Red ON		Affected output is in the safe state	Check actuator Check connector and cabling Check free running circuit at the contactor	Yes (2)
Error at the output or short circuit during the test X050: OUT0_Ch1 X051: OUT1_Ch1 X052: OUT2_Ch1 X053: OUT3_Ch1	X05n X057: OUT0_Ch2 X058: OUT1_Ch2 X059: OUT2_Ch2 X05A: OUT3_Ch2	All OUT: Red ON	Pulse test (brief activation) at the output failed	All module outputs are in the safe state	Power up with error-free selftest Replacement	Yes (1)
Error at the output during the test X060: OUT0_Ch1 X061: OUT1_Ch1 X062: OUT2_Ch1 X063: OUT3_Ch1	X06n X067: OUT0_Ch2 X068: OUT1_Ch2 X069: OUT2_Ch2 X06A: OUT3_Ch2	All OUT: Red ON	Pulse test (brief deactivation) at the output failed	All module outputs are in the safe state	Power up with error-free selftest Replacement	Yes (1)
Hardware fault	X091	All OUT: Red ON	Detected by internal tests.	All module outputs are in the safe state	Power up with error-free selftest Replacement	Yes (1)
Cross circuit at the indicated output X0A0: OUT0_Ch1 X0A1: OUT1_Ch1 X0A2: OUT2_Ch1 X0A3: OUT3_Ch1	X0An X0A7: OUT0_Ch2 X0A8: OUT1_Ch2 X0A9: OUT2_Ch2 X0AA: OUT3_Ch2	All OUT: Red ON	Cross circuit with another output or with an external signal	All module outputs are in the safe state	Remove error Power up with error-free selftest	Yes (1)

Acknowledge all errors that are present. Only then can the outputs be re-enabled.

Acknowledgment: Yes (1)

Acknowledging the diagnostic message deletes the message. The module can only be restarted following power up and error-free selftest.

Acknowledgment: Yes (2) Acknowledging the diagnostic message deletes the message and enables a restart. Following successful acknowledgment, the module also expects a positive edge from the application for the output.



WARNING: Unexpected machine startup

An operator acknowledgment leads to a positive edge and can thus result in the outputs being re-enabled.

8.2 Supply voltage errors

Table 8-5 Supply voltage U_M errors

Error cause	Diagnostic code (hex)	LED	Remark	Effect	Remedy	Acknowledgment
Undervoltage U_M	X1F0	UM flashing	U_M below the permissible voltage range	All module outputs are in the safe state	Check supply voltage level and correct Check supply line length and load	Yes (1)

Acknowledgment: Yes (1) Acknowledging the diagnostic message deletes the message and activates the outputs.

Undervoltage at U_M : Supply voltage U_M is measured. If $U_M < 17\text{ V}$, a diagnostic message is generated.

8.3 General errors

Table 8-6 General errors

Error cause	Diagnostic code (hex)	LED	Remark	Effect	Remedy	Acknowledgment
Device temperature at critical value	X1F2			Immediate shutdown. Further temperature increase causes the module to switch to the safe state.	Check and adapt: <ul style="list-style-type: none"> – Ambient conditions – Derating – Output loads – Switching frequency 	Yes (1)
Hardware fault		FS ON	Error in the logic area	Module is in the safe state	Replacement	
			Impermissible DIP switch position	Module is in the safe state	Check and correct switch position	

Acknowledgment: Yes (1) Acknowledging the diagnostic message deletes the message.

Acknowledgment: Yes (2) Acknowledging the diagnostic message deletes the message and enables the outputs.

IB IL 24 LPSDO 8 V2-PAC

8.4 Parameterization errors

Table 8-7 Parameterization errors

Error cause	Diagnostic code (hex)	LED	Remark	Effect	Remedy	Acknowledgment
Incorrect parameterization	See Table 8-8	FS (flashing)	Each output is parameterized individually	Module is in the safe state	Check and correct parameterization.	–

In order to determine what type of parameterization error has occurred, use the corresponding software to access the controller online and read the error (see "Description of the registers" on page A-17).

Proceed as follows, e.g., in the SafetyBridge system:

- The diagnostic LEDs indicate that an error has occurred.
- Go online to the higher-level standard controller.
For each module of the SafetyBridge island, a diagnostic register is mapped to the process image of the IB IL 24 LPSDO 8 V2-PAC (see "Description of the registers" on page A-17).
From this, determine the module of the safety island in which an error has occurred.
- Evaluate the specified diagnostic code.

Table 8-8 Parameterization errors

Diagnostic code		Short description	Remedy
(hex)	(dec)		
X23n X230: OUT0_Ch1&2 X231: OUT1_Ch1&2 X232: OUT2_Ch1&2 X233: OUT3_Ch1&2	560: OUT0_Ch1&2 561: OUT1_Ch1&2 562: OUT2_Ch1&2 563: OUT3_Ch1&2	The parameterization of two related outputs does not correspond to the two-channel setting.	Correct value and resend parameter data to the module.
X28n X280: OUT0_Ch1 X281: OUT1_Ch1 X282: OUT2_Ch1 X283: OUT3_Ch1 X287: OUT0_Ch2 X288: OUT1_Ch2 X289: OUT2_Ch2 X28A: OUT3_Ch2	640: OUT0_Ch1 641: OUT1_Ch1 642: OUT2_Ch1 643: OUT3_Ch1; 647: OUT0_Ch2 648: OUT1_Ch2 649: OUT2_Ch2 650: OUT3_Ch2	The parameterized switch-off delay time for the output is outside the permissible value range.	Correct value and resend parameter data to the module.
X29n X290: OUT0_Ch1&2 X291: OUT1_Ch1&2 X292: OUT2_Ch1&2 X293: OUT3_Ch1&2	656: OUT0_Ch1&2 657: OUT1_Ch1&2 658: OUT2_Ch1&2 659: OUT3_Ch1&2	For outputs parameterized for two-channel operation, the same settings were not assigned for the switch-off delay.	Correct setting and resend parameter data to the module.
X2Bn X2B0: OUT0_Ch1&2 X2B1: OUT1_Ch1&2 X2B2: OUT2_Ch1&2 X2B3: OUT3_Ch1&2	688: OUT0_Ch1&2 689: OUT0_Ch1&2 690: OUT0_Ch1&2 691: OUT3_Ch1&2	For outputs parameterized for two-channel operation, the same settings were not assigned for enabling.	Correct setting and resend parameter data to the module.
X2F2	754	At least one output with parameterized switch-off delay is still performing a switch-off operation.	Wait until the switch-off operation is complete and resend parameter data to the module.

8.5 Connection errors to satellites

Table 8-9 Connection errors to satellites

Error cause	Diagnostic code	Short description	Remedy	Acknowledgment
(hex)	(hex)			
Wrong island number	X3FC	Island number at IB IL 24 LPSDO 8 V2-PAC not set correctly	Check switch position and value in software and adapt accordingly.	Reload project.
Communication connection faulty	X5nn	One or more safe communication connections are faulty, see Table 8-10.	Check and adapt data status and copy routines.	Acknowledgment required. (The OAR bit is set in the diagnostic register of the IB IL 24 LPSDO 8 V2-PAC; see "Dev-Diag-LPSDO (LPSDO diagnostics)" on page A-18)
Incorrect F_Source_Address	X7C2	IB IL 24 LPSDO 8 V2-PAC address settings in the software and on the device do not match.	Check switch position and value in software and adapt accordingly.	Power up. (The PUR bit is set in the diagnostic register of the IB IL 24 LPSDO 8 V2-PAC; see "Dev-Diag-LPSDO (LPSDO diagnostics)" on page A-18)
Incorrect operating mode	X7C3	The operating mode set on the device is not supported.	Check and correct switch position.	
Incorrect F_Source_Address	X7C4	The F_Source_Address set on the device is not within the permissible value range.	Check and correct switch position.	
Communication connection faulty	XDnn	See X5nn, the OAR bit is set in the diagnostic register of the IB IL 24 LPSDO 8 V2-PAC		

Table 8-10 Diagnostic codes for faulty communication connection

OAR bit		Diagnostic code bit 0 ... 4						Faulty connection to satellite ...					OAR bit		Diagnostic code bit 0 ... 4						Faulty connection to satellite ...				
= 0	= 1	4	3	2	1	0	5	4	3	2	1	0	= 0	= 1	4	3	2	1	0	5	4	3	2	1	0
X501	XD01	0	0	0	0	1							X511	XD11	1	0	0	0	1	X					X
X502	XD02	0	0	0	1	0				X			X512	XD12	1	0	0	1	0	X			X		
X503	XD03	0	0	0	1	1				X	X		X513	XD13	1	0	0	1	1	X			X	X	
X504	XD04	0	0	1	0	0				X			X514	XD14	1	0	1	0	0	X		X			
X505	XD05	0	0	1	0	1				X		X	X515	XD15	1	0	1	0	1	X		X		X	
X506	XD06	0	0	1	1	0				X	X		X516	XD16	1	0	1	1	0	X		X	X		
X507	XD07	0	0	1	1	1				X	X	X	X517	XD17	1	0	1	1	1	X		X	X	X	X
X508	XD08	0	1	0	0	0		X					X518	XD18	1	1	0	0	0	X	X				
X509	XD09	0	1	0	0	1		X			X		X519	XD19	1	1	0	0	1	X	X			X	
X50A	XD0A	0	1	0	1	0		X		X			X51A	XD1A	1	1	0	1	0	X	X		X		
X50B	XD0B	0	1	0	1	1		X		X	X		X51B	XD1B	1	1	0	1	1	X	X		X	X	
X50C	XD0C	0	1	1	0	0		X	X				X51C	XD1C	1	1	1	0	0	X	X	X			
X50D	XD0D	0	1	1	0	1		X	X		X		X51D	XD1D	1	1	1	0	1	X	X	X		X	
X50E	XD0E	0	1	1	1	0		X	X	X			X51E	XD1E	1	1	1	1	0	X	X	X	X		
X50F	XD0F	0	1	1	1	1		X	X	X	X		X51F	XD1F	1	1	1	1	1	X	X	X	X	X	X

8.6 Acknowledging an error

In the SafetyBridge system, the errors of the IB IL 24 LPSDO 8 V2-PAC as well as those of the corresponding island satellites must be acknowledged via the IB IL 24 LPSDO 8 V2-PAC.

After removing the cause of an error, the diagnostic message must be acknowledged. To do this, set the corresponding bit in the "Dev-Ackn-LPSDO" register (see "App-Diag-LPSDO (application diagnostics)" on page A-19).



WARNING: Acknowledgment may result in a hazardous system state

With the exception of a few special cases, the acknowledgment of an error immediately returns the safe input or output to the operating state. Before acknowledging an error you must, therefore, make sure that the acknowledgment will not cause the machine to switch to a dangerous state.

When planning the machine or system, make sure that acknowledgment is only possible if the danger zone is visible.

If in the event of failure the safety module is replaced, please proceed as described in Section 4, "Assembly, removal, and electrical installation" and "Restart after replacing a safety module" on page 7-3.

9 Maintenance, repair, decommissioning, and disposal

9.1 Maintenance

The device is designed in such a way that maintenance work is not required during the duration of use. However, depending on the application and connected I/O devices it may be necessary to test the function of the I/O devices and the safety chain at regular intervals.

The duration of use of the module is 20 years.

Repeat testing within this time is not required.

Carry out maintenance of connected I/O devices (e.g., light grid) according to the relevant manufacturer specifications.

9.2 Repair

Repair work may not be carried out on the safety module. In the event of an error, send the module to Phoenix Contact.

It is strictly prohibited to open the safety module. In order to prevent the manipulation of the module and to detect the unauthorized opening of the module, a security seal is applied to the module. This security seal is damaged in the event of unauthorized opening. In this case, the correct operation of the safety module can no longer be ensured.

9.3 Decommissioning and disposal

The machine or system manufacturer specifies the procedure for decommissioning. Decommissioning may only take place according to these specified procedures.

When decommissioning a SafetyBridge system or parts thereof, ensure that the safety modules used:

- Are correctly reused in another system.
In this case, please observe the storage and transport requirements according to the technical data (see "IB IL 24 LPSDO 8 V2-PAC" on page 10-1).
- Or**
- Are disposed of according to the applicable environmental regulations, and in this case can never be reused.

10 Technical data and ordering data

10.1 System data

10.1.1 Inline



For system data, please refer to the following user manual:

Inline Automation terminals of the Inline product range
IL SYS INST UM E

10.1.2 SafetyBridge system

SafetyBridge system	
Shutdown time t_{OUT_LPSDO}	10 ms
Maximum number of SafetyBridge islands in the system	31
Maximum number of modules within a SafetyBridge island	1 IB IL 24 LPSDO 8 V2-PAC 5 satellites (IB IL 24 PSDI 8-PAC, IB IL 24 PSDO ...-PAC, mixed at will)
Memory capacity	20 kB for safety logic

10.2 IB IL 24 LPSDO 8 V2-PAC

General data	
Housing dimensions (width x height x depth)	48.8 mm x 119.8 mm x 71.5 mm
Weight (with connectors)	200 g
Operating mode	
SafetyBridge	Process data mode with 16 or 24 words
SafetyBridge multiplexer	Process data mode with 8 words
Transmission speed (local bus)	500 kbaud or 2 Mbaud
Ambient temperature	
Operation	-25°C to +55°C
Storage/transport:	-25°C to 70°C
Humidity	
Operation	75% on average, 85% occasionally (no condensation)
	In the range from -25°C to +55°C appropriate measures against increased humidity must be taken.
Storage/transport:	75% on average; 85% occasionally (no condensation)
	For a short period, slight condensation may appear on the outside of the housing.

IB IL 24 LPSDO 8 V2-PAC**General data (continued)**

Air pressure

Operation	80 kPa to 108 kPa (up to 2000 m above sea level)
Storage/transport:	66 kPa to 108 kPa (up to 3500 m above sea level)
Degree of protection	IP20
Housing material	Plastic PBT, self-extinguishing (V0)
Air and creepage distances	According to IEC 60439-1, derived from IEC 60664-1
Protection class	III (PELV)
Gases that may endanger functions according to DIN 40046-36, DIN 40046-37	
Sulfur dioxide (SO ₂)	Concentration 10 ±0.3 ppm Ambient conditions: – Temperature 25°C ±2 K – Humidity 75% ±5% – Test duration 10 days
Hydrogen sulfide (H ₂ S)	Concentration 1 ±0.3 ppm Ambient conditions: – Temperature 25°C ±2 K – Humidity 75% ±5% – Test duration 4 days
Resistance of housing material to termites	Resistant
Resistance of housing material to fungal decay	Resistant
Ambient compatibility	Not resistant to chloroform
Connection data for Inline connectors	
Connection method	Spring-cage terminals
Conductor cross-section	0.2 mm ² to 1.5 mm ² (solid or stranded), 24 - 16 AWG
Supported stop category according to EN 60204	0 1 in error-free state

Mechanical requirements

Vibration according to IEC 60068-2-6	Operation: 2g, Criterion A
Shock according to IEC 60068-2-27	15g over 11 ms, Criterion A

Safety characteristics according to IEC 61508/EN 61508

Achievable SIL	SIL 2 (single-channel) SIL 3 (two-channel) Depends on the parameterization and wiring (see "Connection options for actuators depending on the parameterization" on page 2-5 and "Connection examples for safe outputs" on page 6-1)
Probability of a dangerous failure on demand by the safety function (PFD)	SIL 2: 1% of 10 ⁻² , maximum (corresponds to 1 x 10 ⁻⁴) SIL 3: 1% of 10 ⁻³ , maximum (corresponds to 1 x 10 ⁻⁵)
Probability of a dangerous failure per hour for the entire module (PFH)	SIL 2: 1% of 10 ⁻⁶ , maximum (corresponds to 1 x 10 ⁻⁸) SIL 3: 1% of 10 ⁻⁷ , maximum (corresponds to 1 x 10 ⁻⁹) Depends on the parameterization (see Table 6-3 on page 6-3)
Hardware fault tolerance (HFT) of the module	1
Permissible duration of use	20 years

Technical data and ordering data

Safety characteristics according to DIN EN 62061

Achievable SIL claim limit	SIL CL = SIL 2 (single-channel) SIL CL = SIL 3 (two-channel) Depends on the parameterization and wiring (see "Connection options for actuators depending on the parameterization" on page 2-5 and "Connection examples for safe outputs" on page 6-1)
Safe failure fraction (SFF)	99%
Probability of a dangerous failure per hour for the entire module (PFH)	SIL CL 2: 1 % of 10^{-6} , maximum (corresponds to $1 * 10^{-8}$) SIL CL 3: 1 % of 10^{-7} , maximum (corresponds to $1 * 10^{-9}$) 1 % of 10^{-7} , maximum (corresponds to $1 * 10^{-9}$) Depends on the parameterization (see Table 6-3 on page 6-3)
Hardware fault tolerance (HFT) of the module	1
Permissible duration of use	20 years

Safety characteristics according to EN ISO 13849-1

Achievable performance level	PL e (two-channel) PL d (single-channel) Depends on the parameterization and wiring (see "Connection options for actuators depending on the parameterization" on page 2-5 and "Connection examples for safe outputs" on page 6-1) See also "Achievable safety depending on the modules used" on page A-30.
Diagnostic coverage (DC)	99%
Mean time to dangerous failure (MTTFd)	For single-channel assignment: 100 years For two-channel assignment: 100 years

Supply voltage U_L (logic)



The safety terminal is supplied with communications power via the bus coupler, an Inline controller, or a designated power terminal in the station. Potential routing is used for the communications power in the Inline station. For technical data, please refer to the data sheet for the bus coupler, Inline controller, or power terminal used.

Current consumption	230 mA, maximum
---------------------	-----------------

Supply voltage U_M (actuators)



The safety terminal is supplied with main voltage U_M via the bus coupler, an Inline controller, or a power terminal in the station. Potential routing is used for the main voltage in the Inline station. For technical data, please refer to the data sheet for the bus coupler, Inline controller, or power terminal used.



WARNING: Loss of the safety function when using unsuitable power supplies

Only use power supplies according to EN 50178/VDE 0160 (PELV).

Nominal voltage	24 V DC according to EN 61131-2 and EN 60204
Tolerance	-15%/+20% including an entire AC voltage component with peak value of 5%
Ripple	3.6 V _{pp}
Permissible voltage range	19.2 V DC to 30.0 V DC, ripple included
Current consumption	30 mA, typical (all outputs set) (plus actuator current)

IB IL 24 LPSDO 8 V2-PAC**Supply voltage U_M (actuators) (continued)**

Permissible interruption time	10 ms; Within this time, the output voltage for the safe outputs fails as the outputs are not internally buffered.
Surge protection	Yes (in the bus coupler/power terminal)
Protection against polarity reversal	Yes (in the bus coupler/power terminal)

**NOTE: Module damage due to polarity reversal**

Polarity reversal places a burden on the electronics and, despite protection against polarity reversal, can damage the module. Therefore, polarity reversal must be prevented.

Undervoltage detection	Yes, at 17 V, approximately
Diagnostic indicators	Green U_M LED (see "Local diagnostic and status indicators" on page 2-6)
External fuse protection	Maximum 8 A, slow-blow

**NOTE: Module damage in the event of overload**

The power supply unit must be able to supply four times (400%) the nominal current of the external fuse.

Safe digital outputs OUT0 to OUT3

Number	4 two-channel or 8 single-channel (positive switching)
Supply	From supply voltage U_M
Maximum output current per output	2 A
Maximum output current for all outputs (total current)	6 A (observe derating and maximum output current for each group)
Maximum output current for each group (total current)	
Group 1 (OUT0_K1, OUT1_K1, OUT2_K1, OUT3_K1)	3 A
Group 2 (OUT0_K2, OUT1_K2, OUT2_K2, OUT3_K2)	3 A
Maximum output voltage in the low state	< 5 V

**WARNING: Loss of safety function**

At this voltage, the load must not switch to or remain in the ON state. Please take this into consideration when selecting the actuator.

Maximum leakage current in the low state	2 mA
--	------

**WARNING: Loss of safety function**

At this current, the load must not switch to or remain in the ON state. Please take this into consideration when selecting the actuator.

Minimum withstand voltage of the connected loads	> 5 V
Maximum inductive load	1 H

Safe digital outputs OUT0 to OUT3 (continued)

Maximum capacitive load depending on the current

$C = 1 \text{ s}/(R \times 1400)$
 Where:
 C Load capacity in F
 R Load resistance in ohms

Maximum capacitive load depending on the load current

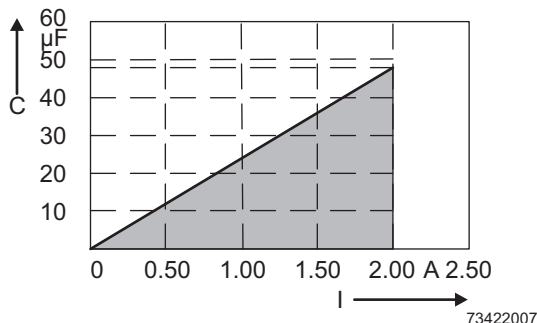

Key:
 C Load capacity in µF
 I Load current in A
 Hatched area: Permissible range

Minimum load	1.5 kΩ (16 mA at 24 V)
Limitation of the voltage induced on circuit interruption	-15 V
Output voltage	$U_M - 1 \text{ V}$, approximately
Simultaneity	100% up to 45°C (observe maximum current load)
Derating	Up to 50°C, total current of all outputs 6 A, maximum Up to 55°C, total current of all outputs 4 A, maximum
Maximum switching frequency	1 Hz; 0.2 Hz at > 1 A
Filter time	None
Switch-off delay for shutdown according to stop category 1	Can be parameterized; 150 ms to 630 s; see "Parameterization of the safe outputs" on page 5-2 Accuracy ±5% of the parameterized value
Maximum duration of the test pulses (when switched off; active driving)	1 ms
Maximum duration of the test pulses (when switched on)	3 ms (depending on the load capacity)
Status indicators	One green LED (two-color LED green/red) per output (see "Local diagnostic and status indicators" on page 2-6)
Diagnostic indicators	One red LED (two-color LED green/red) per output (see "Local diagnostic and status indicators" on page 2-6)



WARNING: Loss of safety function

- Connect the ground of the actuator directly to the ground terminal point of the corresponding output on the Inline connector. An external ground may not be used.
- The connected load must not respond in a hazardous way to test pulses.

IB IL 24 LPSDO 8 V2-PAC**Electrical isolation/Isolation of the voltage areas**

To provide electrical isolation between the logic level and the I/O area, separate power supply units must be used for each of the station bus coupler and this safety module. Interconnection of the power supply units in the 24 V area is not permitted. (See also IL SYS INST UM E user manual.)

Separate potentials in the system comprising bus coupler/power terminal and safety module**- Test distance**

5 V supply incoming remote bus/7.5 V supply (bus logic)

5 V supply outgoing remote bus/7.5 V supply (bus logic)

7.5 V supply (bus logic)/24 V supply U_M , FE**- Test voltage**

500 V AC, 50 Hz, 1 min.

500 V AC, 50 Hz, 1 min.

500 V AC, 50 Hz, 1 min.

Approvals

For the latest approvals, please visit www.phoenixcontact.net/catalog.

10.3 Conformance with EMC Directive**Conformance with EMC Directive 2004/108/EC****Noise immunity test according to DIN EN 61000-6-2**

Electrostatic discharge (ESD)

EN 61000-4-2
(IEC 61000-4-2)

Criterion B

6 kV contact discharge, 8 kV air discharge

Electromagnetic fields

EN 61000-4-3
(IEC 61000-4-3)

Criterion A, field strength 10 V/m

Fast transients (burst)

EN 61000-4-4
(IEC 61000-4-4)

Criterion B, test voltage 2 kV

Surge voltage

EN 61000-4-5
(IEC 61000-4-5)

Test intensity 2, Criterion B

DC supply lines:
0.5 kV/0.5 kV (symmetrical/asymmetrical)Signal lines:
1.0 kV/2.0 kV (symmetrical/asymmetrical)

Conducted interference

EN 61000-4-6
(IEC 61000-4-6)

Criterion A, test voltage 10 V

Noise emission test according to DIN EN 61000-6-4

Noise emission

EN 55011

Class A, industrial applications

10.4 Ordering data

10.4.1 Ordering data: Safety module

Description	Type	Order No.	Pcs. / Pkt.
Inline module with integrated safety logic and safe digital outputs	IB IL 24 LPSDO 8 V2-PAC	2700606	1

10.4.2 Ordering data: Accessories

Description	Type	Order No.	Pcs. / Pkt.
Connector set as replacement item	IB IL 24 SDO 8-PLSET/CP	2916927	1 set
Connector set, consisting of four Inline connectors with integrated discharge electronics	IB IL 24 PSDO 8-PLSET/CP/R	2700722	1 set

10.4.3 Ordering data: Software

Description	Type	Order No.	Pcs. / Pkt.
Parameterization and configuration tool	SAFECONF	2986119	1



The software can be downloaded free of charge from <http://www.phoenixcontact.com/catalog>.

10.4.4 Ordering data: Documentation

Description	Type	Order No.	Pcs. / Pkt.
Inline			
User manual Automation terminals of the Inline product range	IL SYS INST UM E	2698737	1
Quick start guide IB IL 24 LPSDO 8 V2-PAC	UM QS EN IB IL 24 LPSDO 8 V2-PAC	On request	1



Make sure you always use the latest documentation.
It can be downloaded from www.phoenixcontact.net/catalog.

A Appendix: SafetyBridge system

A 1 The SafetyBridge system

A 1.1 SafetyBridge technology – Maximum flexibility and safety

In all safety applications in which conventional safety relays are not flexible enough, parallel wiring proves too complex due to the expansiveness of the safety circuits, or the use of a safe bus system in connection with a safe controller is cost-prohibitive, SafetyBridge technology from Phoenix Contact offers a cost-effective solution.

The SafetyBridge system works independently of the relevant network and the standard control system used. Both simply act as a transport medium for safe data packets, which are exchanged between the safe input and safe output modules. The safe inputs and outputs are distributed in the network and do not require a higher-level safety controller or a separate safety bus system. Therefore, instead of having to choose a safe network such as PROFIsafe or CIP Safety with safety controllers available accordingly, users can instead continue to use the systems or technologies they have come to rely on. This means that a hitherto unseen level of flexibility can be achieved in bus-based safety applications.

Direct processing of safety operations in the module

SafetyBridge technology has been integrated into the proven Inline I/O system. No special installation guidelines have to be observed when installing the corresponding modules. They can be distributed in the network and operated at any point in the I/O station. Due to the technology used, a special bus coupler is not required as the safety operations are processed directly in the IB IL 24 LPSDO 8 V2-PAC intelligent safe output module. Thanks to the comprehensive range of parameterization options, the input or output channels can be adapted flexibly to the relevant application. Data transmission over the network from the safe input module to the output module is protected by a special protocol, which is operated by the intelligent output module. The standard control system simply has to copy standard I/O data bidirectionally between the input and output modules. Like the network used, it does not perform any safety-related tasks.

Easy configuration of the safety logic

The safety mechanisms used in the SafetyBridge system, such as the "black channel" principle, are based on proven technologies that have been used for many years in the INTERBUS-Safety and PROFIsafe systems. With appropriate parameterization, applications up to Cat. 4/SIL 3/SIL CL 3/PL e can be implemented. The SAFECONF software supports user-friendly parameterization of the safe input and output channels and creation of the safety logic. The tool does not require programming experience, as predefined function blocks are available for virtually every application. SafetyBridge technology can be used to implement distributed safety applications cost-effectively in a network independently of the network and standard control system.

IB IL 24 LPSDO 8 V2-PAC**A 1.2 Overview of SafetyBridge system features**

- Network independent
- Controller independent
- No higher-level safety controller required
- Up to five connections to satellites
- All data, including parameterizations, is located on the standard controller
- Only the IB IL 24 LPSDO 8 V2-PAC module is parameterized by the standard controller
- No parameterization required in multiplexer mode
- The SAFECNF parameterization tool can be downloaded free of charge (see "Ordering data" on page 10-7)
- Enable principle
- Standard controller can access all safe signals and diagnostic data

A 1.3 Differences in SafetyBridge systems dependent upon which module with integrated safety logic is used

Table A-1 SafetyBridge system specifications

Functionality	IB IL 24 LPSDO 8-PAC	IB IL 24 LPSDO 8 V2-PAC
Supported networks	<ul style="list-style-type: none"> - INTERBUS - PROFIBUS - PROFINET 	<ul style="list-style-type: none"> - INTERBUS - PROFIBUS - PROFINET - ETHERNET IP - MODBUS TCP - DeviceNet - CANopen - sercos III
Number of safe communications	3 IN	5 IN/OUT (mixed)
Size of memory for safety logic	5 kB	20 kB
Non-volatile memory	No	Yes
Safe function blocks	<ul style="list-style-type: none"> - E-STOP - EDM - GuardMonitoring - TwoHandControl II - EnableSwitch - ESPE 	<ul style="list-style-type: none"> - E-STOP - EDM - GuardMonitoring - TwoHandControl II - EnableSwitch - ESPE - GuardLocking - ModeSelector - TwoHandControl III - TestableSafetySensor - MutingSeq - MutingPar - MutingPar2
Implicit enable	Yes	Yes

Table A-1 SafetyBridge system specifications

Functionality	IB IL 24 LPSDO 8-PAC	IB IL 24 LPSDO 8 V2-PAC
Mirroring of local safe output data	Yes	Yes
Forwarding of safe outputs	No	Yes
Satellites supported	IB IL 24 PSDI 8-PAC	<ul style="list-style-type: none"> - IB IL 24 PSDI 8-PAC - IB IL 24 PSDO 8-PAC - IB IL 24 PSDO 4/4-PAC - IB IL 24 PSDOR 4-PAC Permissible revision see Table 10-1
Multiplexer mode	Yes	Yes
Support of partial configurations	Yes	Yes

Table 10-1 Revision as of which a module is permitted for use on the logic module

Order No.:	Type	Revision as of which a module is permitted for use on	
		IB IL 24 LPSDO 8-PAC	IB IL 24 LPSDO 8 V2-PAC
2985688	IB IL 24 PSDI 8-PAC	00/200	00/200
2985631	IB IL 24 PSDO 8-PAC	-	01/200/100
2985864	IB IL 24 PSDOR 4-PAC	-	01/200/100
2916493	IB IL 24 PSDO 4/4-PAC	-	01/200/100

A 2 System topology

A 2.1 General topology

A SafetyBridge system can be integrated into various bus systems including INTERBUS, PROFINET, and PROFIBUS. The standard bus system is thus supplemented by components to achieve safety.

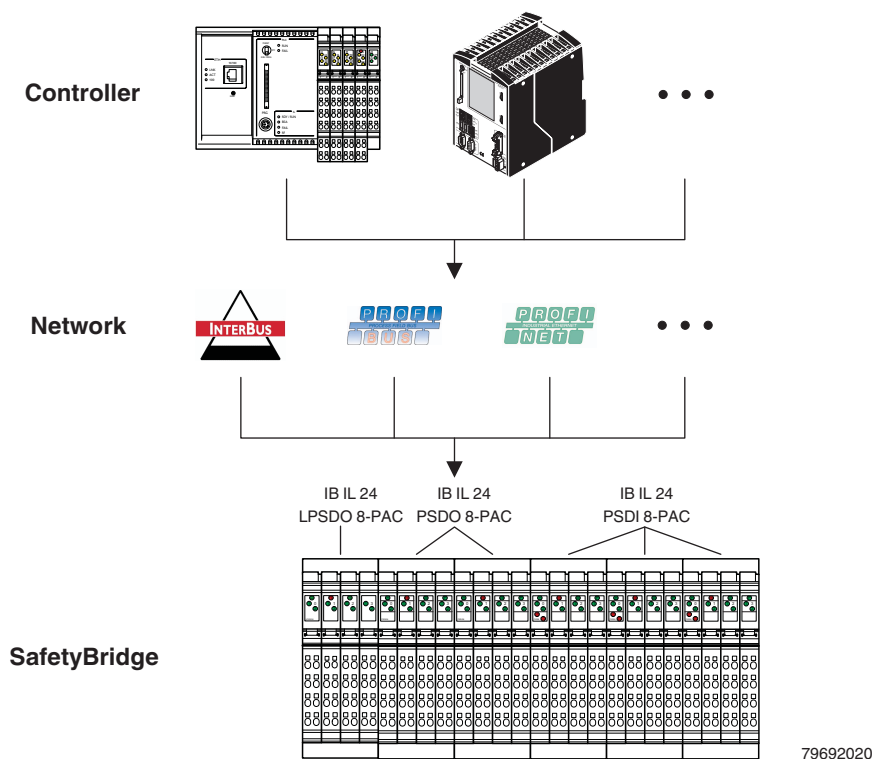

Figure A-1 Network independence

Control level	A standard controller is used (see also "Network and controller requirements" on page A-5).
I/O level	Safe devices are integrated into the Inline station at I/O level. Safe and standard devices can be operated simultaneously in the overall system.
Communication	Communication takes place via the standard controller and the standard bus system using safe data packets.
System	The system comprises a standard controller and up to 31 SafetyBridge islands.

SafetyBridge island

Each SafetyBridge island comprises one SafetyBridge module with integrated safety logic (IB IL 24 LPSDO 8 V2-PAC) and up to five distributed SafetyBridge modules without safety logic (e.g., IB IL 24 PSDI 8-PAC, IB IL 24 PSDO...-PAC). The module with integrated safety logic is referred to as the island node, while the modules without safety logic are referred to as remote devices or satellites. Satellite is the preferred term to describe these modules and is used in this document.

The satellites and the IB IL 24 LPSDO 8 V2-PAC are assigned to an island using island numbers that are specified in the parameterization tool. The satellites are numbered in the order they are assigned in SAFECNF.

A 2.2 Network and controller requirements

The SafetyBridge system does not place any special requirements on the standard controller. However, it must be able to perform the following tasks:

Network:

- Deterministic network; pauses caused by sporadic errors must not exceed the watchdog time set for the module

Controller:

- Fast enough that it can meet time expectations for the response time
- Sufficient memory to save configuration and parameter data records
- Ensuring data consistency when copying data
Data consistency must at least be ensured using the data telegram of a module.



Function blocks for copying data and downloading the configuration are available for selected controllers.

A 2.3 Safe input and output devices

Safe input and output devices form the interface to connected I/O devices. The devices control contactors or valves, for example, and/or read the input status of connected safety-related sensors.

The internal structure of the devices enables component failures, interruptions in transmission or the absence of data to be detected and reported immediately.

Even errors in the wiring or internal device errors can be detected. Errors are indicated via the process image of the devices, the function blocks, and the device LEDs. They can be evaluated by the user.

The safe I/O devices are from the Inline product range. Their design and interfaces correspond to standard Inline I/O devices. This means that no additional installation effort is required.

The devices are parameterized using the SAFECNF software according to the safety function that is to be performed. The parameterization and wiring of the inputs and outputs depends on the application (e.g., single-channel or two-channel). For more detailed information about the parameterization options, please refer to the user manual for the relevant device. The wiring and parameterization of devices determines which errors are detected.

A 3 SafetyBridge address assignment



NOTE: Malfunction in the event of incorrect addressing

Make sure that in an overall system comprising the SafetyBridge system and any higher-level PROFIsafe system, the addresses (address within the SafetyBridge system and F-Address of the PROFIsafe system) are unique. Duplicate address assignment is not permitted.

The SafetyBridge address of the IB IL 24 LPSDO 8 V2-PAC is the same as the island number of the module.

The SafetyBridge address of a satellite comprises the island number and the position in the bus navigator of the SAFECNF software tool.

Enter the address for the IB IL 24 LPSDO 8 V2-PAC in SAFECNF.

Table A-2 SafetyBridge address IB IL 24 LPSDO 8 V2-PAC

SafetyBridge address							
Island number					Reserved		
7	6	5	4	3	2	1	0
1_{dec} to 31_{dec}					0_{dec}		

Table A-3 SafetyBridge address, e.g., IB IL 24 PSDI 8-PAC

SafetyBridge address							
Island number					Satellite number		
7	6	5	4	3	2	1	0
1_{dec} to 31_{dec}					1_{dec} to 5_{dec}		

Example:

Table A-4 Example 1: SafetyBridge addresses

	Island number					Satellite number			SafetyBridge address
	7	6	5	4	3	2	1	0	
IB IL 24 LPSDO 8 V2-PAC	1_{dec}					0_{dec}			8_{dec} (8_{hex})
	0	0	0	0	1	0	0	0	
IB IL 24 PSDI 8-PAC Position 1	1_{dec}					1_{dec}			9_{dec} (9_{hex})
	0	0	0	0	1	0	0	1	
IB IL 24 PSDO...-PAC Position 2	1_{dec}					2_{dec}			10_{dec} (A_{hex})
	0	0	0	0	1	0	1	0	

Table A-5 Example 2: SafetyBridge addresses

	Island number					Satellite number			SafetyBridge address
	7	6	5	4	3	2	1	0	
IB IL 24 LPSDO 8 V2-PAC	16 _{dec} (10 _{hex})					0 _{dec}			128 _{dec} (80 _{hex})
	1	0	0	0	0	0	0	0	
IB IL 24 PSDOR 4-PAC Position 1	16 _{dec} (10 _{hex})					3 _{dec}			129 _{dec} (81 _{hex})
	1	0	0	0	0	0	0	1	
IB IL 24 PSDI 8-PAC Position 2	16 _{dec} (10 _{hex})					3 _{dec}			130 _{dec} (82 _{hex})
	1	0	0	0	0	0	1	0	
IB IL 24 PSDO 4/4-PAC Position 3	16 _{dec} (10 _{hex})					3 _{dec}			131 _{dec} (83 _{hex})
	1	0	0	0	0	0	1	1	
IB IL 24 PSDO 8-PAC Position 4	16 _{dec} (10 _{hex})					5 _{dec}			132 _{dec} (84 _{hex})
	1	0	0	0	0	1	0	0	
IB IL 24 PSDI 8-PAC Position 5	16 _{dec} (10 _{hex})					5 _{dec}			133 _{dec} (85 _{hex})
	1	0	0	0	0	1	0	1	

Table A-6 Example addresses for SafetyBridge islands

Addresses for island number 1 (red in Figure A-2)	Addresses for island number 2 (green in Figure A-2)	Addresses for island number 3 (blue in Figure A-2)	Devices
00001 000 (08 _{hex})	00010 000 (10 _{hex})	00011 000 (18 _{hex})	IB IL 24 LPSDO 8 V2-PAC (island node)
00001 001 (09 _{hex})	00010 001 (11 _{hex})		Assigned IB IL 24 PSDI 8-PAC/IB IL 24 PSDO...-PAC in SafetyBridge mode
00001 010 (0A _{hex})	00010 010 (12 _{hex})		Assigned IB IL 24 PSDI 8-PAC/IB IL 24 PSDO...-PAC in SafetyBridge mode
00001 011 (0B _{hex})	00010 011 (13 _{hex})		Assigned IB IL 24 PSDI 8-PAC/IB IL 24 PSDO...-PAC in SafetyBridge mode
00001 100 (0C _{hex})	00010 100 (14 _{hex})		Assigned IB IL 24 PSDI 8-PAC/IB IL 24 PSDO...-PAC in SafetyBridge mode
00001 101 (0D _{hex})	00010 101 (15 _{hex})		Assigned IB IL 24 PSDI 8-PAC/IB IL 24 PSDO...-PAC in SafetyBridge mode
		00011 111 (1F _{hex})	Assigned IB IL 24 PSDI 8-PAC in SafetyBridge multiplexer mode

In SafetyBridge multiplexer mode, the IB IL 24 LPSDO 8 V2-PAC is always assigned one IB IL 24 PSDI 8-PAC with the address xxxxx111 (xxxxx = island number). The IB IL 24 LPSDO 8 V2-PAC and IB IL 24 PSDI 8-PAC modules operate with a fixed parameterization.

To differentiate between SafetyBridge and SafetyBridge multiplexer mode, in SafetyBridge mode the address with "111" in the last three bits is not used. If an address with the format xxxxx111 is specified in SafetyBridge mode, the module enters the safe state.

Therefore, in SafetyBridge multiplexer mode, the address xxxxx111 set on the IB IL 24 PSDI 8-PAC corresponds to the setting for SafetyBridge multiplexer mode and the island number on the IB IL 24 LPSDO 8 V2-PAC.

IB IL 24 LPSDO 8 V2-PAC

A 4 Operating modes and setting the DIP switches in the SafetyBridge system

A 4.1 Module switch positions



For more detailed information about the function of the DIP switches, please refer to "Setting the DIP switches" on page 4-2.

The following tables show the settings on the IB IL 24 LPSDO 8 V2-PAC, IB IL 24 PSDI 8-PAC, and IB IL 24 PSDO...-PAC for operation in a SafetyBridge system.

Table A-7 IB IL 24 LPSDO 8 V2-PAC switch position

IB IL 24 LPSDO 8 V2-PAC						
DIP switches for address				Mode	500 KBD/ 2 MBD	Operating mode
9	8	7 ... 3	2 ... 0			
		Address: 31 addresses (see below)				
Off	Reserved (must be off)	Island number	Must be 0 (off)	Off (Mode1)	500 KBD or 2 MBD	SafetyBridge 16 words
				On (Mode2)		SafetyBridge 24 words
On				No function		SafetyBridge multiplexer 8 words

The following 31 addresses are available for the IB IL 24 LPSDO 8 V2-PAC:
 08_{hex} , 10_{hex} , 18_{hex} , 20_{hex} , 28_{hex} ... 90_{hex} , 98_{hex} , $A0_{\text{hex}}$, $A8_{\text{hex}}$, $B0_{\text{hex}}$, $B8_{\text{hex}}$... $F0_{\text{hex}}$, $F8_{\text{hex}}$.

Table A-8 Switch position of the satellites in SafetyBridge and SafetyBridge multiplexer mode

Satellites						
DIP switches for address				Mode	500 KBD/ 2 MBD	Operating mode
9	8	7 ... 3	2 ... 0			
Off	Off	Island number	Satellite number 1 ... 5	On (Mode 2)	500 KBD or 2 MBD	SafetyBridge, parameterization by IB IL 24 LPSDO 8 V2-PAC
Off	Off	Island number	Satellite number 7	On (Mode 2)		SafetyBridge multiplexer, parameterization by IB IL 24 LPSDO 8 V2-PAC (only for satellites with inputs)

For the SafetyBridge system, no other switch positions are permitted on the satellites.



Only use devices with a uniform transmission speed within an Inline station (a local bus). It is not possible to operate a mixture of devices with different transmission speeds.

A 4.2 SafetyBridge multiplexer mode

In this operating mode, the input data of a IB IL 24 PSDI 8-PAC safe input module is output one-to-one to the output terminals of the IB IL 24 LPSDO 8 V2-PAC. A controller is still required as this copies the data (see also Figure A-5 "I/O image and data flow in multiplexer mode" on page A-16).

The IB IL 24 LPSDO 8 V2-PAC and IB IL 24 PSDI 8-PAC which are to operate together in multiplexer mode are configured and assigned to one another via the switch position of the DIP switches (see "Setting the DIP switches" on page 4-2). The parameterizations of both modules are fixed and cannot be modified. A parameterization tool is not required for this operating mode.



Multiplexer mode is intended as a replacement for cabling. A stand-alone solution (one using MUX modules, for example) cannot be implemented with multiplexer mode.



NOTE: Not a safe application

In order to ensure correct use, subsequent safety logic (an evaluation unit) is required.

The IB IL 24 LPSDO 8 V2-PAC parameterizes both the local safe I/O devices and the input module as follows:

Table A-9 Parameterization of **all** safe outputs of the IB IL 24 LPSDO 8 V2-PAC

Parameterization	Parameterized as	Remark
Assignment	Assigned	The parameterization is set automatically and cannot be changed.
Output	Single-channel	
Switch-off delay for stop category 1	Disabled	
Value of switch-off delay for stop category 1	–	
Value range of switch-off delay for stop category 1	–	
Test pulses (output disabled) (in software: test impulses (output switched off))	Enabled	
Enable	Disabled	

The watchdog time (t_{FWD}) is set to a fixed value of 200 ms.

IB IL 24 LPSDO 8 V2-PAC

Table A-10 Parameterization of **all** safe inputs of the IB IL 24 PSDI 8-PAC

Parameterization	Parameterized as	Remark
Input		
Assignment	Assigned	The parameterization is set automatically and cannot be changed.
Evaluation	Single-channel	
Sensor type	Standard sensor	
Filter time (t_{Filter})	5 ms	
Symmetry	Disabled	
Clock selection	UT1 for inputs of channel 1 UT2 for inputs of channel 2	
Bounce time monitoring	Disabled	
Start inhibit due to symmetry violation	Disabled	
Input signal	Equivalent	
Clock output		
	UT1 ON/UT2 ON	

Example application

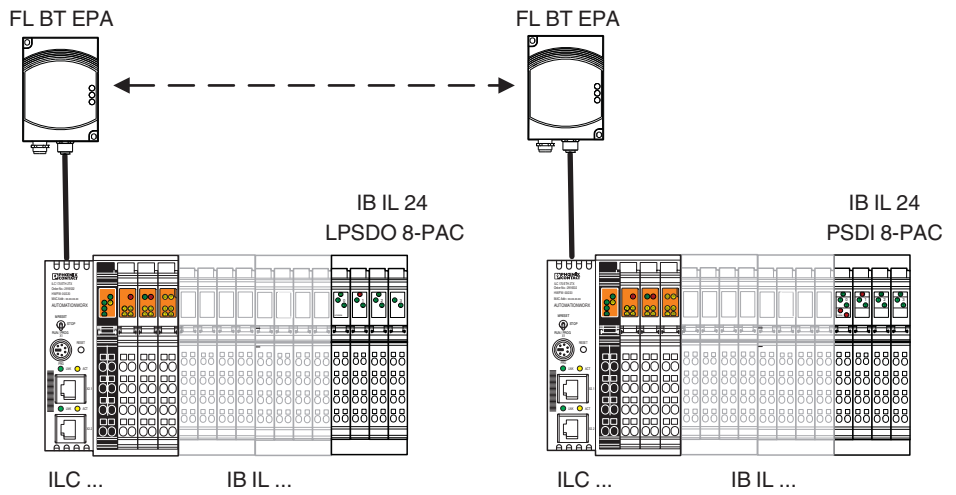

Figure A-3 Example

- ILC ... Standard controller
- IB IL ... Inline terminals according to your requirements
- FL BT EPA Bluetooth Ethernet port adapter

A 5 Process image

A 5.1 Structure of the process image

Table A-11 Key for Figure A-4

Designation	Meaning	Explanation
PII	Process image of inputs	
PIO	Process image of outputs	
SATx	Satellite x (x = 1 ... 3)	
PSDI	IB IL 24 PSDI 8-PAC	
PSDO	IB IL 24 PSDO...-PAC	
8	Number of bytes to be transmitted	
Prot-x	Protocol data	On page A-17
Short Protocol	Short protocol	On page A-20
Dev-Ack-x	Acknowledgment of device and communication errors affecting satellite x x (x = 1 ... 3)	On page A-17
Read-only parts for the standard controller (bold in PAE)		
Dev-Diag-x	Diagnostic data of satellite x (x = 1 ... 3)	On page A-17
Data-x	Safe data of satellite x (x = 1 ... 3)	On page A-17
Dev-Diag-LPSDO	Diagnostic data of all modules	On page A-19
App-Diag-LPSDO	Freely configurable feedback signals of the IB IL 24 LPSDO 8 V2-PAC to the standard controller	On page A-19
Feedback-Data-PSDO	Safe output data of the IB IL 24 PSDO...-PAC read back automatically	On page A-20
Feedback-Data-LPSDO	Safe output data of the IB IL 24 LPSDO 8 V2-PAC read back automatically	On page A-20
Read/write parts for the standard controller (bold in PIO)		
Dev-Ack-LPSDO	Acknowledgment of device and communication errors affecting the IB IL 24 LPSDO 8 V2-PAC	On page A-19
App-Ack-LPSDO	Freely configurable acknowledgment signals of the standard controller to the IB IL 24 LPSDO 8 V2-PAC	On page A-20
Enable-PSDO	Standard data of the standard controller, which is to enable the IB IL 24 PSDO...-PAC	On page A-20
Enable-LPSDO	Standard data of the standard controller, which is to enable the IB IL 24 LPSDO 8 V2-PAC	On page A-20

Figure A-4 shows an example of the structure of the I/O image and data flow for the 16-word-wide version of the IB IL 24 LPSDO 8 V2-PAC with 3 satellites (2 x IB IL 24 PSDI 8-PAC, 1 x IB IL 24 PSDO...-PAC). For an explanation of the data flow, please refer to Section A 6, "Implementation of data flow between the standard controller and the safety modules" on page A-22.

IB IL 24 LPSDO 8 V2-PAC

If a SafetyBridge island is made up of a different constellation, the following rules apply for mapping the individual submodules within the IB IL 24 LPSDO 8 V2-PAC:

- The sequence of the satellites within the IB IL 24 LPSDO 8 V2-PAC must be determined by the satellite numbers.
- The corresponding SafetyBridge addresses within an island are in ascending order and without gaps.

Figure A-5 shows an example of the structure of the I/O image and data flow for multiplexer mode.

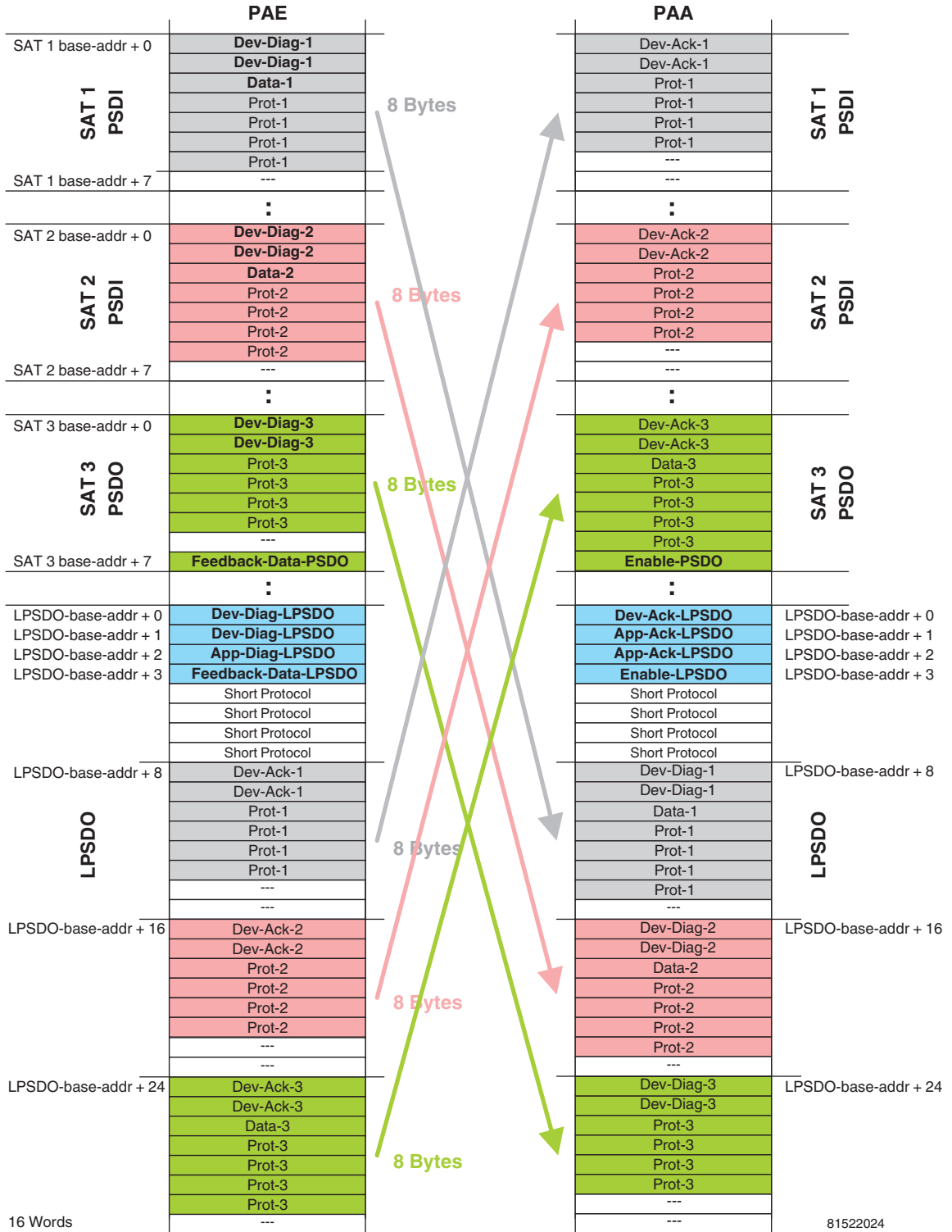

Figure A-4 I/O image and data flow in a system comprising 1 IB IL 24 LPSDO 8 V2-PAC and 3 satellites

IB IL 24 LPSDO 8 V2-PAC

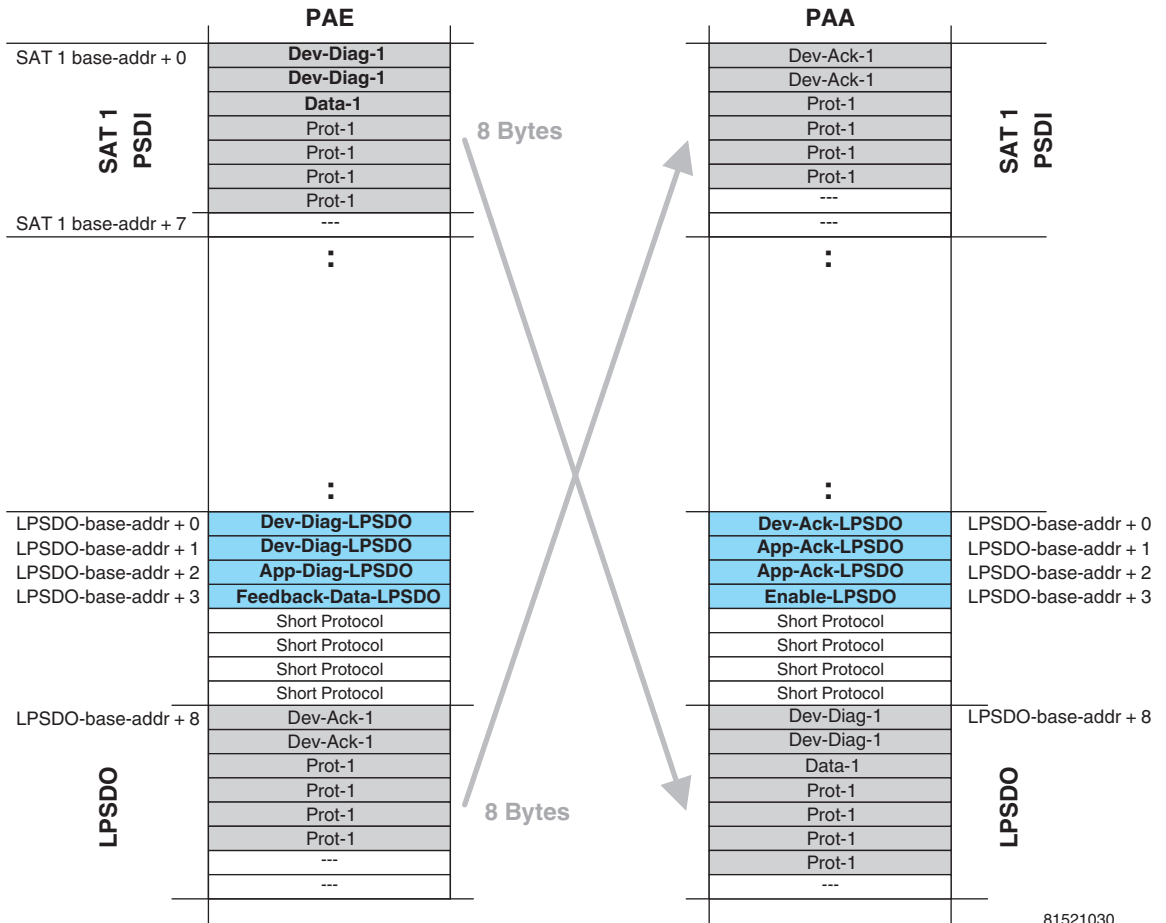

Figure A-5 I/O image and data flow in multiplexer mode

81521030

A 5.2 Description of the registers



The register assignment for the IB IL 24 LPSDO 8 V2-PAC, IB IL 24 PSDI 8-PAC, and IB IL 24 PSDO 8-PAC is illustrated below.

As the registers are device-specific, the assignment for other modules may differ from the description. Check the register assignment against the device-specific documentation.

The actual assignment of the data registers (Data..., Feedback-Data...) is determined by the parameterization (single-channel, two-channel). The register description below describes all bits. Please refer to the description of the process data words in the documentation for the modules for information about which bits are actually assigned.

Data-x (safe data of satellite x)

The register contains the safe data of the specified satellite. The structure and function of the register are as follows:

Table A-12 Data-x register

	7	6	5	4	3	2	1	0
IB IL 24 PSDI 8-PAC	IN3 _Ch2	IN3 _Ch1	IN2 _Ch2	IN2 _Ch1	IN1 _Ch2	IN1 _Ch1	IN0 _Ch2	IN0 _Ch1
IB IL 24 PSDO...-PAC	OUT3 _Ch2	OUT3 _Ch1	OUT2 _Ch2	OUT2 _Ch1	OUT1 _Ch2	OUT1 _Ch1	OUT0 _Ch2	OUT0 _Ch1



The data is only valid as long as the connection is active.

Prot-x

Protocol data; the user cannot access this register.

Dev-Diag-x (PSDI, PSDO diagnostics)

The diagnostic register of the specified (x) IB IL 24 PSDI 8-PAC or IB IL 24 PSDO...-PAC has the following structure and function:

Table A-13 Dev-Diag register of the IB IL 24 PSDI 8-PAC or IB IL 24 PSDO...-PAC

15	14	13	12	11	10	...	0
Diag-Sel			Diagnostic code/address				

Bit	Meaning		Function
15 ... 13	Diag- Sel	Diagnostic selector	111 _{bin} : Bit 12 has no function. Bits 11 ... 0 contain the diagnostic code of the module. Please refer to the user manual for the satellites you are using for information about the function of the diagnostic codes.
			100 _{bin} : No errors (8000 _{hex})
			010 _{bin} : Bits 12 ... 0 contain the address of the module.
			Others: Reserved

Dev-Ack-x (device acknowledgment)

This register is used to acknowledge device errors internally. The user cannot access this register.

IB IL 24 LPSDO 8 V2-PAC

Dev-Diag-LPSDO (LPSDO diagnostics)

The diagnostic register of the IB IL 24 LPSDO 8 V2-PAC has the following structure and function:

Table A-14 Dev-Diag register of the IB IL 24 LPSDO 8 V2-PAC

15	14	13	12	11	10	...	0
COK	SA	E	PUR	OAR	Diagnostic code/address		

Bit		Meaning	Function
15	COK	Communication OK	0: IB IL 24 LPSDO 8 V2-PAC is not parameterized or at least one of the safe communication relationships is not running without any errors.
			1: Communication OK IB IL 24 LPSDO 8 V2-PAC is parameterized and safe communication is running without any errors to all configured satellites. If no satellites have been configured: IB IL 24 LPSDO 8 V2-PAC is parameterized.
14	SA	Safety address	0: The error message of the IB IL 24 LPSDO 8 V2-PAC is displayed in bits 10 ... 0 together with the error class, number, and location (see "Errors: Messages and removal" on page 8-1).
			1: Firmware startup after power up completed. The SafetyBridge address setting is displayed in bits 10 ... 0.
13	E	Device error	0: No error messages pending at any modules.
			1: Group error message: A device error, a parameterization error, or an I/O error has been detected in one of the connected satellites or in the IB IL 24 LPSDO 8 V2-PAC itself. This can be detected via the corresponding Dev-Diag registers of the individual satellites.
12	PUR	Power up requested	0: A power up is not expected.
			1: Following an error that cannot be acknowledged, the IB IL 24 LPSDO 8 V2-PAC or one of the satellites expects a power up.
11	OAR	Operator acknowledge requested	0: No request for acknowledgment.
			1: The IB IL 24 LPSDO 8 V2-PAC requests an acknowledgment by the user. Previously: SafetyBridge communication detected an acknowledgeable error resulting in communication being deactivated.
Bits 10 ... 0		Diagnostic code/address	Bit 14 = 0: The error message of the IB IL 24 LPSDO 8 V2-PAC is displayed in bits 10 ... 0 together with the error class, number, and location (see "Errors: Messages and removal" on page 8-1).
			Bit 14 = 1: The error message of the SafetyBridge address setting is displayed in bits 10 ... 0.



OAR:

If safe communication is not running to one or more satellites, the OAR bit can indicate that communication can be restored. The user restores communication by means of a positive edge at the OA bit in Dev-Ack-LPSDO.

A positive edge at the OA flag acknowledges **all** currently pending operator acknowledge requests from **all** satellites.

**WARNING: Unexpected machine startup**

If you do not want the machine to start up/restart automatically, configure the safety logic accordingly.

**Dev-Ack-LPSDO
(acknowledgment)**

The register for acknowledging the IB IL 24 LPSDO 8 V2-PAC has the following structure and function:

Table A-15 Dev-Ack register of the IB IL 24 LPSDO 8 V2-PAC

7	6	5	4	3	2	1	0
OA	S	QE5	QE4	QE3	QE2	QE1	QE0

Bit		Meaning	Function
7	OA	Operator acknowledge	0 -> 1: Acknowledgment of error message regarding failsafe communication (see also OAR bit in Dev-Diag register).
6	S	Start LPSDO	0 -> 1: Start of the project saved on the IB IL 24 LPSDO 8 V2-PAC.
5 ... 1	QE 5 ... 1	Quit error device 5 ... 1	0 -> 1: Acknowledgment of satellite error (satellite 5 to 1) by the user. If another error is present on the corresponding module, it is displayed as the next error.
0	QE0	Quit error device IB IL 24 LPSDO 8 V2-P AC	0 -> 1: Acknowledgment of IB IL 24 LPSDO 8 V2-PAC error message by the user. If another error is present on the module, it is displayed as the next error.



OA:

A positive edge at the OA bit acknowledges **all** currently pending operator acknowledge requests from all satellites.

S:

To start a project with a quick start, proceed as follows:

1. Initialize registers 4 to 7 of the IB IL 24 LPSDO 8 V2-PAC (short protocol) with 0.
2. Set bit S to 1.
3. Write the project header CRC to registers 4 to 7 of the IB IL 24 LPSDO 8 V2-PAC.

**App-Diag-LPSDO
(application diagnostics)**

The bits in this register can be freely programmed in SAFECONF. Implement diagnostics using these bits.

The IB IL 24 LPSDO 8 V2-PAC register has the following structure and function:

Table A-16 IB IL 24 LPSDO 8 V2-PAC App-Diag-LPSDO register

	7	6	5	4	3	2	1	0
Identifier in SAFECONF	0_Q7	0_Q6	0_Q5	0_Q4	0_Q3	0_Q2	0_Q1	0_Q0
Help text in SAFECONF	App_ Diag.X7	App_ Diag.X6	App_ Diag.X5	App_ Diag.X4	App_ Diag.X3	App_ Diag.X2	App_ Diag.X1	App_ Diag.X0

IB IL 24 LPSDO 8 V2-PAC**App-Ack-LPSDO
(application
acknowledgment for
IB IL 24 LPSDO 8 V2-PAC)**

The bits in this register can be freely programmed in SAFECONF and can be used for the safety logic. Implement diagnostics using these bits.

The IB IL 24 LPSDO 8 V2-PAC register has the following structure and function:

Table A-17 IB IL 24 LPSDO 8 V2-PAC App-Ack-LPSDO register

	15	14	...	1	0
Identifier in SAFECONF	0_I15	0_I14	...	0_Q1	0_Q0
Help text in SAFECONF	App_ Ack.X15	App_ Ack.X14	...	App_ Ack.X1	App_ Ack.X0

**Feedback-Data-PSDO/
Feedback-Data-LPSDO
(mirroring)**

The bits in this register mirror the states of the digital outputs. In the event of an error, the mirrored data can differ from the actual state of the outputs. This data is, therefore, only provided as diagnostic information and must not be used as standard data. The structure and function of the register are as follows:

Table A-18 Feedback-Data register (mirrored data)

7	6	5	4	3	2	1	0
OUT3 _Ch2	OUT3 _Ch1	OUT2 _Ch2	OUT2 _Ch1	OUT1 _Ch2	OUT1 _Ch1	OUT0 _Ch2	OUT0 _Ch1

**Enable-PSDO,
Enable-LPSDO
(data of the standard
controller for the enable
function)**

The register contains standard data of the standard controller, which is to enable the IB IL 24 LPSDO 8 V2-PAC or the IB IL 24 PSDO...-PAC. Each bit is assigned to a specific output. The structure and function of the register are as follows:

Table A-19 Enable-PSDO/Enable-LPSDO register

7	6	5	4	3	2	1	0
OUT3 _Ch2	OUT3 _Ch1	OUT2 _Ch2	OUT2 _Ch1	OUT1 _Ch2	OUT1 _Ch1	OUT0 _Ch2	OUT0 _Ch1

Short protocol

The short protocol is assigned as follows:

Table 10-2 Short protocol assignment

Byte	Meaning	Description
1	Index	Object index to be accessed
2	Offset (low)	Start offset within the object (low)
3	Offset (high)	Start offset within the object (high)
4	Data	Value (dependent upon object index)

Table 10-3 Possible indices in the short protocol

Index [hex]	Meaning	Note
11	Project header saved in the IB IL 24 LPSDO 8 V2-PAC	Read-only, uses short protocol
90	IB IL 24 LPSDO 8 V2-PAC status	Read-only
91	Loading and starting of the project header	Write-only, uses short protocol
92	Address block	Write-only, uses short and long protocol
93	Logic block	Write-only, uses short and long protocol
94	Deletion of the project saved in the IB IL 24 LPSDO 8 V2-PAC	Write-only, uses short protocol

A 6 Implementation of data flow between the standard controller and the safety modules

For the parallel communication required between safe components, data flow must be ensured by the relevant standard controller. Consistency must, therefore, be ensured over the entire data width of the safe devices.



If data consistency is not ensured, the module shuts down and requests an operator acknowledgment.

Data flow within standard infrastructure components is not safety-related. The measures for safeguarding failsafe communication are implemented in the safe termination devices.

A 6.1 Implementation of data flow with a function block

A copy function block (COPY FB) to safeguard data flow between the SafetyBridge modules is available from Phoenix Contact for certain systems.

A 6.2 Implementation of data flow without a function block

If a function block (COPY FB) is not available for your controller, you must implement data flow within the SafetyBridge system yourself.

The SafetyBridge components are represented in the process image of the higher-level controller with a special I/O structure. The structure is mapped in the corresponding device description.

The components illustrated in Figure A-4 must be copied according to the arrows for the data flow required between the SafetyBridge components. The data/registers in bold are also useful for the standard application program of the standard controller.

A 7 Enable principle

The enable principle is implemented in the SafetyBridge system. For this, all modules with local outputs have an enable function integrated in the device firmware (ANDed bit-by-bit) for each local safe output channel. The enable function can be parameterized (enabled/disabled) for each specific channel.

When the enable function is enabled, the relevant safe local output is ANDed bit-by-bit with the corresponding standard output of the standard controller (Data-LPSDO register). This output is then only set if the result of the safety function calculation permits this and the standard controller has set the corresponding output in the Data-LPSDO register (see also "I/O image and data flow in a system comprising 1 IB IL 24 LPSDO 8 V2-PAC and 3 satellites" on page A-15).

The enable function is performed according to the single-channel or two-channel parameterization of the safe outputs.

The enable function cannot be used in multiplexer mode.



The enable function is not graphically represented in SAFECONF in the safety logic editor. Parameterize the enable function when parameterizing the channels.

The following figure illustrates the enable principle.

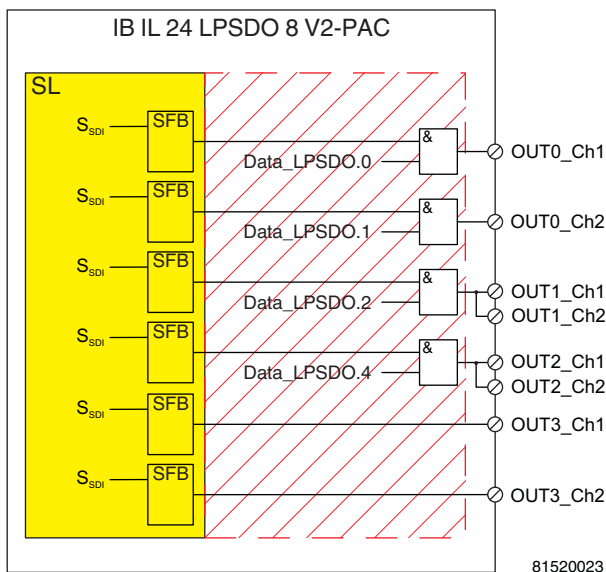

Figure A-6 Enable principle (example)

- SL Safety logic
- SFB Safe function block
- & Standard function block for ANDing
- SSDI Signal from the IB IL 24 PSDI 8-PAC safe input module
- Data-LPSDO.x Standard data of the standard control system, which is to enable the IB IL 24 LPSDO 8 V2-PAC; bit x
- OUTx_Ch_y Output x, channel y
- Internal sequences

Table A-20 Parameterization of output channels for the example in Figure A-6

Output/Channel	Output	Enable
OUT0_Ch1	Single-channel	Enabled
OUT0_Ch2	Single-channel	Enabled
OUT1_Ch1	Two-channel	Enabled
OUT1_Ch2	Two-channel	Enabled
OUT2_Ch1	Two-channel	Enabled
OUT2_Ch2	Two-channel	Enabled
OUT3_Ch1	Single-channel	Disabled
OUT3_Ch2	Single-channel	Disabled

A 8 Diagnostics

In addition to precise diagnostics for the standard bus system, the safe input and output devices also support the detection of I/O errors and device errors.

A 8.1 Error detection in I/O devices

Safe inputs

Depending on the device type and parameterization, the following errors can be detected at safe inputs:

- Short circuit
- Cross circuit
- Overload/short circuit of the clock outputs

When an error is detected at an input, the safe state is set for this input and a "0" is transmitted in the input data of the input ("0" = safe state).

The corresponding error message is transmitted to the IB IL 24 LPSDO 8 V2-PAC and the standard controller.



For more detailed information about error detection at safe inputs, please refer to the user manual for the IB IL 24 PSDI 8-PAC.

Safe outputs

Depending on the device type and parameterization, the following errors can be detected at safe outputs:

- Short circuit
- Cross circuit
- Overload
- Violation of the shutdown time

When an error is detected at an output, the affected output is disabled ("0" = OFF = safe state).

The corresponding error message is transmitted to the IB IL 24 LPSDO 8 V2-PAC and the standard controller.



For more detailed information about error detection at safe outputs, please refer to the user manual for the IB IL 24 PSDO...-PAC modules.

A 8.2 Detection of device errors

All serious errors that can result in the loss of or adversely affect the safety function cause the entire device to enter the safe state. The FS LED on the safe device is permanently on.

Depending on the device type, the following errors lead to the safe state:

- Hardware fault in the circuit
- User error
- Module overload
- Overheating
- Faulty supply voltage

The corresponding error message is transmitted to the IB IL 24 LPSDO 8 V2-PAC and the standard controller.



To determine which errors are detected by a specific device, please refer to the corresponding device documentation.

A 8.3 Acknowledgment of error messages for satellites

Errors that occur on satellites are acknowledged by the standard controller in the Dev-Ack-LPSDO register on the IB IL 24 LPSDO 8 V2-PAC (see "Description of the registers" on page A-17). The acknowledgment is forwarded to the satellites.



An example for the acknowledgment of error messages can be found in the quick start guide for the IB IL 24 LPSDO 8 V2-PAC (see "Ordering data: Documentation" on page 10-7).

A 9 Configuration, parameterization, and download



An example for configuration, parameterization, and download can be found in the quick start guide for the IB IL 24 LPSDO 8 V2-PAC (see "Ordering data: Documentation" on page 10-7).

A 9.1 Configuration and parameterization using the SAFECNF tool

The SAFECNF software tool is available to users for configuring the safety logic and parameterizing the channels of the safety modules used. Configuration and parameterization can be carried out offline, without connecting to the safety modules.

Configuration

During configuration, you select the modules, set the switches, and connect the safety function in SAFECNF.

Parameterization

To parameterize the system, parameterize each input and output of the system. You must also set the watchdog time for each satellite.

Configuration and parameter data record

The safe configuration and parameterization user interface of SAFECNF generates a data record containing the configuration and parameterization data of all modules of a SafetyBridge island in the format specific to the controller. So that data consistency and uniqueness can be checked, suitable means such as addresses, module IDs, and CRCs are included in the configuration and parameter record.

Import this configuration and parameter data record into the standard controller used according to the controller.

On every power up, make this data record available to the IB IL 24 LPSDO 8 V2-PAC island node (see "Downloading the configuration and parameter data record following power up" on page A-27). The IB IL 24 LPSDO 8 V2-PAC module is thus parameterized. The satellites are parameterized automatically by the IB IL 24 LPSDO 8 V2-PAC module.

SAFECNF can be used as a stand-alone tool. However, depending on the control system, calling SAFECNF can also integrate the transfer of the configuration and parameter record deeper into the relevant control system.



Online help is available for the SAFECNF software tool.



SAFECNF should also be used in the planning phase. If the size of the configuration and parameter data record for the planned safety functions exceeds the memory size, an error message is displayed and changes can be made at an early stage.

To roughly estimate the memory required, please use the information in "Memory sizes for the safety logic" on page A-33.

A 9.2 Downloading the configuration and parameter data record following power up

The entire configuration and parameterization can be created offline with SAFECNF. A fully installed system is not required until the download stage. Communication must be running when transmitting the data record.



WARNING: Loss of safety function

Before downloading a data record, check whether the current data record is actually loaded.

Make sure that you do not overwrite the data record on the IB IL 24 LPSDO 8 V2-PAC with an old data record. Information about a data record is provided in the project header.

During startup, do not configure a delete service for a configuration and parameter data record. Before overwriting a data record, always read back the project header first.



Make sure that you are sending the correct data record to the correct IB IL 24 LPSDO 8 V2-PAC. If a data record is sent to a IB IL 24 LPSDO 8 V2-PAC for which it was not intended, an error message is displayed in the diagnostic register of the IB IL 24 LPSDO 8 V2-PAC.



Function blocks can be downloaded for selected controllers.

A 10 Safe state

The safe state

- For safe output devices, the safe state is the power off state at the affected output terminals
- For safe input devices, the safe state is the transmission of the "safe state value" ("0") in the image of the affected inputs to the safe standard control system
- For transmission on the bus, the safe state is the transmission of the value "0"

The safe state can be a normal operating state or is set if a corresponding error has been detected.

A 11 Time response in the SafetyBridge system

In the planning phase of the machine/system and the SafetyBridge system, specify the required shutdown time for each safety function. This is ascertained on the basis of the safety evaluation of the machine/system, taking into consideration the safety distances and the approach speed. Observe the applicable standards and regulations.

In the planning phase of the planned SafetyBridge system, also calculate the shutdown time for the outputs.

Then, for each safety function, check whether, in conjunction with all other components, the calculated shutdown time is sufficient to ensure compliance with the required shutdown time for the safety function.

The aim of the calculations is to ensure that the safety function responds within the required time.

A 11.1 Typical response time

The typical response time of the SafetyBridge system is the time that elapses from the signal being applied at the safe input terminal through to the response at the safe output terminal. This time can usually only be achieved and measured during error-free operation of the SafetyBridge system.

The typical response time of the SafetyBridge system is not relevant and not suitable for dimensioning safety distances.

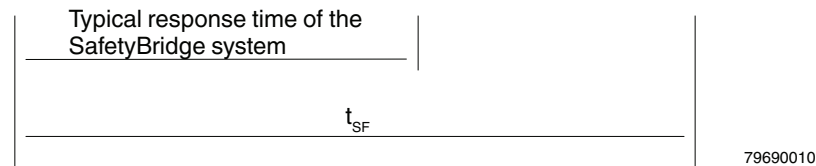

Figure A-7 Typical response time and required shutdown time for the safety function

Table A-21 Key for formula and Figure A-8

Abbreviation	Meaning	Note
t_{SF}	Required shutdown time for the safety function	Determined from the application, e.g., from the required times according to the distance of a light grid



The typical response time depends on the network and standard controller used.

A 11.2 Shutdown times

The **required** shutdown time for the safety function is based on the response times of the sensors used, the SafetyBridge system, the actuator used, and the stopping time of the system. The required shutdown time of the safety function can be determined from the safety distances or the safety distances are defined based on the determined guaranteed shutdown time.

The **guaranteed** shutdown time for the safety function is based on the longest processing time of the safe inputs involved in the safety function and the shutdown time of the safe output (single-channel or two-channel) involved.

For the processing time of the safe inputs, please refer to the corresponding data sheets for the safe input devices.

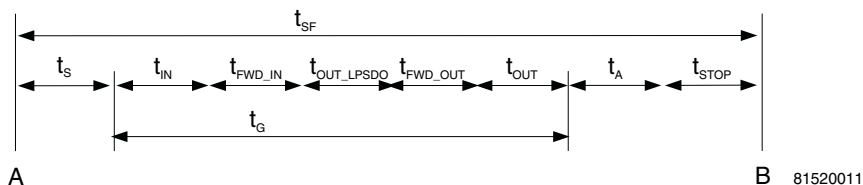

Figure A-8 Overview of shutdown times

This results in the following formula for t_{SF}

$$t_{SF} = t_S + t_{IN} + t_{FWD_IN} + t_{OUT_LPSDO} + t_{FWD_OUT} + t_{OUT} + t_A + t_{STOP}$$

Table A-22 Key for formula and Figure A-8

Abbreviation	Meaning	Note
A	Demand of the safety function	
B	Safe state of the system	
t_{SF}	Required shutdown time for the safety function	Determined from the application, e.g., from the required times according to the distance of a light grid
t_S	Response time of the sensor	Sensor data sheet
t_{IN}	Processing time of the input	Safe input module user manual
t_{FWD_IN}	F-Watchdog time (communication)	Specified by the user in SAFECONF for each IB IL 24 PSDI 8-PAC module
t_{OUT_LPSDO}	Shutdown time of the IB IL 24 LPSDO 8 V2-PAC	10 ms; see technical data "SafetyBridge system" on page 10-1
t_{FWD_OUT}	F-Watchdog time (communication)	Specified by the user in SAFECONF for each IB IL 24 PSDO...-PAC module Without forwarding to a satellite with outputs, $t_{FWD_OUT} = 0$.
t_{OUT}	Shutdown time of the output	Safe output module user manual Without forwarding to a satellite with outputs, $t_{OUT} = 0$.

IB IL 24 LPSDO 8 V2-PAC

Table A-22 Key for formula and Figure A-8

Abbreviation	Meaning	Note
t_A	Response time of the actuator	Actuator data sheet
t_{STOP}	Stopping time of the machine	Measurement
t_G	Guaranteed shutdown time	Calculation: $t_G = t_{IN} + t_{FWD} + t_{OUT_LPSDO}$



Fluctuations in network communication and in the copy routines (e.g., including controller STOP) result in safe communication being aborted.

 t_{FWD}

The F-Watchdog time (t_{FWD}) is specified for each communication relationship in SAFECNF.

The minimum achievable t_{FWD} depends on the network and the controller (see documentation for the controller used).



When specifying the F-Watchdog time, please remember that it can be affected by future system expansions.

Within t_{FWD} , the standard network and the standard controller must be able to transmit telegrams from satellite to the IB IL 24 LPSDO 8 V2-PAC.

 t_s, t_{IN} 

If **several sensors** are involved in the safety function, the longest response time of the sensors involved is included in the calculation.

If **several inputs** are involved in the safety function, the longest processing time of the inputs involved is included in the calculation.

If **several IB IL 24 PSDI 8-PAC** devices are involved in a safety function, the longest F-Watchdog time is included in the calculation.

A 12 Achievable safety depending on the modules used



Phoenix Contact recommends using the SISTEMA software utility to determine achievable safety.

The SISTEMA software utility for the safety of control systems on machines can be downloaded free of charge from the Internet site of the Institute for Occupational Safety and Health of the German Social Accident Insurance, see www.dguv.de/ifa/de/prs/softwa/sistema/index.jsp.

This Windows tool provides assistance in evaluating the safety of control systems within the scope of EN ISO 13849-1.

According to SISTEMA, performance level PL e can be achieved with the maximum configuration (IB IL 24 LPSDO 8 V2-PAC module and 5 satellites). However, you should always check your actual application to ascertain the level of safety that can be achieved.

A 13 Behavior in the event of an error

Error messages

Errors that occur on the safe devices can be detected using process data, function blocks, and device LEDs.

These error messages can be evaluated in the standard application program or can be displayed by means of a visualization.



For instructions on how to proceed in the event of an error, please refer to "Parameterization errors" on page 8-6.

Service information

In addition to error messages, service information can also be output. This information takes the form of device message warnings that do not affect the safety function. These warnings are either unacknowledged messages or messages that are acknowledged via the controller.

Error classes

The response of all devices connected to the system and the safety functions to an error depends on the error class detected.

There are 3 different error classes in the SafetyBridge system:

- Critical system and device errors
- Parameterization and configuration errors
- I/O errors

A distinction is made based on:

- The severity of the error
- The reciprocal effects on other components in the system
- The acknowledgment and restart options

Acknowledgment

The acknowledgment of an error is an intentional user action (controlled via the standard application program) with the aim of showing the system (or subsystem) that an error has been removed and that the system (or subsystem) can reactivate the faulty component.

Errors affecting a SafetyBridge island are acknowledged via the acknowledgment register of the IB IL 24 LPSDO 8 V2-PAC (see "Dev-Ack-LPSDO (acknowledgment)" on page A-19).

A 13.1 Critical system or device errors

All errors that are detected and immediately switch the device to the failure state are assigned to this class.

They include:

- Hardware faults (detected by selftests within devices)
- Parameterization and configuration data errors (detected via the CRC)
- Control flow/program sequence errors within the firmware of a device

Errors in this class are usually errors within the system, the hardware, or the firmware, which were not caused by the user and cannot be removed (device-specific exceptions are possible).

It is not possible to acknowledge the error or continue operating. The affected devices can only be restarted via a voltage reset. If the power on selftests are successful following a restart, the system can continue to operate.

A 13.2 Parameterization or configuration errors

All errors that are detected during the plausibility check of parameters and configuration data are assigned to this class. This check is usually carried out during the initialization phase of the system. Following the detection of an error in this class, the devices enter the safe state and are still able to send diagnostic information or receive new parameter or configuration data.

It is not possible to acknowledge the error or continue operating without modifying the parameter or configuration data of the affected device.

A 13.3 Communication errors

Errors detected in the safe protocol during network communication can lead to "operator acknowledge requested" (acknowledgement by the user; see "Dev-Diag-LPSDO (LPSDO diagnostics)" on page A-18). For example, these include:

- Transmission errors
- Data inconsistency when copying
- t_{FWD} setting is incorrect (the network is too slow for the t_{FWD} setting)
- Standard controller in STOP

These errors can be acknowledged. Do not acknowledge these errors from within the application program. Acknowledgment must be triggered by an intentional user action.

A 13.4 I/O errors

All errors that can occur and are detected within the I/O devices connected to the safe I/O devices are assigned to this class. For example, these include:

- Short/cross circuits at the inputs or outputs
- Other application-specific errors

These errors are usually detected in the operating phase of the system. When an error is detected, the affected input or output is disabled and a diagnostic message is sent to the IB IL 24 LPSDO 8 V2-PAC and the standard controller. The standard system remains ready for operation. Ongoing operation of the application depends on the application itself.

I/O errors can be acknowledged individually by the user in the standard application program.

A 14 Startup and restart

A 14.1 Startup/restart following power up

The module starts up once the configuration and parameterization data record has been downloaded successfully and the internal tests have been completed without errors.

**WARNING: Unexpected machine startup**

If you do not want the machine to start up/restart automatically, configure the safety logic accordingly.

A 14.2 Restart after triggering a safety function

The SafetyBridge system resets a safety-related output to "1" automatically when the safety function trigger is reset.

**WARNING: Unexpected machine startup**

If you do not want the machine to restart automatically, configure the safety logic accordingly.

A 15 Memory sizes for the safety logic

The maximum size of the safety logic is 20 kB.

The following guide values can be used as a basis for creating your safety logic:

- Size of the first instance of each block: 800 bytes
- Size of each additional instance: 300 bytes
- In the mix calculation, both of these values include a reserve for various other logic operations (AND, OR, NOT, etc.).

For the actual size of the data record, please refer to SAFECNF. If the safety logic limit has been exceeded, a corresponding error message is displayed by SAFECNF. In this case, reduce the size of your safety logic.

B Appendix: Checklists

The checklists listed in this section provide support during the planning, assembly and electrical installation, startup, parameterization, and validation of the IB IL 24 LPSDO 8 V2-PAC module.



These checklists may be used as planning documentation and/or as verification to ensure the steps in the specified phases are carried out carefully.

Archive the completed checklists to use as reference for recurring tests.

The checklists do not replace the validation, initial startup, and regular testing performed by qualified personnel.

The following section of a checklist shows an example of a completed checklist.

Checklist . . .				
Device type/equipment identification		IB IL 24 LPSDO 8 V2-PAC/BK20NA10		
Version: HW/FW/FW	00/100/100	Date	2011-03-01	
Author	John Smith	Test engineer	Jane Brown	
Remark	System XXX has been checked for engine hood production			
No	Requirement (mandatory)	Yes	Remark	
.				
X	...	<input type="checkbox"/>		
No	Requirement (optional)	Yes	No	Remark
.				
Y	...	<input type="checkbox"/>	<input type="checkbox"/>	

Key:

Equipment identification	Enter the device type and/or the equipment identification for the relevant device.
Version: HW/FW/FW	Enter the hardware and firmware version of the device (see "Structure of the safety module" on page 2-2).
Date	Enter the date on which you began to fill in this checklist.
Author/Test engineer	Enter the names of the author and the test engineer.
Remark	Enter a remark, if necessary.
Requirement (mandatory)	These requirements must be met for a safety application, in order to complete the relevant phase using the checklist.
Requirement (optional)	These requirements are optional. For points that are not met, please enter an appropriate remark in the relevant field.

IB IL 24 LPSDO 8 V2-PAC

B 1 Checklists for the SafetyBridge system**B 1.1 Planning**

Checklist for planning the use of the SafetyBridge system			
Equipment identification			
		Date	
Author		Test engineer	
Remark			
No.	Requirement (mandatory)	Yes	Remark
1	Has a hazard and risk analysis been carried out for the system/machine?	<input type="checkbox"/>	
2	Has the corresponding safety integrity level (SIL, SIL CL, Cat., PL) been derived from the hazard and risk analysis?	<input type="checkbox"/>	
3	Does the SafetyBridge system meet the required safety integrity level?	<input type="checkbox"/>	
4	Has the current IB IL 24 LPSDO 8 V2-PAC user manual been used as the basis for planning?	<input type="checkbox"/>	Revision:
5	Has the voltage supply been planned according to the specifications for the protective extra-low voltage in accordance with PELV?	<input type="checkbox"/>	
6	Are safety distances that must be observed calculated according to the response and delay times implemented?	<input type="checkbox"/>	
7	Has the required shutdown time for the safety function t_{SF} resulting from the machine/system design been determined?	<input type="checkbox"/>	t_{SF} :
8	Can the planned application be implemented with the configuration options (e.g., by using function blocks)?	<input type="checkbox"/>	
9	Does the planned use correspond to the intended use of the system?	<input type="checkbox"/>	
10	Has the technical data of the SafetyBridge system been observed?	<input type="checkbox"/>	
11	Has it been ensured that in an overall system comprising the SafetyBridge system and any higher-level PROFIsafe system, the addresses (address within the SafetyBridge system and F-Address of the PROFIsafe system) are unique?	<input type="checkbox"/>	
12	Within a SafetyBridge system, is each island number only assigned once?	<input type="checkbox"/>	
13	Is the application stop (OFF, STOP, emergency stop, triggering of safety equipment) implemented according to EN 60204?	<input type="checkbox"/>	
14	When planning the safety functions, has the SAFECONF software tool been used to determine whether the memory space is sufficient for the size of the safety logic?	<input type="checkbox"/>	
15	Has it been ensured that any person intentionally starting hazardous movements has a direct view of the danger zone?	<input type="checkbox"/>	

No.	Requirement (optional)	Yes	No	Remark
16	Are all measures that are based on applicable standards planned?	<input type="checkbox"/>	<input type="checkbox"/>	
17	Have the Inline specifications (e.g., cabling, power supply) been observed?	<input type="checkbox"/>	<input type="checkbox"/>	
18	Have the accessories to be used been planned (e.g., cables, connectors)?	<input type="checkbox"/>	<input type="checkbox"/>	
19	Is the transmission speed for the individual Inline stations specified?	<input type="checkbox"/>	<input type="checkbox"/>	
20	Are the specifications for parameterization, assembly, electrical installation, startup, and validation of the IB IL 24 LPSDO 8 V2-PAC described?	<input type="checkbox"/>	<input type="checkbox"/>	
21	Are the specifications for parameterization, assembly, electrical installation, startup, and validation of the satellites described?	<input type="checkbox"/>	<input type="checkbox"/>	
22	Is the assignment of responsibility specified (e.g., for assembly/installation/configuration, parameterization/startup/validation, etc.)?	<input type="checkbox"/>	<input type="checkbox"/>	Name/company:
23	Are measures planned which prevent hazardous states in each phase (e.g., specification of individual steps in the procedure for each phase)?	<input type="checkbox"/>	<input type="checkbox"/>	
24	Is monitoring of the actuators and sensors controlled/requested by the SafetyBridge system planned (e.g., reading of outputs)?	<input type="checkbox"/>	<input type="checkbox"/>	
		Date		Signature (author)
		Date		Signature (test engineer)

IB IL 24 LPSDO 8 V2-PAC

B 1.2 Configuration and parameterization

Checklist for configuration and parameterization of the SafetyBridge system				
Equipment identification				
		Date		
Author		Test engineer		
Remark				
No.	Requirement (mandatory)	Yes	Remark	
1	Has the safety logic been configured?	<input type="checkbox"/>		
2	Have all inputs and outputs been fully and correctly parameterized?	<input type="checkbox"/>		
3	Are standard input signals exclusively used to configure standard operations (e.g., for the enable principle using the EN_OUT block or for acknowledgment)?	<input type="checkbox"/>		
4	Has it been ensured that in the overall system comprising SafetyBridge and any higher-level PROFIsafe system, the addresses (address within the SafetyBridge system and F-Address of the PROFIsafe system) are unique?	<input type="checkbox"/>		
5	Has watchdog time t_{FWD} been set for each satellite according to the application?	<input type="checkbox"/>		
6	Has the correct terminal point been assigned to the correct signal?	<input type="checkbox"/>		
7	Is the island address set correctly?	<input type="checkbox"/>		
8	For IB IL 24 LPSDO 8 V2-PAC outputs that are parameterized for two-channel operation, are both channels parameterized correctly for each other?	<input type="checkbox"/>		
9	For satellite inputs that are parameterized for two-channel operation, are both channels parameterized correctly for each other?	<input type="checkbox"/>		
10	For satellite outputs that are parameterized for two-channel operation, are both channels parameterized correctly for each other?	<input type="checkbox"/>		
11	Has the switch-off delay for stop category 1 been observed in the calculation of the total response time for the machine/system?	<input type="checkbox"/>		
12	Has prevention of undesired startup/restart been configured?	<input type="checkbox"/>		
13	Has it been ensured that an operator acknowledgment can only be executed by an intentional user action? (Not configured as "automatic".)	<input type="checkbox"/>		
14	Has the checklist/project information been processed in SAFECONF ("Project... Project Info" menu item)?	<input type="checkbox"/>		
No.	Requirement (optional)	Yes	No	Remark
15		<input type="checkbox"/>	<input type="checkbox"/>	
		Date	Signature (author)	
		Date	Signature (test engineer)	

B 1.3 Startup

Checklist for startup of the SafetyBridge system				
Equipment identification				
		Date		
Author		Test engineer		
Remark				
No.	Requirement (mandatory)	Yes		Remark
1	During startup, is it ensured that any person starting hazardous movements intentionally can only do so with a direct view of the danger zone?	<input type="checkbox"/>		
No.	Requirement (optional)	Yes	No	Remark
2	Are startup specifications applicable?	<input type="checkbox"/>	<input type="checkbox"/>	
3	If applicable, have startup specifications been met?	<input type="checkbox"/>	<input type="checkbox"/>	
		Date		Signature (author)
		Date		Signature (test engineer)

B 1.4 Safety functions

Enter all the safety functions for your application in this checklist.

Checklist for checking safety functions			
Equipment identification			
		Date	
Author		Test engineer	
Remark			
No.	Safety functions	Yes	Remark
1		<input type="checkbox"/>	
2		<input type="checkbox"/>	
3		<input type="checkbox"/>	
4		<input type="checkbox"/>	
5		<input type="checkbox"/>	
6		<input type="checkbox"/>	
7		<input type="checkbox"/>	
8		<input type="checkbox"/>	
9		<input type="checkbox"/>	
10		<input type="checkbox"/>	
11		<input type="checkbox"/>	
12		<input type="checkbox"/>	
13		<input type="checkbox"/>	
14		<input type="checkbox"/>	
15		<input type="checkbox"/>	
16		<input type="checkbox"/>	
		Date	Signature (author)
		Date	Signature (test engineer)

B 1.5 Validation

Checklist for validating the SafetyBridge system				
Equipment identification				
		Date		
Author		Test engineer		
Remark				
No.	Requirement (mandatory)	Yes	Remark	
1	Have the mandatory requirements for planning been met?	<input type="checkbox"/>		
2	If applicable, have the mandatory requirements for startup been met?	<input type="checkbox"/>		
3	Has validation of the safe devices used been carried out and are the results available?	<input type="checkbox"/>		
4	Are safety distances that must be observed calculated according to the response and delay times implemented?	<input type="checkbox"/>		
5	Have all the safety functions been checked successfully?	<input type="checkbox"/>		
6	Do all the islands in the system have different island addresses?	<input type="checkbox"/>		
7	Has it been ensured that in the overall system comprising SafetyBridge and any higher-level PROFIsafe system, the addresses (address within the SafetyBridge system and F-Address of the PROFIsafe system) are unique?	<input type="checkbox"/>		
8	Has the SAFECONF project been printed with the project information (name, CRC, time stamp, etc.)?	<input type="checkbox"/>		
9	Has the CRC of the SAFECONF project printout been compared with the CRC of the loaded project header and do they match?	<input type="checkbox"/>		
No.	Requirement (optional)	Yes	No	Remark
10	Are the directives and standards used listed in the declaration of conformity?	<input type="checkbox"/>	<input type="checkbox"/>	
11	Has the safety logic created in SAFECONF been packed and archived? Enter the archiving location (e.g., drive or cabinet) in the "Remark" column.	<input type="checkbox"/>	<input type="checkbox"/>	
12	Has a complete printout of the safety logic configured in SAFECONF been stored for the system?	<input type="checkbox"/>	<input type="checkbox"/>	
13	Have all fully completed checklists been stored for the system?	<input type="checkbox"/>	<input type="checkbox"/>	
		Date		Signature (author)
		Date		Signature (test engineer)

IB IL 24 LPSDO 8 V2-PAC

B 2 Checklists for the IB IL 24 LPSDO 8 V2-PAC module

B 2.1 Planning

Checklist for planning the use of the safety module				
Device type/equipment identification				
Version: HW/FW/FW		Date		
Author		Test engineer		
Remark				
No.	Requirement (mandatory)	Yes	Remark	
1	Has the current module user manual been used as the basis for planning?	<input type="checkbox"/>	Revision:	
2	Does the planned use correspond to the intended use?	<input type="checkbox"/>		
3	Has the technical data of the module been observed?	<input type="checkbox"/>		
4	Are the actuators approved for connection to the module (according to the technical data and parameterization options)?	<input type="checkbox"/>		
5	Has the voltage supply been planned according to the specifications for the protective extra-low voltage in accordance with PELV?	<input type="checkbox"/>		
6	Has the power supply of U_M and U_S from a power supply unit been planned?	<input type="checkbox"/>		
7	Is external fuse protection of the module planned (according to the specifications in this user manual for supply voltage U_M)?	<input type="checkbox"/>		
8	Is use in a control cabinet (IP54) planned?	<input type="checkbox"/>		
9	Are measures planned to prevent simple manipulation?	<input type="checkbox"/>		
10	Are measures planned to prevent connectors being mixed up?	<input type="checkbox"/>		
11	Are requirements for the actuators and cable installation observed according to the SIL/SIL CL CL/Cat./PL to be achieved and is the corresponding implementation planned?	<input type="checkbox"/>		
12	Are the specifications for the address assignment for the islands specified?	<input type="checkbox"/>		
13	Are the specifications for the parameterization for each channel specified?	<input type="checkbox"/>		
14	Are test intervals specified for testing the shutdown capability of the actuators, if this is required to achieve a SIL/SIL CL/Cat./PL?	<input type="checkbox"/>		
15	Has it been ensured that any person intentionally starting hazardous movements has a direct view of the danger zone?	<input type="checkbox"/>		
16	Have test intervals been defined?	<input type="checkbox"/>		
17	Has the switch-off delay for stop category 1 been observed in the calculation of the total response time for the machine/system?	<input type="checkbox"/>		
No.	Requirement (optional)	Yes	No	Remark
18	Have specifications for assembly and electrical installation been defined (e.g., EPLAN) and communicated to the relevant personnel?	<input type="checkbox"/>	<input type="checkbox"/>	
19	Have specifications for startup been defined and communicated to the relevant personnel?	<input type="checkbox"/>	<input type="checkbox"/>	
		Date	Signature (author)	
		Date	Signature (test engineer)	

B 2.2 Assembly and electrical installation

Checklist for assembly and electrical installation of the safety module				
Device type/equipment identification				
Version: HW/FW/FW		Date		
Author		Test engineer		
Remark				
No.	Requirement (mandatory)	Yes	Remark	
1	Was assembly and installation completed according to the specifications (specifications from the planning phase or according to the user manual)?	<input type="checkbox"/>		
2	Was the safety module installed in the control cabinet (IP54)?	<input type="checkbox"/>		
3	Do the cable cross sections correspond to the specifications?	<input type="checkbox"/>		
4	Are requirements for the actuators and cable installation observed according to the SIL/SIL CL CL/Cat./PL to be achieved and is the corresponding implementation observed?	<input type="checkbox"/>		
5	If error prevention (e.g., cross circuit to external signals) has been defined: Have the conditions for error prevention been implemented?	<input type="checkbox"/>		
6	Is the transmission speed set correctly according to the specifications?	<input type="checkbox"/>		
7	Is the operating mode set correctly according to the specifications?	<input type="checkbox"/>		
8	Is the address set correctly according to the specifications?	<input type="checkbox"/>		
No.	Requirement (optional)	Yes	No	Remark
9		<input type="checkbox"/>	<input type="checkbox"/>	
		Date		Signature (author)
		Date		Signature (test engineer)

IB IL 24 LPSDO 8 V2-PAC

B 2.3 Startup

Checklist for startup of the safety module				
Device type/equipment identification				
Version: HW/FW/FW		Date		
Author		Test engineer		
Remark				
No.	Requirement (mandatory)	Yes	Remark	
1	Was startup completed according to the specifications (specifications from the planning phase or according to the user manual)?	<input type="checkbox"/>		
2	During startup, is it ensured that any person starting hazardous movements intentionally can only do so with a direct view of the danger zone?	<input type="checkbox"/>		
3	Are safety distances that must be observed calculated according to the response and delay times implemented?	<input type="checkbox"/>		
No.	Requirement (optional)	Yes	No	Remark
4		<input type="checkbox"/>	<input type="checkbox"/>	
		Date	Signature (author)	
		Date	Signature (test engineer)	

B 2.4 Validation

Checklist for validating the safety module			
Device type/equipment identification			
Version: HW/FW/FW		Date	
Author		Test engineer	
Remark			
No.	Requirement (mandatory)	Yes	Remark
1	Have all the mandatory requirements for the "Planning" checklist been met?	<input type="checkbox"/>	
2	Have all the mandatory requirements for the "Assembly and electrical installation" checklist been met?	<input type="checkbox"/>	
3	Have all the mandatory requirements for the "Startup" checklist been met?	<input type="checkbox"/>	
4	Does the parameterization of the safe outputs correspond to the version and the actual connection of the controlled device?	<input type="checkbox"/>	
5	Has the assignment of the actuators to the safety logic outputs been checked?	<input type="checkbox"/>	
6	Has a function test been performed to check all safety functions, in which the module is involved?	<input type="checkbox"/>	
7	Have measures been taken to achieve a specific Cat.?	<input type="checkbox"/>	
8	Do all cables correspond to the specifications?	<input type="checkbox"/>	
9	Does the voltage supply correspond to the specifications for the protective extra-low voltage in accordance with PELV?	<input type="checkbox"/>	
10	Has the power supply of U_M and U_S in the Inline system from a power supply unit been implemented?	<input type="checkbox"/>	
11	Is external fuse protection of the module implemented (according to the specifications in this user manual for supply voltage U_M)?	<input type="checkbox"/>	
12	Have measures been taken to prevent simple manipulation?	<input type="checkbox"/>	
13	Have measures been taken to prevent connectors being mixed up?	<input type="checkbox"/>	
14	Are the requirements for the actuators and cable installation observed according to the SIL/SIL CL/Cat./PL to be achieved?	<input type="checkbox"/>	
15	Are the specifications for the parameterization for each channel implemented?	<input type="checkbox"/>	
16	Are test intervals specified for testing the shutdown capability of the actuators, if this is required to achieve a SIL/SIL CL/Cat./PL?	<input type="checkbox"/>	
17	Has it been ensured that any person intentionally starting hazardous movements has a direct view of the danger zone?	<input type="checkbox"/>	
		Date	Signature (author)
		Date	Signature (test engineer)

C Appendix: Index

A

Abbreviations	1-6
Acknowledgment	A-31
Actuators	
Connection options	2-5
Requirements	2-4
App-Ack-LPSDO	A-20
Assembly	4-4

C

Configuration error	A-32
Conformance with EMC Directive	10-6
Current carrying capacity	3-1, 3-2

D

Data-x	A-17
Decommissioning	9-1
Dev-Ack-LPSDO	A-19
Dev-Ack-x	A-17
Dev-Diag-x	A-17
Device error	A-31
Device errors	
Outputs	2-9
Serious errors	2-9
Diagnostic indicators	2-6
Directives	1-4
Disposal	9-1
Documentation, latest	1-5

E

Enable-LPSDO	A-20
Enable-PSDO	A-20
Error	
Behavior in the event of an error	A-31
Configuration	A-32
Device	A-31
Parameterization	A-32
System	A-31
Error classes	A-31
Error messages	A-31
Errors	
Acknowledgment	8-8

General	8-7
Outputs	8-4
Parameterization	8-6
Removal	8-1
Supply voltage	8-5

F

Feedback-Data-LPSDO	A-20
Feedback-Data-PSDO	A-20
Free running circuit	6-2

H

Housing dimensions	2-2
--------------------------	-----

I

I/O errors	A-32
ID code	2-10
Indicators, diagnostic and status	2-6
Input address area	2-10
Installation	
Instructions	4-1
Insulation rating	1-3
INTERBUS	
Process data words	2-10
INTERBUS-Safety	
Hotline	1-6
Island node	A-5
Island number	5-1

L

Length code	2-10
Location ID	5-1

M

Maintenance	9-1
module	2-6
Mounting	
Location	4-1

IB IL 24 LPSDO 8 V2-PAC**O**

Output address area	2-10
Outputs	2-3
Device errors	2-9
Errors	8-4
I/O errors	2-8
Parameterization	5-2
Positive switching	2-3
Requirements for actuators	2-4
Single-channel assignment	2-3
Two-channel assignment	2-3

P

Package slip.....	4-1
Parameter channel.....	2-10
Parameterization.....	5-1
Outputs.....	5-2
Parameterization error.....	A-32
PELV.....	1-3, 3-1, 3-2
Power supply unit.....	1-3
Processing time of the input.....	A-29
PROFIsafe address.....	5-1
Protective circuit.....	6-2
Prot-x	A-17

Q

Qualified personnel	1-1
---------------------------	-----

R

Register	
App-Ack-LPSDO	A-20
Data-x.....	A-17
Dev-Ack-LPSDO	A-19
Dev-Ack-x.....	A-17
Dev-Diag-x	A-17
Enable-LPSDO	A-20
Enable-PSDO.....	A-20
Feedback-Data-LPSDO	A-20
Feedback-Data-PSDO	A-20
Prot-x.....	A-17

Register length.....	2-10
Remote device.....	A-5
Removal.....	4-4
Repair	9-1
Replacement, module	7-3
Response time	
Typical.....	A-28
Response time of the actuator	A-30
Response time of the sensor.....	A-29
Restart	7-3, A-33

S

Safe state.....	2-8
Operating state.....	2-8
Outputs	2-8, 2-9
Safety notes	1-1
SafetyBridge island.....	A-5
Satellite	A-5
Security seal	1-2
Service information	A-31
Shutdown time	A-29
Guaranteed	A-29
Required	A-29
smartSafe system	A-4
Standards	1-4
Startup	7-1, A-33
Status indicators	2-6
Stopping time of the machine.....	A-30
Supply voltage	
UM	3-1, 3-2
System error	A-31

T

Test pulses	2-4
Transmission speed.....	1-2
Setting.....	4-2

U

Usage, correct	1-5
----------------------	-----

V

Validation	7-3
------------------	-----

D Appendix: Revision history

Revision	Date	Contents	
01		Not published	
02	2011-05-17	First publication	
03	2011-08-29		FW 101 added
		Page 10-7	Connector set 2700722 added
04	2013-06-25	Page 4-3	Switch position for SafetyBridge V3 added
05	2019-08-07	Outside + inside of co- vering sheet	Order No. deleted Revision HW/FW/FW edited



**SCATTERGOOD
& JOHNSON LTD**
ELECTRICAL ENGINEERING & FLUID CONTROL DISTRIBUTORS

Est.1899

At Scattergood & Johnson Ltd, we pride ourselves on being a technical distributor to specialist industries.

Working with a range of quality product suppliers across a number of specialist markets, we are not your average 'box shifter' - we are your technical and supply chain partner.

We fully support every product we sell - for free! Our internal team and external sales engineers can answer any product or application question, no matter the complexity.

Backing up this technical ability is a range of 50,000+ products available from stock for nationwide next day delivery (same day if required!), or you can collect what you need from any of our trade counters around the UK.

Select your specialist interest below to learn more about how we can help.

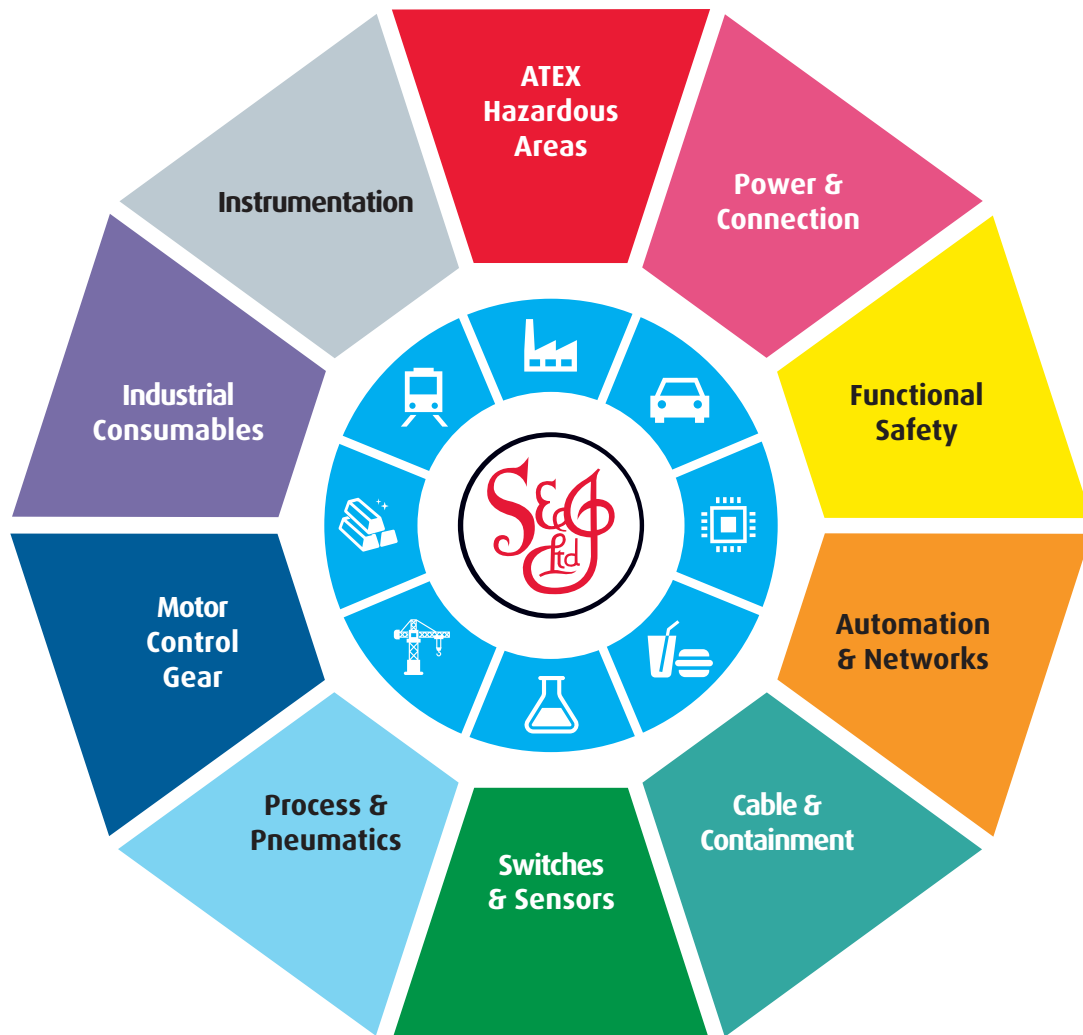

Online, In Branch and On the Road - Scattergood & Johnson Ltd, there when you need us.

www.scatts.co.uk