



Installing and operating the AXC 1050 and AXC 1050 XC controllers

User manual

User manual

Installing and operating the AXC 1050 and AXC 1050 XC controllers

2017-06-02

Designation: UM EN AXC 1050 (XC)

Revision: 03

Order No.: —

This user manual is valid for:

Designation	As of version (HW)	As of version (FW)	Order No.
AXC 1050	03	3.00	2700988
AXC 1050 XC	03	3.00	2701295

Please observe the following notes

User group of this manual

The use of products described in this manual is oriented exclusively to:

- Qualified electricians or persons instructed by them, who are familiar with applicable standards and other regulations regarding electrical engineering and, in particular, the relevant safety concepts.
- Qualified application programmers and software engineers, who are familiar with the safety concepts of automation technology and applicable standards.

Explanation of symbols used and signal words



This is the safety alert symbol. It is used to alert you to potential personal injury hazards. Obey all safety measures that follow this symbol to avoid possible injury or death.

There are three different categories of personal injury that are indicated with a signal word.

DANGER This indicates a hazardous situation which, if not avoided, will result in death or serious injury.

WARNING This indicates a hazardous situation which, if not avoided, could result in death or serious injury.

CAUTION This indicates a hazardous situation which, if not avoided, could result in minor or moderate injury.



This symbol together with the signal word **NOTE** and the accompanying text alert the reader to a situation which may cause damage or malfunction to the device, hardware/software, or surrounding property.



This symbol and the accompanying text provide the reader with additional information or refer to detailed sources of information.

How to contact us

Internet

Up-to-date information on Phoenix Contact products and our Terms and Conditions can be found on the Internet at:

phoenixcontact.com

Make sure you always use the latest documentation.

It can be downloaded at:

phoenixcontact.net/products

Subsidiaries

If there are any problems that cannot be solved using the documentation, please contact your Phoenix Contact subsidiary.

Subsidiary contact information is available at phoenixcontact.com.

Published by

PHOENIX CONTACT GmbH & Co. KG
Flachsmarktstraße 8
32825 Blomberg
GERMANY

Should you have any suggestions or recommendations for improvement of the contents and layout of our manuals, please send your comments to:

tecdoc@phoenixcontact.com

Please observe the following notes

General terms and conditions of use for technical documentation

Phoenix Contact reserves the right to alter, correct, and/or improve the technical documentation and the products described in the technical documentation at its own discretion and without giving prior notice, insofar as this is reasonable for the user. The same applies to any technical changes that serve the purpose of technical progress.

The receipt of technical documentation (in particular user documentation) does not constitute any further duty on the part of Phoenix Contact to furnish information on modifications to products and/or technical documentation. You are responsible to verify the suitability and intended use of the products in your specific application, in particular with regard to observing the applicable standards and regulations. All information made available in the technical data is supplied without any accompanying guarantee, whether expressly mentioned, implied or tacitly assumed.

In general, the provisions of the current standard Terms and Conditions of Phoenix Contact apply exclusively, in particular as concerns any warranty liability.

This manual, including all illustrations contained herein, is copyright protected. Any changes to the contents or the publication of extracts of this document is prohibited.

Phoenix Contact reserves the right to register its own intellectual property rights for the product identifications of Phoenix Contact products that are used here. Registration of such intellectual property rights by third parties is prohibited.

Other product identifications may be afforded legal protection, even where they may not be indicated as such.

Table of contents

1	For your safety	9
1.1	Intended use.....	9
1.2	Modifications	9
1.3	Safety notes.....	9
1.4	Notes on using the AXC 1050 XC controller in potentially explosive areas of zone 2.....	11
2	From transport to unpacking	13
2.1	Transport	13
2.2	Storage.....	13
2.3	Checking the delivery	13
2.4	Unpacking	14
3	Description of the AXC 1050 (XC)	15
3.1	Hardware and software requirements.....	15
3.2	General description of the controller	15
3.3	Possible fields of application of the controller	19
3.3.1	Controller as a distributed controller of an Axioline F station	19
3.3.2	The AXC 1050 (XC) as a PROFINET controller in a PROFINET network	20
3.3.3	The AXC 1050 (XC) as a PROFINET device in a PROFINET network	21
3.3.4	System redundancy with AXC 1050 or AXC 1050 XC	22
3.4	Connection and operating elements	24
3.5	Diagnostics and status indicators	25
3.6	Mode selector switch	29
3.7	Reset button (concealed)	30
3.8	Parameterization memory.....	31
3.9	Internal basic circuit diagram	32
3.10	Communication paths.....	33
3.10.1	Ethernet	34
3.10.2	Service interface (Micro-USB type B)	35
3.11	Supply plug.....	36
3.12	Bus base module.....	36
4	Mounting hardware	37
4.1	Safety notes.....	37
4.2	Basics.....	38
4.3	Structure of an Axioline F station	40
4.4	Mounting the controller	41

AXC 1050 (XC)

4.5	Inserting the SD card	42
5	Connecting and wiring hardware	43
5.1	Supply voltage	43
5.1.1	Sizing of the power supply	43
5.1.2	Connecting the power supply	44
5.2	Connecting Ethernet.....	46
5.3	Connecting USB cable	46
6	Startup	47
6.1	Installing PC Worx (Express)	47
6.2	Creating a new project.....	48
6.3	Assigning the IP address for the controller.....	49
6.3.1	Discovery and basic Configuration Protocol (DCP)	49
6.3.2	BootP server	52
6.3.3	Assigning the IP address via the USB interface	56
6.3.4	Dynamic Host Configuration Protocol (DHCP)	59
6.4	Reading Axioline F.....	61
6.5	The PROFINET controller/device function of the AXC 1050 (XC).....	63
6.5.1	Activating the PROFINET controller/device function	63
6.5.2	Integrating the AXC 1050 (XC) as a PROFINET controller	66
6.5.3	Integrating the AXC 1050 (XC) as a PROFINET device	67
6.6	Setting the real-time clock	71
6.7	Compiling after completing the bus topology	71
6.8	Using the SD card as the main memory or additional memory.....	72
6.8.1	Main memory	72
6.8.2	Additional memory	74
6.9	Creating the program and variables.....	78
6.10	Compiling after creating the program.....	78
6.11	Assigning process data	78
6.12	Compiling and sending a project and performing a cold restart	78
7	Useful information about the PC Worx software	79
7.1	Diagnosing the Axioline F system.....	79
7.2	Applying the IP address immediately.....	86
7.3	Parameterization memory and Internet Explorer®	87
7.3.1	Activating the FTP functionality of Internet Explorer®	88
7.3.2	Activating/deactivating the FTP server	89
7.3.3	Creating, renaming or deleting via the FTP directory	90
7.3.4	Restricting FTP access	91
7.4	Web server	94

Table of contents

7.4.1	Activating/deactivating the HTTP server	94
7.4.2	Using the Hypertext Transfer Protocol Secure (HTTPS)	95
7.5	Sending e-mails securely.....	96
7.6	Activating/deactivating specific ports.....	97
7.7	Activating/deactivating the journaling function	98
7.8	Activating/deactivating or reading the MRP client function	99
7.9	Event task for the "Power failure" event	100
7.10	Function blocks for handling files on the parameterization memory.....	102
7.11	Function blocks for Ethernet communication	103
7.11.1	IP communication blocks	103
7.11.2	ETH communication blocks in accordance with IEEE 802.3	104
7.12	Functional blocks for AxioLine F	109
7.12.1	Functional blocks for acyclic PDI communication	109
7.12.2	AX_CONTROL function block	109
7.13	Function block for UTC	110
7.14	IP_INFO function block.....	111
7.15	Alignment	112
8	System variables and status information	115
8.1	General notes	115
8.2	Diagnostic status register	115
8.3	Diagnostic parameter register.....	116
8.4	PROFINET system variables	117
8.5	IEC-61131 runtime system	120
8.6	Control processor	121
8.7	Ethernet interfaces.....	122
8.8	SD card.....	122
8.9	Energy storage, real-time clock	122
8.10	Power supplies	122
8.11	Mode selector switch	123
8.12	Project-related system variables.....	123
8.13	System time.....	123
9	Web-based management (WBM)	124
9.1	Installing the WBM.....	124
9.2	Establishing a connection with the WBM	124
9.3	Changing the language.....	125
9.4	Areas and functions.....	125
9.4.1	"Information" area	126

AXC 1050 (XC)

9.4.2	"Diagnostics" area	129
9.4.3	"Administration" area	133
9.4.4	"WebVisu" area	138
10	Removing hardware	139
10.1	Safety notes.....	139
10.2	Removing cables.....	140
10.3	Removing the plug.....	140
10.4	Removing the SD card.....	141
10.5	Removing the controller.....	141
11	After usage	142
11.1	Maintenance and servicing.....	142
11.2	Device replacement.....	142
11.3	Device defect and repair.....	143
11.4	Disposal.....	143
12	Technical data and ordering data	144
12.1	Technical data	144
12.2	Ordering data.....	148
12.2.1	Controller	148
12.2.2	Accessories	148
12.2.3	Software	149
12.2.4	Documentation	149
A	Appendix	150
A 1	Performing updates	150
A 2	Derating for the controller AXC 1050 XC	152
A 3	Tested successfully: Use under extreme ambient conditions	153
B	Appendix for document lists.....	154
B 1	List of figures	154
B 2	List of tables	158
B 3	Index.....	160

1 For your safety

1.1 Intended use

The AXC 1050 and AXC 1050 XC controllers are modular, small-scale controllers that can be used for smaller and medium-sized applications. The devices belong to the IP20 protection class and are designed for use in closed control cabinets or control boxes (terminal boxes) with an IP54 degree of protection or higher.

The devices are designed for use in industrial environments.

1.2 Modifications

Modifications to hardware and software of the device are not permitted.

1.3 Safety notes

Observe the country-specific installation, safety, and accident prevention regulations.

During commissioning and maintenance work, proceed in accordance with the five safety rules of DIN EN 50110-1. In general, the rules should be observed in the specified order:

- Disconnect safely
- Ensure power cannot be switched on again
- Verify safe isolation from the supply
- Ground and short circuit
- Cover or safeguard adjacent live parts

Once the work is complete, perform the above steps again in reverse order.

**NOTE: Property damage due to impermissible load**

IP20 degree of protection (IEC 60529/EN 60529) requires that the devices be used in a clean and dry environment. If you use devices in an environment that is outside of the specified limits, this may cause damage to the devices.

- Do not subject the devices to mechanical and/or thermal loads that exceed the specified limits.

AXC 1050 (XC)

**NOTE: : Risk of unauthorized network access**

Connecting devices to a network via Ethernet always entails the risk of unauthorized access to the network.

Therefore, please check your application for any option of deactivating active communication channels (for instance SNMP, FTP, BootP, DCP, etc.), or setting passwords to prevent third parties from accessing the controller without authorization and modifying the system.

Because of the controller's communication interfaces, we advise against using the controller in safety-critical applications without additional security appliances.

Please take additional protective measures according to the IT security requirements and the standards applicable to your application (for instance virtual networks (VPN) for remote maintenance access, firewalls, etc.) for protection against unauthorized network access.

On first request, you shall release Phoenix Contact and the companies associated with Phoenix Contact GmbH & Co. KG, Flachsmarktstraße 8, 32825 Blomberg in accordance with §§ 15 ff. AktG or German Stock Corporation Act (hereinafter collectively referred to as "Phoenix Contact") from all third-party claims that are made due to improper use.

For the protection of networks for remote maintenance via VPN, Phoenix Contact offers the mGuard product series security appliances which you can find described in the latest Phoenix Contact catalog (phoenixcontact.net/products).

Additional measures for protection from unauthorized network access can be found in the AH EN INDUSTRIAL SECURITY application note. The application note can be downloaded at phoenixcontact.net/products.

1.4 Notes on using the AXC 1050 XC controller in potentially explosive areas of zone 2

Approval in accordance with the 2014/34/EU directive

 II 3 G Ex nA IIC T4 Gc X



WARNING: Explosion hazard

Please make sure that the following notes and instructions are observed!

Installation notes

1. The controller is a device of category 3 and is suitable for installation in potentially explosive areas of zone 2.
The controller meets the requirements of EN 60079-0:2012+A11:2013 and EN 60079-15:2010.
2. The controller must be installed, started up, operated, and maintained by qualified specialist personnel only.
3. Follow the installation instructions described in this user manual, in the device-specific packing slip, and in the UM EN AXL F SYS INST user manual.
4. When installing and operating the device, the applicable safety directives (including national safety directives), accident prevention regulations, as well as general technical regulations must be observed.
5. For the safety data, please refer to the corresponding documentation (user manual, packing slip) and the certificates (declaration of conformity and other approvals, if applicable).
6. Access to the circuits inside the controller is not permitted. Do not repair the controller yourself but replace it with an approved controller of the same type.
Repairs may only be performed by the manufacturer. The manufacturer is not liable for damage resulting from noncompliance.
7. The IP20 degree of protection (EN 60529) requires that the device be used in a clean and dry environment.
8. Do not subject the controller to mechanical strain and/or thermal loads that exceed the limits specified in the product documentation.
9. The controller is not designed for use in potentially dust-explosive atmospheres. If dust is present, install the device in suitable, approved housing. Please note the surface temperature of the housing.
10. Stop the device and immediately remove it from the potentially explosive area if it is damaged or was subject to an impermissible load or stored incorrectly or if it malfunctions.

AXC 1050 (XC)

Installation in zone 2

1. Observe the specified conditions for use in potentially explosive areas.
2. Install the device in a suitable approved housing (with at least IP54 protection according to EN 60529) that meets the requirements of EN 60079-15:2010. Pay attention to the requirements of EN 60079-14.
3. The following work is only permitted in potentially explosive areas when the power is disconnected:
 - Snapping on or disconnecting the bus base modules
 - Snapping the devices onto the bus base modules and the DIN rail
 - Removing the devices from the bus base modules and the DIN rail
 - Connection and disconnection of cables
 - Inserting and removing the SD card
4. Connect the DIN rail to protective earth ground.
5. Only devices that are designed for operation in the Ex area of zone 2 and for the conditions at the specific installation location may be connected to the circuits in zone 2.
6. The device may only be operated in potentially explosive areas when all connectors are fully plugged in.
7. To ensure safe operation, the RJ45 connector must have a fully functioning locking clip. Repair any damaged connectors immediately.
8. For safe operation with the SD card, it must be completely plugged and snapped in.
9. The service interface may only be used if there is no potentially explosive atmosphere.

Restrictions/limit values

1. **Only Axioline F modules that have been approved for potentially explosive areas may be connected to the controller.**

Before using an Axioline F module in the potentially explosive area of zone 2, check that the Axioline F module is approved for installation in this area. For a list of modules that are approved for the potentially explosive area of zone 2, please refer to the AH EN AXC/AXL F EX ZONE 2 application note.
2. Observe the restrictions/limit values specified in the product documentation for the devices.
3. Make sure that the maximum permitted current consumption on the U_{BUS} is not exceeded.

Refer to the "power supply to U_{BUS} " value applicable to the controller (see section "Controller supply" on page 145).
4. The maximum permissible current for each spring-cage contact is 8 A.

2 From transport to unpacking

2.1 Transport

The device is delivered in cardboard packaging.

- Only transport the device to its destination in its original packaging.
- On the packaging, please note the instructions regarding handling as well as moisture, shock, tilt, and temperature indicators.
- Observe the humidity specifications and the temperature range specified for transport (see Section "Technical data" on page 144).
- Never climb onto the device or packaging.
- When transporting the equipment or storing it temporarily, make sure that the surfaces are protected from the elements and any external influences, and that they are kept dry and clean.

2.2 Storage

The storage location must meet the following requirements:

- Dry
- Protected from unauthorized access
- Protected from harmful environmental influences (such as UV light)
- Temperature range: -40°C ... +85°C
- Air pressure: 58 kPa ... 106 kPa (up to 4500 m above sea level)
- Permissible humidity: 10% ... 95%

2.3 Checking the delivery

- Check the delivery for transport damage.

Damaged packaging is an indicator of potential damage to the device that may have occurred during transportation. This could result in a malfunction.

- Submit claims for any transport damage immediately, and inform the Phoenix Contact or your supplier as well as the shipping company without delay.
- Enclose photos which clearly document the damage to the packaging and/or delivery together with your claim.
- Immediately after delivery, refer to the delivery note to check the completeness of the contents of the packaging.
- Keep the box and packaging material in case it is necessary to return the product.
- We strongly recommend using the original packaging to return equipment.
- If the original packaging is no longer available, observe the following points:
 - Observe the humidity specifications and the temperature range specified for transport (see "Ambient conditions" on page 147).
 - If necessary, use dehumidifying agents.
 - Use appropriate ESD packaging to protect components that are sensitive to electrostatic discharge.

AXC 1050 (XC)

- Make sure that the packaging you select is large enough and sufficiently thick.
- Only use plastic bubble wrap sheets as wadding.
- Attach warnings to the transport packaging so that they are clearly visible.
- Please be aware that the delivery note is to be placed inside the package in the case of packages that are to remain within the same country. However, if the package is being sent abroad, the delivery note must be placed inside a delivery note pocket and attached to the outside so that it is clearly visible.

Scope of supply

- Controller AXC 1050 (XC), including packing slip
- Bus base module AXL F BS BK
- Supply plug AXL CN S/UL

2.4 Unpacking

The AXC 1050 (XC) is supplied in the packaging together with a packing slip with installation instructions.

- Read the complete packing slip carefully before unpacking the controller.

**NOTE: Electrostatic discharge!**

The device contains components that can be damaged or destroyed by electrostatic discharge. When handling the device, observe the necessary safety precautions against electrostatic discharge (ESD) according to EN 61340-5-1 and IEC 61340-5-1.

**NOTE: Property damage due to noncompliance with ESD notes**

If the ESD notes are not observed during unpacking and packaging, the device may be damaged.

- Observe the ESD notes during unpacking and packaging.

3 Description of the AXC 1050 (XC)

3.1 Hardware and software requirements

Hardware/software	Description	
	AXC 1050	AXC 1050 XC
Controller		
SD card	For ordering data, see Section "Ordering data" on page 148.	
Ethernet cable	Ethernet cable for connecting the controller to a PC	
USB cable	USB cable for connecting the controller to a PC, see Section "Ordering data" on page 148.	
Automation software versions		
PC Worx	≥ 6.30*	
PC Worx Express		

* Part of AUTOMATIONWORX Software Suite 2017 Version 1.84

3.2 General description of the controller



The AXC 1050 and AXC 1050 XC controllers have the same appearance. They only differ with regard to a function. In the following, the term controller or AXC 1050 (XC) is therefore used in general. Where necessary, any differences are indicated accordingly.

The controller meets the requirements of classification societies for maritime applications. For the latest approvals, please visit phoenixcontact.net/products.

The AXC 1050 XC controller is approved for use in potentially explosive areas of zone 2. Observe the notes in Section "Notes on using the AXC 1050 XC controller in potentially explosive areas of zone 2" on page 11.

The AXC 1050 XC controller is approved for use under extreme ambient conditions. Please refer to the notes in the technical data in "Ambient conditions" on page 147.

The AXC 1050 (XC) is a modular small-scale controller with integrated Ethernet and an Axioline F local bus connection.

An Axioline F station is automatically created by connecting Axioline F modules to the controller. The Axioline F local bus (referred to as local bus in this document) is implemented by arranging bus base modules side-by-side.

AXC 1050 (XC)

The controller consists of an electronics module (1) and a bus base module (2).

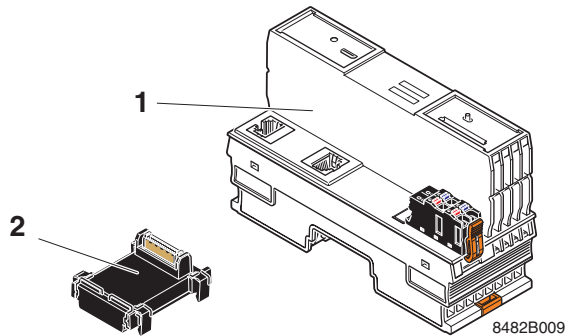

Figure 3-1 Components of the controller

IEC 61131 control performance

The controller is consistently configured and programmed in accordance with IEC 61131 using the PC Worx automation software. The powerful processor can be programmed in all five IEC 61131 programming languages and ensures quick control task processing.

IEC 61850 communication

As of firmware version 3.00, the controller can be used as an IED (Intelligent Electronic Device) for communication in accordance with IEC 61850. You can find information on configuration in the "IEC 61850 configuration of a Phoenix Contact IED" user manual. The user manual can be downloaded at phoenixcontact.net/products.

Integrated Ethernet interfaces

The controller features two Ethernet interfaces for TCP/IP/UDP/IP communication in the Ethernet network.

Integrated communication functions enable direct and effective data exchange. Using the IP_USEND and IP_URCV communication blocks, information, e.g., necessary coupling variables, can be exchanged between controllers via Ethernet. This enables distributed, modular automation solutions to be configured.

When using the AX OPC server provided in the AUTOMATIONWORX Software Suite, controller data is available in the Ethernet network in a standardized format and can be used in visualization projects.

PROFINET controller/device functions

The PROFINET protocol can be used via the Ethernet interfaces of the controller. In this case, the controller can be used as a PROFINET controller or PROFINET device, depending on the configuration. It cannot be used as a PROFINET controller and device concurrently.



For information on how to configure the controller in the PC Worx software as a PROFINET controller and/or PROFINET device, please refer to Section "The PROFINET controller/device function of the AXC 1050 (XC)" on page 63.

Modbus functionality

The Modbus TCP communication protocol can be used via the Ethernet interfaces of the controller. The controller can be used as a Modbus/TCP client and/or as a Modbus/TCP server (as of firmware version 3.00 and AUTOMATIONWORX Software Suite 2017 Version 1.84). For additional information, please refer to the AH EN MODBUS TCP application note.

Axioline F local bus

There is an interface to the Axioline F local bus on the bottom of the controller. Bus base modules are used to carry the communications power and the bus signals from the controller through the Axioline F station. A bus base module is supplied with the controller.

Up to 63 Axioline F modules can be connected to the controller. The maximum number of modules that can be operated depends on the current consumption of the modules. The total current consumption of all devices aligned on the controller must not exceed the maximum current that the controller supplies for the local bus (2 A).

**NOTE: Electronics may be damaged if overloaded**

The permissible number of devices that can be connected depends on the structure of the Axioline F. The current consumption for each device is specified in every module-specific data sheet and may vary. If the total current consumption for the connected devices exceeds the maximum current supplied by the controller, this can damage the electronics due to overload.

- Observe the current consumption of each device when configuring an Axioline F station.

**Axioline F/
System and firmware**

For system-specific information on the Axioline F system, please refer to the online help for the PC Worx software and the "Axioline F: System and installation" (UM EN AXL F SYS INST) and "Axioline F: Diagnostic registers and error messages" (UM EN AXL F SYS DIAG) user manuals.

MRP

The MRP Media Redundancy Protocol protocol can be used via the Ethernet interfaces of the controller. The controller supports the MRP client function, which can be enabled or disabled via PC Worx. This function is disabled by default. If the function is enabled, it remains enabled after the supply voltage is switched off and on. If the controller has been reset to the delivery state, the MRP client function will also be disabled again. In a ring with Media Redundancy Protocol, maximum switch-over times of up to 200 ms can be expected.

Service interface

The service interface can be used to connect the controller to a PC running the PC Worx (Express)/Diag+ or Startup+ software. The service interface is designed as a type B Micro-USB socket.

The controller is detected as a USB device by the Windows[®] operating system if the corresponding driver is installed on your PC (also refer to Section 6.1).

The following functions are available in the PC Worx (Express) software when using the service interface:

- Setting/reading in the IP address of the controller
- Setting the real-time clock of the controller
- Enabling/disabling the SNMP agent
- Enabling/disabling the PROFINET controller/device function of the controller
- Resetting the controller (reset)
- Online diagnostics of the controller using the Diag+ diagnostics software
- Enabling/disabling the MRP client function

USB driver

In order to use the service interface of the controller, the "Phoenix Contact USB to UART Interface" driver must be installed. This must be selected explicitly when installing the AUTOMATIONWORX Software Suite. See also Section 6.1.

AXC 1050 (XC)**Parameterization memory/SD card**

The controller has an internal parameterization memory. This memory can be used to store programs and configurations which belong to your project, e.g., the visualization project. If the internal parameterization memory is not large enough for your application program, the controller can be operated using an SD card. The SD card is optional and not required to operate the controller.



The SD card is not supplied as standard with the controller.

- Only use a parameterization memory provided by Phoenix Contact (for ordering data, see Section "Accessories" on page 148).

**NOTE: Damaging the SD card after formatting**

The SD card is already formatted and is intended for use with Phoenix Contact devices. When you format the SD card, certain information on the SD card that is required for use with Phoenix Contact devices is lost. After formatting, you can no longer use the SD card to operate the controller.

- Make sure that the SD card is not formatted.

Visualization

You can create visualizations for the AXC 1050 (XC) using WebVisit or atvise® builder software (as of firmware 2.10).



For additional information on the atvise® builder software, refer to the AH EN ILC 1X1, AXC 1050(/XC) – ATVISE application note available online at phoenixcontact.net/products.

UPS

In the event that the AXC 1050 (XC) supply voltage fails, the integrated UPS (see Figure 3-10 on page 32) buffers the supply voltage of the electronics inside the device. The supply voltages of the Axioline F local bus or connected Axioline F devices are not buffered. Failure of the supply voltage is detected by the firmware. You can start a task such as data backup to protect the system. You can also define an event task for the "voltage failure" event (see Section 7.9). You can query the status of the UPS using system variables (see Section 8.10).

Real-time clock

In the event that the supply voltage fails, the real-time clock integrated in the controller is buffered (see Section "Technical data" on page 144). You can query the status of the real-time clock using system variables (see Section 8.9).

3.3 Possible fields of application of the controller

3.3.1 Controller as a distributed controller of an Axioline F station

The controller can be used as a distributed controller of an Axioline F station which is connected to an Ethernet system. A maximum of 63 devices (Axioline F modules) can be connected to the controller. The maximum number of devices that can be aligned depends on the current consumption of the devices. The total current consumption of all devices aligned on the controller must not exceed the maximum current that the controller supplies for the local bus (2 A).

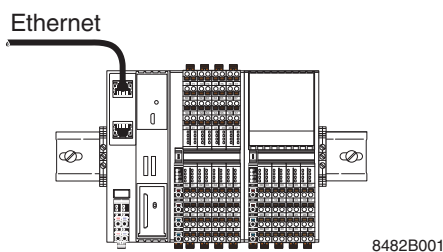

Figure 3-2 Axioline F station with AXC 1050 controller

3.3.2 The AXC 1050 (XC) as a PROFINET controller in a PROFINET network

Figure 3-3 shows the example of an AXC 1050 as a PROFINET controller in a PROFINET network.

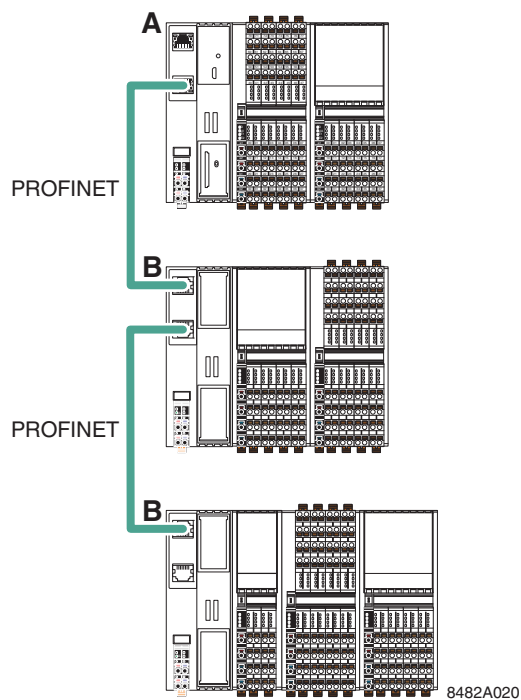

Figure 3-3 PROFINET controller with the AXC 1050 as an example

Key:

- A** PROFINET controller (in the example: AXC 1050)
- B** PROFINET device (in the example: PROFINET bus coupler with connected Axioline F I/O modules)



For additional information on how to integrate the AXC 1050 and AXC 1050 XC into a PROFINET network as a PROFINET controller, please refer to Section "Integrating the AXC 1050 (XC) as a PROFINET controller" on page 66.

3.3.3 The AXC 1050 (XC) as a PROFINET device in a PROFINET network

Figure 3-4 shows the example of an AXC 1050 as a PROFINET device in a PROFINET network.

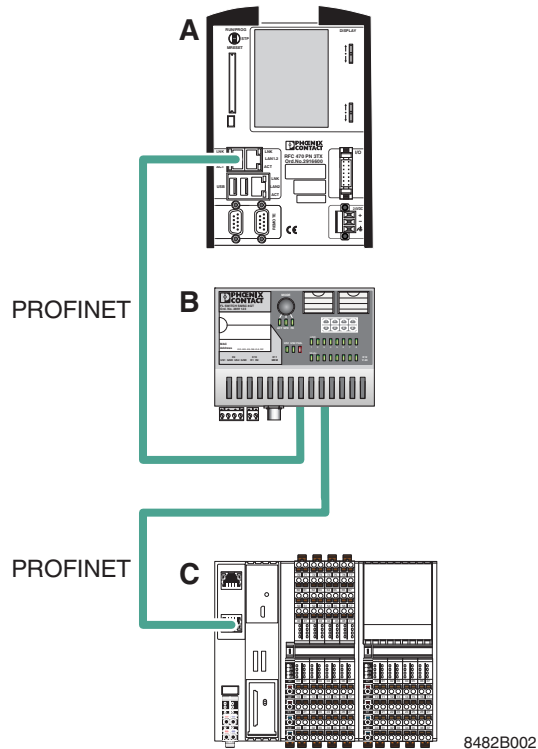

Figure 3-4 PROFINET device using the AXC 1050 as an example

Key:

- A** PROFINET controller (in the example: RFC 470 PN 3TX Remote Field Controller)
- B** Managed switch (in the example: FL SWITCH SMCS ...)
- C** PROFINET device (in the example: AXC 1050)



For additional information on how to integrate the controller into a PROFINET network as a PROFINET device, please refer to Section "Integrating the AXC 1050 (XC) as a PROFINET device" on page 67.

3.3.4 System redundancy with AXC 1050 or AXC 1050 XC

Figure 3-5 shows an application example of system redundancy. In the example, two RFC 460R PN 3TX controllers connected via a fiber optic synchronization connection (SYNC) form the higher-level redundant control system. The higher-level control system controls a lower-level PROFINET ring network that is configured as redundant using the MRP Media Redundancy Protocol. In the example, the AXC 1050 controller operates as a PROFINET device with control function and is connected to the PROFINET network via a switch.

Identical application programs run on both higher-level PROFINET controllers. In the example, controller A is the FIRST PROFINET controller and controller B is the SECOND PROFINET controller. Which of the two controllers controls the process depends on the redundancy role (PRIMARY/BACKUP) of the controller, which may change depending on the redundancy status.



For additional information on redundancy, please refer to the UM EN RFC 460R PN 3TX user manual and the AH EN APPLICATIVE SYSTEM REDUNDANCY application note. These documents can be downloaded at phoenixcontact.net/products.

Redundant control system
(with RFC 460R PN 3TX)

Network redundancy with MRP
Media Redundancy Protocol

PROFINET device (with
Phoenix Redundancy Layer) in
the redundancy ring (supports
MRP)

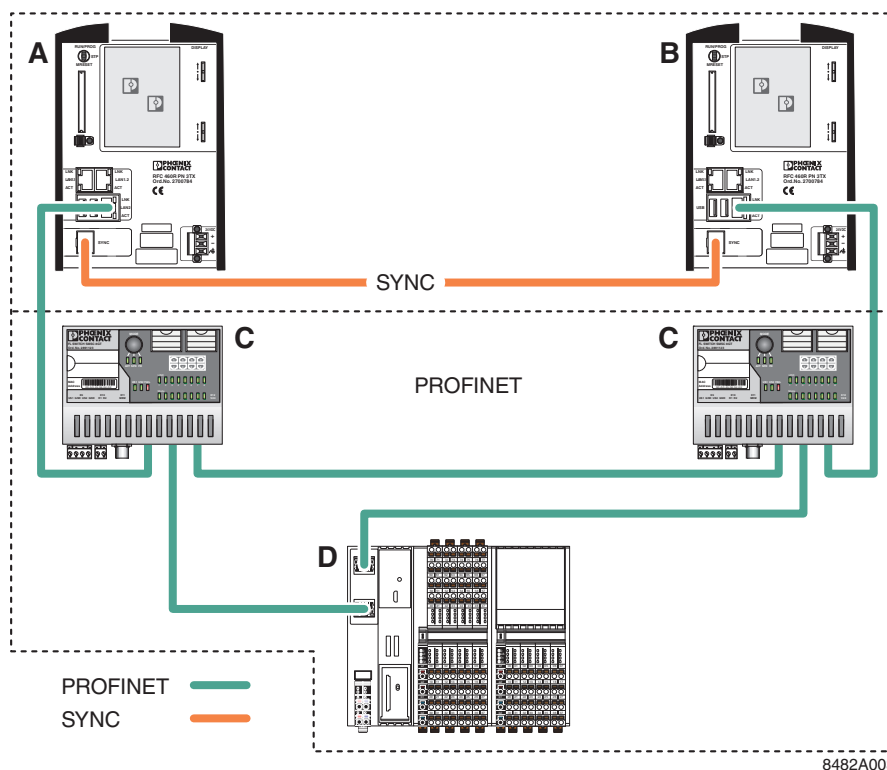

Figure 3-5 Redundant higher-level control system and lower-level network ring redundancy using MRP

Description of the AXC 1050 (XC)

Key:

- A** FIRST PROFINET controller (in the example: RFC 460R PN 3TX);
the redundancy role (PRIMARY/BACKUP) may change depending on the redundancy status
- B** SECOND PROFINET controller (in the example: RFC 460R PN 3TX);
the redundancy role (BACKUP/PRIMARY) may change depending on the redundancy status
- C** Infrastructure components (in the example: FL SWITCH SMCS ... managed switches)
- D** PROFINET device with control function (in the example: AXC 1050 with activated PROFINET device function and Phoenix Redundancy Layer)

3.4 Connection and operating elements

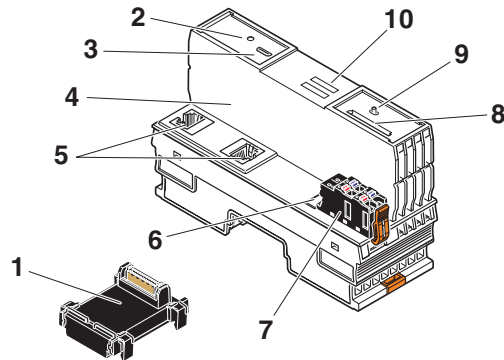

Figure 3-6 Connection and operating elements of the controller (AXC 1050 and AXC 1050 XC)

The controller consists of the following components:

- 1 Bus base module
- 2 Reset button
- 3 Service interface (X4)
- 4 Electronics module
- 5 Ethernet interfaces (X1, X2)
- 6 FE tab (X3), 2.8 mm, for optional connection to functional earth ground
- 7 Supply plug (connector for connecting the supply voltage (communications power U_L))
- 8 SD card holder



The SD card is not supplied as standard with the controller.

Please refer to the ordering data in Section "Accessories" on page 148.

- 9 Mode selector switch
- 10 Diagnostics and status indicators

3.5 Diagnostics and status indicators

The diagnostics and status indicators are used for quick local error diagnostics.

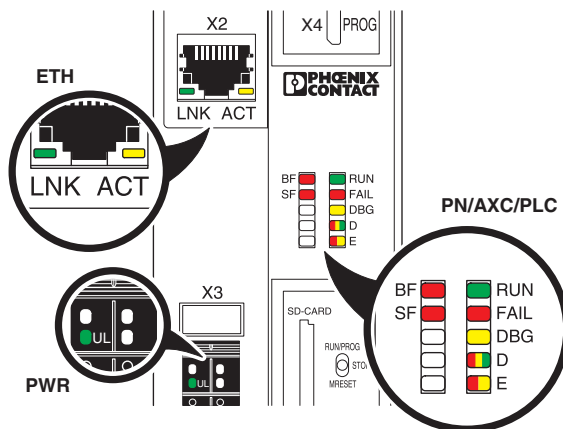

Figure 3-7 Diagnostics and status indicators

Table 3-1 Diagnostics and status indicators of the controller

Designation	Color	Meaning	State	Description
PN: PROFINET controller/device function				
BF	Red	Status of PROFINET communication/communication errors	AXC 1050 (XC) as a PROFINET controller	
			Off	The AXC 1050 (XC) has established an active communication connection to each configured PROFINET device.
			On	No link status at the Ethernet interfaces and/or no 100-Mbit transmission and/or no full-duplex operation.
			Flashing (1 Hz)	Link status present, at least one configured PROFINET device has no communication connection.
			AXC 1050 (XC) as a PROFINET device	
			Off	A PROFINET controller has established an active communication connection to the AXC 1050 (XC) (PROFINET device) or the function of the PROFINET device is switched off.
			On	No PROFINET communication (no link status at the Ethernet interfaces).
Flashing (1 Hz)	Link status present, no communication connection to the PROFINET controller.			

AXC 1050 (XC)

Table 3-1 Diagnostics and status indicators of the controller

Designation	Color	Meaning	State	Description
BF	Red	Status of PROFINET communication/communication errors	AXC 1050 (XC) concurrently operates as a PROFINET controller and device	
			Off	The AXC 1050 (XC) (PROFINET controller) has established an active communication connection to each configured PROFINET device and a PROFINET controller has established an active communication connection to the AXC 1050 (XC) (PROFINET device).
			On	No link status at the Ethernet interfaces and/or no 100-Mbit transmission and/or no full-duplex operation.
			Flashing (1 Hz)	Link status present, at least one configured PROFINET device has no communication connection or the PROFINET controller has no communication connection.
SF	Red	Group error (PROFINET)	Off	PROFINET diagnostics not present.
			On	PROFINET diagnostics present.
PLC: controller diagnostics				
RUN	Green	RUN status of the controller	Off	IEC 61131 runtime system not ready to operate.
			Flashing (0.5 Hz)	IEC 61131 runtime system successfully initialized. Control function is in the READY/STOP state, program not processed.
			Flashing (2 Hz)	Controller reset to default state (see Section "Reset button (concealed)" on page 30).
			On	IEC 61131 runtime system successfully initialized and a program is running. Control function is in the RUN state.
FAIL	Red	Failure	On	A runtime error has occurred in the IEC 61131 runtime system program.
			Off	No runtime error has occurred in the IEC 61131 runtime system program.
			Flashing (0.5 Hz)	The hardware watchdog of the controller has been triggered.
DBG	Yellow	Debug mode (troubleshooting)	On	The IEC 61131 runtime system/controller is in debug mode, i.e., debug mode has been activated in PC Worx (breakpoint(s) set and/or variable(s) forced). The state of the RUN LED is not affected.
			Flashing (2 Hz)	Boot phase of the controller (from sending the BootP request to assigning the IP address settings) if the MAC address of the controller has been entered in the PC Worx software. Otherwise, flashing stops after three failed boot requests.

Description of the AXC 1050 (XC)

Table 3-1 Diagnostics and status indicators of the controller

Designation	Color	Meaning	State	Description
AXC: Axioline F diagnostics				
D	Red/yellow/green	Axioline F: diagnostics for local bus communication	Green on	Run: The Axioline F station is ready for operation; communication within the Axioline F station is OK. All data is valid. There is no error.
			Flashing green	Active: The Axioline F station is ready for operation; communication within the Axioline F station is OK. The data is not valid. Valid data from the controller is not available. There is no malfunction in the device.
			Yellow on	Ready: The Axioline F station is ready for operation; no data is being exchanged.
			Flashing yellow	Access from Startup+ in I/O check mode
			Flashing yellow/red	Local bus error during active I/O check
			Flashing red	Local bus error during startup Possible causes: <ul style="list-style-type: none"> – Configuration cannot be generated, information is missing from a device – Chip version of a device is < V 1.1 – Deviation between actual and required configuration – No local bus device connected – The maximum number of local bus devices has been exceeded
			Red on	Bus error in RUN state The Axioline F station is ready for operation but has lost connection to at least one device. Possible causes: <ul style="list-style-type: none"> – Communication error – A local bus device has been removed or a configured device is missing – Reset from a local bus device – Serious device error at a local bus device (local bus device can no longer be reached)
Off	Power down: Device is in (power) reset.			
E	Yellow/red	Error/warning	Yellow on	I/O warning at an Axioline F device
			Red on	Peripheral fault at an Axioline F device

AXC 1050 (XC)

Table 3-1 Diagnostics and status indicators of the controller

Designation	Color	Meaning	State	Description
PWR: supply voltage (communications power U_L)				
UL	Green	U_{Logic}	Off	24 V communications power feed-in not present or too low.
			On	24 V communications power feed-in present.
ETH: Ethernet interfaces				
LNK	Green	Link status	Off	Connection not established successfully
			On	Connection established successfully (link): the controller is able to contact another network device.
			Flashing (0.5 Hz)	PROFINET device identification "flashing"
ACT	Yellow	Activity status	Off	Data transmission inactive
			On/flashing	Data transmission active (activity): the Ethernet interface is sending or receiving data

**Exception: updates**

During an update using FTP or an SD card, the RUN and DBG LEDs flash in alternation. For information about performing updates, please refer to Section "Performing updates" on page 150.

**Exception: update using an SD card**

Once an update using an SD card is successfully completed, the BF, SF, RUN und FAIL LEDs all flash concurrently at a frequency of 1 Hz. For information about performing updates using an SD card, please refer to Section "Performing updates via an SD card" on page 150.

3.6 Mode selector switch

The mode selector switch is used to define the operating state of the controller.

The RUN/PROG and STOP positions have a latching function and the MRESET position has a pushbutton function. After releasing the switch in the MRESET position, it returns to the STOP position.

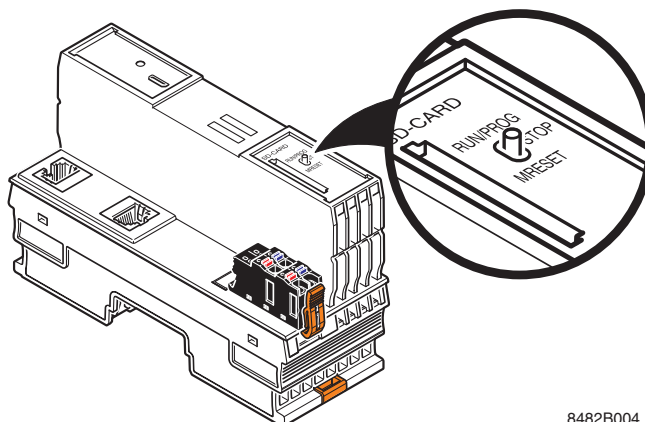

8482B004

Figure 3-8 Mode selector switch

Table 3-2 Controller operating modes

Operating mode	Description
RUN/PROG	<p>The controller is in the RUN state. The application program is being processed.</p> <p>The PC Worx (Express) software can be used for program and configuration modifications as well as for the online monitoring function.</p> <div style="border: 1px solid black; padding: 5px; margin-top: 10px;"> <p>i The application program is not processed if a controller error has occurred or if the application program has been stopped by PC Worx (Express).</p> </div>
STOP	<p>The controller is in the STOP state. Application program processing has been stopped.</p>
MRESET	<p>Retain data and the application program are deleted.</p> <p>Follow these steps to delete the retain data and the application program:</p> <ul style="list-style-type: none"> • Hold the mode selector switch in the MRESET position for three seconds. • Release the mode selector switch for fewer than three seconds. • Hold the mode selector switch in the MRESET position for three seconds.

3.7 Reset button (concealed)

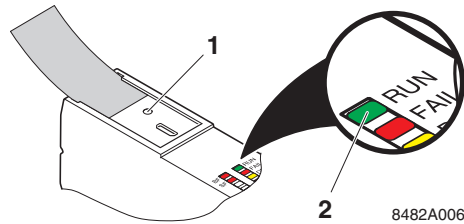

Figure 3-9 Reset button (1, concealed)

The reset button on the controller can only be operated with a pointed item (e.g., a pen) and is therefore protected against accidental activation.

If the reset button is actuated during operation, the controller is restarted. Furthermore, if you carry out a voltage reset concurrently as you press the reset button, this resets the controller to its default settings.

Resetting the controller to the default settings: procedure

- Switch off the supply voltage of the controller.
- After the LEDs have gone out press the reset button.
- Hold down the reset button and switch the supply voltage on. Release the reset button only after the RUN LED flashes quickly (item 2 in Figure 3-9).

The default settings are restored. Next the DBG LED flashes and the controller sends boot requests. The process has been completed once the RUN LED flashes slowly. The controller has been successfully initialized and reset to its default settings. The control function is in the READY/STOP state; a program is not processed. This process may take up to one minute, approximately.

3.8 Parameterization memory

The parameterization memory can be used to save programs and configurations (e.g., WebVisit projects, IP address of the controller, etc.) which belong to your PC Worx project. In addition, application-specific data can also be stored in the parameterization memory (see Section 7.3).

The controller has an integrated parameterization memory. Alternatively, it is possible to use a pluggable parameterization memory in the form of an SD card. The SD card is optional and not required to operate the controller.

**NOTE: Potential data loss**

If you remove the SD card during operation, this may result in a loss of data.

- Do not remove the SD card during operation.

**NOTE: Damaging the SD card after formatting**

The SD card is already formatted and is intended for use with Phoenix Contact devices. When you format the SD card, certain information on the SD card that is required for use with Phoenix Contact devices is lost. After formatting, you can no longer use the SD card to operate the controller.

- Make sure that the SD card is not formatted.



The SD card is recognized during initialization of the controller.

- Make sure that the SD card has been inserted before switching on the controller to enable the controller to use it.
- Only insert and remove the SD card when the controller supply voltage is disconnected.
- Only use an SD card provided by Phoenix Contact (for ordering data, see Section "Accessories" on page 148).



For additional information on the parameterization memory, please refer to Section 7.3.

3.9 Internal basic circuit diagram

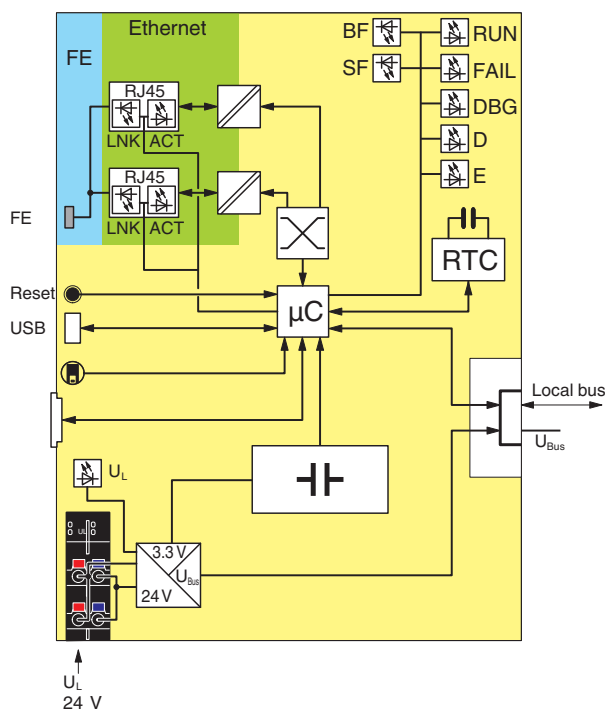

Figure 3-10 Internal basic circuit diagram (AXC 1050 (XC))

Key:

	Microprocessor		Transmitter
	UPS		LED
	Service interface (Micro-USB type B)		Real-time clock
	Reset button		Power supply unit
	RJ45 interface		Ethernet switch
	Functional earth ground connection		Mode selector switch
	SD card holder		Axioline F local bus

The colored areas in the basic circuit diagram represent electrically isolated areas:

- Logic
- Ethernet interface
- Functional earth ground

3.10 Communication paths

The following communication paths are available on the controller (see Figure 3-11):

- (1) 2 x Ethernet X1/X2: 10/100Base-T(X) (switched internally)
- (2) Service interface (Micro-USB type B) A free USB interface on your PC is connected directly to the controller.



For additional information on using the service interface (e.g., IP address assignment), please refer to Section 3.10.2.

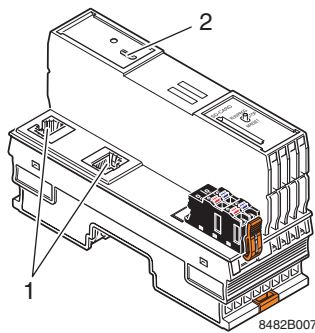

Figure 3-11 Communication paths: (1) Ethernet, (2) service interface (Micro-USB type B)

3.10.1 Ethernet

Two Ethernet interfaces (X1/X2) are available on the controller for connecting the Ethernet network.

The Ethernet network is connected via RJ45 sockets.



- Use an Ethernet cable which corresponds to CAT5 of IEEE 802.3 at least.
- Observe the bending radii of the Ethernet cables used.

The contact assignment of the interface is as follows:

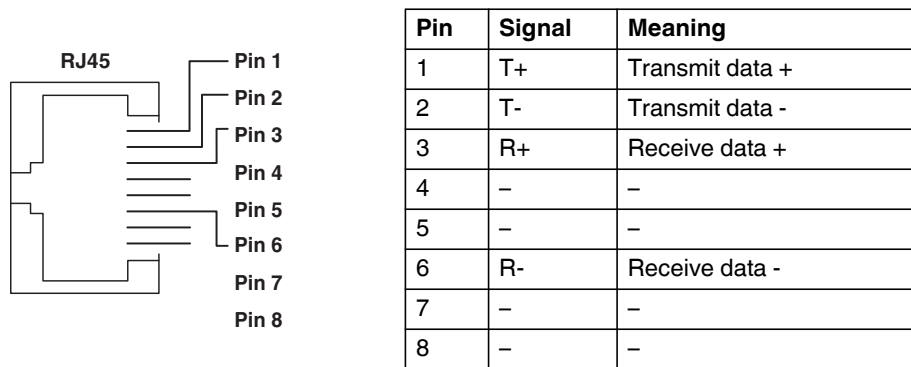

Figure 3-12 Ethernet interface and pin assignment



The Ethernet interfaces are able to switch over the transmitter and receiver automatically (auto crossover).

3.10.2 Service interface (Micro-USB type B)



In order to use the service interface of the controller, the "Phoenix Contact USB to UART Interface" driver must be installed (see Section Section 6.1).

In addition to providing the Ethernet interface, the service interface enables communication with the controller from a PC. Via the interface you can, for example, assign the IP address of the controller using the PC Worx software, access the controller using the Diag+ software or configure an Axioline F station using the Startup+ software.



The controller cannot be programmed via the service interface.

A connecting cable is required for direct connection of the PC Worx controller to a PC via the service interface.



Ordering data:
Connecting cable for connecting the controller to a PC with PC Worx, 2 m in length (CAB-USB A/MICRO USB B/2,0M, Order No. 2701626).

The service interface (2) is located beneath the marking field (1) on the controller.

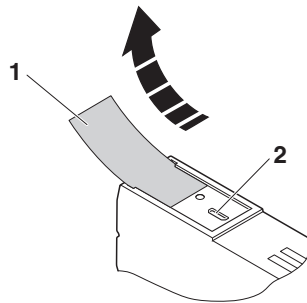

Figure 3-13 Service interface

3.11 Supply plug



Figure 3-14 Terminal points for the supply voltage (communications power U_L)

Terminal point assignment

Table 3-3 Terminal point assignment of the supply connector

Terminal point	Color	Assignment
a1, a2	Red	24 V DC (U_L)
b1, b2	Blue	GND

Key:

- U_L Communications power feed-in (internally jumpered)
- GND Reference potential of the supply voltage (internally jumpered)

3.12 Bus base module

Bus base modules carry the communications power and the bus signals from the controller through the Axioline F station (local bus). A bus base module is supplied with the controller.

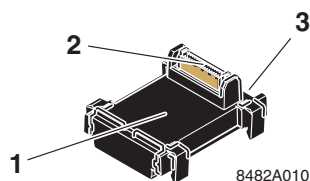

Figure 3-15 Structure of the bus base module of the controller

- 1 Bus base module
- 2 Connection of the local bus to the controller (socket)
- 3 Connection to the following bus base module (socket)

4 Mounting hardware



For basic information about the Axioline F system and its installation, particularly mounting/removing Axioline F modules, please refer to the UM EN AXL F SYS INST user manual ("Axioline F: system and installation").

4.1 Safety notes



NOTE: Electrostatic discharge!

The device contains components that can be damaged or destroyed by electrostatic discharge. When handling the device, observe the necessary safety precautions against electrostatic discharge (ESD) according to EN 61340-5-1 and IEC 61340-5-1.



NOTE: Electrical damage due to inadequate external protection – no safe fuse trip in the event of an error

The electronics in the device are damaged due to inadequate external protection.

- Protect the supply voltage externally in accordance with the connected load (number of Axioline F devices/amount of logic current consumption for each device).
- Make sure the external fuse blows safely in the event of an error.



NOTE: Damage to the contacts when tilting

If the controller/modules tilt, you can damage the contacts.

- Place the modules onto the DIN rail **vertically** (see Figure 4-1).



Please note:

- During all work on the Axioline F station, the controller or a module, switch off the power supply to the Axioline F station and make sure the supply voltage is protected against unauthorized re-activation.



The controller is automatically grounded (FE) when it is snapped onto a grounded DIN rail.

On the back of the controller there are two FE springs that make contact with the DIN rail when the controller is placed on the DIN rail.

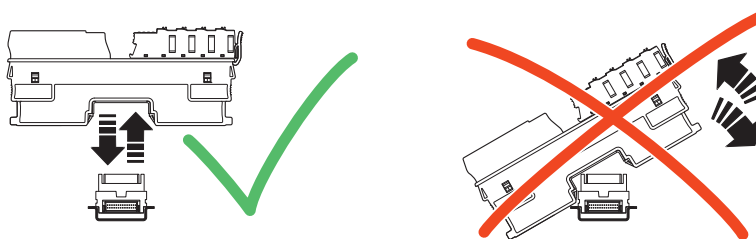

Figure 4-1 Placing the module **vertically**

AXC 1050 (XC)**4.2 Basics****Mounting location**

The controller fulfills the IP20 degree of protection and is designed for use in closed control cabinets or control boxes (terminal boxes) with IP54 degree of protection or higher.

Mounting on a DIN rail

The controller is mounted on a 35 mm standard DIN rail without any tools using the bus base module. The controller is mounted perpendicular to the DIN rail. The local bus is created automatically when the bus base modules of the controller and Axioline F devices are installed next to one another.



Observe the notes on securing the DIN rail and fastening elements, and the notes on mounting distances in the UM EN AXL F SYS INST user manual.

Supply plug

The controller has a supply plug for connecting the power supply. The plug has spring-cage terminal blocks. With suitable conductors, the conductor can be connected using the direct connection technology (PIT = push-in technology).



For additional information, please refer to Section 5.1.2 in the "Solid cable/ferrule" section.

FE connection

On the bottom of the controller there are two FE springs (metal contacts). The functional earth ground is connected via two FE springs when it snaps onto the grounded DIN rail. In addition, the controller has an FE tab via which functional earth ground can be connected if necessary.

Functional earth ground connection via the FE tab is only to be used to safely discharge interference in harsh environments where the DIN rail may be contaminated and the normal FE contacts no longer function correctly. For additional information on the grounding concept, please refer to the UM EN AXL F SYS INST user manual.

End brackets

Mount end brackets on both sides of the Axioline F station. They ensure that the Axioline F station is correctly mounted. End brackets secure the station on both sides and keep it from moving from side to side on the DIN rail. Phoenix Contact recommends using the following end brackets:

Table 4-1 Recommended end brackets

Mounting position	Ambient conditions	End bracket
Horizontal; A in Figure 4-2 on page 39	Normal	CLIPFIX 35, CLIPFIX 35-5
	High shock and vibration load	E/AL-NS 35
Other; B in Figure 4-2 on page 39	Normal	E/AL-NS 35
	High shock and vibration load	

Mounting position

As standard, mount the controller in a horizontal position on the DIN rail provided for that purpose (A in Figure 4-2).

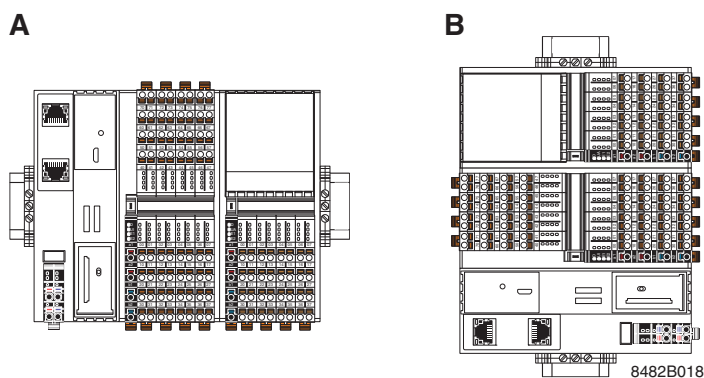

Figure 4-2 Horizontal (A) and vertical (B) mounting position

Other mounting positions are possible, however, derating may be required (see Section A 2, "Derating for the controller AXC 1050 XC").

Note the ambient temperatures and any other special features (e.g., derating) specified in the device/module-specific documentation for the Axioline F devices.

AXC 1050 (XC)

4.3 Structure of an Axioline F station

Figure 4-3 shows an example structure of an Axioline F station:

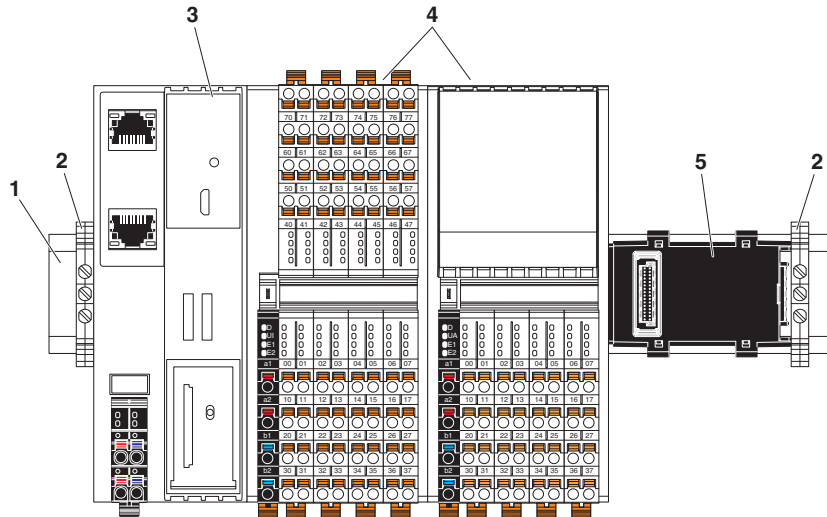

Figure 4-3 Structure of an Axioline F station with AXC 1050 controller

Key:

- 1 DIN rail
- 2 End bracket (e.g., CLIPFIX 35-5; Order No. 3022276)
- 3 AXC 1050 controller
- 4 I/O modules (Axioline F devices) corresponding to the application
- 5 Bus base module

An Axioline F station is set up by mounting the individual components side by side. No tools are required. Mounting the components side by side automatically creates potential and bus signal connections between the individual components of the Axioline F station.

4.4 Mounting the controller

Mounting bus base modules

- Disconnect the power to the Axioline F station.
- Mount the left end bracket on the Axioline F station.
- First install the bus base module for the controller and then all bus base modules necessary for the Axioline F station on the DIN rail (A in Figure 4-4).
- Push each subsequent bus base module into the connection of the previous bus base module (B in Figure 4-4).

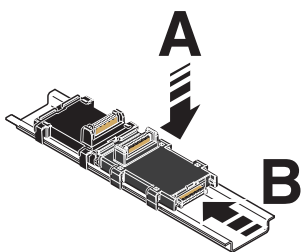

Figure 4-4 Mounting the bus base modules

Snapping on the controller

- Place the controller vertically on the first bus base module until it snaps into place with a click. Make sure that the device plug for the bus base connection is situated above the corresponding socket on the bus base module.

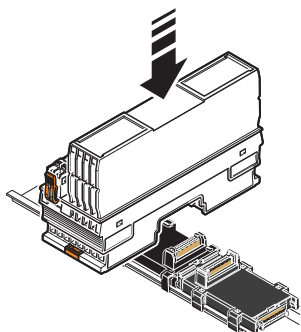

Figure 4-5 Snapping on the controller

4.5 Inserting the SD card

The controller has an SD card holder with push/push technology.

- Gently push the SD card into the SD card holder until it engages with a click in the SD card holder.

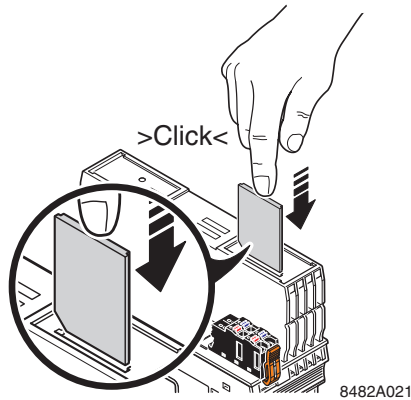

Figure 4-6 Inserting the SD card

5 Connecting and wiring hardware

5.1 Supply voltage

5.1.1 Sizing of the power supply

- Choose a power supply unit that is suitable for the currents in your application. The selection depends on the bus configuration and the resulting maximum currents.



A **power supply without a fall-back characteristic curve** must be used for correct operation of the controller (see Figure 5-2).

When the controller is switched on, an increased inrush current is temporarily triggered. The controller behaves like a capacitive load when it is switched on.



WARNING: Loss of electrical safety when using unsuitable power supplies

The controller is designed exclusively for protective extra-low voltage (PELV) operation according to EN 60204-1. Only PELV according to the defined standard may be used for supply purposes.

The following applies to the network (PROFINET) and the I/O devices used in it:

- Only use power supply units that meet EN 61204 with safe isolation and PELV according to EN 50178 or EN 61010-2-201.

This prevents short circuits between primary and secondary sides.

Some electronically controlled power supplies have a fall-back characteristic curve (see Figure 5-1). They are not suitable for operation with capacitive loads.

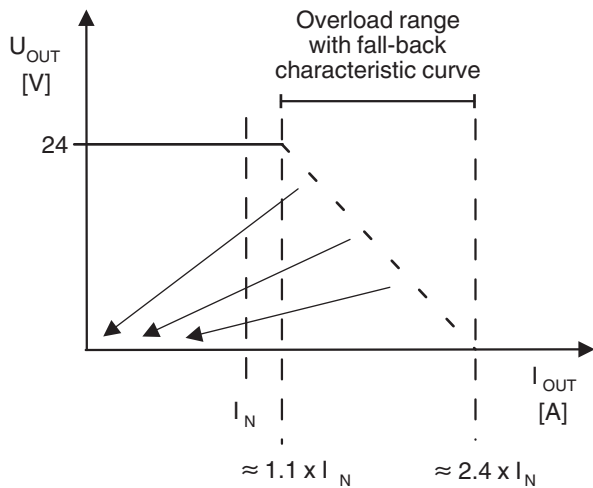

6219B070

Figure 5-1 Overload range **with** fall-back characteristic curve

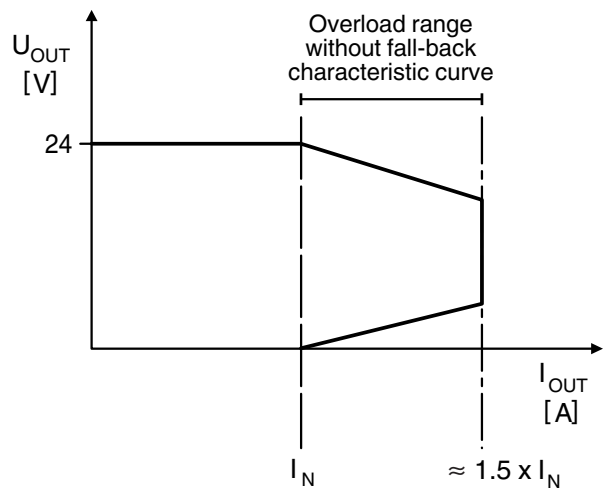

6219B071

Figure 5-2 Overload range **without** fall-back characteristic curve

5.1.2 Connecting the power supply

Observe the notes in Section 3.11 when assembling the plug for the supply voltage.

- Strip 8 mm off the cable.
- Fit a ferrule to the cable, if required.



If you are using ferrules, use them in accordance with the specifications in the UM EN AXL F SYS INST user manual.

- Make sure the ferrules are properly crimped.

Solid cable/ferrule

- Insert the cable into the terminal point. The wire is clamped automatically.



Figure 5-3 Connecting a solid cable

Stranded cable

- Open the spring by pressing on the spring lever with a screwdriver (A in Figure 5-4).
- Insert the cable into the terminal point (B in Figure 5-4).
- Remove the screwdriver to fasten the cable (recommended: bladed screwdriver, blade width of 2.5 mm (e.g., SZS 0.4x2.5 VDE, Order No. 1205037)).

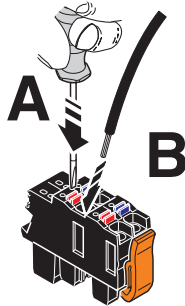

Figure 5-4 Connecting a stranded cable

Connecting the supply plug

- Place the supply plug vertically into its position and press firmly. Make sure that the locking latch snaps in.

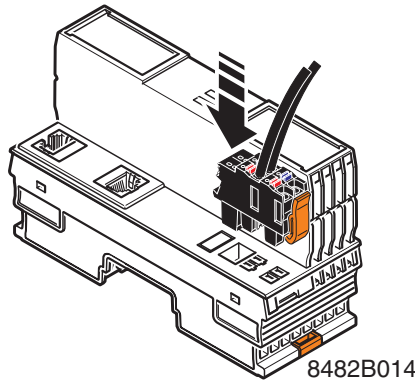

Figure 5-5 Connecting the supply plug

Supply the controller using external 24 V DC voltage sources. The permissible voltage range is from 19.2 V DC to 30 V DC (ripple included). The power consumption of the controller at 24 V is typically 3 W (no local bus devices connected).



Only use power supplies that are suitable for operation with capacitive loads (increased inrush current) (see Section 5.1.1).

- Connect the power supplies to the supply plug as shown in Figure 5-5. Please observe the information in Section 3.11.
- Switch on the power supplies.
- Behavior of the device LEDs when switching on for the first time (default setting):
 - The UL LED lights up. The FAIL LED flashes briefly then the DBG LED flashes for around 30 seconds. Then the D LED is permanently on and the RUN LED starts flashing.
 - If the controller is connected to the PC Worx software online, and you have entered the MAC address of the controller in the "IP Settings" tab in the "Device Details" window and the BootP server is also activated in PC Worx, the DBG LED will only flash for around 10 seconds. Then the D LED is permanently on and the RUN LED starts flashing.
- Behavior of the device LEDs when a program is present on the controller and the IP address settings have been assigned:

The FAIL LED lights up briefly then the DBG LED starts flashing. When the controller starts up without errors, the DBG LED goes out after around 30 seconds and the RUN and D LEDs are permanently on.

The controller is now fully initialized.

If the LEDs do not light up or start flashing, there is a serious fault on the controller.

- In this case, please contact Phoenix Contact.

5.2 Connecting Ethernet

- Connect the Ethernet network to the RJ45 sockets.

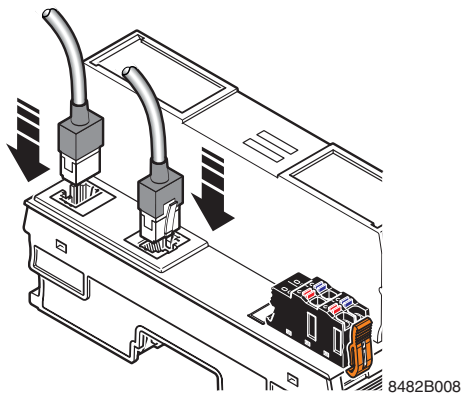

Figure 5-6 Connecting Ethernet

5.3 Connecting USB cable

- Make sure that the controller is supplied with power (see Section "Connecting the power supply" on page 44) and in the RUN operating state.
- Connect the connecting cable to the service interface of the controller (X4 designation, see Section 3.4) and to a free USB interface of the PC.

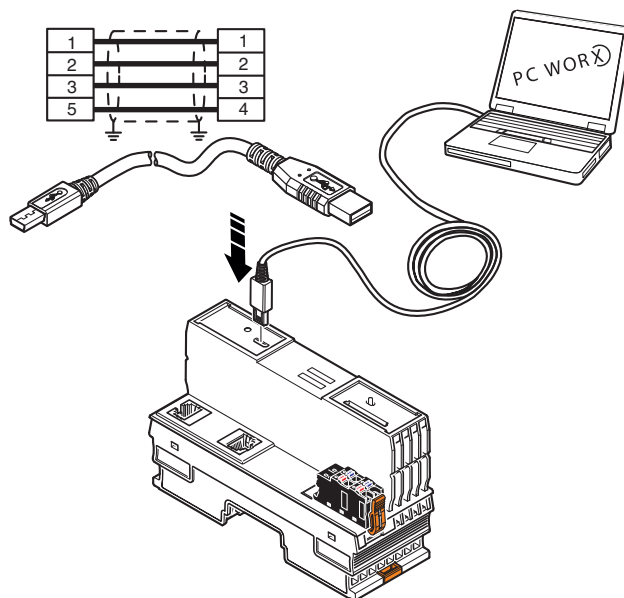

Figure 5-7 Connecting cable between PC and controller

6 Startup

You must have the PC Worx (Express) software to start up the controller (Version 6.30 or later, which is part of AUTOMATIONWORX Software Suite 2017 Version 1.84).

6.1 Installing PC Worx (Express)

The software is available to download at phoenixcontact.net/products.

- Download the software onto your computer.
- Double-click on the *.exe file to start installation.
- Follow the instructions of the installation wizard.

USB driver

The "Phoenix Contact USB to UART Interface" USB driver must be selected explicitly when installing the AUTOMATIONWORX Software Suite (see Figure 6-1). This is the only way to ensure that the AXC 1050 (XC) will be detected as a USB device under Windows®.

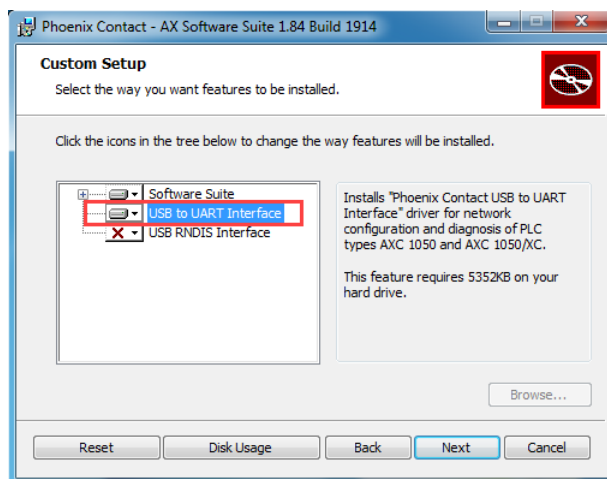

Figure 6-1 Selecting the USB driver

If, after installation, the AXC 1050 (XC) is not automatically detected as a USB device under Windows®, repeat the installation process and make sure that the "USB to UART Interface" USB driver is selected.



PC Worx (Express) – installation and use

For information on installing and using PC Worx (Express), please refer to the respective corresponding quick start guide. The documents are contained in the installation package for the software. In addition, the documents can be downloaded at phoenixcontact.net/products.

6.2 Creating a new project

Before you can configure the settings described in the following sections, you have to create a new project in the software.

- In the "New Project" dialog, select the "AXC 1050 ..." template according to the version of the controller you are using.
- Save the project using an appropriate name (in the example: "UM_AXC_1050").



PC Worx (Express) – online help and quick start guide

For general information on PC Worx (Express), refer to the online help and/or the quick start guide.

Project name	Value
Project name	UM_AXC_1050
Creator	
Computer name at project creation	PXCSW-N0082
MULTIPROG version at project creation	5.51.8.0
PC WORX version at project creation	PC WORX 6.30.1503
Creation date	2015-09-22T08:46:08+01:00
Last editor	
Computer name at last project backup	PXCE-V0115
MULTIPROG version at last project backup	5.51.198.0
PC WORX version at last project backup	PC WORX 6.30.1820
Date of last project backup	2016-11-15T12:33:57+01:00
Domain Postfix	
Template for DNS name creation	
First IP Address	172.16.120.2
Last IP-Address	172.16.120.254
Subnetmask	255.255.255.0
Default Gateway	
Use DHCP	No
Subnet Check for Multi MAC Devices	On
Certificate information	
Organization	PHOENIX CONTACT GmbH & Co. KG
Organizational Unit	
Locality	Blomberg
State or Province	Nordrhein-Westfalen
Country	DE

Figure 6-2 Project information after creating a new project

6.3 Assigning the IP address for the controller

By default, the controller has no preset IP address. Initial setting of the IP address can be carried out with the PC Worx (Express)/ software manually via the USB interface, via the Discovery and basic Configuration Protocol (DCP) or by means of a BootP server. Following this, it is possible to change the IP address using the same methods. In addition, you can assign the controller another IP address in PC Worx (Express) using the network settings in the "Extended Settings" tab.

6.3.1 Discovery and basic Configuration Protocol (DCP)

In a PROFINET system, PROFINET devices can be assigned PROFINET names and IP addresses using the Discovery and basic Configuration Protocol.



The controller from firmware version 2.10 or later and from PC Worx / PC Worx Express version 6.30 or later (part of the AUTOMATIONWORX Software Suite 1.82) supports the Discovery and basic Configuration Protocol (DCP).



IP address assignment not possible

You cannot assign the IP address via DCP if:

- The controller is being used as a PROFINET controller and an active application relation (AR) exists.
- The controller is being used as a PROFINET device and an active application relation (AR) exists.
- The function "PROFINET device activated / PROFINET controller activated" is activated.

You can find information on the PROFINET controller and device function in Section 6.5.



Note on IP address settings

PC Worx (Express) assigns an IP address range automatically when a project is created. This will be displayed in the "Project" tab in the "Device Details" window if you have selected the project name in the "Bus Structure" window (see Figure 6-2).

The "IP Settings" tab in the "Device Details" window will display the relevant IP address settings for the controller (see Figure 6-3 on page 50) if you have selected the controller in the "Bus Structure" window. You can assign these settings to the controller via the Discovery and basic Configuration Protocol (DCP) if you select the relevant functions in the "IP Assignment" tab (see Figure 6-4 on page 51).

- Adapt the IP address settings to your application, if necessary.

AXC 1050 (XC)



The IP address is assigned via DCP in the PC Worx (Express) software, in the "IP Settings" tab in the "Device Details" window.

- Open the Bus Configuration Workspace.
- Select the controller in the "Bus Structure" window.
- In the "Device Details" window, switch to the "IP Settings" tab (see Figure 6-3).
- Check the displayed IP address settings.
- Adapt the IP address settings if necessary.

Name	Value
Vendor	Phoenix Contact
Designation	AXC 1050
Functional description	Axioline Controller for Ethernet Networks
Device type	PLC
Device family	AXC1xxx
Order number	2700988
Revision	01/3.00
Station Name	
Device Name	
Module Equipment ID	
DNS Name	axc-10501
MAC Address	
IP Address	172.16.120.31
Subnetmask	255.255.255.0
Default Gateway	

Figure 6-3 IP address settings of the controller (AXC 1050)

- Switch to the "IP Assignment" tab (see Figure 6-4).

The PROFINET network is then searched for DCP devices.

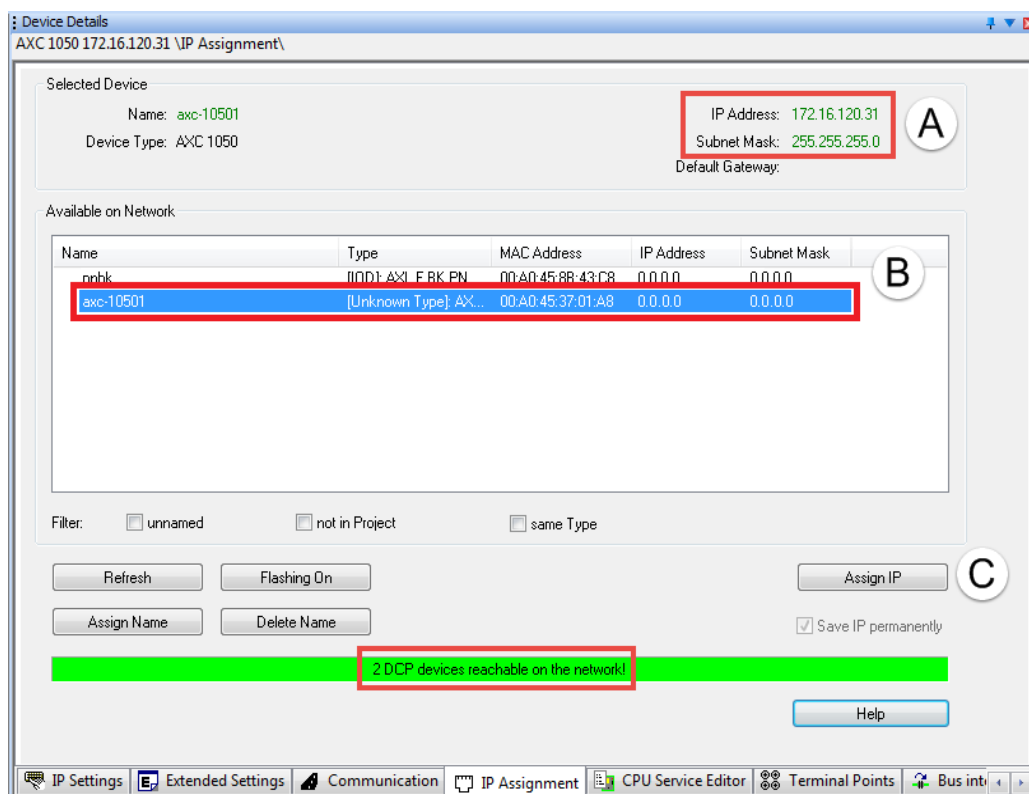

Figure 6-4 "IP Assignment" dialog: DCP devices are accessible in the network

The accessible DCP devices are displayed in the "Device Details" window.

- Select the device to which you want to assign the displayed IP address settings (A).
- Click the "Assign IP" button (C) to automatically assign the displayed IP address settings (A) to the selected device (B).

If you have not selected a device from the list, the software will notify you of this.

The successful IP address assignment is displayed in the "Device Details" window (see A and B in Figure 6-5).

AXC 1050 (XC)

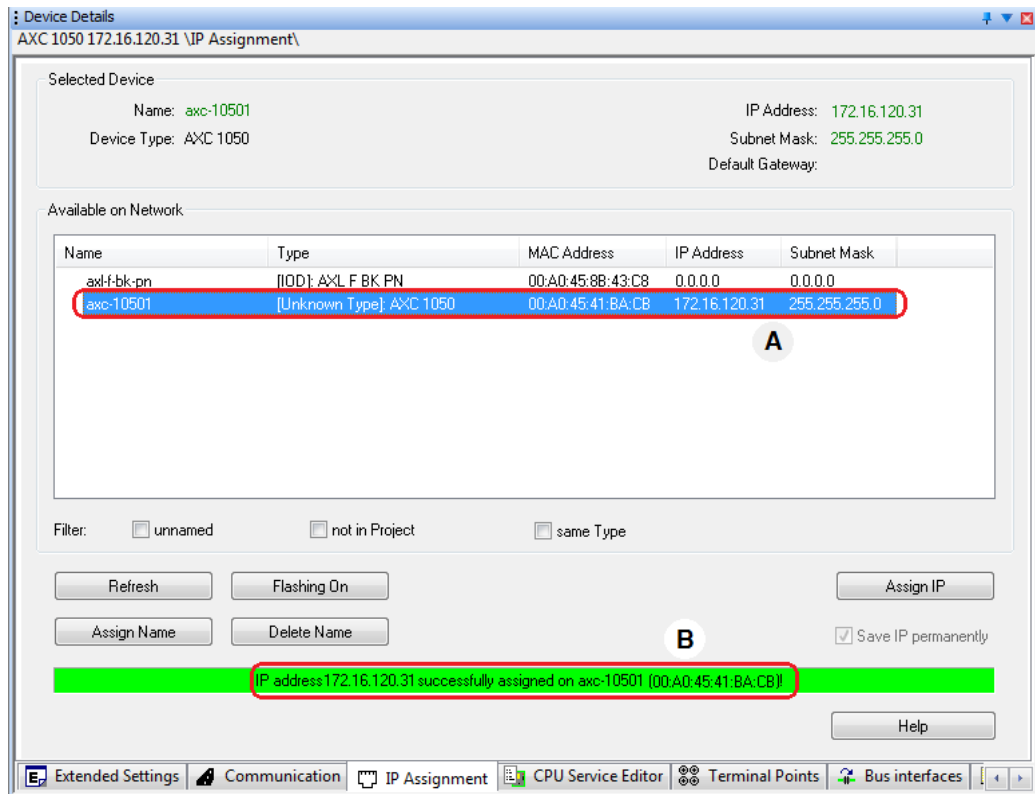

Figure 6-5 "IP Assignment" dialog: assigning an IP address to a DCP device

The PROFINET name is assigned in a similar way.

6.3.2 BootP server

Bootstrap Protocol (BootP)

The controller supports the Bootstrap Protocol (BootP). The AXC 1050 (BootP client) sends a boot request (broadcast) to the network. PC Worx (Express) responds with a boot reply that contains the IP address and subnet mask of the controller. The requirements are as follows:

- The BootP server knows the MAC address sent by the BootP client.
- A corresponding IP address and subnet mask have been assigned in PC Worx (Express) for the MAC address.

Once the IP data has been transferred to the AXC 1050 successfully, PC Worx (Express) sends a corresponding acknowledgment message.



Communication path and IP addresses/BootP

Please note:

- BootP is active by default on the controller.
- The IP address that is assigned here for the controller via BootP is also applied as the IP address for the communication path via TCP/IP.
- After assigning the IP address, PC Worx (Express) automatically sets the connection via TCP/IP as the communication path to the controller.

PC/network adapter

To determine whether your network permits the IP settings used, you must proceed as follows:

- In the Windows® Control Panel, check the settings for your PC network adapter.
- If necessary, adjust these settings so that the AXC 1050 can be accessed in your network via the IP address used.
- If your network does not permit the use of the IP address used, adjust the settings in the project information accordingly (see Figure 6-2 on page 48).



If any modifications are made to the project information that affect the IP settings for the controller, these are indicated in a warning (see Figure 6-2 on page 48). However, the modification is not applied automatically. When a new project is created, the default settings are specified in the "IP Settings" tab (see Figure 6-6).

Activating BootP

BootP is active by default on the controller.

If you have already assigned the IP address via DCP or manually and want to change the IP address again via BootP, you first have to activate BootP. To do this, proceed as follows:

- Open the Bus Configuration Workspace.
- Select the controller in the "Bus Structure" window (in the example: "AXC 1050").
- In the "Device Details" window, switch to the "Extended Settings" tab.
- Select "Usage of a BootP Server" in the network settings.
- Click on the "Send" button to send the setting to the controller.
- In the "Settings Communication Path" dialog box, confirm the suggested IP address or the one you have set according to your application with "OK".
- Successful execution of the service is displayed in the status window.

Entering the MAC and IP addresses

Proceed as follows to enter the MAC and IP addresses:

- In the "Device Details" window, select the "IP Settings" tab.
- Enter the MAC address of the controller (see Figure 6-6). It is imprinted on the device (see item 1 in Figure 6-6). It starts with "00.A0.45".
- Enter the IP address to be assigned to the controller.
- Enter the subnet mask.

Name	Value
Vendor	Phoenix Contact
Designation	AXC 1050
Functional description	Axioline Controller for Ethernet Networks
Device type	PLC
Device family	AXC1xxx
Order number	2700988
Revision	01/3.00
Station Name	
Device Name	
Module Equipment ID	
DNS Name	axc-10501
MAC Address	00-A0-45-37-01-A8
IP Address	172.16.120.31
Subnetmask	255.255.255.0
Default Gateway	

Figure 6-6 Entering IP address settings

AXC 1050 (XC)

Establishing a connection • Connect the controller with your PC via an Ethernet cable.

Activating BootP • In the PC Worx (Express) menu bar, select the "Extras, BootP/SNMP/TFTP-Configuration..." menu.

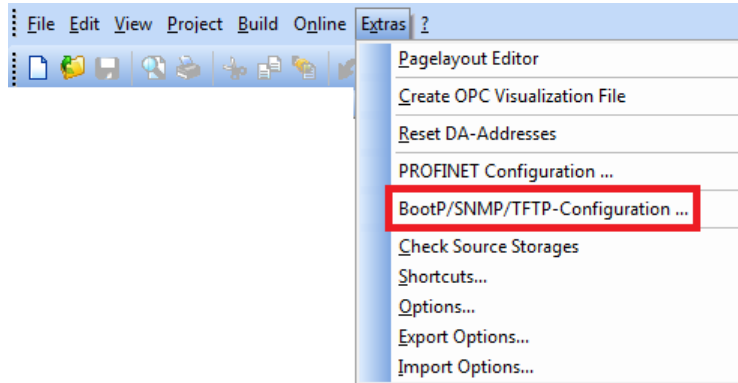
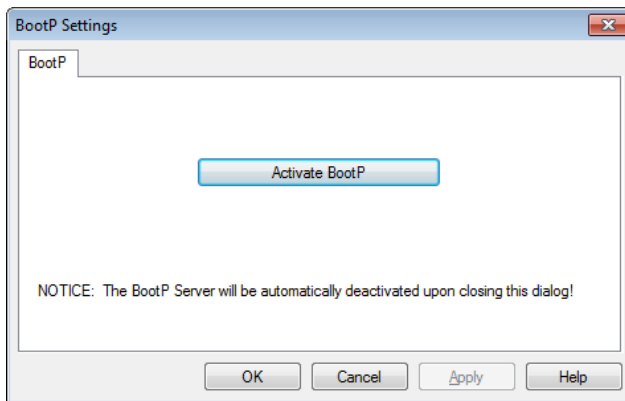

Figure 6-7 "Extras, BootP/SNMP/TFTP-Configuration..." menu

• Click on the "Activate BootP" button (A in Figure 6-8).

A



B

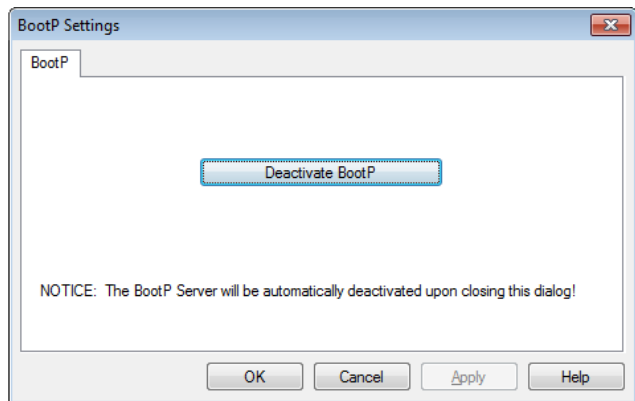

Figure 6-8 "Activate BootP" (A) and "Deactivate BootP" (B) buttons

Applying IP settings after a cold restart

• Perform a cold restart for the controller. To do this, switch the supply voltage off and then on again after about two seconds.

Applying IP settings without a cold restart

If you have activated the function that immediately applies the IP address (see Section 7.2), then it is not necessary to perform a cold restart (voltage reset) of the controller. This function is deactivated by default.

The controller is assigned the IP address that you entered in the "Device Details" window of the "IP Settings" tab (see Figure 6-6). The following message appears in the message window in the "Bus Configurator" tab:

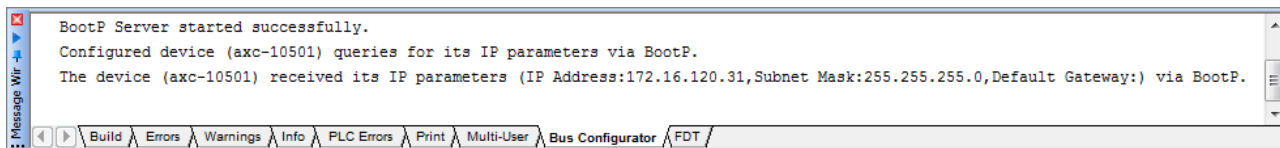

Figure 6-9 Message window following BootP

The IP address is now permanently stored in the controller's internal parameterization memory.



If you use the SD card as the main memory (see Section 6.8), the IP address settings are saved on the SD card.

Deactivate BootP

- Click the "Deactivate BootP" button to deactivate the BootP server (B in Figure 6-8 on page 54).

The shutdown is indicated in the Message Window (refer to Figure 6-9).

Testing network settings

Follow these steps to test the assigned network settings:

- Open the Bus Configuration Workspace.
- Select the controller in the "Bus Structure" window.
- In the "Device Details" window, select the "Communication" tab.
- Click the "Test" button to test the assigned network settings.

A successful communication test is indicated by the text "Host Type: AXC 1050" displayed with a green background.

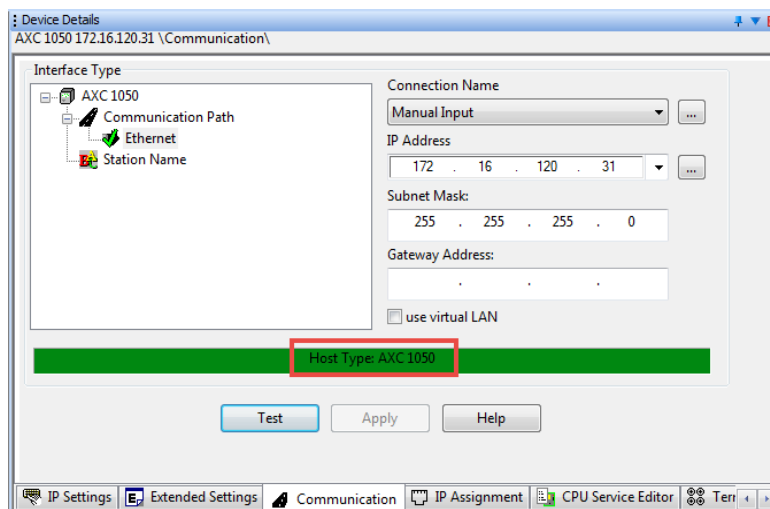

Figure 6-10 Successful communication path test

AXC 1050 (XC)

6.3.3 Assigning the IP address via the USB interface



The CAB-USB A/MICRO USB B/2.0 M USB connecting cable (Order No. 2701626) is available as an accessory for connecting the controller to a PC via the USB interface.



In order to use the USB interface of the AXC 1050 (XC), the "Phoenix Contact USB to UART Interface" driver must be installed; see Section 6.1 on page 47.

The advantage of assigning the IP address via the USB interface is that you do not have to change the network settings of your PC.

- Connect the controller with your PC using a USB cable.

If you selected to install the USB driver when installing the AUTOMATIONWORX Software Suite/PC Worx (see Figure 6-1), the PC will immediately detect the AXC 1050 (XC) as a USB device. No other settings are required.

Follow these steps to assign the IP address manually:



- Open the Bus Configuration Workspace.
- Select the controller in the "Bus Structure" window (in the example: "AXC 1050").
- Select the "Extended Settings" tab in the "Device Details" window.
- In the network settings, select "Manual definition of the TCP/IP settings".
- Enter the required IP address (in the example in Figure 6-11: IP address: 172.16.120.31; subnet mask: 255.255.255.0).

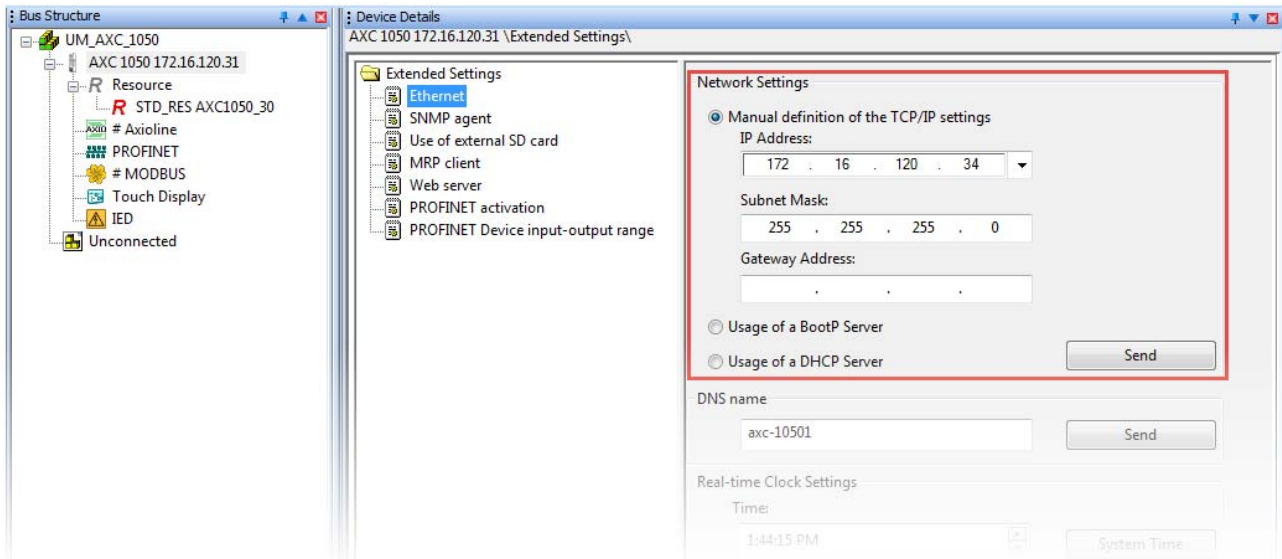

Figure 6-11 Network settings: "Manual definition of the TCP/IP settings"

Transmitting settings to the controller

- Click on the "Send" button.
- In the "Settings Communication Path" dialog box, select the USB interface and confirm with "OK".

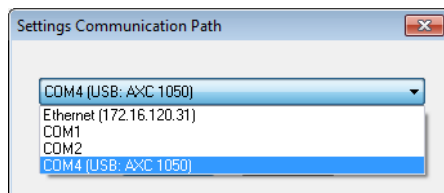

Figure 6-12 "Settings Communication Path" dialog box

Successful download of the IP address settings to the controller is displayed in the status window:

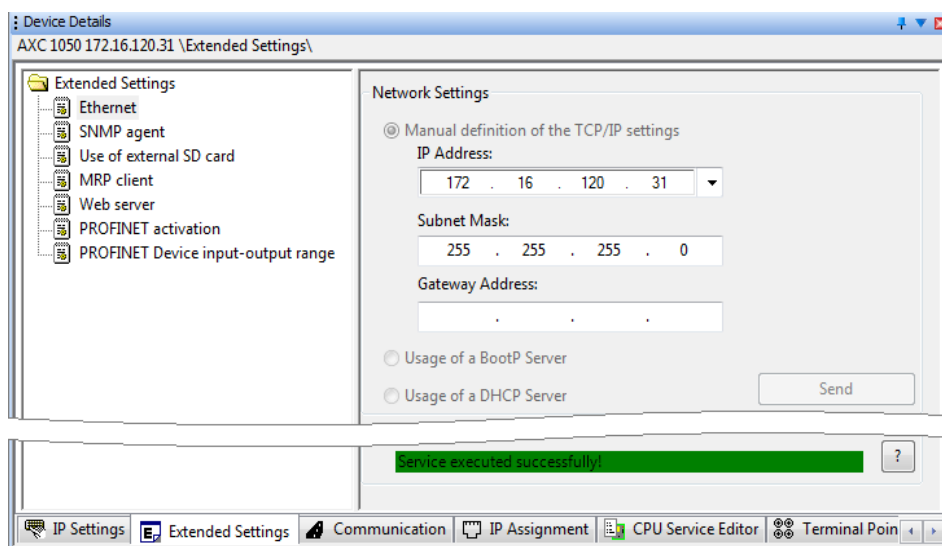

Figure 6-13 IP address settings download successful

Applying IP address settings after a restart

In order for the transferred IP address settings to take effect in the controller, you must restart the controller (voltage reset).

- In "Device Details", select the "Ethernet" setting under "Extended Settings".
- In the "Activate Network Settings" area, click on the "Restart Controller" button.

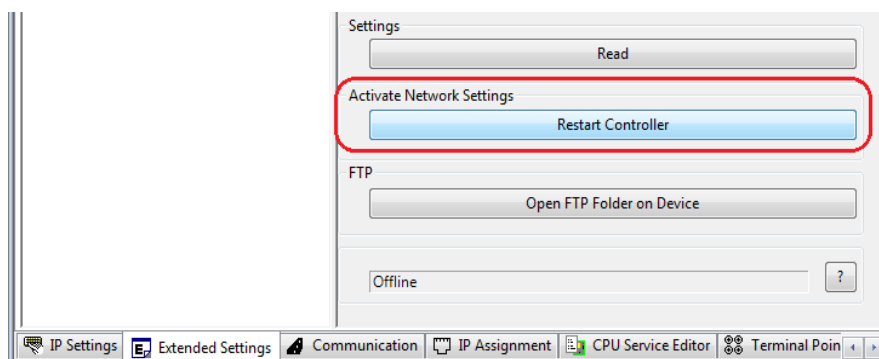

Figure 6-14 Activate Network Settings: Restart Controller

AXC 1050 (XC)

- If a prompt appears asking whether you really want to restart the controller, confirm the dialog with "Yes".
- In the "Settings Communication Path" dialog box, select the USB interface and confirm with "OK".

Successful execution of the service is displayed in the status window:

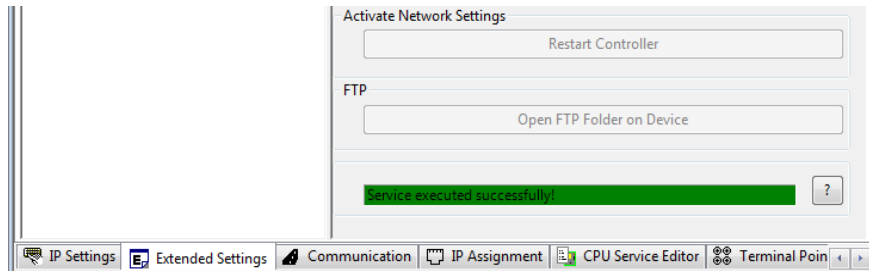

Figure 6-15 Activating the network settings: service executed successfully

Applying IP address settings without a restart

If you have activated the function that immediately applies the IP address (see Section "Applying the IP address immediately" on page 86), then it is not necessary to perform a restart (voltage reset) of the controller. This function is deactivated by default.

The IP address settings assigned to the AXC 1050 are now active.

Testing network settings

Follow these steps to test the assigned network settings:

- Open the Bus Configuration Workspace.
- Select the controller in the "Bus Structure" window.
- In the "Device Details" window, select the "Communication" tab.
- Click the "Test" button to test the assigned network settings.

A successful communication test is indicated by the text "Host Type: AXC 1050" displayed with a green background.

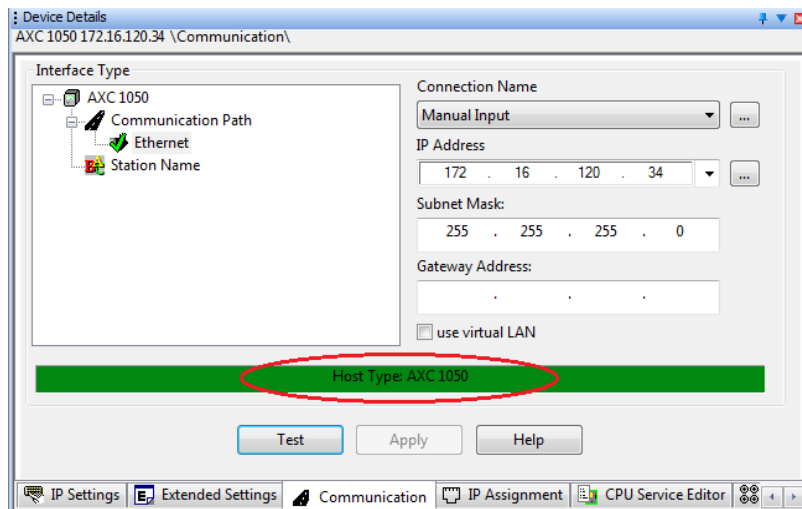

Figure 6-16 Successful communication path test

6.3.4 Dynamic Host Configuration Protocol (DHCP)

The controller supports the Dynamic Host Configuration Protocol (DHCP). DHCP enables IP address assignment via a DHCP server. To do this, the setting for IP address assignment via DHCP must be activated in PC Worx.



Please note:

The controller must already have a valid IP address so that you can activate the setting for IP address assignment via DHCP in PC Worx.

- Assign the controller an IP address via DCP, BootP or manually, as described in the Section 6.3.1 ... Section 6.3.3. sections.



Follow these steps to assign the controller a new IP address via a DHCP server:

- Open the Bus Configuration Workspace.
- Select the controller in the "Bus Structure" window.
- In the "Device Details" window, switch to the "Extended Settings" tab.
- Select "Usage of a DHCP Server" in the network settings.

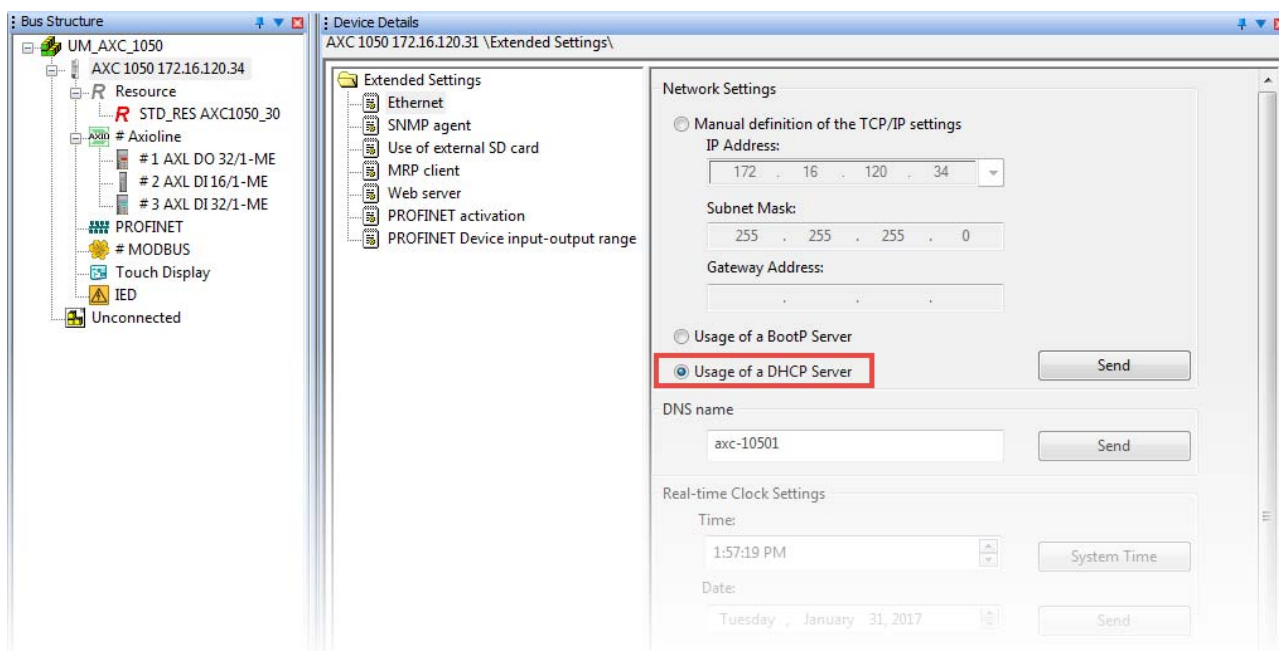

Figure 6-17 Network Settings: Activate DHCP

- Click on the "Send" button.
- In the "Settings Communication Path" dialog box, confirm the suggested IP address or the one you have set according to your application with "OK" to transfer the settings to the controller.

Successful execution of the service is displayed in the status window.

AXC 1050 (XC)

Restarting the controller

To apply the settings in the controller, the controller must be restarted.

- In the "Device Details" window, select the "Ethernet" setting under "Extended Settings".
- In the "Activate Network Settings" area, click on the "Restart Controller" button.
- If a prompt appears asking whether you really want to restart the controller, confirm the dialog with "Yes".
- In the "Settings Communication Path" dialog box, confirm the suggested IP address or the one you have set according to your application with "OK".

After restarting, the controller sends a DHCPDISCOVER message (broadcast) to all available DHCP servers in the network. Then, the controller selects one of the IP addresses offered by the DHCP servers.

The selected IP address is now assigned to the controller.



Please note:

The lease time is not supported by the controller. The assigned IP address is considered "valid without restrictions". To assign another IP address to the controller via DHCP, the controller must be restarted.

6.4 Reading Axioline F

- In the "Bus Structure" window, select "Axioline" below the controller.
- Right-click to open the context menu and select "Read Axioline".

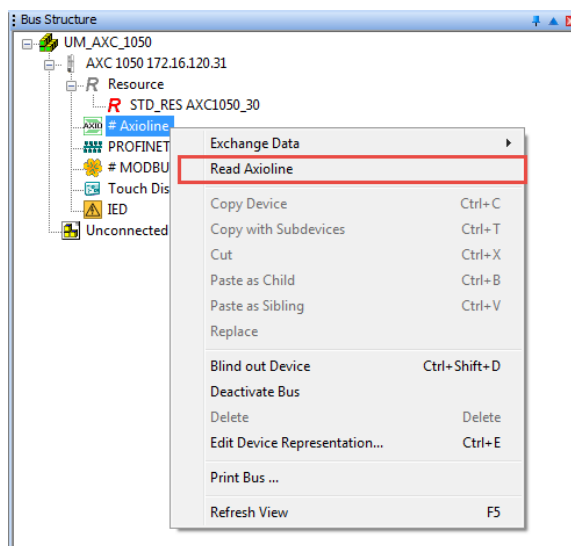

Figure 6-18 "Read Axioline" option

All Axioline F modules connected to the controller are displayed in the "Read Axioline" dialog that opens. Modules marked in black text have not yet been read into the PC Worx (Express) project; modules marked in green text have already been configured and remain unchanged even after another read process. When the "Re-insert all modules" check box is activated, modules that have already been configured are also read again. The previously configured bus structure is overwritten.

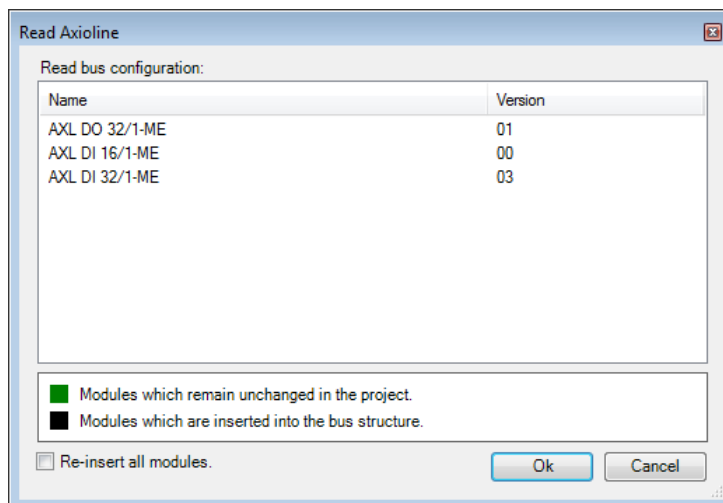
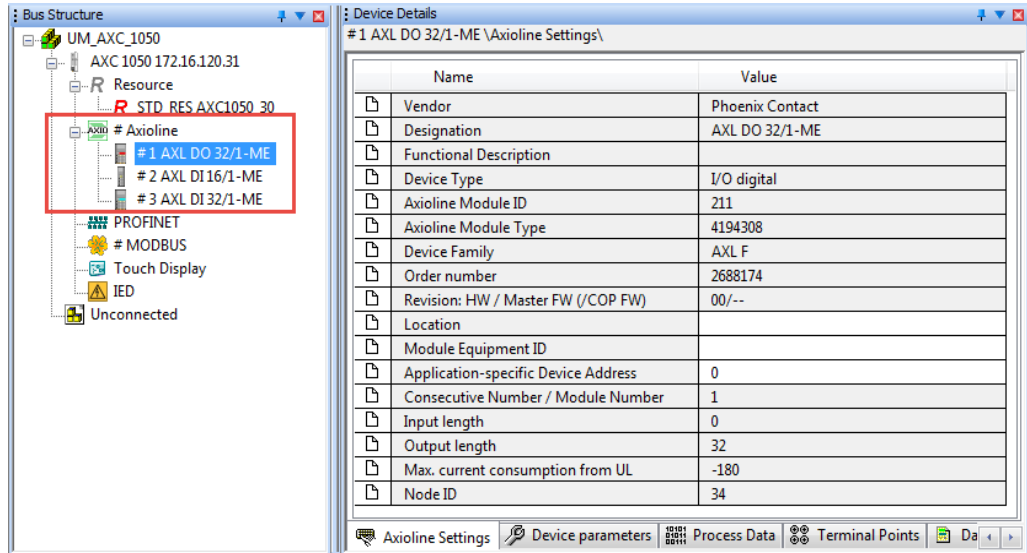

Figure 6-19 "Read Axioline" dialog: Axioline F modules that have not yet been read in

AXC 1050 (XC)

- Activate the "Re-insert all modules" check box.
- Select all connected Axioline F modules.
- Click the "OK" button to read in the selected Axioline F modules.
- Acknowledge the "Read Axioline – Do you want to delete all configured Axioline modules and accept the connected modules?" dialog to read in the connected Axioline F modules.

The read-in Axioline F devices are displayed in the "Bus Structure" window. If you select a device, the device details will be displayed.



The screenshot shows two windows from a software interface. The left window, titled "Bus Structure", displays a hierarchical tree of system components. Under the "Axioline" folder, three modules are listed: "# 1 AXL DO 32/1-ME", "# 2 AXL DI 16/1-ME", and "# 3 AXL DI 32/1-ME". The first module is highlighted with a blue selection bar. The right window, titled "Device Details", displays the configuration parameters for the selected module. The parameters are listed in a table with columns for "Name" and "Value".

Name	Value
Vendor	Phoenix Contact
Designation	AXL DO 32/1-ME
Functional Description	
Device Type	I/O digital
Axioline Module ID	211
Axioline Module Type	4194308
Device Family	AXL F
Order number	2688174
Revision: HW / Master FW (/COP FW)	00/--
Location	
Module Equipment ID	
Application-specific Device Address	0
Consecutive Number / Module Number	1
Input length	0
Output length	32
Max. current consumption from UL	-180
Node ID	34

Figure 6-20 Read-in Axioline F devices

6.5 The PROFINET controller/device function of the AXC 1050 (XC)



The PROFINET controller and device function of the controller is not supported by the PC Worx Express software.

If there is already an online connection between PC Worx Express and the controller, you can simply activate/deactivate the PROFINET controller function and/or the PROFINET device function. PROFINET networks cannot be configured in the PC Worx Express software.

This section covers the following topics:

- How to activate or deactivate the PROFINET controller/device function in PC Worx (Express).
- How to integrate the AXC 1050 (XC) into PC Worx as a PROFINET controller and/or PROFINET device.

6.5.1 Activating the PROFINET controller/device function



The PROFINET activation procedure is identical in PC Worx and PC Worx Express.

You can activate the PROFINET controller and/or PROFINET device function once you have assigned an IP address for the AXC 1050 (XC) as described in Section 6.3.

- In the "Device Details" window, select the "PROFINET activation" setting under "Extended Settings".
- In the "Settings" drop-down list, select one of the following entries: "PROFINET device activated" (in the example in Figure 6-21), "PROFINET controller activated" or "PROFINET device activated / PROFINET controller activated".

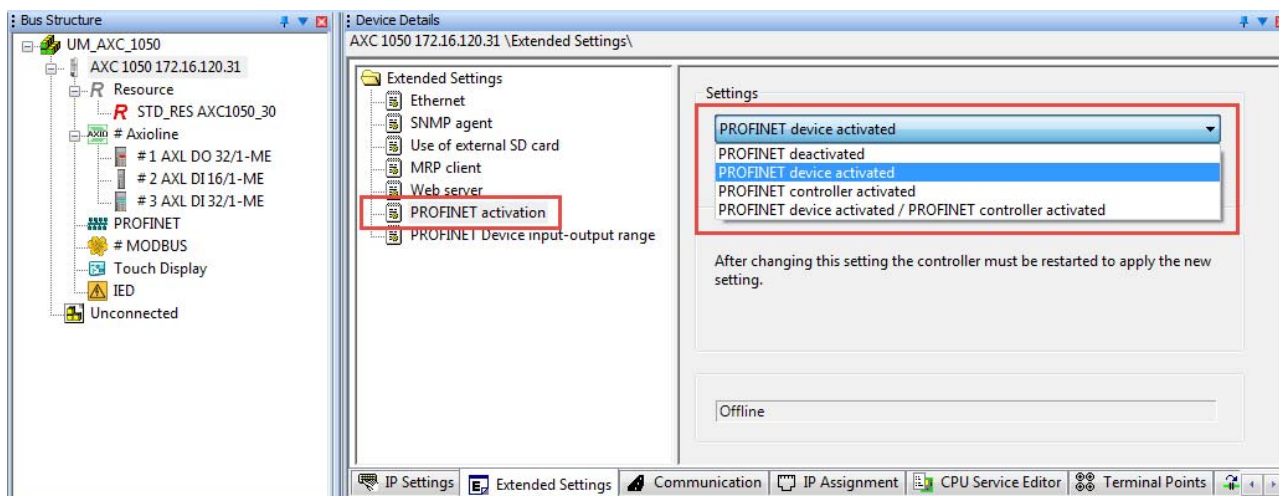

Figure 6-21 "Extended Settings, PROFINET activation: PROFINET device activated"

AXC 1050 (XC)

- Click on the "Send" button.

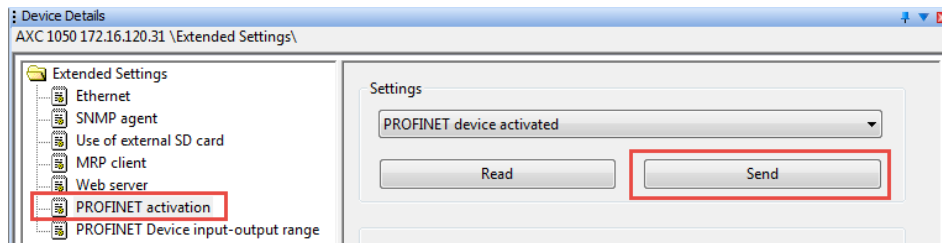

Figure 6-22 PROFINET activation: sending settings

- In the "Settings Communication Path" dialog box, confirm the suggested IP address or the one you have set according to your application with "OK".

Alternatively, you can also select the connection via the USB interface as the communication path if a USB connection exists between the controller and your PC.

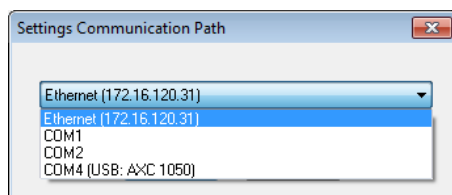

Figure 6-23 "Settings Communication Path" dialog

Successful execution of the service is displayed in the status window.

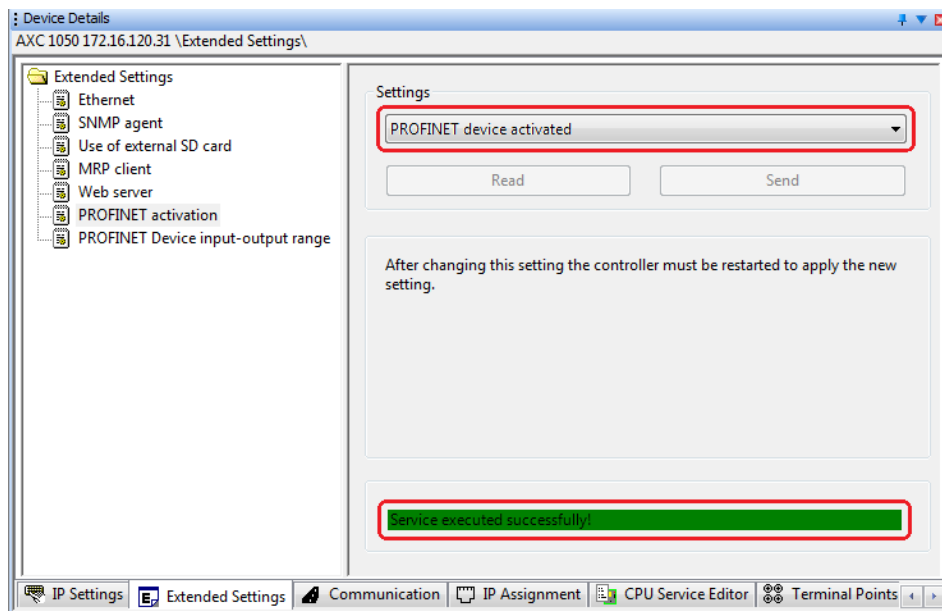

Figure 6-24 PROFINET activation: service successfully executed

Restarting the controller

In order for PROFINET activation (in this case: PROFINET device activated) to take effect in the controller, you must restart the controller.

- In the "Device Details" window, select the "Ethernet" setting under "Extended Settings".
- In the "Activate Network Settings" area, click on the "Restart Controller" button.

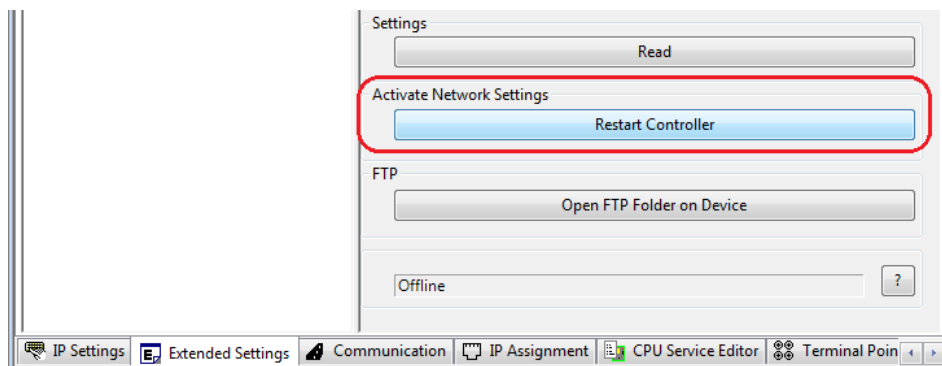

Figure 6-25 Activate Network Settings: Restart Controller

- If a prompt appears asking whether you really want to restart the controller, confirm the dialog with "Yes".
- In the "Settings Communication Path" dialog box, confirm the suggested IP address or the one you have set according to your application with "OK".

Alternatively, you can also select the connection via the USB interface as the communication path if a USB connection exists between the controller and your PC.

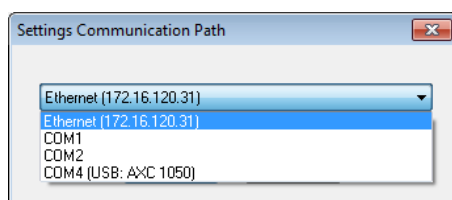

Figure 6-26 "Settings Communication Path" dialog

Successful execution of the service is displayed in the status window.

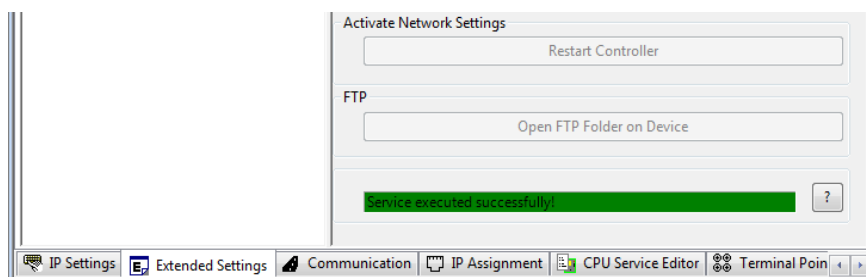

Figure 6-27 Activating the network settings: service executed successfully

The BF LED flashes following successful execution of the service. The AXC 1050 (XC) can now be read in as a PROFINET device in a PC Worx project.

6.5.2 Integrating the AXC 1050 (XC) as a PROFINET controller



The PROFINET controller function is not supported by the PC Worx Express software. The PC Worx software is required to use the PROFINET controller function.

If you have activated the PROFINET controller function ("PROFINET controller activated") or the PROFINET controller **and** device function ("PROFINET device activated / PROFINET controller activated") (see Section 6.5.1), you must now integrate the AXC 1050 (XC) as a PROFINET controller in the corresponding PC Worx project.

Follow these steps to integrate the AXC 1050 (XC) as a PROFINET controller:

- Adapt the IP address settings if necessary (see Section 6.3).
- Configure your bus structure:
 - Read in the Axioline F devices aligned on the AXC 1050 (XC) (see Section 6.4).
 - Read in the PROFINET devices connected to the AXC 1050 (XC) (see Section 6.5.3).

6.5.3 Integrating the AXC 1050 (XC) as a PROFINET device



The PROFINET device function is not supported by the PC Worx Express software. The PC Worx software is required to use the PROFINET device function.

If you have activated the PROFINET device function ("PROFINET device activated") or the PROFINET controller **and** device function ("PROFINET device activated / PROFINET controller activated") (see Section 6.5.1), you must now integrate the AXC 1050 (XC) as a PROFINET device in the corresponding PC Worx project.

Instructions for how to read in the controller as a PROFINET device using the "Read PROFINET" context menu are included below.



Alternatively, you can also select the PROFINET device manually from the "Device Catalog". For additional information on creating a PC Worx project, please refer to the online help or the quick start guide for the software.

The following conditions apply to the example project:

- Higher-level controller: RFC 470 PN 3TX
- Settings for the higher-level controller:
 - IP address LAN1.1/1.2: 192.168.0.2
 - Subnet mask: 255.255.255.0
 - PROFINET device name: rfc-4701
- Settings of the AXC 1050 as a PROFINET device:
 - IP address: 192.168.0.10
 - Subnet mask: 255.255.255.0
 - PROFINET device name: AXC-10501

You can read in the AXC 1050 (XC) as a PROFINET device if the following requirements have been fulfilled:

- The PROFINET device function of the AXC 1050 (XC) is activated (see Section 6.5.1).
- The PROFINET controller and PROFINET devices (AXC 1050 (XC) and other PROFINET devices corresponding to your application) are installed.
- A project is created in PC Worx.
- The PROFINET controller is configured according to your application.

AXC 1050 (XC)

- In the "Bus Structure" window, select "PROFINET" below the controller.
- Right-click to open the context menu and select "Read PROFINET..."

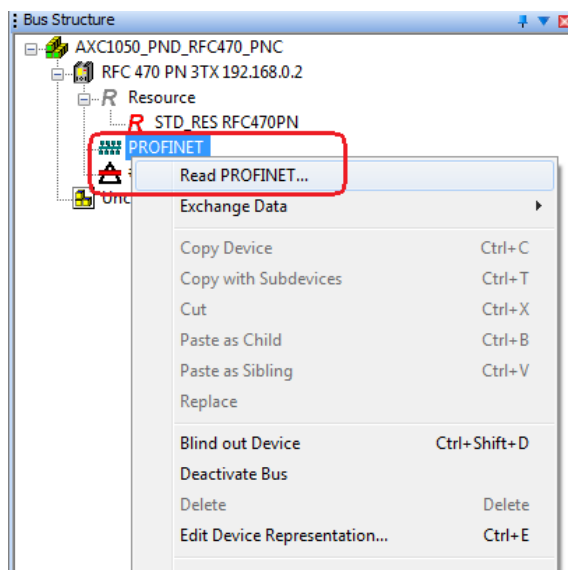

Figure 6-28 Bus Structure: PROFINET context menu "Read PROFINET..."

The "Read PROFINET" dialog that opens shows the PROFINET devices that are available in the connected network.

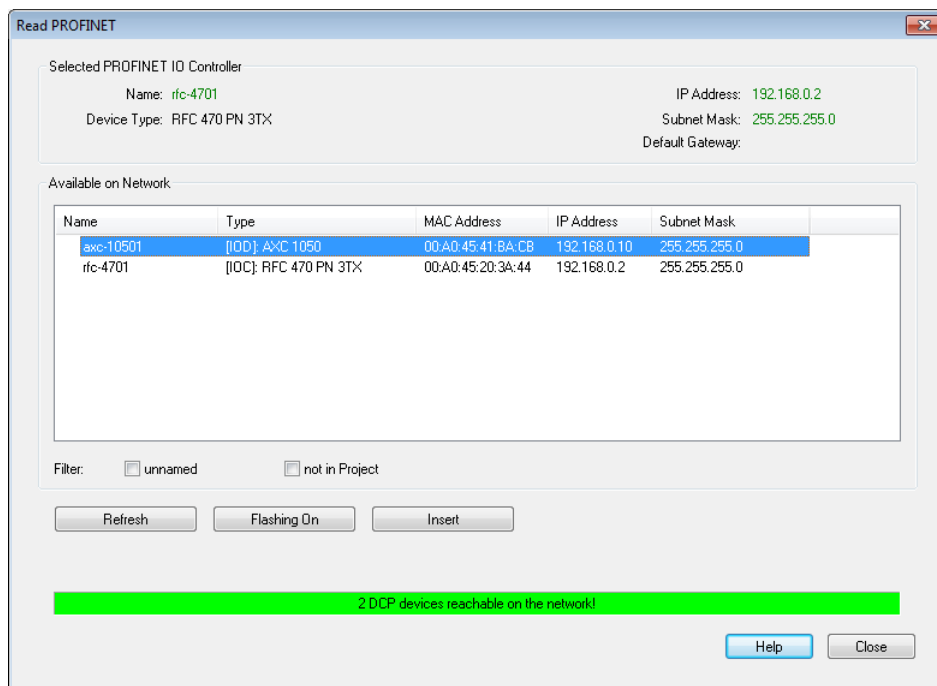

Figure 6-29 "Read PROFINET" dialog

- Select the AXC 1050 (XC).

- Click on the "Insert" button to insert the controller as a PROFINET device.
- Select the device description that corresponds to your device in the "Select PROFINET device description" dialog. Make sure the version is correct.

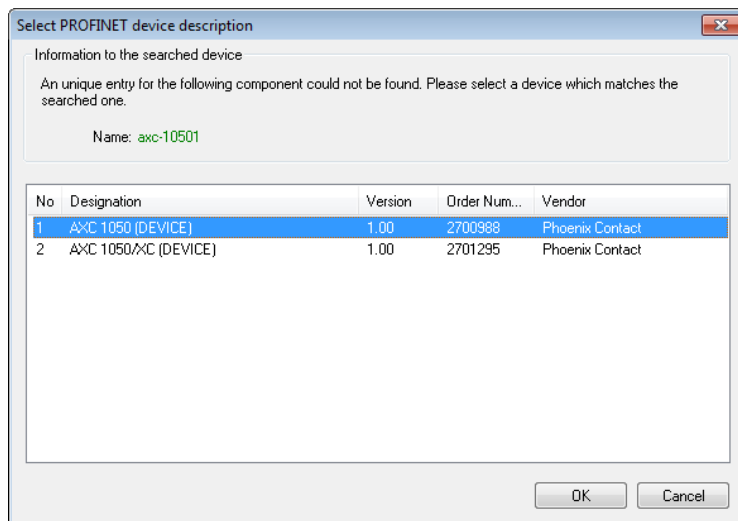

Figure 6-30 "Select PROFINET device description" dialog

- Confirm your selection with "OK".

If a PROFINET device name has not yet been assigned for the PROFINET devices to be inserted, you are prompted to assign one by PC Worx at this point.

- Assign a PROFINET device name to the device. To do so, proceed as described in the quick start guide or online help for PC Worx.

If PROFINET device names have already been assigned, follow the steps below:

- Repeat this procedure until you have inserted all of the PROFINET devices in your network in the project.
- Then click on the "Close" button to close the "Read PROFINET" dialog.

The inserted PROFINET device(s) is/are displayed in the "Bus Structure" window.

AXC 1050 (XC)

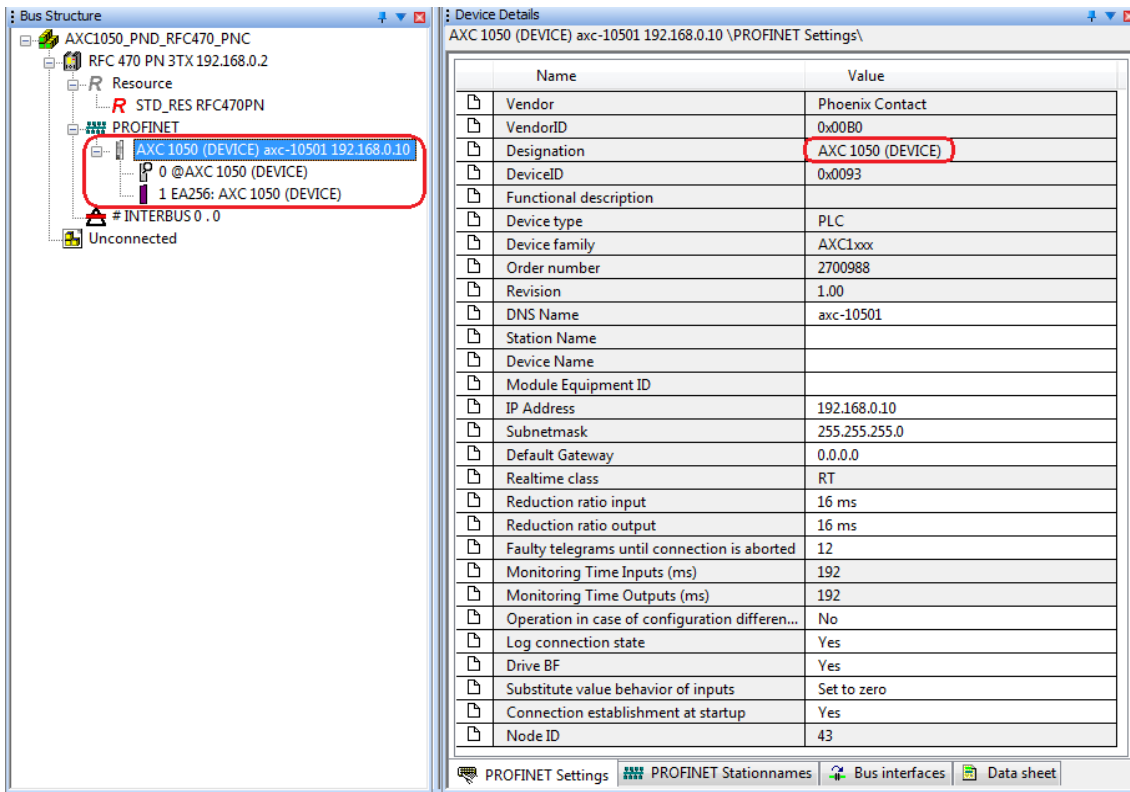

Figure 6-31 AXC 1050 (XC) inserted as a PROFINET device

The process data of the PROFINET device is displayed in "Device Details" in the "Process Data" tab.

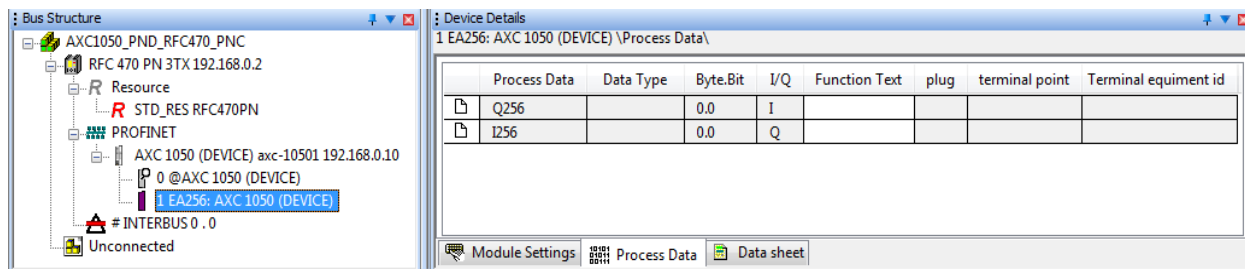

Figure 6-32 AXC 1050 (XC) as a PROFINET device: Process Data

The AXC 1050 (XC) is now available as a PROFINET device in the PC Worx project.

6.6 Setting the real-time clock

- Open the Bus Configuration Workspace.
- Select the controller in the "Bus Structure" window.
- In the "Device Details" window, switch to the "Extended Settings" tab.

For the real-time clock, you can either apply the system time from your PC or manually configure the desired time and data specifications.

Applying the system time

- Click the "System Time" button in the "Real-time Clock Settings" area.
- Click on the "Send" button to send the system time to the controller.

Manually setting the real-time clock

- Use the buttons in the "Time" area to set the desired time.
- Use the buttons in the "Date" area to set the desired date.
- Click on the "Send" button to send the settings to the controller.

6.7 Compiling after completing the bus topology

- When compiling a project for the first time, select the "Rebuild Project" entry from the "Build" menu.

You can use the "Make" entry from the "Build" menu for additional compiling procedures.

6.8 Using the SD card as the main memory or additional memory



The function is available for controllers with a firmware version ≥ 3.00 from AUTOMATIONWORX Software Suite 2017 Version 1.84 and later.

The SD card can be used as main or as additional memory.

Figure 6-33 shows how to proceed to use the SD card as the main or additional memory.

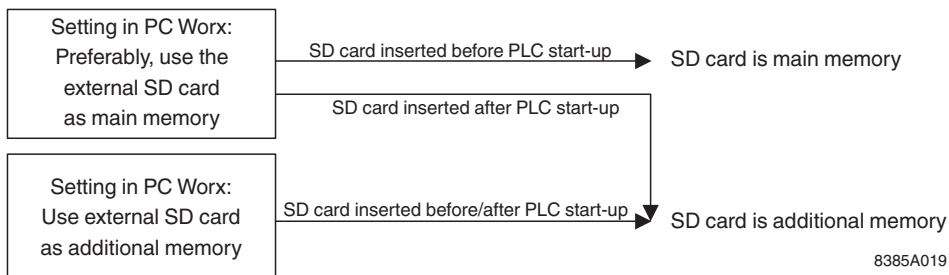

Figure 6-33 Procedure for using the SD card as the main or additional memory

Information on using the SD card as the main or additional memory can be found in the following sections.

6.8.1 Main memory



The function is available for controllers with a firmware version ≥ 3.00 from AUTOMATIONWORX Software Suite 2017 Version 1.84 and later.

If you use the SD card as the main memory, all application-specific data is stored on the SD card.

The SD card is recognized during initialization of the controller.

- Make sure that the SD card is inserted before switching on the controller to enable the controller to use it as the main memory.

The controller can be operated with or without an SD card as required. When changing operating modes (operating the controller with/without SD card), please note the following:

The SD card must not be removed while the controller is running.

Do not remove the SD card during operation



NOTE: Potential data loss

If you remove the SD card during operation, this may result in a loss of data.

- Do not remove the SD card during operation.

Should the SD card be accidentally removed during operation, the controller signals an error, stops processing the application program, and switches to the READY state. The FAIL LED indicates an error. If an online connection to PC Worx is established, the message window indicates that the SD card was unintentionally inserted or removed.

Changing operating modes

When changing operating modes (operating the controller with/without SD card), please note the following:

Change: operation without SD card → operation with SD card

To change the controller mode from "operation without SD card" to "operation with SD card", proceed as follows:

- Switch off the supply voltage of the controller.
- Insert the SD card, see Section 4.5.
- Switch on the supply voltage of the controller.



NOTE: Deletion of all data in the internal parameterization memory

When the controller is switched on, all application-specific data is deleted from the internal parameterization memory. PC Worx projects and IP configurations stored on the parameterization memory are no longer available. The controller accesses the data stored on the SD card.

Change: operation with SD card → operation without SD card

To change the controller mode from "operation with SD card" to "operation without SD card", proceed as follows:

- Switch off the supply voltage of the controller.
- Remove the SD card, see Section 10.4.
- Switch on the supply voltage of the controller.



NOTE: No data on the internal parameterization memory

Once the controller has been operated with the SD card, there is no data available on the internal parameterization memory. The controller therefore does not have an IP address.

- Assign an IP address to the controller as described in Section 6.3.

Settings in PC Worx

Figure 6-34 shows the setting in PC Worx for using the SD card as the main memory.

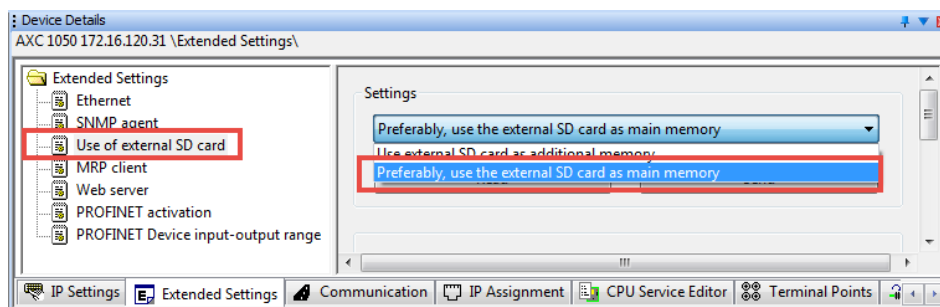

Figure 6-34 Setting the SD card as the main memory

- In the "Device Details" window, select the "Use of external SD card" setting under "Extended Settings".
- Under "Settings", select the "Preferably, use the external SD card as main memory" setting in the drop-down list.
- Click on the "Send" button (hidden by the drop-down list in Figure 6-34) to send the setting to the controller.
- Restart the controller.

AXC 1050 (XC)

Default setting

The "Preferably, use the external SD card as main memory" setting is activated by default in PC Worx.

If you do not change this setting, the following is valid:

- If the SD card is already inserted before starting up the controller (see also Figure 6-33 on page 72), the SD card is used as the main memory. All application-specific data is stored on the SD card.
- If the SD card is inserted after starting up the controller (see also Figure 6-33 on page 72), the SD card is used as the additional memory (see Section 6.8.2). All application-specific data is stored on the internal parameterization memory of the controller.

6.8.2 Additional memory



The function is available for controllers with a firmware version ≥ 3.00 from AUTOMATIONWORX Software Suite 2017 Version 1.84 and later.



WARNING: Explosion hazard AXC 1050 XC

In potentially explosive areas, the SD card must not be used as additional memory. Use the SD card as main memory only. Do not insert or remove the SD card during operation.

If the SD card is used as the additional memory, all application-specific data is stored on the internal parameterization memory of the controller.

If you are using an SD card with a license key, the license is still used.



NOTE: Function blocks are no longer executed under certain circumstances

If an SD card with license keys for function block libraries (SD FLASH XXX APPLIC A) is removed from the controller for more than 60 minutes, function blocks that require a license can no longer be executed under certain circumstances.

If the SD card is removed and reinserted into the controller within 60 minutes, all function blocks continue to be executed.

- Never remove an SD card with license keys for function block libraries from the controller for more than 60 minutes.

Use as additional memory

The SD card is used as additional memory (see also Figure 6-33 on page 72) if:

- The SD card is inserted **after starting up** the controller
- or
- You have selected the "Use external SD card as additional memory" setting in PC Worx.

Inserting/removing the SD card

The SD card may be inserted or removed before starting up and while operating the controller.



NOTE: Potential data loss

If you remove the SD card while read and/or write access to the SD card is active, this may result in a loss of data.

- Only remove the SD card when it is not being accessed.

Settings in PC Worx

Figure 6-35 shows the setting in PC Worx for using the SD card as the additional memory.

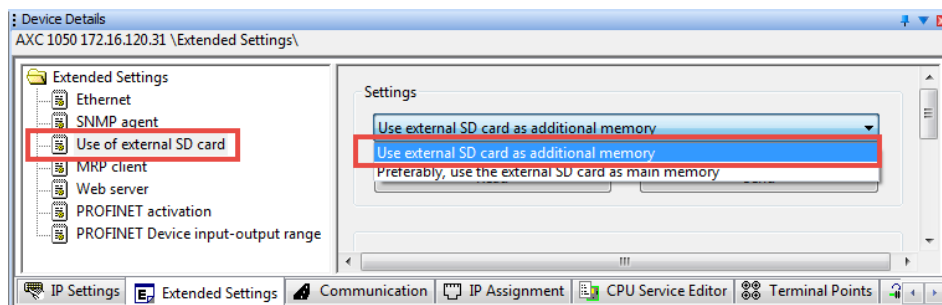

Figure 6-35 Setting the SD card as the additional memory

- In the "Device Details" window, select the "Use of external SD card" setting under "Extended Settings".
- Under "Settings", select the "Use external SD card as additional memory" setting in the drop-down list.
- Click on the "Send" button (hidden by the drop-down list in Figure 6-35) to send the setting to the controller.
- Restart the controller.

AXC 1050 (XC)**6.8.2.1 Using the SD card as the memory for log files**

You can use the SD card as the memory for log files.

The content of the "cfsroot" directory is shown in the "sddisk" directory on the SD card. You can view the directories on the SD card if you access the Inline controller via FTP (see Section 7.3).

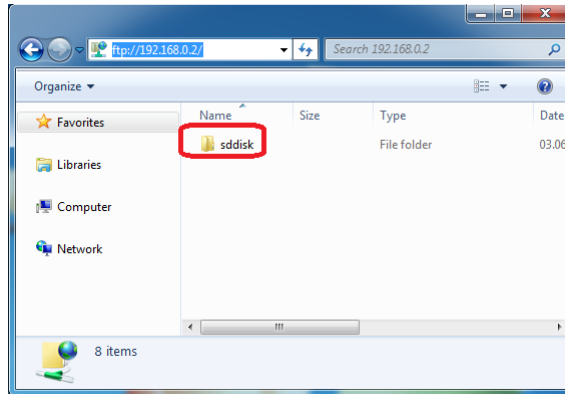

Figure 6-36 "sddisk" directory on the SD card

We recommend that you create a new directory within the "sddisk" directory to store log files:

- Access the controller via FTP.
- Double-click to open the "sddisk" directory.
- In the "sddisk" directory, right-click to open the context menu and select "New, Folder".
- Enter a name for the new directory (in the example in Figure 6-37 "Logfile").

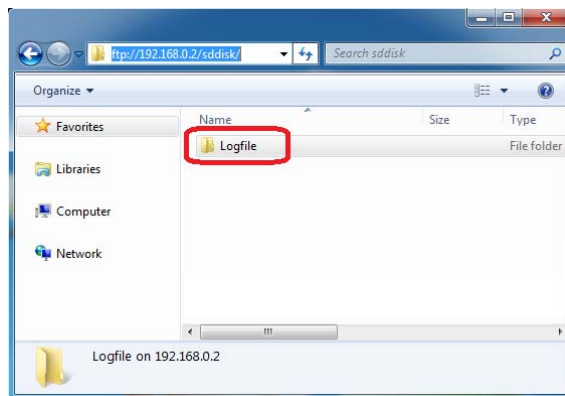

Figure 6-37 Newly created "Logfile" directory in the "sddisk" directory

To access the directories on the SD card, use the FILE function blocks in PC Worx (see Section 7.10 and online help for PC Worx).

When you program your application program accordingly, the log data in the "Logfile.txt" file will be saved and stored in the "Logfile" directory. You can then access the file using the FILE_OPEN function block.

Figure 6-38 shows a FILE_OPEN function block for opening the "Logfile.txt" file in the "\ssdisk\Logfile" directory.

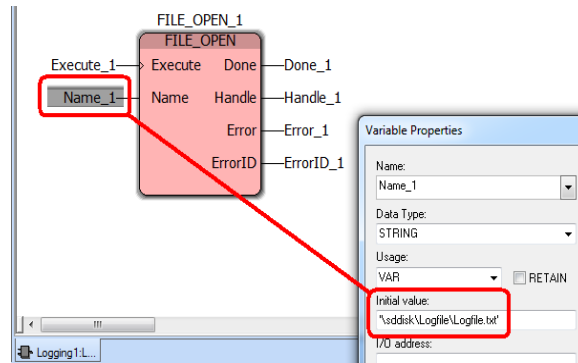

Figure 6-38 Opening the "Logfile.txt" file using the FILE_OPEN function block

- In the "Variable Properties" dialog (shown on the right in Figure 6-38) always enter the complete path and the file name.

6.9 Creating the program and variables

- Create the program.
- Create all necessary variables



For additional information on creating a program and creating variables, refer to the PC Worx (Express) software online help or quick start guide.

6.10 Compiling after creating the program

- Select the "Make" entry from the "Build" menu.

6.11 Assigning process data

- Assign the previously created variables to the process data.



For additional information on process data assignment, refer to the PC Worx (Express) software online help or quick start guide.

6.12 Compiling and sending a project and performing a cold restart

Compiling a project

- Select the "Make" entry from the "Build" menu.

Sending a project

- Send the project to the controller.



For additional information on sending a project to the controller, refer to the PC Worx (Express) software online help or quick start guide.

Performing a cold restart

- Perform a cold restart for the controller to start the project on the controller.



For additional information on performing a cold restart, refer to the PC Worx (Express) software online help or quick start guide.

7 Useful information about the PC Worx software

7.1 Diagnosing the Axioline F system

You can use the Diag+ 2 software to diagnose the Axioline F system.

- Open the Workspace Diagnostic in PC Worx to open Diag+ 2 within PC Worx.

Or

- Open the Diag+ 2 software as standalone software via "Start, All Programs, Phoenix Contact, AUTOMATIONWORX Software Suite <Version>, Diag+ 2.xx".



Please note:

The functional scope of Diag+ 2 as standalone software depends on your respective user rights. In the user management area for Diag+ 2, you can enable or disable individual functions for specific users. You can open the user management area via "Start, All Programs, Phoenix Contact, AUTOMATIONWORX Software Suite <Version>, Tools, DIAG+ Administration".

Diag+ 2 opens.

- Click the "Start Scan" button.

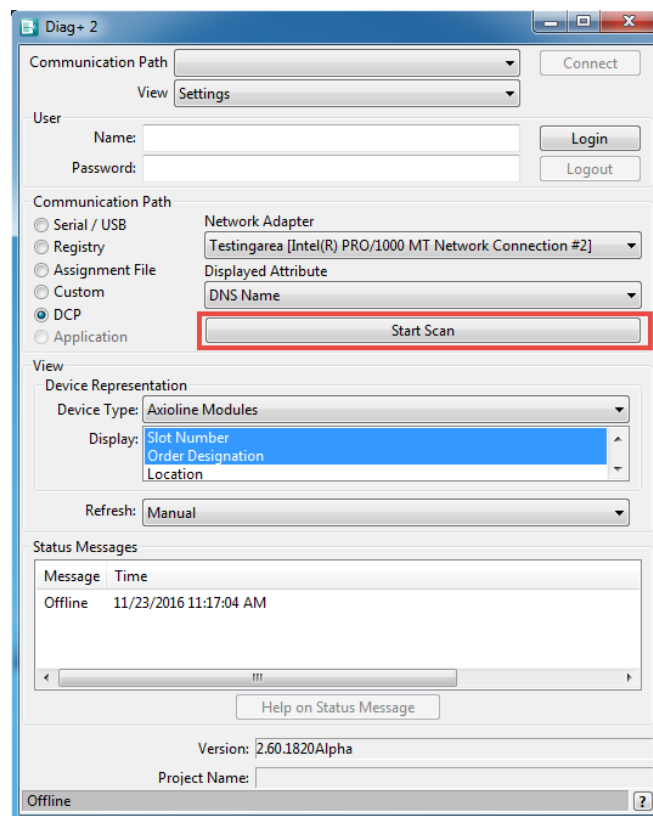

Figure 7-1 Communication path in Diag+ 2: Start Scan

AXC 1050 (XC)

After completing the scan process successfully, the AXC 1050 (XC) controller will display the following:

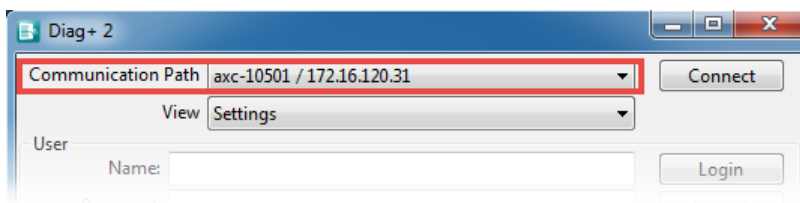

Figure 7-2 Communication path in Diag+ 2: AXC 1050 (XC) controller found

- Make sure that "Axiline Modules" is set as the device type in the "Device Representation" field (see Figure 7-1).

In this example, the "Slot Number" and "Order Designation" are selected for the display of the Axiline F modules.

- Click on the "Connect" button.

After the connection between Diag+ 2 and the controller has been established successfully, you are prompted at the bottom of the dialog box to select the diagnostic view.

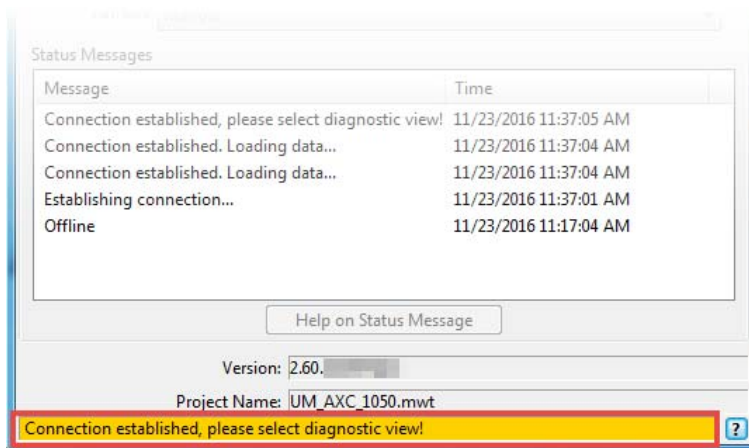

Figure 7-3 Connection established successfully: selecting the diagnostic view

Useful information about the PC Worx software

- At the top of the "Diag+ 2" dialog box, select "Axioline Diagnostic" as the view.

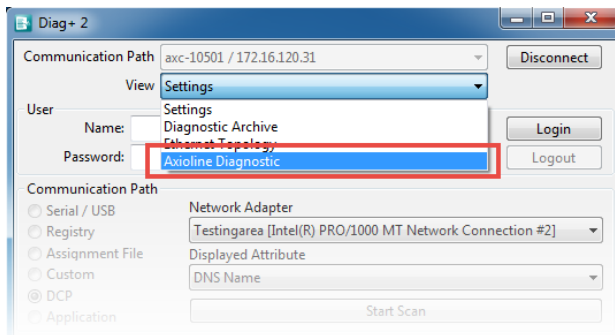

Figure 7-4 Diagnostic view: selecting "Axioline Diagnostic"

Diag+ 2 switches to the diagnostic view of the connected Axioline F system configured in PC Worx.

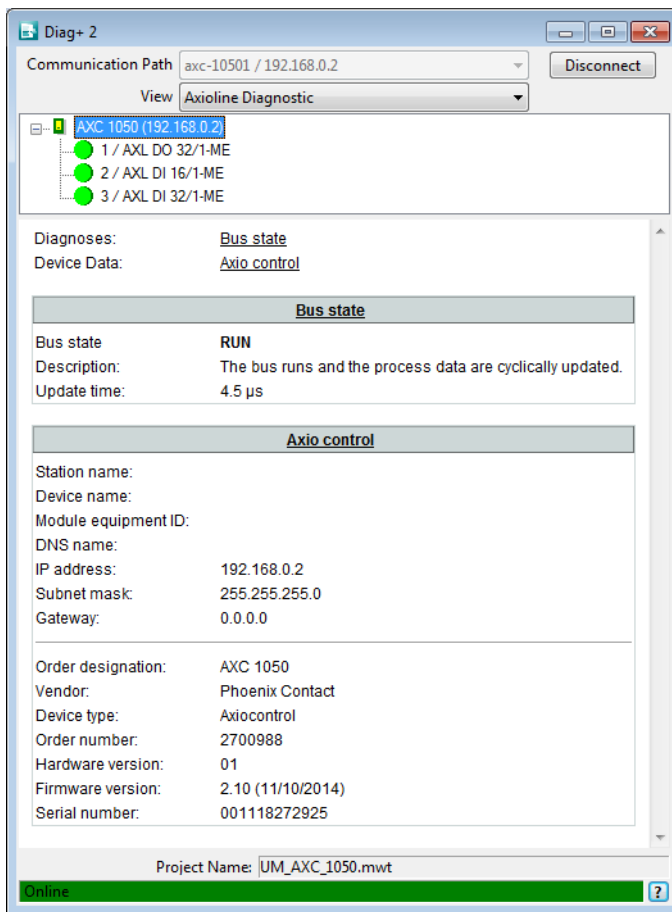

Figure 7-5 Diag+ 2: "Axioline Diagnostic"

AXC 1050 (XC)

Figure 7-6 shows the diagnostic view of an Axioline F module that is operating without errors.



Figure 7-6 AXL DI 32/1-ME Axioline F module: No error

Any errors that occur are diagnosed by Diag+ 2 and displayed.

Useful information about the PC Worx software

Figure 7-7 shows the diagnostic view of an Axioline F module with supply voltage that is not present.



Figure 7-7 AXL DI 32/1-ME Axioline F module: Supply voltage failure

AXC 1050 (XC)

Figure 7-8 shows the failure of the supply voltage for the Axioline F AXL DI 32/1-ME module at the selected controller.

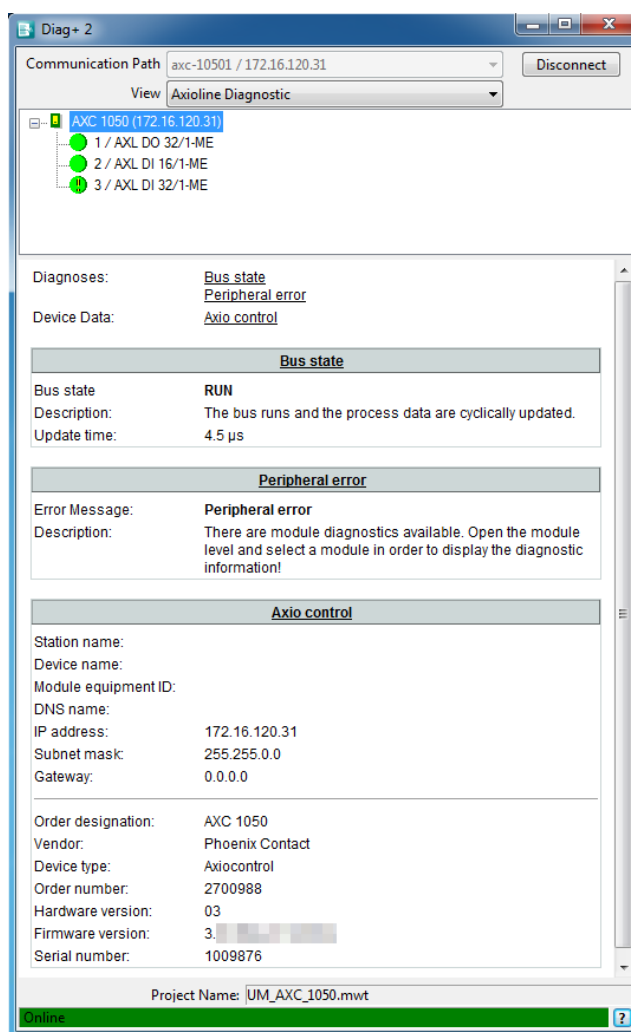

Figure 7-8 AXC 1050 controller – Peripheral fault

Diagnostics can be used to identify the error in your application.

Useful information about the PC Worx software

Controller context menu in Diag+ 2



The context menu of the controller can be used to influence the state of the Axioline F local bus.

If you have opened Diag+ 2 as standalone software using the "Start, All Programs, Phoenix Contact, AUTOMATIONWORX Software Suite <Version>, Diag+ 2.xx" menu, in some cases not all entries in the context menu will be shown to you. In these cases, you do not have the required user rights.

- In PC Worx, switch to the Workspace Diagnostic to open Diag+ 2 within PC Worx and to display the entire context menu.

Or

- Have the required user rights assigned to you and open Diag+ 2 again.

Or

- Open Diag+ 2 with administrator rights.

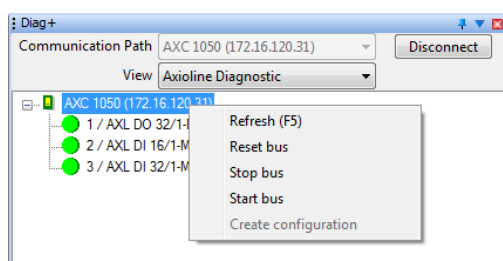

Figure 7-9 Controller context menu

The following menu items can be selected:

Refresh (F5)

Refreshes the view in the Diag+ 2 dialog.

Reset bus

Resets the local bus. After being reset, the local bus is in the READY state. The D LED lights up yellow.



The process data is no longer updated.

Stop bus

Stops cyclic updating of the process data. The local bus is then in the ACTIVE state.



The process data is no longer updated.

Start bus

If a valid configuration frame has been generated, the local bus can be started using this menu item. The process data is updated cyclically after the local bus is started.



The process data is updated again.

Create configuration

Generates a valid bus configuration using the Axioline F modules connected to the controller.

7.2 Applying the IP address immediately



The function is available for the AXC 1050 (XC) with a firmware version ≥ 3.00 from AUTOMATIONWORX Software Suite 2017 Version 1.84 and later.

When assigning the IP address via BootP (see Section 6.3.2) and manually assigning the IP address via USB (see Section 6.3.3), the IP address settings only take effect after a controller restart.

If you activate the function that immediately applies the IP address, then it is **not** necessary to perform a restart of the controller. The IP address settings take effect immediately.

This function for immediately applying the IP address is deactivated by default. The function can be activated or deactivated via the CPU_Set_Value_Request service with Var ID 01A2_{hex}.

Value range for the CPU_Set_Value_Request service:

Code	02CB _{hex}	
Var Count	1	
Var ID	01A2 _{hex}	
Value	0001 _{hex}	Activate function: IP address takes effect without restarting the controller
	0000 _{hex}	Deactivate function: IP address takes effect after restarting the controller

7.3 Parameterization memory and Internet Explorer®

To delete files or store application-specific files on the internal parameterization memory or SD card, proceed as follows:



The FTP functionality must be activated in Internet Explorer® (see Section 7.3.1).



- Open the Bus Configuration Workspace.
- Select the controller in the "Bus Structure" window (here: "AXC 1050").
- Select the "Extended Settings" tab in the "Device Details" window.
- Click the "Open FTP Folder on Device" button to open Internet Explorer®.

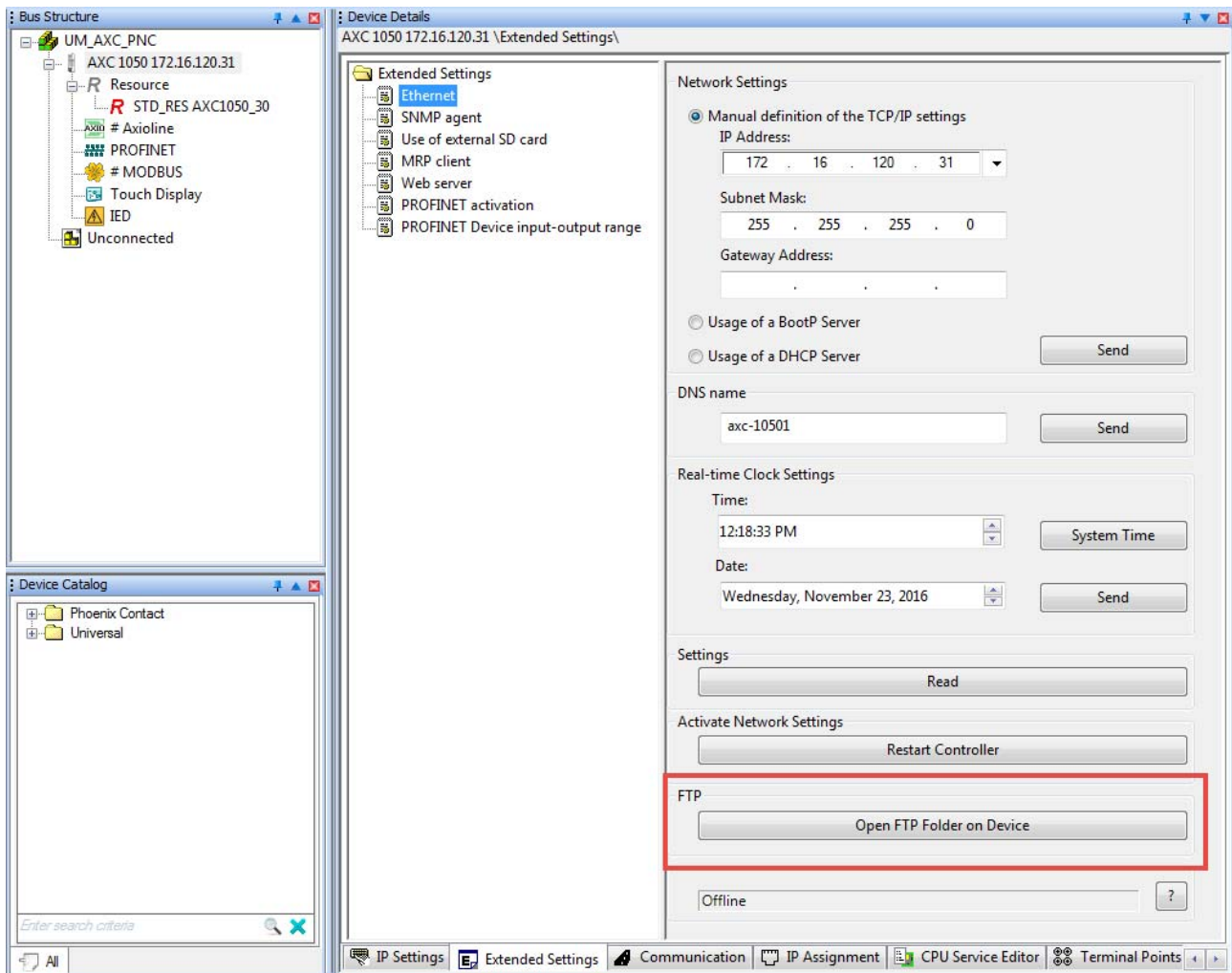

Figure 7-10 Extended Settings: Open FTP Folder on Device

AXC 1050 (XC)

The file structure, which is stored on the parameterization memory, is displayed in the Internet Explorer® window that opens.



Data may only be copied or deleted on the parameterization memory. Do not edit any files as Internet Explorer® does not store modified data.

- For the current state to be displayed, update the Internet Explorer® display after every action.

7.3.1 Activating the FTP functionality of Internet Explorer®

- Activate the FTP functionality of Internet Explorer under "Tools, Internet Options, Advanced".

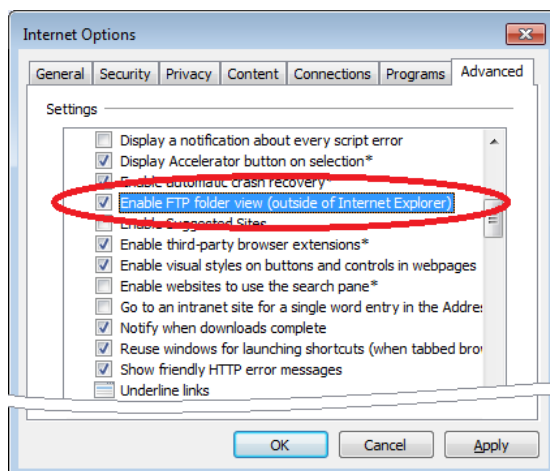

Figure 7-11 Internet Options: Enable FTP folder view

7.3.2 Activating/deactivating the FTP server

To protect the controller against unauthorized access, it may be necessary to deactivate the FTP server. The CPU_Set_Value_Request service with Var ID 0172_{hex} is used for this. The FTP server can be activated or deactivated with this service. The FTP server is deactivated as soon as the applicable service has been executed.

Activation of the FTP server does not take effect until the controller is restarted. The set FTP server state is stored in flash memory and mapped to the ETH_SRV_FTP_ACTIVE system variable.

Value range for the CPU_Set_Value_Request service:

Code	02CB _{hex}	
Var Count	1	
Var ID	0172 _{hex}	
Value	0000 _{hex}	Deactivate FTP server
	0001 _{hex}	Activate FTP server

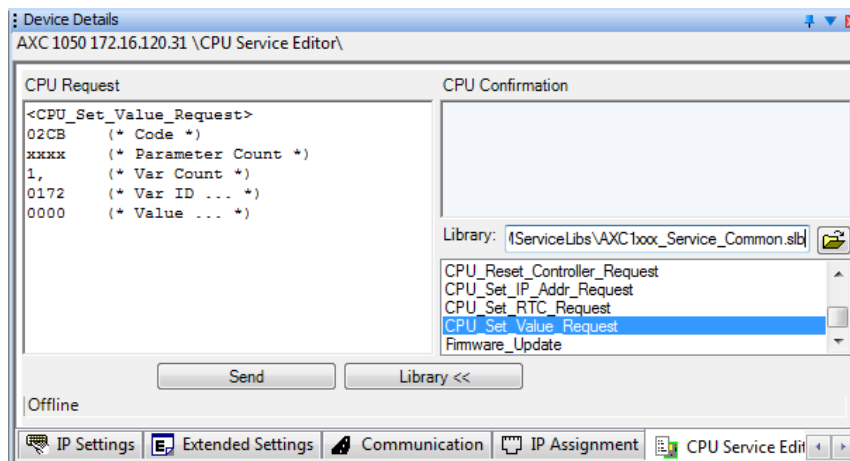

Figure 7-12 Deactivate FTP server

AXC 1050 (XC)**7.3.3 Creating, renaming or deleting via the FTP directory**

The function is available for the AXC 1050 (XC) with firmware versions ≥ 3.00 from AUTOMATIONWORX Software Suite 2017 Version 1.84 and later.

You can create directories on the internal parameterization memory or the SD card or delete directories that have already been created. To do this, proceed as follows:

- Access the controller via FTP.
- Open the directory where you want to create a new directory or delete a directory.

Creating a directory

- In the directory, right-click to open the context menu and select "New, Folder".
- Enter a name for the new directory.

Renaming the directory

- Right-click to open the context menu for the directory to be renamed.
- Select "Rename".
- Specify the new name of the directory.

Deleting the directory

- Right-click to open the context menu for the directory to be deleted.
- Select "Delete".



Please note the following:

The directory and all the files and directories it contains are deleted in the deletion process.

- Before the deletion process, ensure that you no longer need the directory and all the files and directories it contains.

7.3.4 Restricting FTP access



The function is available for the AXC 1050 (XC) with a firmware version ≥ 3.00 from AUTOMATIONWORX Software Suite 2017 Version 1.84 and later.

To prevent unauthorized FTP access to the parameterization memory (internal parameterization memory or SD card), you can define a user name (max. twelve characters) and a password (max. twelve characters) for access. By default upon delivery, the user name for the controller is set to "anonymous" and there is no password (""). This setting is also restored when you reset the controller to the delivery state.

The CPU_Set_Value_Request service with Var ID 019A_{hex} is used to define a user name and password.

Defining a user name and password

To define a user name and password, proceed as follows:

- Open the Bus Configuration Workspace.
- Select the controller in the "Bus Structure" window.
- In the "Device Details" window, select the "CPU Service Editor" tab.
- Open the "AXC1xx_Service_Common.slb" library.
- Double-click to select the "CPU_Set_Value_Request" service.

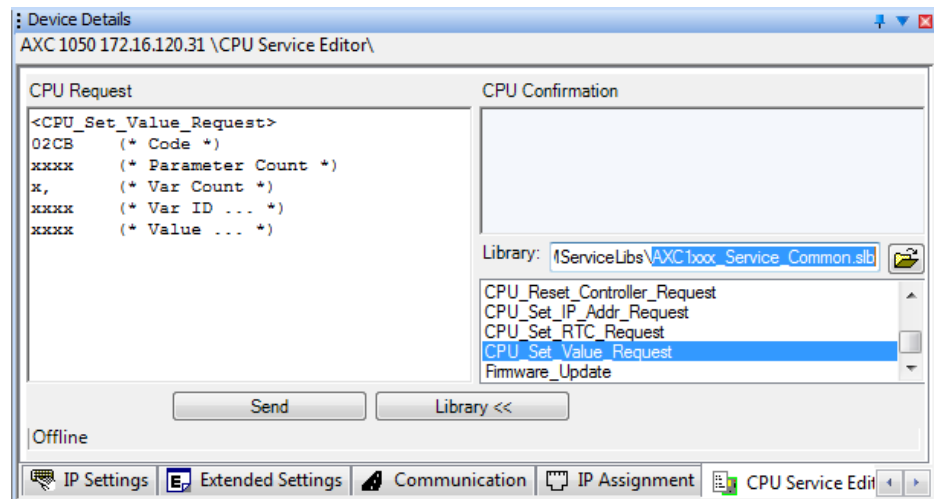

Figure 7-13 Opening the library and selecting the service

- Under "CPU Request" enter the value "1" for (* Var Count *).
- Under "CPU Request" enter the value "019A" for (* Var ID ... *).
- Under "CPU Request" enter the desired user name and password for (* Value ... *) (in Figure 7-14 changed to (* length username & username *) and (* length password & password *)).

Here the length of the user name must be entered first, followed by the individual characters of the user name in hexadecimal ASCII format. Then the length of the password must be entered, followed by the individual characters of the password in hexadecimal ASCII format.

AXC 1050 (XC)**Example:**

User name "USER" (length "04"), password "PASS" (length "04")

Character	ASCII	Character	ASCII
U	55	P	50
S	53	A	41
E	45	S	53
R	52	S	53

For the example shown, the ASCII characters "0455 5345 52" (length of the user name followed by the individual characters of the user name) must be entered for the user name "USER" followed by the ASCII characters "04 5041 5353" (length of the password followed by the individual characters of the password) for the password "PASS".

Figure 7-14 shows the settings for defining the user name "USER" and the password "PASS" under "CPU Request".

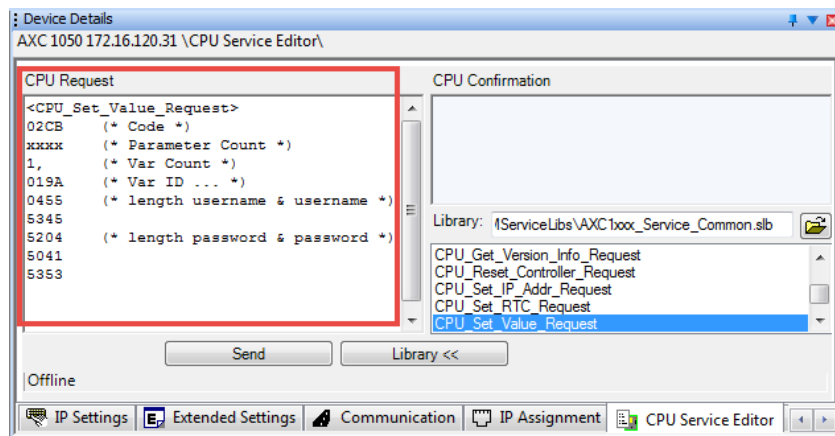

Figure 7-14 Defining a user name and password for FTP access

- Click on the "Send" button to send the settings to the controller.

The new user name and password are set.

The successful execution of the service is acknowledged under "CPU Confirmation" as follows:

```
<Cnf: CPU_Set_Value_Request>
82CB (*W1 : Confirmation_Code*)
0001 (*W2 : Parameter_Count*)
0000 (*W3 : Result*)
```

- Carry out a voltage reset on the controller.

Useful information about the PC Worx software

When accessing the parameterization memory via FTP, a dialog now appears in which the user name and password must be entered.

The content of the parameterization memory is only displayed if the user name and password entered are correct.



Recommended:

If you wish to access the parameterization memory via a web browser, deactivate the web browser's buffer (cache).

Otherwise the content of the parameterization memory may be displayed even if access protection has been activated, if, for example, data from the last time the memory was accessed without access protection is still stored in the web browser's cache.

Removing the user name and password

To remove the user name and password, proceed as described above but under "CPU Request" enter the value "0000" for (* Value ... *); see Figure 7-15.

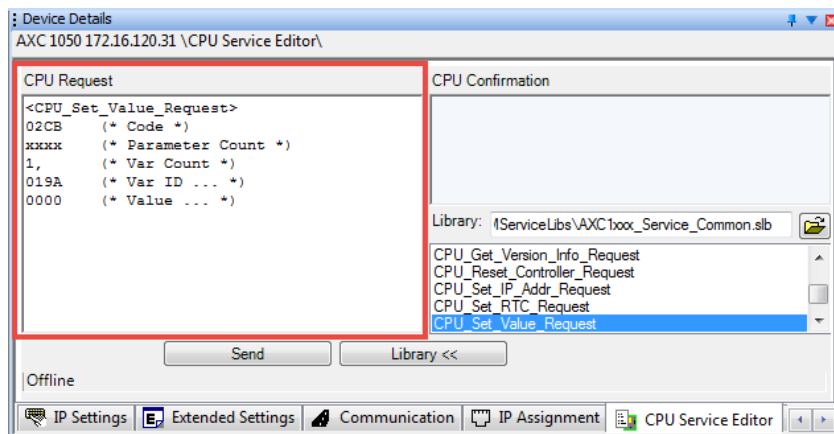

Figure 7-15 Removing the user name and password for FTP access

7.4 Web server

The AXC 1050 (XC) controller has a web server that can communicate via HTTP or HTTPS. With its visualization software, you can use the web server to visualize control variables, for example, in a web browser.



The Hypertext Transfer Protocol (HTTP) is set on the controller by default.

7.4.1 Activating/deactivating the HTTP server

To protect the controller against unauthorized access, it may be necessary to deactivate the HTTP server. To do this, proceed as follows:



- Open the Bus Configuration Workspace.
- Select the controller in the "Bus Structure" window.
- Select the "Extended Settings" tab in the "Device Details" window.
- Under "Extended Settings" select the "Web server" setting.
- Select the "Disabled" setting from the drop-down list.
- Click on the "Send" button (hidden by the drop-down list in Figure 7-16) to send the setting to the controller.
- Restart the controller.

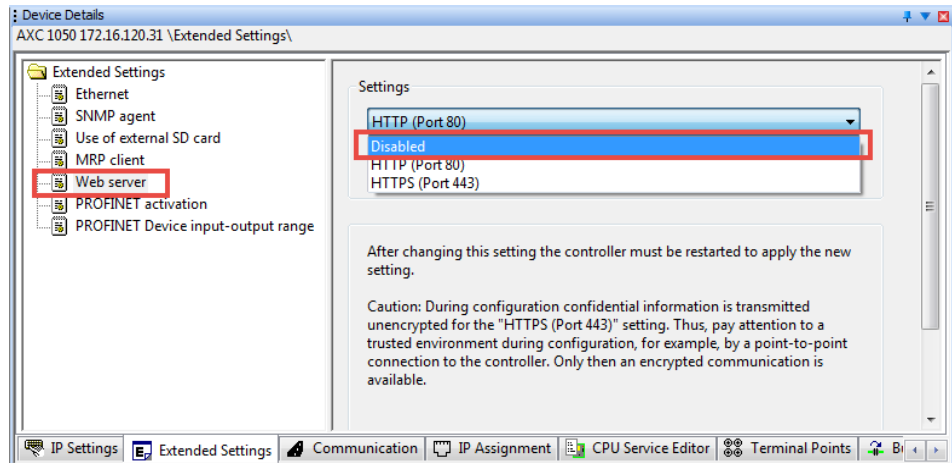

Figure 7-16 Disabling HTTP



Once you have selected the "Disabled" setting, the HTTP server (web server) will be disabled. HTTPS (see Section 7.4.2) will also be disabled.

Enabling

Proceed as follows to enable the HTTP server:

- In the drop-down list select the setting "HTTP (Port 80)".
- Click on the "Send" button (hidden by the drop-down list in Figure 7-16) to send the setting to the controller.
- Restart the controller.



You can use HTML5 from the WebVisit software to access the web server of the controller.

7.4.2 Using the Hypertext Transfer Protocol Secure (HTTPS)



The controller supports the Hypertext Transfer Protocol Secure (HTTPS) starting from firmware version 2.10 or later and from PC Worx (Express) version 6.30 or later (part of the AUTOMATIONWORX Software Suite 2015 1.82).



NOTE: Communication errors

There is interference in the HTTPS communication via Ethernet when using Phoenix Contact web panels with the AXC 1050 (XC).

- When using Phoenix Contact web panels with the AXC 1050 (XC), establish an HTTP connection to prevent communication interference.



Security certificates from the web server are always accepted by the controller without being verified.

Hypertext Transfer Protocol Secure (HTTPS) can be used for web server communication. To do this, proceed as follows:



- Open the Bus Configuration Workspace.
- Select the controller in the "Bus Structure" window.
- In the "Device Details" window, switch to the "Extended Settings" tab.
- Under "Extended Settings" select the "Web server" setting.
- Select "HTTPS (Port 443)" from the drop-down list.
- Click on the "Send" button (hidden by the drop-down list in Figure 7-17) to send the setting to the controller.
- Restart the controller.

AXC 1050 (XC)

Figure 7-17 Web server: using HTTPS

7.5 Sending e-mails securely

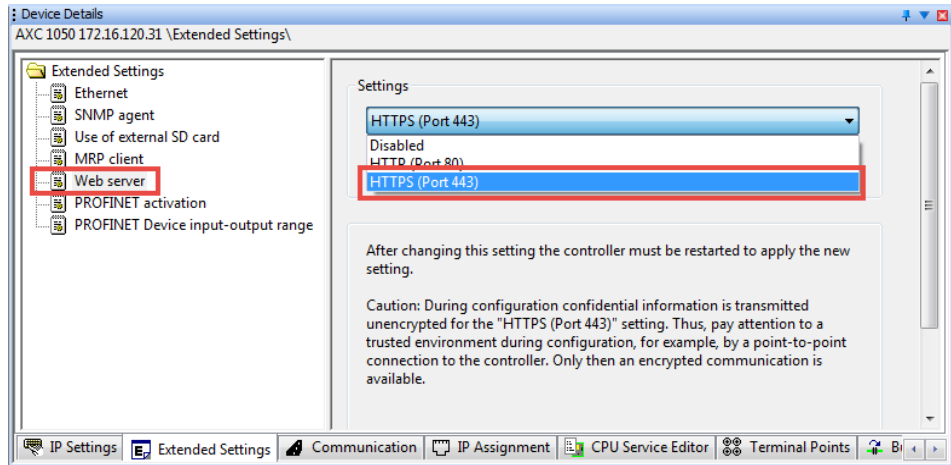

The function is available for the AXC 1050 (XC) with a firmware version ≥ 3.00 from AUTOMATIONWORX Software Suite 2017 Version 1.84 and later.

You can use the SMTPS method (e-mailing via SMTP with SSL/TLS) for secure e-mailing. In order to use the SMTPS method, you need to import the latest version of the "IT_Library" function block library. It can be downloaded via the product page at phoenixcontact.net/products.

For more detailed information about the function block library, please refer to the online help for PC Worx.



Security certificates from the mail server are always accepted by the controller without being verified.

7.6 Activating/deactivating specific ports



The function is available for the AXC 1050 (XC) with a firmware version ≥ 3.00 from AUTOMATIONWORX Software Suite 2017 Version 1.84 and later.

Depending on your application, it may be necessary to activate or deactivate specific ports. The CPU_Set_Value_Request service is used for this, with different Var IDs for the individual ports. A port can be activated or deactivated with this service. The port is deactivated as soon as the applicable service has been executed.

Activation of a port does not take effect until the controller is restarted

Port 21

Value range for the CPU_Set_Value_Request service for port 21 (port for FTP server access):

Code	02CB _{hex}	
Var Count	1	
Var ID	0172 _{hex}	
Value	0000 _{hex}	Deactivate port 21
	0001 _{hex}	Activate port 21

Port 1962



NOTE: Access to the controller not possible

If you deactivate port 1962, you will no longer be able to access the controller from PC Worx.

- Only deactivate port 1962 if you no longer need to access the controller from PC Worx.

Once you have deactivated port 1962, this can only be reactivated by resetting the controller to the default settings.

Value range for the CPU_Set_Value_Request service for port 1962 (port for communication with PC Worx):

Code	02CB _{hex}	
Var Count	1	
Var ID	0213 _{hex}	
Value	0000 _{hex}	Deactivate port 1962
	0001 _{hex}	Activate port 1962

7.7 Activating/deactivating the journaling function

The file system of the parameterization memory supports the journaling function. As a result, voltage failures during write processes do not destroy the file system; however, the access speed becomes slower.



The journaling function is deactivated by default.

It can be activated or deactivated via the CPU_Set_Value_Request service with Var ID 0194_{hex}.

Value range for the CPU_Set_Value_Request service:

Code	02CB _{hex}	
Var Count	1	
Var ID	0194 _{hex}	
Value	0000 _{hex}	Deactivate journaling function
	0001 _{hex}	Activate journaling function

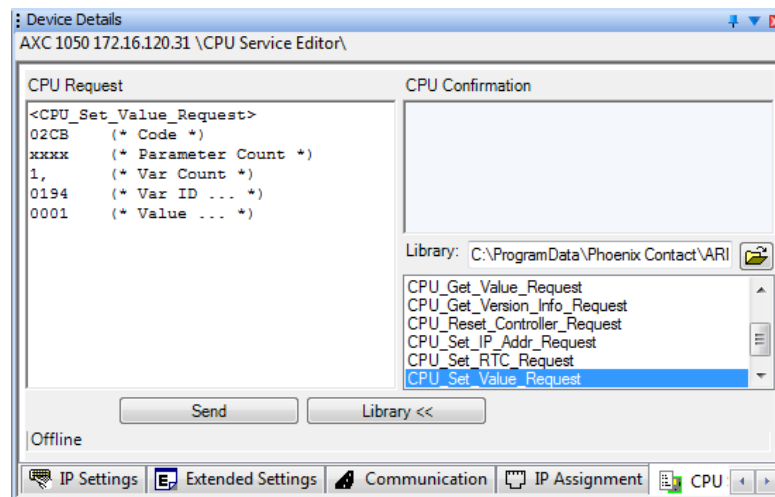

Figure 7-18 Activate journaling function

7.8 Activating/deactivating or reading the MRP client function

The Media Redundancy Protocol (MRP) can be used via the Ethernet interfaces of the AXC 1050 (XC) controller. The controller supports the MRP client function. This function is disabled by default. If the function is enabled, it remains enabled after the supply voltage is switched off and on. If the controller has been reset to the delivery state, the MRP client function will also be disabled again. In a ring with Media Redundancy Protocol, maximum switch-over times of up to 200 ms can be expected.

To activate or deactivate the MRP client function, proceed as follows:

- Open the Bus Configuration Workspace.
- Select the controller in the "Bus Structure" window.
- Select the "Extended Settings" tab in the "Device Details" window.
- In the "Device Details" window, select the "MRP client" setting under "Extended Settings".
- Under "Settings", select "activated" to activate the MRP client function or
- Under "Settings", select "deactivated" to deactivate the MRP client function.
- Click on the "Send" button (hidden by the drop-down list in Figure 7-19) to send the setting to the controller.
- Restart the controller.

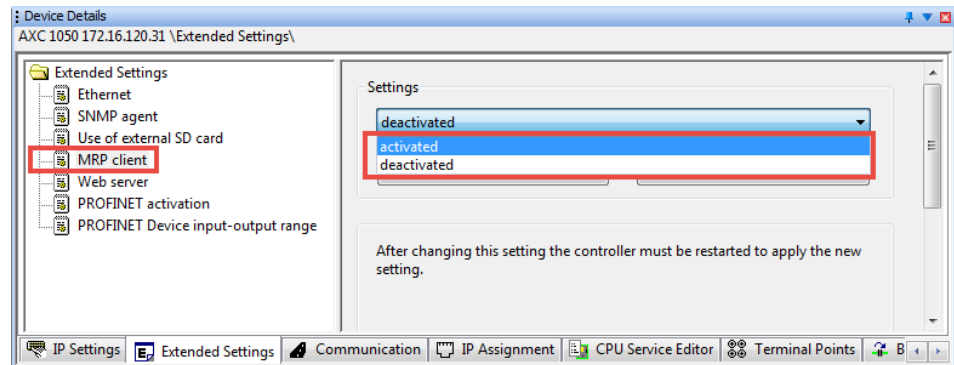

Figure 7-19 Activating or deactivating the MRP client function

Querying the setting

You can use the controller to query the current setting ("activated" or "deactivated") of the MRP client function.

- Click on the "Read" button (hidden by the drop-down list in Figure 7-19) to query the setting.

After the read process, the current setting is displayed in the "Settings" area.

7.9 Event task for the "Power failure" event

If the supply voltage fails in the application, it may make sense to start data backup automatically, e.g., to protect the application. In this case, an event task can be defined in PC Worx, which is started in the case of the "Power failure" event. To do this, proceed as follows:



- Open the IEC programming workspace.
- In the context menu for the "Tasks" directory, select the "Insert, Task.." menu item.

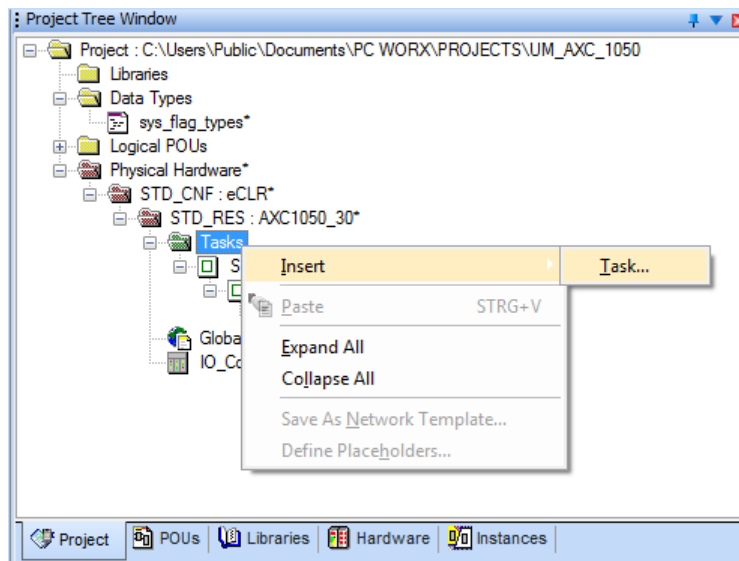

Figure 7-20 "Insert, Task..." context menu

The "Insert" dialog opens.

- Enter a name for the task in the "Name" input field ("PowerOf" in the example).
- Select the "EVENT" task type in the "Task type" drop-down list.

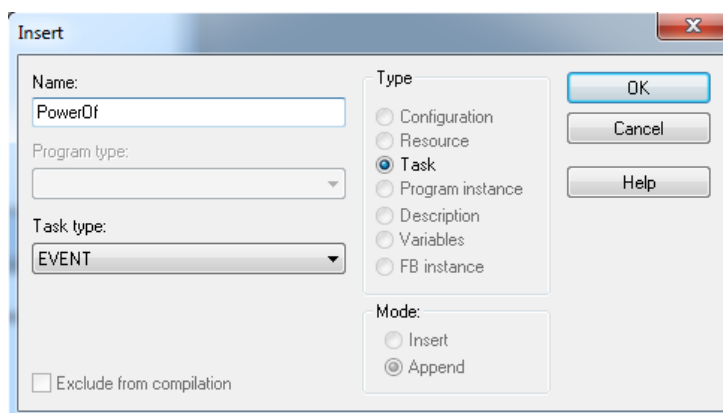

Figure 7-21 "Insert" dialog

- Confirm your entries with "OK".

Useful information about the PC Worx software

The "Task settings for 'PowerOf'" dialog opens.

- Select the "Power failure" event from the "Event" drop-down list.
- Enter the priority of the event task in the "Priority" input field.
- If you want to use a watchdog:
Enter the watchdog time in the "Watchdog Time" input field.
- If you do not want to use a watchdog:
Disable the "Enable Watchdog" check box.
- Click on "OK" to save your entries.

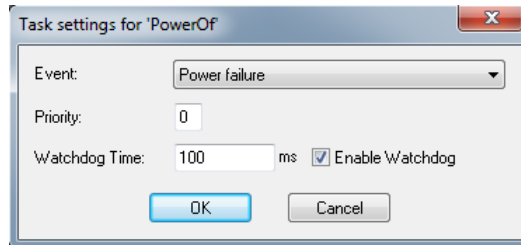

Figure 7-22 "Task settings for 'PowerOf'" dialog

The previously defined "PowerOf" event task is displayed in the "Project Tree Window".

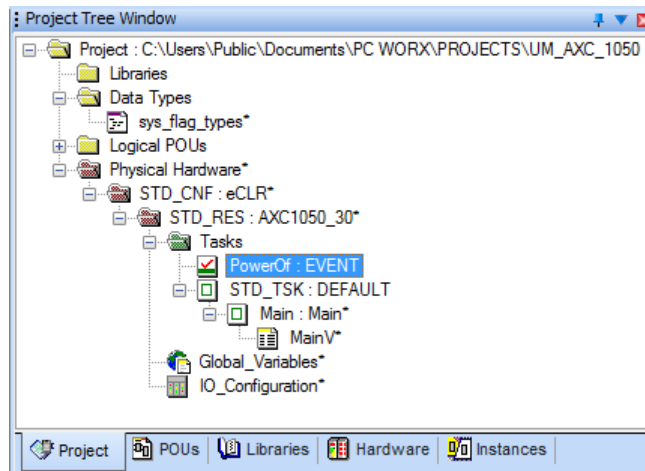

Figure 7-23 "PowerOf" event task

7.10 Function blocks for handling files on the parameterization memory

The function blocks enable access to files on the internal parameterization memory or the SD card of the controller. Some of the blocks support multiple instantiation. This means that it is possible to work with a number of different files within the same project. The blocks perform the standard functions that are required for typical file access operations.

The FILE_NOTIFY block is available in addition to the blocks for typical file access operations. This block can be used to detect files that have been modified in a directory containing user files. These modifications may include:

- Deletion of one or more files
- Writing one or more new files
- Modification of one or more existing files

Both modifications made to this directory via FTP (remote) and modifications made locally via function blocks or firmware services can be detected.



All file operations are subject to the following restrictions:
No directory hierarchies are supported. All file operations only affect the root directory of the parameterization memory.

The function blocks are valid for the controller in hardware version 01 or later and firmware version 1.00 or later.

Table 7-1 Function block overview

Function block	Short description
FILE_OPEN	Opens a file with a specific name.
FILE_CLOSE	Closes a file with a specific handle.
FILE_READ	Reads from a file with a specific handle.
FILE_WRITE	Writes to a file with a specific handle.
FILE_REMOVE	Deletes a file with a specific name.
FILE_TELL	Determines the current position of the file pointer in a file.
FILE_SEEK	Moves the current file pointer to a new position.
FILE_NOTIFY	Displays files that have recently been created, deleted or modified.



The function blocks for handling files on the parameterization memory are described in the PC Worx (Express) online help.

7.11 Function blocks for Ethernet communication

7.11.1 IP communication blocks

The IP communication blocks enable IEC 61131-5-compliant communication between controllers via Ethernet or communication between controllers and Ethernet devices via TCP/IP or UDP/IP.

The functional blocks are valid for the controllers listed in the table below in the specified hardware/firmware versions and support the specified maximum number of TCP/IP or UDP/IP communication connections:

Order designation	Blocks	As of hardware version (HW)	As of firmware version (FW)	Ethernet connections to other communication partners (maximum)
AXC 1050 (XC)	IEC-61131-5	01	1.00	8
	TCP/IP			16
	UDP/IP			

Table 7-2 Overview of the IP communication blocks

Function block	Short description
IP_CONNECT	Establishes a connection between two communication partners.
IP_USEND	Transmits data to a communication partner.
IP_URCV	Receives data from a communication partner.



The IP communication blocks are described in the PC Worx (Express) online help. The extensions for the TCP/IP and UDP/IP function blocks are described in the "AH EN FB TCP/UDP COMMUNICATION" application note.

AXC 1050 (XC)

7.11.2 ETH communication blocks in accordance with IEEE 802.3



The function is available for the AXC 1050 (XC) with a firmware version ≥ 3.00 from AUTOMATIONWORX Software Suite 2017 Version 1.84 and later.

ETH communication blocks can be used to establish communication via all Ethernet protocols.

In addition, the ETH communication blocks enable communication to take place on the data link layer of the ISO/OSI model (layer 2 communication) according to IEEE 802.3.

7.11.2.1 ETH_SEND function block

The function block sends Ethernet telegrams to one or more communication partners. A maximum of ten instances of the function block are permitted.

Function block

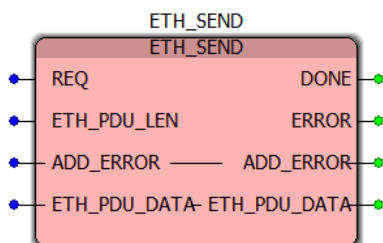

Figure 7-24 ETH_SEND function block

Input parameters

Table 7-3 Inputs of the ETH_SEND function block

Name	Data type	Description
REQ	BOOL	The Ethernet telegram at the ETH_PDU_DATA input/output function block is sent on a positive edge at this input.
ETH_PDU_LEN	INT	Total length of the Ethernet telegram to be sent

Useful information about the PC Worx software

Output parameters

Table 7-4 Outputs of the ETH_SEND function block

Name	Data type	Description
DONE	BOOL	TRUE: The function block was executed. The Ethernet telegram was sent. The TRUE status is valid for each PLC cycle. FALSE: The Ethernet telegram was not sent.
ERROR	BOOL	TRUE: An error has occurred The Ethernet telegram was sent. The TRUE status is valid for each PLC cycle. The ADD_ERROR input provides error details (see Table 7-5). FALSE: No error has occurred

Input/output parameters

Table 7-5 Inputs/outputs of the ETH_SEND function block

Name	Data type	Description
ADD_ERROR	ARRAY [0...1] OF WORD	The first word of the array contains the error class. The error class is always 0x09B0 (ERR_FB_ERROR). The second word contains the error code of the error that has occurred (ERROR output = TRUE), see Table 7-6.
ETH_PDU_DATA	ARRAY [0...1517] OF BYTE	Ethernet frame to be sent

ADD_ERROR input/output
(ERROR = TRUE)

Table 7-6 Error codes of the "ADD_ERROR" input/output (ERROR output = TRUE)

Value	Description
0x01	ERR_ADDE_FB_ETH_PDU_INVALID_TYPE Incorrect data type at the ETH_PDU_DATA input/output. ARRAY data type required
0x02	ERR_ADDE_FB_ETH_PDU_NO_BYTE_ARRAY_TYPE Incorrect data type at the ETH_PDU_DATA input/output. Permissible data type: ARRAY [0...1517] OF BYTE

AXC 1050 (XC)

Table 7-6 Error codes of the "ADD_ERROR" input/output (ERROR output = TRUE)

Value	Description
0x03	ERR_ADDE_FB_ETH_PDU_INVALID_SIZE Invalid Ethernet frame length at the ETH_PDU_DATA input/output. Permissible length: 18 ... 1518 Bytes
0x04	ERR_ADDE_FB_ETH_LEN_INVALID The Ethernet telegram length input at the ETH_PDU_LEN input is larger than the buffer storage unit of the ETH_PDU_DATA input/output.
0x06	ERR_ADDE_FB_ETH_SEND_ERROR An error occurred when sending the Ethernet frame.

7.11.2.2 ETH_RECV function block

The function block receives Ethernet frames from one or more communication partners. A maximum of ten instances of the function block are permitted.

Function block

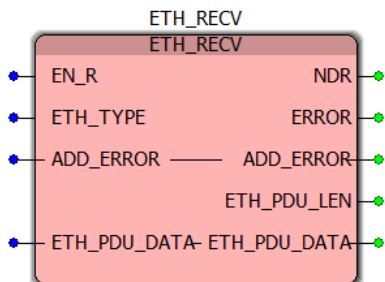

Figure 7-25 ETH_RECV function block

Input parameters

Table 7-7 Inputs of the ETH_RECV function block

Name	Data type	Description
EN_R	BOOL	The function block is activated on a positive edge at this input and waits for incoming Ethernet telegrams.
ETH_TYPE	UINT	Type field (EtherType) of the Ethernet telegram to be received Please note: <ul style="list-style-type: none"> - The type field 0x0600 must be used to receive Ethernet I-frames. - The type fields 0x0800 (IP) and 0x0806 (ARP) are not permitted for the function block. Ethernet frames with these type fields cannot be received.

Useful information about the PC Worx software

Output parameters

Table 7-8 Outputs of the ETH_RECV function block

Name	Data type	Description
NDR	BOOL	Indicates whether an Ethernet telegram was received TRUE: An Ethernet telegram was received. FALSE: No Ethernet telegram was received.
ERROR	BOOL	TRUE: An error has occurred. The Ethernet telegram was not received. The TRUE status is valid for each PLC cycle. The ADD_ERROR input provides error details (see Table 7-10). FALSE: No error has occurred.
ETH_PDU_LEN	INT	Total length of the received Ethernet telegram

Input/output parameters

Table 7-9 Inputs/outputs of the ETH_RECV function block

Name	Data type	Description
ADD_ERROR	ARRAY [0...1] OF WORD	Error code of the error that has occurred (ERROR output = TRUE)
ETH_PDU_DATA	ARRAY [0...1517] OF BYTE	Received Ethernet frame

ADD_ERROR input/output
(ERROR = TRUE)

Table 7-10 Error codes of the "ADD_ERROR" input/output (ERROR output = TRUE)

Value	Description
0x01	ERR_ADDE_FB_ETH_PDU_INVALID_TYPE Incorrect data type at the ETH_PDU_DATA input/output. ARRAY data type required
0x02	ERR_ADDE_FB_ETH_PDU_NO_BYTE_ARRAY_TYPE Incorrect data type at the ETH_PDU_DATA input/output. Permissible data type: ARRAY [0...1517] OF BYTE
0x03	ERR_ADDE_FB_ETH_PDU_INVALID_SIZE Invalid Ethernet frame length at the ETH_PDU_DATA input/output. Permissible length: 18 ... 1518 Bytes

AXC 1050 (XC)

Table 7-10 Error codes of the "ADD_ERROR" input/output (ERROR output = TRUE)

Value	Description
0x04	ERR_ADDE_FB_ETH_LEN_INVALID The length of the Ethernet telegram length at the ETH_PDU_LEN output is larger than the buffer storage unit of the ETH_PDU_DATA input/output.
0x05	ERR_ADDE_FB_ETH_TOO_MANY_RECV_INSTANCES Too many instances of ETH_RECV function block. A maximum of ten instances of the function block are permitted.
0x07	ERR_ADDE_FB_ETH_WRONG_ETHTYPE Incorrect value in the type field (EtherType) of the Ethernet telegram

7.12 Functional blocks for Axioline F

7.12.1 Functional blocks for acyclic PDI communication

You can use the PDI communication blocks to carry out startup parameterization and online parameterization (parameterization during the runtime). However, PDI communication blocks are not necessarily required just for parameterization operations, they may also be required to operate special Axioline F modules (e.g., for an RS-232 special function module where the communication data is not exchanged between the controller and Axioline F module via process data but by means of objects via PDI). Because PDI is a connectionless protocol, no function blocks are required for connection establishment and release, i.e., function blocks only need to be implemented in the project to read and write PDI objects. There are PDI communication blocks available for this task.

Table 7-11 Overview of the IP communication blocks

Function block	Short description
PDI_READ	Reads PDI objects from local Axioline F devices
PDI_WRITE	Writes PDI objects to local Axioline F devices



The function blocks are described in the PC Worx (Express) online help.

7.12.2 AX_CONTROL function block

This function block allows you to send (request) firmware services to the Axioline F master and to receive confirmation for the purposes of configuring the Axioline F local bus.

Table 7-12 AX_CONTROL function block

Function block	Short description
AX_CONTROL	Sends firmware services to the Axioline F master



The function block is described in the PC Worx (Express) online help.

AXC 1050 (XC)**Firmware services**

For information on the firmware error messages and diagnostic registers of the Axioline F local bus master, refer to the UM EN AXL F SYS DIAG user manual.

All implemented firmware services of the Axioline F local bus can be removed using the AX_CONTROL function block, with the following exceptions:

- PDI_READ_OBJECT (0041_{hex})
- PDI_WRITE_OBJECT (0042_{hex})

The PDI_READ and PDI_WRITE function blocks are available for these services (see Section 7.12.1).

7.13 Function block for UTC

The function is available for the AXC 1050 (XC) with a firmware version ≥ 3.00 from AUTOMATIONWORX Software Suite 2017 Version 1.84 and later.

The GET_UTC_TIMESTAMP function block enables you to query the coordinated universal time UTC.

Function block

Figure 7-26 GET_UTC_TIMESTAMP function block

Input parameters

Table 7-13 ENABLE input of the GET_UTC_TIMESTAMP function block

Name	Data type	Description
ENABLE	BOOL	The function block is activated on a positive edge at this input. Every cycle, the function block provides the updated UTC. The function block remains active while the input has the TRUE status.

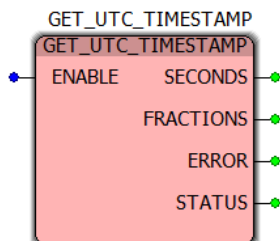
Output parameters

Table 7-14 Outputs of the GET.UTC_TIMESTAMP function block

Name	Data type	Description
SECONDS	DWORD	Seconds in the UTC
FRACTIONS	DWORD	Fractions of a second in the UTC
ERROR	BOOL	TRUE: An error has occurred FALSE: No error has occurred, the STATUS output provides error details
STATUS	UDINT	Error code of the error that has occurred (ERROR output = TRUE)

7.14 IP_INFO function block



The function is available for the AXC 1050 (XC) with a firmware version ≥ 3.00 from AUTOMATIONWORX Software Suite 2017 Version 1.84 and later.

The IP_INFO function block provides information about the current communication partner (IP address of the communication partner, port number, and communication protocol used).



The function block is described in the PC Worx (Express) online help.

7.15 Alignment

The alignment of the data elements in the controller memory can result in "data gaps" when storing data in the memory. The compiler automatically fills these gaps with padding bytes during the compilation process in order to prevent incorrect processing.

The disadvantage of the automatic filling of data gaps becomes apparent when data is transmitted from the controller to another controller. If this controller does not know the memory algorithm of the controller, it will interpret the received data incorrectly.

It is therefore useful to program the filling of data gaps in your application program. Alternatively, you can use the PACK and UNPACK function blocks (see online help in PC Worx). Data transmissions to other controllers can therefore be taken into consideration. For example, use byte arrays with an even number of bytes and/or word arrays in order to avoid data gaps in your application program.

Please observe the following notes for program creation:

- Create data types in flat structures, i.e., do not nest user-defined data types.
- Insert padding bytes manually in order to ensure the uniform size and layout of the data types.
- When inserting padding bytes, observe the memory alignment method of the controllers used in the application (1-byte, 2-byte or 4-byte alignment).

Program example with data gaps

The following program example shows how data gaps are filled.

```

1  TYPE
2  Struct1 :
3  STRUCT
4      ByteElement :  BYTE;
5      WordElement :  WORD;
6  END_STRUCT;
7
8  Struct2 :
9  STRUCT
10     WordElement :  WORD;
11     ByteElement :  BYTE;
12  END_STRUCT;
13
14  Struct3 :
15  STRUCT
16     ByteElement1  :  BYTE;
17     ByteElement2  :  BYTE;
18  END_STRUCT;
19
20  Struct4 :
21  STRUCT
22     Struct2Element :  Struct2;
23     Struct3Element :  Struct3;
24  END_STRUCT;
25
26  Array1 :  ARRAY [0..1] OF Struct2;
27  END_TYPE
    
```

Figure 7-27 Example programming

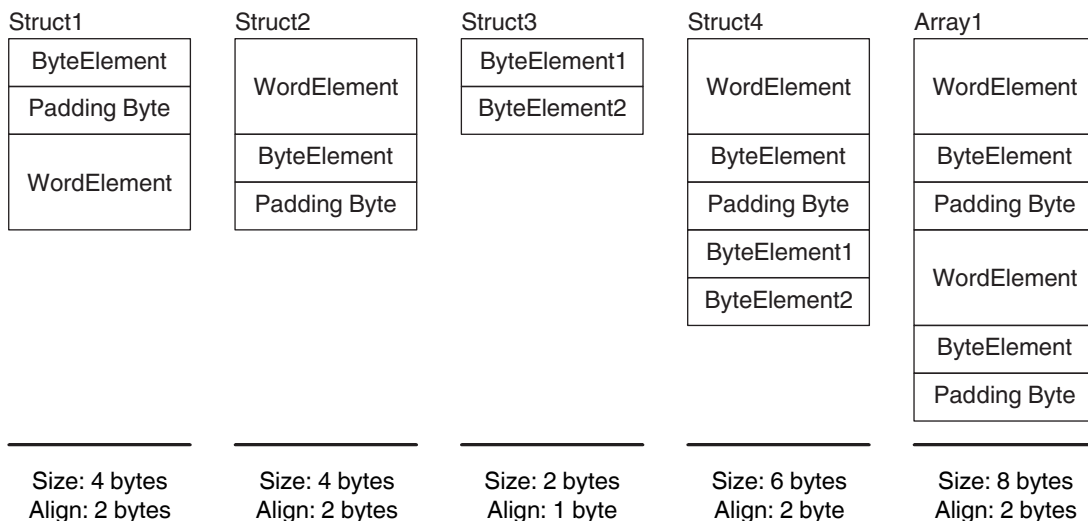

Figure 7-28 Alignment: padding bytes in data gaps

Struct1 receives a padding byte after the ByteElement so that the WordElement is at a WORD address (address that can be divided by two leaving no remainder). The alignment of the overall structure is based on the data type used with maximum alignment. In this case, the WordElement specifies the alignment.

AXC 1050 (XC)

The size of Struct2 is calculated based on the elements used and the resulting alignment. The corresponding number of padding bytes is inserted so that the size of the data type with the value of the alignment can be divided by two leaving no remainder (data type size modulo alignment = 0).

Struct3 does not receive any padding bytes as the maximum alignment corresponds to one byte.

Due to the padding byte that belongs to the Struct2 structure, the Struct3 structure starts at an even address in Struct4.

Array1 receives two padding bytes corresponding to two consecutive Struct2 structures.

Program example without data gaps

The following program shows an example of how to fill data gaps in your application program. Fill data gaps, which are to be expected due to the memory alignment, with application data (padding bytes in Figure 7-29).

```

1  TYPE
2  Struct1 :
3  STRUCT
4      ByteElement : BYTE;
5      ByteElement : BYTE; (*Padding-Byte*)
6      WordElement : WORD;
7  END_STRUCT;
8
9  Struct2 :
10 STRUCT
11     WordElement : WORD;
12     ByteElement : BYTE;
13     ByteElement : BYTE; (*Padding-Byte*)
14 END_STRUCT;
15
16 Struct3 :
17 STRUCT
18     ByteElement1 : BYTE;
19     ByteElement2 : BYTE;
20 END_STRUCT;
21
22 STRUCT4 :
23 STRUCT
24     Struct2Element : Struct2;
25     Struct3Element : Struct3;
26 END_STRUCT;
27
28 Array1 : ARRAY [0..1] OF Struct2;
29 END_TYPE

```

Figure 7-29 Example programming with padding bytes

8 System variables and status information

8.1 General notes

This section describes the special program functions of the PC Worx (Express) software that are available for the controller.

The controller has a register set, which is used for diagnostics and easy control of the controller and Axioline F local bus.

The diagnostic data is stored in the diagnostic status register and the diagnostic parameter register. These registers are available to the application program as system variables (system flags, global variables).

8.2 Diagnostic status register

Information on the operating state of the Axioline F local bus is stored in the diagnostic status register. A specific Axioline F local bus state is assigned to each bit in the diagnostic status register.

The following system variables can be used to read the diagnostic status register information.

Table 8-1 System variables of the diagnostic status register

System variable	Type	Meaning
AXIO_DIAG_STATUS_REG_HI	BYTE	Diagnostic status register (high byte)
AXIO_DIAG_STATUS_REG_LOW	BYTE	Diagnostic status register (low byte)
AXIO_DIAG_STATUS_REG_PF	BOOL	Peripheral fault
AXIO_DIAG_STATUS_REG_PW	BOOL	I/O warning
AXIO_DIAG_STATUS_REG_BUS	BOOL	Bus error
AXIO_DIAG_STATUS_REG_RUN	BOOL	Data transmission is active.
AXIO_DIAG_STATUS_REG_ACT	BOOL	Selected configuration is ready to operate.
AXIO_DIAG_STATUS_REG_RDY	BOOL	Axioline F local bus is ready to operate.
AXIO_DIAG_STATUS_REG_SYSFAIL	BOOL	The Axioline F local bus switches to the SYSFAIL state when the controller is in the STOP state or there is no program present on it.

8.3 Diagnostic parameter register

The diagnostic parameter register provides additional information on the error indicated in the diagnostic status register. The error code is stored in the diagnostic parameter register and the error location in the extended diagnostic parameter register. The error location is stored as a slot number. This starts at 1 and corresponds to the sequential number of the Axioline F modules that are installed one after another.



Exception: if an interface error cannot be located, the value 128 is displayed in the diagnostic parameter register (bit 7 is set).

The diagnostic parameter register is rewritten whenever an error occurs. If no interference has been detected, the diagnostic parameter register contains the value 0.

Table 8-2 System variables of the diagnostic parameter register

System variable	Type	Meaning
AXIO_DIAG_PARAM_REG_HI	BYTE	Diagnostic parameter register (high byte)
AXIO_DIAG_PARAM_REG_LOW	BYTE	Diagnostic parameter register (low byte)
AXIO_DIAG_PARAM_2_REG_HI	BYTE	Extended diagnostic parameter register (high byte)
AXIO_DIAG_PARAM_2_REG_LOW	BYTE	Extended diagnostic parameter register (low byte)

8.4 PROFINET system variables



The PC Worx Express software does not support this function.

Table 8-3 shows the PROFINET system variables of the integrated PROFINET controller functionality.

Table 8-3 PROFINET system variables (PROFINET controller functionality)

System variable	Type	Meaning
PNIO_SYSTEM_BF	BOOL	No connection to a configured PROFINET device An error has occurred in the PROFINET network, i.e., a connection could not be established to at least one configured PROFINET device. This value is not set if the "Control BF" parameter was set to FALSE for a PROFINET device. The PROFINET device has therefore been excluded from connection monitoring.
PNIO_SYSTEM_SF	BOOL	Diagnostic alarm on a configured PROFINET device At least one PROFINET device is indicating a system error (diagnostic alarm or maintenance alarm). The error priority can be determined from the PNIO_DIAG_AVAILABLE, PNIO_MAINTENANCE_DEMANDED, and PNIO_MAINTENANCE_REQUIRED variables.
PNIO_DIAG_AVAILABLE	BOOL	Diagnostics available At least one PROFINET device is indicating a diagnostic alarm for an active connection. The corresponding device(s) can be identified using the RALRM diagnostic block or by requesting the PN_DA_NO_DIAG diagnostic status byte of each PROFINET device. The application must decide, for example, whether outputs of the other PROFINET devices in the network may continue to be operated.
PNIO_MAINTENANCE_DEMANDED	BOOL	Maintenance demanded At least one PROFINET device is indicating the "maintenance demanded" alarm (high-priority maintenance alarm) for the active connection. The PROFINET device can be identified using the RALRM diagnostic block.
PNIO_MAINTENANCE_REQUIRED	BOOL	Maintenance required At least one PROFINET device is indicating the "maintenance required" alarm (low-priority maintenance alarm) for the active connection. The PROFINET device can be identified using the RALRM diagnostic block.
PNIO_FORCE_FAILSAFE	BOOL	All PROFINET devices are prompted to set their configured substitute values.
PNIO_CONFIG_STATUS	WORD	Configuration status of the PROFINET controller

AXC 1050 (XC)

Table 8-3 PROFINET system variables (PROFINET controller functionality)

System variable	Type	Meaning
PNIO_CONFIG_STATUS_READY	BOOL	This variable is set if the PROFINET controller has been initialized correctly. No desired configuration has been loaded by PC Worx yet.
PNIO_CONFIG_STATUS_ACTIVE	BOOL	This variable is set if the desired configuration for the PROFINET controller has been loaded. In this state the PROFINET controller attempts to establish a connection cyclically to all devices in the desired configuration (under the PROFINET icon).
PNIO_CONFIG_STATUS_CFG_FAULT	BOOL	The target PROFINET controller configuration has not been applied due to a serious error. In this case, please contact Phoenix Contact.

If one of these system variables is set, it is now possible to decide from the program whether the system should continue operating. System errors of the "Maintenance required" type and "Maintenance demanded" type can only lead to a message being sent to service personnel. The service personnel is advised of the error location, reason, and urgency.

Table 8-4 shows the PROFINET system variables of the integrated PROFINET device functionality.

Table 8-4 PROFINET system variables (PROFINET device function)

System variable	Type	Meaning
PND_S1_PLC_RUN	BOOL	Status of the higher-level PROFINET controller Information indicating whether the higher-level PROFINET controller is active. The value is TRUE if the higher-level PROFINET controller is in the RUN state (program is being processed). The display only applies when there is an existing PROFINET connection (PND_S1_VALID_DATA_CYCLE).
PND_S1_VALID_DATA_CYCLE	BOOL	The higher-level PROFINET controller has established the connection Information indicating whether a connection exists and cyclic data is being exchanged between the PROFINET controller and PROFINET device (AXC 1050 (XC)) and whether the last frame received contains valid data.
PND_S1_OUTPUT_STATUS_GOOD	BOOL	IOP status of the higher-level PROFINET controller Information indicating whether the input process data (PND_S1_INPUTS) was received by the PROFINET device with the "valid" status. The value is TRUE if the output data of the higher-level PROFINET controller is valid (provider status).
PND_S1_INPUT_STATUS_GOOD	BOOL	IOC status of the higher-level PROFINET controller
PND_S1_DATA_LENGTH	WORD	Process data length that was configured for the PROFINET device

System variables and status information

Table 8-4 PROFINET system variables (PROFINET device function)

System variable	Type	Meaning
PND_S1_OUTPUTS	PND_IO_256	Output process data Memory area for output process data that the PROFINET device sends to the higher-level PROFINET controller.
PND_S1_INPUTS	PND_IO_256	Input process data Memory area for input process data that the PROFINET device receives from the higher-level PROFINET controller.
PND_IO_DRIVEN_BY_PLC	INT	Applicative system redundancy Specifies from which higher-level PROFINET controller the data in the PROFINET device originates. "0": No PROFINET controller "1": PROFINET controller A "2": PROFINET controller B
PND_RESET_FACTORY_SETTINGS	WORD	Reset to Factory Settings/Default The following bits indicate which data/parameters are reset: Bit 0: Reserved Bit 1: Not supported; application data (Reset_APPLICATION_DATA) Bit 2: Supported; communication parameter (RESET_COMMUNICATION_PARAMETER) Bit 3: Not supported; configuration parameter (RESET_ENGINEERING_PARAMETER) Bit 4: Not supported; all saved parameters (RESET_ALL_PARAMETER) Bit 5 ... 7: Reserved Bit 8: Not supported; all saved parameters in the PROFINET controller/device (RESET_DEVICE) Bit 9: Not supported; firmware (RESET_FIRMWARE)

8.5 IEC-61131 runtime system

There is a separate group of system variables for the IEC-61131 runtime system.

Table 8-5 System variables of the IEC-61131 runtime system

System variable	Type	Meaning
PLCMODE_ON	BOOL	PLC status ON: The runtime system on the controller is ready to operate.
PLCMODE_LOADING	BOOL	PLC status LOADING: The application program is loading.
PLCMODE_RUN	BOOL	PLC status RUN: The application program is running.
PLCMODE_STOP	BOOL	PLC status STOP: The application program is currently not running.
PLCMODE_HALT	BOOL	PLC status HALT: The application program was stopped at an unspecified point.
PLCDEBUG_BPSET	BOOL	Breakpoint set: At least one breakpoint has been set in the application program.
PLCDEBUG_FORCE	BOOL	Variable(s) forced: At least one variable is being continuously overwritten (forced).
PLC_TICKS_PER_SEC	INT	System ticks per second: The number of pulses the system clock of the controller delivers per second.
PLC_SYS_TICK_CNT	DINT	Number of system ticks: The total number of pulses delivered by the system clock since the last startup.
PLC_TASK_AVAILABLE	INT	Number of available PLC tasks
PLC_SYSTASK_AVAILABLE	INT	Number of available system tasks
PLC_MAX_ERRORS	DINT	Maximum number of "errors, warnings, and logging events". If the maximum number is reached, the controller is stopped.
PLC_ERRORS	DINT	Number of "errors, warnings, and logging events" currently entered.
PLC_TASK_DEFINED	INT	Number of tasks used
PLC_TASK_1	RECORD	Information regarding task 1
:	:	:
PLC_TASK_8	RECORD	Information regarding task 8
CLOCK_PULSE_1S	BOOL	1 s clock pulse
CLOCK_PULSE_2S	BOOL	2 s clock pulse
CLOCK_PULSE_5S	BOOL	5 s clock pulse
CLOCK_PULSE_10S	BOOL	10 s clock pulse

System variables and status information

Table 8-5 System variables of the IEC-61131 runtime system

System variable	Type	Meaning
DISABLE_CLOCK_PULSE	BOOL	Deactivates the refresh function for the clock pulse variables If this variable is set, the CLOCK_PULSE_xS clock pulse variables are no longer refreshed. This reduces the processor capacity of the controller. FALSE: The CLOCK_PULSE_xS variables are refreshed (default setting). TRUE: The CLOCK_PULSE_xS variables are not refreshed.
LICENSE	DWORD	License information

8.6 Control processor

The system variables in Table 8-6 show the states of the diagnostic status register on the control processor of the controller.

Table 8-6 System variables of the control processor

System variable	Type	Meaning
COP_DIAG_STATUS_REG_RT_ERR	BOOL	A runtime error (out of real-time) has occurred on the control processor.
COP_DIAG_STATUS_REG_FAT_ERR	BOOL	A fatal error has occurred on the control processor. Division by zero, for example, leads to a fatal error.
COP_DIAG_STATUS_REG_WARN	BOOL	A warning has been issued on the control processor.
COP_DIAG_STATUS_REG_PON	BOOL	Power ON (COP): the control processor is ready to operate.
COP_DIAG_STATUS_REG_FC_RUN	BOOL	Runtime system RUN
COP_DIAG_STATUS_REG_FC_STOP	BOOL	Runtime system STOP
COP_DIAG_STATUS_REG_FC_HALT	BOOL	Runtime system HALT
COP_DIAG_STATUS_REG_FC_LDG	BOOL	Runtime system LOADING
COP_DIAG_STATUS_REG_FC_DBG	BOOL	Runtime system DEBUG
COP_DIAG_STATUS_REG_FC_RDO	BOOL	Runtime system READONLY
COP_DIAG_PARAM_REG	WORD	Diagnostic parameter register of the control processor
COP_DIAG_PARAM_2_REG	WORD	Extended diagnostic parameter register of the control processor

The system variable in Table 8-7 shows status information regarding the control processor of the controller.

Table 8-7 System variable of the control processor for displaying state information

System variable	Type	Meaning
COP_CPU_LOAD_WARNING	BOOL	The control processor is approaching its processor capacity limit.

AXC 1050 (XC)**8.7 Ethernet interfaces**

Table 8-8 System variables of the Ethernet interfaces

System variable	Type	Meaning
LAN_PORT1_1_LINK	BOOL	Link status of the Ethernet interface X1 TRUE: Connection established successfully (LINK) FALSE: Connection not established successfully
LAN_PORT1_2_LINK	BOOL	Link status of the Ethernet interface X2 TRUE: Connection established successfully (LINK) FALSE: Connection not established successfully

8.8 SD card

Table 8-9 System variable of the SD card

System variable	Type	Meaning
FLASHCARD_PRESENT	BOOL	Phoenix Contact SD card intended for use with AXC 1050 (XC) is inserted.

8.9 Energy storage, real-time clock

Table 8-10 System variables of the energy storage and real-time clock

System variable	Type	Meaning
RTC_BATTERY_LOW	BOOL	Low capacity of the energy storage for the real-time clock. TRUE: Energy storage device is being charged. FALSE: Energy storage device is fully charged. The charging process is complete.
RTC_DATA_INVALID	BOOL	The real-time clock data is invalid.

8.10 Power supplies

Table 8-11 System variables of the power supplies

System variable	Type	Meaning
POWER_SUPPLY_MAIN_OK	BOOL	The 24 V main power supply is OK.
UPS_BATTERY_OK	BOOL	The UPS battery is fully charged.

8.11 Mode selector switch

Table 8-12 System variables of the mode selector switch

System variable	Type	Meaning
KEY_SWITCH_RESET	BOOL	The mode selector switch is in the MRESET position.
KEY_SWITCH_STOP	BOOL	The mode selector switch is in the STOP position.
KEY_SWITCH_RUN_PROG	BOOL	The mode selector switch is in the RUN_PROG position

8.12 Project-related system variables

Table 8-13 Project-related system variables

System variable	Type	Meaning
PLC_HAS_PRJ_CMP_DATA	BOOL	The PC Worx project contains additional data for the "Online project comparison" function.
PLC_HAS_PRJ_BOOT	BOOL	A boot project is available.
IS_EXECUTING_BOOT_PROJECT	BOOL	The boot project is being executed.
IS_PRJ_RAM_AND_BOOT_CONSISTENT	BOOL	The project currently being executed is identical to the boot project.
PLC_HAS_PRJ_SRC	BOOL	Project sources are available on the controller.
PLC_PROJ_NAME	STRING	Project name and revision of the PC Worx project
PLC_CFG_NAME	STRING	Configuration name in PC Worx
PLC_RES_NAME	STRING	Standard resource name in PC Worx.
DC_AMOUNT	UDINT	Number of project changes that were successfully transferred to the controller.

8.13 System time

Table 8-14 System variables of the system time

System variable	Type	Meaning
RTC_HOURS	INT	System time (hours)
RTC_MINUTES	INT	System time (minutes)
RTC_SECONDS	INT	System time (seconds)
RTC_DAY	INT	System time (day)
RTC_MONTH	INT	System time (month)
RTC_YEAR	INT	System time (year)

9 Web-based management (WBM)



The WBM is available for the AXC 1050 (XC) with a firmware version ≥ 3.00 from AUTOMATIONWORX Software Suite 2017 Version 1.84 and later.

In the web-based management (WBM), you can access static and dynamic controller information and modify certain controller settings. The WBM can be called up via any of the controller's Ethernet interfaces.

9.1 Installing the WBM



If you use controllers with firmware versions ≥ 3.00 , you can skip this section. In this case, you can establish a connection to the WBM directly (see Section 9.2).

Proceed as follows to carry out initial installation of the WBM in controllers with firmware versions < 3.00 :

- Perform a firmware update to a firmware version ≥ 3.00 .
First, only install the firmware file *.fw.

You can either run the firmware update via FTP or using an SD card, also refer to Section "Performing updates" on page 150.

- When the update has been successfully completed, restart the controller.
- Then, install the *.wbm file after the firmware update.
- Restart the controller after the *.wbm file has been successfully installed on the controller.

You can now establish a connection with the WBM.

9.2 Establishing a connection with the WBM

To establish a connection with the WBM, proceed as follows:

- Open the web browser on your PC.
- In the address field, enter the URL "http://IP address of the controller/wbm" (example: http://192.168.0.2/wbm).

The WBM opens.



The WBM can only be called up if the controller has a valid IP address. By default, the controller has no valid IP address.

9.3 Changing the language

The WBM is available in German and English.

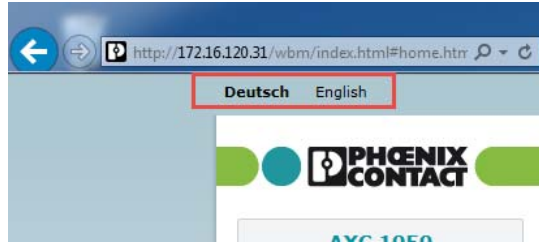

Figure 9-1 Changing the language

- Click the "Deutsch" or "English" link to change the language. The WBM then immediately switches to the desired language.

9.4 Areas and functions

The WBM is split into the following areas:

- "Information"
- "Diagnostics"
- "Administration"
- "WebVisu"

AXC 1050 (XC)

9.4.1 "Information" area

This area includes general device information.

9.4.1.1 "General Data" page

On the "General Data" page, you will find general details on the device, e.g., hardware and firmware versions and the order number as well as manufacturer details.

Deutsch **English**

Device Name: axc1050-1
 Project Name: UNTITLED

HW: 03 FW: 3.0.0.137

AXC 1050
2700988



Information

[General Data](#)

[Technical Data](#)

[Diagnostic Indicators](#)

Diagnostics

Administration

WebVisu

General Data

General Data	
Vendor	Phoenix Contact GmbH & Co. KG
Address	Flachmarktstr. 8, 32825 Blomberg, Germany
Internet	http://www.phoenixcontact.com
Type	AXC 1050
Order No.	2700988
Serial No.	1009876
Firmware Version	3.0.0.137
Runtime Version	3.0.9137.0
Hardware Version	03
FPGA Version	11B0
WBM-Version	3.0.0.10

IP-Settings	
LAN-Interface X1/X2	
DNS-Name	axc1050-1
IP-Address	172.16.120.31
Subnetmask	255.255.255.0
Default-Gateway	0.0.0.0
MAC-Address	00:A0:45:37:01:A8

Ethernet-Settings	
SNMP	activated
HTTP	activated
HTTPS	deactivated
FTP	activated
SNTP	
IP-Address SNTP-Server	10.11.4.252
MRP	deactivated

PROFINET	
PROFINET-Controller	deactivated
PROFINET-Device	deactivated

© 2017 PHOENIX CONTACT Licenses and Legal Information

Figure 9-2 "General Data" page

126 PHOENIX CONTACT

8482_en_03

DOWNLOADED FROM WWW.SCATTS.CO.UK

9.4.1.2 "Technical Data" page

The most important technical data for the controller is summarized on the "Technical Data" page.

Deutsch **English**

Device Name: axc1050-1
 Project Name: UNTITLED

HW: 03 FW: 3.0.0.137

AXC 1050
2700988



Information

General Data

Technical Data

Diagnostic Indicators

Diagnostics

Administration

WebVisu

Technical Data

General Data	
Ambient temperature (operation)	-25 °C ... 60 °C
Degree of protection	IP20
Protection class	III, IEC 61140, EN 61140, VDE 0140-1
Dimensions	45 mm x 125.9 mm x 74 mm (width x height x depth)
Note on dimensions	The depth is valid when a TH 35-7.5 DIN rail is used (according to EN 60715).

System limits of the plc	
Program memory	1 MB
Data memory	2 MB
Retain memory	48 KB
Number of supported Axioline F devices	max. 63 (per station)

Supply of the plc	
Power Supply at U _L	24 V DC
Maximum Permissible voltage range	19.2 V to 30 V DC (including all tolerances, including ripple)
Current Supply at U _{BUS}	2 A
Current Consumption from U _L	typ. 125 mA (without I/Os and U _L = 24 V) max. 550 mA

Interfaces	
Ethernet	2 Ports 10 BASE-T und 100 BASE-T(X), Auto Negotiation
Local bus	Axioline F
USB	1 Micro USB-Type B

For further information please refer to the data sheet at <http://www.phoenixcontact.com>

© 2017 PHOENIX CONTACT Licenses and Legal Information

Figure 9-3 "Technical Data" page

8482_en_03

PHOENIX CONTACT 127

DOWNLOADED FROM WWW.SCATTS.CO.UK

AXC 1050 (XC)

9.4.1.3 "Diagnostic Indicators" page

On the "Diagnostic Indicators" page, you will find a description of the LEDs and their possible states.

Deutsch **English**

Device Name: axc1050-1
 Project Name: UNTITLED
 HW: 03 FW: 3.0.0.137

AXC 1050
2700988

Information

General Data

Technical Data

Diagnostic Indicators

Diagnostics

Administration

WebVisu

Diagnostic Indicators

The following diagnostic indicator states are possible:

Designation	State	Description
PN: PROFINET controller/device function		
BF (Bus Fail PROFINET)	off	The AXC 1050 (XC)(PROFINET controller) has established an active communication connection to each configured PROFINET device and/or a PROFINET controller has established an active communication connection to the AXC 1050 (XC)(PROFINET device) or the PROFINET function is disabled.
	red on	No link status at Ethernet ports and/or no 100-Mbit transmission and/or no full duplex operation.
	flashing red	Link-Status ist vorhanden, zu mindestens einem projektierten PROFINET-Device besteht keine Kommunikationsverbindung und/oder zum PROFINET-Controller besteht keine Kommunikationsverbindung.
SF (Group error PROFINET SystemFail)	off	PROFINET diagnostics not present.
	red on	PROFINET diagnostics present.
ETH: Ethernet interfaces		
ETH LNK (Link)	off	Connection not established successfully
	green on	Connection established successfully (link): the controller is able to contact another network device.
	flashing green	PROFINET device identification "flashing"
ETH ACT (Activity)	off	Data transmission not active
	yellow on	Data transmission active (activity): the Ethernet interface is sending or receiving data

For further information please refer to the data sheet at <http://www.phoenixcontact.com>

Figure 9-4 "Diagnostic Indicators" page

9.4.2 "Diagnostics" area

In this area, you will find diagnostic information on the controller and the Axioline F local bus devices.

9.4.2.1 "Controller" page

On the "Controller" page, you will find a brief description of the current LED indicators of the controller during the runtime. If there is an error in the controller, an error code and error location are displayed.

Deutsch **English**

Device Name: axc1050-1
 Project Name: UNTITLED
 HW: 03 FW: 3.0.0.137

AXC 1050
2700988

+ Information

- Diagnostics

- [Controller](#)
- [Local Bus](#)
- [Diagnostic Archive](#)

+ Administration

WebVisu

Controller

Device	
RUN	Runtime system in RUN state
FAIL	No runtime error has occurred in the runtime system program
DBG	Runtime system is in normal mode
Additional Information	
Power Supply	OK
PROFINET	
BF	PROFINET function is disabled
SF	PROFINET diagnostics not present
SD card	
Total Volume	
Free Space	
Local bus	
D	Run: The Axioline F station is ready for operation, communication within the station is OK. All data is valid. There are no faults.
E	No error detected
Additional Information	
Error Code	0x0000
Error Location	0x0000
Buscycle	4.47 us

Figure 9-5 "Controller" page

AXC 1050 (XC)

9.4.2.2 "Local bus" page

All connected Axioline F local bus devices are displayed in an overview on the "Local bus" page. If you select an Axioline F local bus device, general specifications and diagnostic information are displayed for the Axioline F local bus device ("Module Information" view).

The screenshot shows the Phoenix Contact web interface for the 'Local bus' page. At the top, there are language options 'Deutsch' and 'English'. The Phoenix Contact logo is on the left, and the device name 'axc1050-1' and project name 'UNTITLED' are on the right. Below the logo, the device name 'AXC 1050' and serial number '2700988' are displayed next to an image of the device. The main content area is titled 'Local bus' and contains a table with the following data:

No.	Product Name	Product Text	Location	Equipment Identifier
0	AXC 1050	-	-	-
1	AXL DO 32/1-ME	32 digital outputs		
2	AXL DI 16/1-ME	16 digital inputs, adjustable filter	Please fill in ...	Please fill in ...
3	AXL DI 32/1-ME	32 digital inputs, adjustable filter	Please fill in ...	Please fill in ...

On the left side, there is a sidebar with navigation options: '+ Information', '- Diagnostics' (with sub-links for 'Controller', 'Local Bus', and 'Diagnostic Archive'), '+ Administration', and 'WebVisu'.

© 2017 PHOENIX CONTACT Licenses and Legal Information

Figure 9-6 "Local bus" page: overview of the Axioline F local bus devices

- Click on the entry in the "No." or "Product Name" column of the Axioline F local bus device row to open the "Module Information" view.

The "Module Information" view opens.

Module Information	
Local bus	
Status	Ok
General Data	
Module Number	2
Vendor Name	Phoenix Contact
Product Name	AXL DI 16/1-ME
Product Text	16 digital inputs, adjustable filter
Order Number	2688323
Serial Number	2031915286
Hardware Version	2011-05-18 00
Firmware Version	0000-00-00 --
User Defined	
Location	Please fill in ...
Equipment Identifier	Please fill in ...
Application Device Address	1
Peripheral Error	
Diagnostic State - Cons. No.	0
Diagnostic State - Priority	0x00
Diagnostic State - Channel/Group /Module	0
Diagnostic State - Code	0x0000
Diagnostic State - Text	

[Close](#)

Figure 9-7 "Local bus" page: "Module Information" view

In the "Module Information" view, in addition to general information on the selected Axioline F module (e. g. hardware/firmware version, order number, etc.), you will find user-defined information. If there is an error in the Axioline F module, diagnostic information on the error is displayed.

AXC 1050 (XC)

9.4.2.3 "Diagnostic Archive" page

All diagnostic messages and operating states of the controller are displayed on the "Diagnostic Archive" page.

The screenshot displays the 'Diagnostic Archive' page for a Phoenix Contact AXC 1050 controller. The page includes a navigation menu on the left with sections for Information, Diagnostics, Administration, and WebVisu. The Diagnostics section is expanded to show 'Controller', 'Local Bus', and 'Diagnostic Archive'. The main content area features a table of diagnostic messages.

	Message	Time	System
i	Diagnostic archive saved	12.04.2017 09:05:57	System
i	Controller has changed to RUN state.	12.04.2017 08:36:00	PLC
i	Run	12.04.2017 08:36:00	Axioline F
i	Active	12.04.2017 08:36:00	Axioline F
i	Controller started	12.04.2017 08:35:59	PLC
i	Ready	12.04.2017 08:35:59	Axioline F
i	Switch on the controller has been set to RUN/PROG position.	12.04.2017 08:35:59	PLC
i	Charging of buffer battery started	12.04.2017 08:35:59	System

At the bottom of the page, there is a button labeled 'Refresh Diagnostic Archive'.

© 2017 PHOENIX CONTACT Licenses and Legal Information

Figure 9-8 "Diagnostic Archive" page

- Click the "Refresh Diagnostic Archive" button to refresh the display.

9.4.3 "Administration" area

In this area, you can assign a password for restoring the factory default settings on the controller and view information on running updates (e. g. firmware update, WBM update, etc.).

9.4.3.1 "Password" page

On the "Password" page, you can assign a password for restoring the factory default settings on the controller (refer also to Section 9.4.3.2, "Factory Defaults" page).



Please note:

The password is sent to the network in an unencrypted format.

© 2017 PHOENIX CONTACT Licenses and Legal Information

Figure 9-9 "Password" page

AXC 1050 (XC)

- Enter the desired new password in the "Enter New Password" input field.

Permissible characters:

- a ... z
- A ... Z
- 0 ... 9
- Special characters
- Umlauts



The password must be between four and twelve characters long.

Recommended:

- Use a combination of upper-case letters, lower-case letters, and digits for the password.

- Re-enter the desired new password in the "Re-Enter New Password" input field.
- Enter the current password in the "Enter Old Password" input field.



When you create a new password for the first time, you have to enter the default password of the controller in the "Enter Old Password" input field. The default password is private.

- Click on "Apply" to save the new password.

9.4.3.2 "Factory Defaults" page

On the "Factory Defaults" page, you can restore the factory default settings on the controller or restart the controller without restoring the factory default settings. This requires a password (refer also to Section 9.4.3.1, "Password" page").

The screenshot shows the Phoenix Contact web-based management interface. At the top, there are language options for 'Deutsch' and 'English'. The Phoenix Contact logo is on the left, and device information is on the right: 'Device Name: axc1050-1' and 'Project Name: UNTITLED'. Below the logo, the device model 'AXC 1050 2700988' is displayed with an image of the device. The main heading is 'Factory Defaults'. An attention message states: 'Attention: This operation erases all your settings and password information and resets the device to its default settings. You will have to reconfigure the device and set a new password. For more information about this please refer to the data sheet.' Below this, there is a 'Reset the Device' section with a checkbox for 'Reset to factory default settings'. An 'Enter password' input field is provided. A blue 'Apply and Restart' button is located at the bottom right of the main content area. A left-hand navigation menu includes 'Information', 'Diagnostics', 'Administration' (with sub-items: 'Password', 'Factory Defaults', 'Updates via SD card'), and 'WebVisu'.

© 2017 PHOENIX CONTACT Licenses and Legal Information

Figure 9-10 "Factory Defaults" page

Restoring the factory defaults

- Activate the check box "Reset to factory default settings".
- Enter the password in the "Enter password" input field.



If you have not changed the password, you have to enter the default password. The default password is private.

- Click on "Apply and Restart".

The controller is then restored to the factory default settings and restarted automatically.



Please note:

When restoring the factory default settings, all application-specific data (PC Worx (Express) project, IP settings, password, etc.) for the controller is deleted. After restoring the settings, you must reconfigure the controller and assign a new password.

AXC 1050 (XC)

Restarting the controller

- Deactivate the check box "Reset to factory default settings".
- Enter the password in the "Enter password" input field.



If you have not changed the password, you have to enter the default password. The default password is private.

- Click on "Apply and Restart".

The controller is restarted.

9.4.3.3 "Updates via SD card" page

On the "Updates via SD card", you will find information on running controller updates.

Deutsch **English**

Device Name: axc1050-1
 Project Name: UNTITLED

HW: 03 FW: 3.0.0.137

Updates via SD card

AXC 1050
2700988

+ Information

+ Diagnostics

- Administration

Password

Factory Defaults

[Updates via SD card](#)

WebVisu

Please note:
You need an SD card recommended by Phoenix Contact to perform updates (e.g. firmware updates, WBM updates, etc.).

To update the controller, proceed as follows:

- Disconnect the power to the controller.

Operation with an SD card If you use the controller with an SD card as main or as additional memory:

- Remove the SD card.

Performing the update

- Insert an SD card recommended by Phoenix Contact into an SD card reader and connect the card reader to your PC.
- In the root directory of the SD card, create the systemupdate directory.
- Download the *.exe update file from phoenixcontact.net/products on the page of the controller.
- Run the *.exe update file.
- Follow the instructions of the installation wizard.

During installation, a directory containing the update files is created in the selected memory location.

- Save the update files (one or more files of following file types: *.fw, *.wbm, *.fpga, *.boot) to the systemupdate directory on the SD card.
- Insert the SD card into the controller.
- Switch on the supply voltage.

The update is performed automatically.

When the update is complete, the BF, SF, RUN and FAIL LEDs all flash simultaneously at a frequency of 1 Hz.

When the update is complete, you need to remove the SD card and restart the controller:

- Disconnect the power to the controller.
- Remove the SD card.

Operation with an SD card If the SD card used for updating is the same you had previously been using as main or additional memory:

- Delete the systemupdate directory from the SD card.
- Insert the SD card back into the controller.
- Switch on the supply voltage.

If you used a different SD card for updating:

- Insert the SD card you had previously been using as main or additional memory back into the controller.
- Switch on the supply voltage.

Operation without an SD card If you had been using the controller without an SD card before updating:

- Switch on the supply voltage.

© 2017 PHOENIX CONTACT Licenses and Legal Information

Figure 9-11 "Updates via SD card" page

AXC 1050 (XC)

9.4.4 "WebVisu" area

This area contains a link that you can use to open the WebVisit project of the controller.

- Click the "WebVisu" link.



© 2017 PHOENIX CONTACT Licenses and Legal Information

Figure 9-12 "WebVisu" link

If there is a WebVisit project on the controller, the visualization project is opened in the browser.

Proceed as follows to switch back from the visualization project to the WBM within the browser:

- In the address field of the browser, enter the URL "http://IP address of the controller/wbm" (example: http://192.168.0.2/wbm).

The WBM opens.

10 Removing hardware



For basic information about the Axioline F system and its installation, particularly mounting/removing Axioline F modules, please refer to the UM EN AXL F SYS INST user manual ("Axioline F: system and installation").

10.1 Safety notes



NOTE: Electrostatic discharge!

The device contains components that can be damaged or destroyed by electrostatic discharge. When handling the device, observe the necessary safety precautions against electrostatic discharge (ESD) according to EN 61340-5-1 and IEC 61340-5-1.



NOTE: Electrical damage due to inadequate external protection – No safe fuse trip in the event of an error

The electronics in the device are damaged due to inadequate external protection.

- Protect the supply voltage externally in accordance with the connected load (number of Axioline F devices/amount of logic current consumption for each device).
- Make sure the external fuse blows safely in the event of an error.



NOTE: Damage to the contacts when tilting

If the controller/modules tilt, you can damage the contacts.

- Remove the controller/modules, keeping them **perpendicular** to the DIN rail when doing so.



Please note:

- During all work on the Axioline F station, the controller or a module, switch off the power supply to the Axioline F station and make sure the supply voltage is protected against unauthorized re-activation.

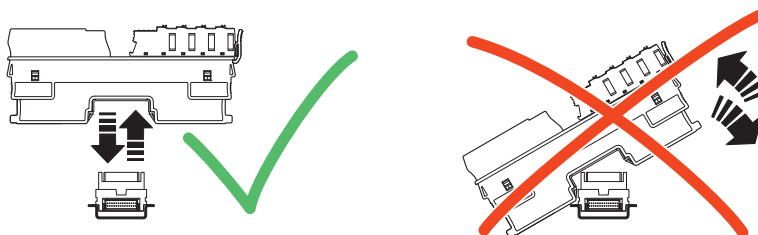

Figure 10-1 Removing the module so that it is **perpendicular** to the DIN rail

10.2 Removing cables

- Disconnect the power to the station.

The cables should only ever be removed from the supply plug if you wish to change the terminal point assignment or no longer wish to use the supply plug.

- Open the spring by pressing on the spring lever with a screwdriver (A in Figure 10-2).
- Remove the cable (B in Figure 10-2).

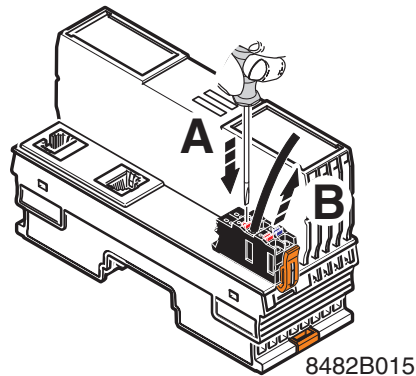

Figure 10-2 Removing the cable

10.3 Removing the plug

Removing the supply plug

- Release the locking latch (A in Figure 10-3), tilt the plug upwards slightly (B in Figure 10-3), and remove it from the controller (C in Figure 10-3).

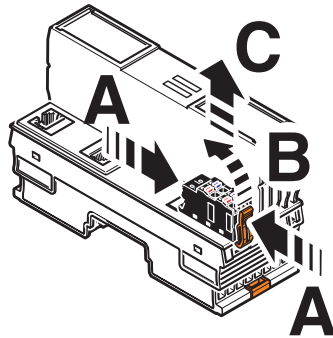

Figure 10-3 Removing the supply plug

Removing the Ethernet connector

- Release the RJ45 connector by pressing on the snap-in latch and remove the connector.

Removing the USB plug

- Pull the USB plug out.

10.4 Removing the SD card

- Lightly push the SD card far enough into the SD card holder until the snap-on mechanism releases the SD card and partially ejects the SD card from the SD card holder.
- Remove the SD card.

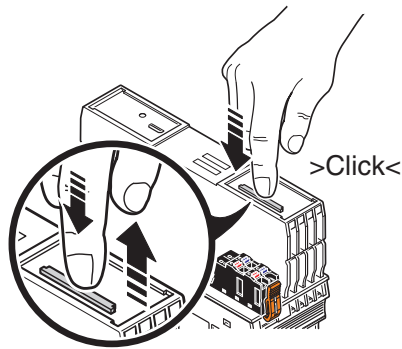

8482A021

Figure 10-4 Removing the SD card

10.5 Removing the controller

- Insert a suitable tool (e.g., bladed screwdriver) into the upper and lower snap-on mechanisms (base latches) of the controller one after the other and release it (A in Figure 10-5).

The base latches are locked in place in the open position.

- Remove the controller perpendicular to the DIN rail (B in Figure 10-5).

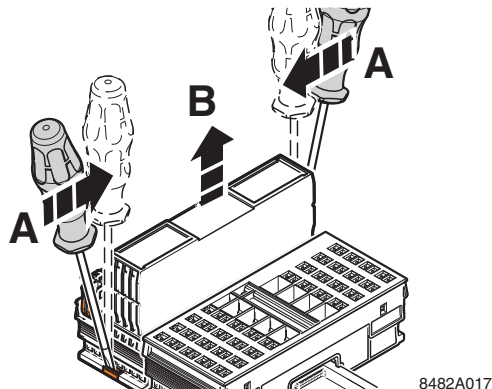

8482A017

Figure 10-5 Removing the controller

11 After usage

11.1 Maintenance and servicing

The controller is maintenance-free.

11.2 Device replacement

The controller can be replaced as required.

- Replace the controller in your application with an identical controller (same order number).

If you want to replace a controller, follow the steps described in Section 4, "Mounting hardware" and Section 10, "Removing hardware".

- Once replaced, restore all the necessary connections.

Observe the following when replacing a controller (**BootP server**):

If you want to use the BootP server to assign the IP address settings of the controller, enter the MAC address and IP address of the controller in the PC Worx (Express) software.



Refer to the information in Section "BootP server" on page 52.



If you operate the controller with the SD card as the main memory:

All application-specific data (WebVisit projects, PC Worx projects, IP settings, etc.) is stored on the SD card. When the SD card is inserted in the new controller, this data is immediately available after the controller initialization phase.

For additional information on operating the controller with the SD card as the main memory, please refer to Section 6.8.1 on page 72.

11.3 Device defect and repair

Repairs may only be carried out by Phoenix Contact.

- Send defective devices back to Phoenix Contact for repairs or to receive a replacement device.
- We strongly recommend using the original packaging to return equipment.
- Include a note on the packaging indicating that the contents are returned goods.
- If the original packaging is no longer available, observe the following points:
 - Observe the humidity specifications and the temperature range specified for transport (see Section "Technical data" on page 144).
 - If necessary, use dehumidifying agents.
 - Use appropriate ESD packaging to protect components that are sensitive to electrostatic discharge.
 - Secure any loose parts.
 - Make sure that the packaging you select is large enough and sufficiently thick.
 - Only use plastic bubble wrap sheets as wadding.
 - Attach warnings to the transport packaging so that they are clearly visible.
 - Please be aware that the delivery note is to be placed inside the package in the case of packages that are to remain within the same country. However, if the package is being sent abroad, the delivery note must be placed inside a delivery note pocket and attached to the outside so that it is clearly visible.

11.4 Disposal

Controller disposal

- Do not dispose of the device with household waste; it should instead be disposed of in accordance with the currently applicable national regulations.

Packaging disposal

- Dispose of packaging materials that are no longer needed (cardboard packaging, paper, bubble wrap sheets, etc.) with household waste in accordance with the currently applicable national regulations.

AXC 1050 (XC)

12 Technical data and ordering data

12.1 Technical data

Dimensions (nominal sizes in mm)

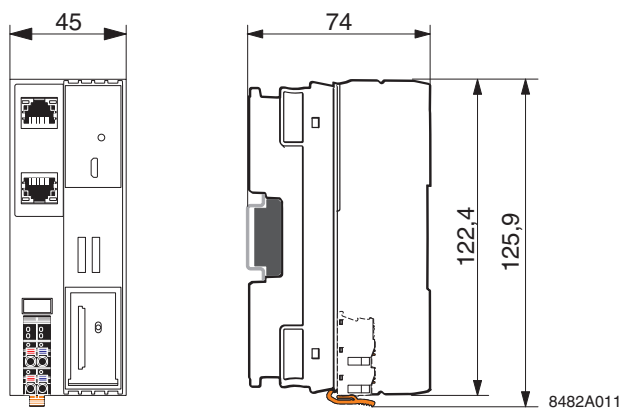

Width	45 mm
Height	125.9 mm
Depth	74 mm
Note on dimensions	The specified depth applies when using a TH 35-7.5 DIN rail (according to EN 60715), e.g., NS 35/7.5, etc., from Phoenix Contact, see "Ordering data" on page 148.

General data

Color	Traffic gray A RAL 7042
Weight	195 g, approximately (including bus base module and supply plug)
Degree of protection	IP20 (EN 60529:1991)
Protection class	III, IEC 61140, EN 61140, VDE 0140-1
Coated PCBs	AXC 1050 XC only

System limits of the controller

Amount of process data	8192 bits, maximum (per station) 4096 bits, maximum (input) 4096 bits, maximum (output)
Number of supported devices	63, maximum (per station)

Axioline F local bus interface

Connection method	Connection for bus base module
Transmission speed	100 Mbps

Axioline F local bus interface

Electrical isolation	No
Number of devices	63, maximum

**NOTE: Electronics may be damaged if overloaded**

Observe the logic current consumption of each device when configuring an Axioline F station. This is specified in every module-specific data sheet. The current consumption can differ depending on the individual module. The permissible number of devices that can be connected therefore depends on the specific station structure.

General feed-in supply

Use a **power supply without fall-back characteristic curve** (see Section "Sizing of the power supply" on page 43).

Controller supply

Communications feed-in communications power U_L	24 V DC
Maximum permissible voltage range	19.2 V DC ... 30 V DC (including all tolerances, ripple included)
Ripple	±5 %
Current consumption from U_L	Typically 125 mA (without I/Os and $U_L = 24$ V) Max. 550 mA (with 2 A at U_{BUS} for the I/Os and $U_L = 24$ V)
Power consumption at U_L	Typically 3 W (without I/Os) Max. 13.2 W (with 2 A load at U_{BUS} for the I/Os)
Power supply at U_{BUS}	2 A
Protective measures	
Surge voltage	Input protective diode, pulse load up to 1500 W
Reverse polarity	Serial diode in the lead path of the power supply unit; in the event of an error only a low current flows. In the event of an error, no fuse trips within the external power supply unit.

**NOTE: Electrical damage due to inadequate external protection – no safe fuse trip in the event of an error**

Protect the supply voltage externally in accordance with the connected load (number of Axioline F devices/amount of logic current consumption for each device). Make sure the external fuse blows safely in the event of an error.

Connection data

Please observe the information provided on conductor cross sections in the "Axioline F: System and installation" user manual.

Designation	Axioline F plug
Connection method	Push-in connection
Conductor cross section solid	0.2 mm ² ... 1.5 mm ²
Conductor cross section flexible	0.2 mm ² ... 1.5 mm ²
Conductor cross section [AWG]	24 ... 16
Stripping length	8 mm

AXC 1050 (XC)**PROFINET**

Type	PROFINET controller/device
Number of supported devices	Max. 16 (on the PROFINET controller)
Specification	2.3
Conformance class	A
Performance class	RT
Update rate	
16 devices	32 ms
8 devices	32 ms
4 devices	16 ms
2 devices	8 ms
1 device	4 ms
Number of slots	1
Vendor ID	00B0 _{hex} /176 _{dec}
Device ID	0093 _{hex} /122 _{dec}

Network interface

Type	2 x Ethernet; 10Base-T and 100Base-T(X)
Transmission speed	10 Mbps (10BASE-T), 100 Mbps (100BASE-T(X)) half duplex, full duplex, auto negotiation



This speed cannot be set manually. It is set automatically by means of auto negotiation.

Connection technology	CAT5 twisted pair cable Twisted pair cable with a conductor cross section of 0.14 mm ² to 0.22 mm ² 8-pos. RJ45 socket
-----------------------	--

USB interface

Connection technology	Micro-USB type B
Interface type	COM port emulation
Transmission rate	max. 115.2 kbps

Diagnostics and status indicators

IEC 61131 runtime system (PLC)	RUN, FAIL, DBG
Ethernet (ETH)	LINK, ACT
Axioline F diagnostics	D, E
Supply voltages	UL
PROFINET	BF, SF

IEC-61131 runtime system

Programming system	PC Worx/PC Worx Express
CPU (Central Processing Unit)	Nios [®] II (softcore processor), 100 MHz
Shortest cycle time (for cyclic task)	1 ms
Program memory	1 MB, 86 K instructions (IL)
Mass storage	2 MB

Technical data and ordering data

IEC-61131 runtime system

Retentive mass storage	48 kB, NVRAM
Number of data blocks	Depends on mass storage
Number of control tasks	8
Parameterization memory	
Integrated	4 MB flash storage (typically 100,000 write access operations per sector)
Pluggable, SD card	512 MB/2 GB (typically 1,000,000 write access operations per sector), see Section "Accessories" on page 148

Please note:

The number of write access operations is limited.

Real-time clock

Accuracy	1.73 s/day = 20 ppm at 25°C
Power reserve	10 days

UPS

Buffer time in the event of voltage interruptions	2 s
---	-----

Ambient conditions

	AXC 1050	AXC 1050 XC
Degree of protection	IP20 (EN 60529:1991)	
Ambient temperature (operation)	-25°C ... +60°C (up to 2000 m above mean sea level) -25°C ... +55°C (up to 3000 m above mean sea level)	-40°C ... +70°C (up to 2000 m above mean sea level) -40°C ... +65°C (up to 3000 m above mean sea level) For derating information, see Section "Derating for the controller AXC 1050 XC" on page 152. For additional information on use of the controller in extreme ambient conditions, refer to Section "Tested successfully: Use under extreme ambient conditions" on page 153.



The temperature range is only guaranteed if the Axioline F controller is mounted horizontally.

Permissible temperature (storage/transport)	-40°C ... +85°C
Permissible humidity (operation/storage/transport)	10% ... 95%, according to DIN EN 61131-2, non-condensing, no ice formation
Permissible air pressure (operation)	70 kPa ... 106 kPa (up to 3000 m above sea level)
Permissible air pressure (storage/transport)	58 kPa ... 106 kPa (up to 4500 m above sea level)

Mechanical tests

Vibration resistance according to IEC 60068-2-6	5g
Shock according to EN 60068-2-27/IEC 60068-2-27	30g
Continuous shock according to EN 60068-2-27/IEC 60068-2-27	10g
Broadband noise according to DIN EN 61373	0.5g

AXC 1050 (XC)**Conformity with EMC Directive 2014/30/EU****Immunity test according to EN 61000-6-2**

Electrostatic discharge (ESD)	EN 61000-4-2/ IEC 61000-4-2	Criterion B 6 kV contact discharge 8 kV air discharge
Electromagnetic fields	EN 61000-4-3 IEC 61000-4-3	Criterion A Field strength: 10 V/m
Fast transients (burst)	EN 61000-4-4/ IEC 61000-4-4	Criterion B Supply lines: 2 kV Signal/data lines: 2 kV
Surge test	EN 61000-4-5 IEC 61000-4-5	Criterion B Signal/data lines: 1 kV Supply lines: 0.5 kV
Conducted disturbance variables	EN 61000-4-6 IEC 61000-4-6	Criterion A Test voltage: 10 V

Noise emission test according to EN 61000-6-3

Noise emission	EN 55022	Class B
----------------	----------	---------

Approvals

For the latest approvals, please visit phoenixcontact.net/products.

12.2 Ordering data**12.2.1 Controller**

Description	Type	Order No.	Pcs. / Pkt.
Axiocontrol for the direct control of Axioline F I/Os. With 2 Ethernet interfaces and programming capabilities according to IEC 61131-3. Complete with connector and marking field.	AXC 1050	2700988	1
Axiocontrol for the direct control of Axioline F I/Os. With 2 Ethernet interfaces and programming capabilities according to IEC 61131-3. Complete with connector and marking field.	AXC 1050 XC	2701295	1

12.2.2 Accessories

Description	Type	Order No.	Pcs. / Pkt.
Axioline F bus base module	AXL F BS BK	2701422	5
Axioline F short power connector (for devices such as AXL F BK, etc.) (replacement item)	AXL CN S/UL	2701421	5
AX OPC SERVER, communication interface for OPC-compatible visualization with PC Worx-based controllers	AX OPC Server	2985945	1
Program and configuration memory, pluggable, 512 MB.	SD FLASH 512 MB	2988146	1
Program and configuration memory, pluggable, 512 MB with license key for function block libraries, e.g., for: SNMP, SQL, wireless, motion functions, etc.	SD FLASH 512 MB APPLIC A	2701799	1
Program and configuration memory, pluggable, 512 MB with license key for licensing the PDPI-BASIC function block for precise multi-channel controllers with self-optimization, e.g., for heating and cooling functions or hydraulic movements.	SD FLASH 512MB PDPI BASIC	2701800	1

Technical data and ordering data

Description	Type	Order No.	Pcs. / Pkt.
Program and configuration memory, pluggable, 512 MB with license key for licensing the PDPI-PRO function block for precise multi-channel controllers with self-optimization; additional functions: e.g., for setpoint processing, for heating and cooling functions.	SD FLASH 512 MB PDPI PRO	2701801	1
Program and configuration memory, pluggable, 2 GB	SD FLASH 2 GB	2988162	1
Program and configuration memory, pluggable, 2 GB with license key for function block libraries, e.g., for: SNMP, SQL, wireless, motion functions, etc.	SD FLASH 2 GB APPLIC A	2701190	1
Program and configuration memory, pluggable, 2 GB with license key for webMI from atvise®	SD FLASH 2 GB ATWISE	2400088	1
Program and configuration memory, pluggable, 2 GB with license key for function block libraries, e.g., for webMI from atvise®, SNMP, SQL, wireless, motion functions, etc.	SD FLASH 2 GB APPLIC A ATWISE	2400089	1
Program and configuration memory, pluggable, 2 GB with license key for IEC-61850 communication	SD FLASH 2 GB 61850	2400435	1
Program and configuration memory, pluggable, 2 GB with license key for IEC-61850 communication and for function block libraries, e.g., SNMP, SQL, wireless, motion functions, etc.	SD FLASH 2 GB APPLIC A 61850	2400436	
Connecting cable for connecting the controller to a PC for PC Worx, USB A to micro USB B, 2 m in length.	CAB-USB A/MICRO USB B/2,0M	2701626	1
QUINT POWER power supplies	See latest Phoenix Contact catalog		

12.2.3 Software

Description	Type	Order No.	Pcs. / Pkt.
PC Worx Express automation software	PC WORX EXPRESS	2988670	1
PC Worx automation software	See latest Phoenix Contact catalog		

12.2.4 Documentation

Description	Type	Order No.	Pcs. / Pkt.
"Devices from the Axioline F product group for use in zone 2 potentially explosive areas" application note	AH EN AXC/AXL F EX ZONE 2	–	1
"Modbus/TCP with Phoenix Contact controllers" application note	AH EN MODBUS/TCP	–	1
"Axioline F: system and installation" user manual	UM EN AXL F SYS INST	–	1
"Axioline F: diagnostic registers and error messages" user manual	UM EN AXL F SYS DIAG	–	1
"Starting up Axioline under PC Worx (for experienced PC Worx users)" application note	AH EN PC WORX – AXL PRO	–	1
"IEC-61850 configuration of a Phoenix Contact IED" user manual	UM EN PHOENIX CONTACT IEDs – IEC 61850	–	1
"Measures to protect network-capable devices with Ethernet connection against unauthorized access" application note	AH EN INDUSTRIAL SECURITY	–	1
"PC Worx Express Version 5.20 or later" quick start guide	UM QS EN PC WORX EXPRESS	–	1
"PC Worx Version 6.10 or later" quick start guide	UM QS EN PC WORX	–	1
"PROFINET basics" user manual	UM EN PROFINET SYS	–	1
"PROFINET controller/device functions" user manual	UM EN PROFINET CTRL DEV	–	1
"Applicative system redundancy" application note	AH EN APPLICATIVE SYSTEM REDUNDANCY	–	1
"Using the atvise® builder software with modular small-scale controllers of type ILC 1x1 and AXC 1050 (XC)" application note	AH EN ILC 1X1, AXC 1050/(XC) – ATWISE	–	1

A Appendix

A 1 Performing updates

A 1.1 Performing updates via FTP

The controller firmware can be updated via FTP access using the Ethernet interface.



To update the firmware, please proceed as described in the "Firmware update ILC 1.../3..., RFC 4..." application note. It can be downloaded at phoenixcontact.net/products.

A 1.2 Performing updates via an SD card



The function is available for controllers with firmware versions ≥ 3.00 .



Please note:

You need an SD card recommended by Phoenix Contact to perform updates (such as firmware updates, WBM updates, etc.) (see Section "Ordering data" on page 148).

To update the controller, proceed as follows:

- Disconnect the power to the controller.

Operation with an SD card

If you use the controller with an SD card as main or as additional memory:

- Remove the SD card.

Performing the update

- Insert an SD card recommended by Phoenix Contact into an SD card reader and connect the card reader to your PC.
- In the root directory of the SD card, create the "systemupdate" directory.
- Download the *.exe update file from phoenixcontact.net/products on the page of the controller.
- Run the *.exe update file.
- Follow the instructions of the installation wizard.

During installation, a directory containing the update files is created in the selected memory location.

- Save the update files (one or more files of the following file types: *.fw, *.wbm, *.fpga, *.boot) to the "systemupdate" directory on the SD card.
- Insert the SD card into the controller.
- Switch on the supply voltage.

The update is performed automatically.

When the update is complete, the BF, SF, RUN, and FAIL LEDs all flash simultaneously at a frequency of 1 Hz.

When the update is complete, you need to remove the SD card and restart the controller.

- Disconnect the power to the controller.

- Remove the SD card.

Operation with an SD card

If the SD card used for updating is the same you had previously been using as main or additional memory:

- Delete the "systemupdate" directory from the SD card.
- Insert the SD card back into the controller.
- Switch on the supply voltage.

If you used a different SD card for updating:

- Insert the SD card that had previously been used as main or additional memory back into the controller.
- Switch on the supply voltage.

Operation without an SD card

If you had been using the controller without an SD card before updating:

- Switch on the supply voltage.

A 2 Derating for the controller AXC 1050 XC

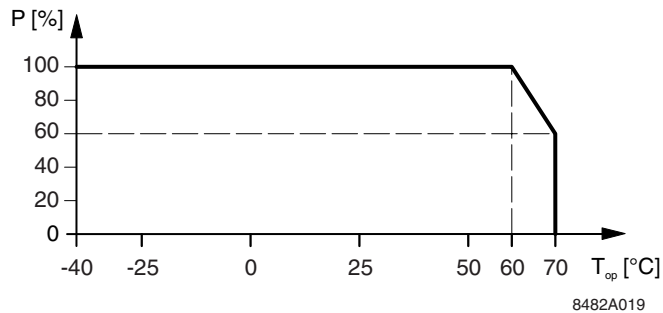

Figure A-1 Derating for the AXC 1050 XC

Key:

P [%] Power dissipation as a percentage

T_{op} [°C] Ambient temperature (operation) in °C

The specifications refer to a supply voltage of 24 V.

When working with a higher voltage (e.g., 30 V), the percentage values increase. In this case, multiply the percentage values by 1.25 ($30\text{ V}/24\text{ V} = 1.25$).

The derating is controlled by the power consumption of the modules connected to the Axioline F local bus. At an ambient temperature of up to +60°C, a maximum of 2 A is available for the modules connected to the Axioline F local bus. At +70°C, this drops to just 60% of 2 A in accordance with Figure A-1. For information on the power consumption of the Axioline F modules, please consult the module-specific user documentation.

Tested successfully: Use under extreme ambient conditions

A 3 Tested successfully: Use under extreme ambient conditions

The AXC 1050 XC controller has been tested successfully over 250 temperature change cycles according to IEC 61131-2 in the range from -40°C to $+70^{\circ}\text{C}$.

The following conditions were observed:

- The Axioline F devices for all connecting cables were wired with a minimum conductor cross section of 0.5 mm^2 .
- The controller was installed on a wall-mounted horizontal DIN rail.
- Fans were used to ensure continuous movement of air in the control cabinet.
- The controller was not exposed to vibration or shock.
- The controller was operated with a maximum of 24.5 V (ensured by using electronically regulated power supply units).

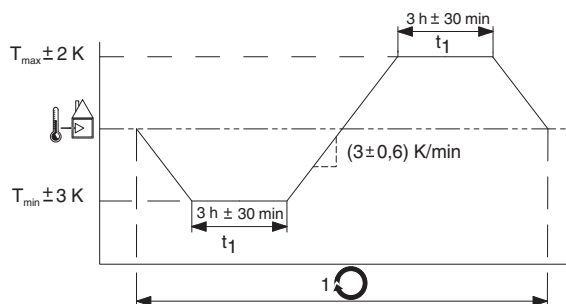

Figure A-2 Temperature change cycle



Temperature in the control cabinet/ambient temperature



Cycle

B Appendix for document lists

B 1 List of figures

Section 3

Figure 3-1:	Components of the controller	16
Figure 3-2:	Axioline F station with AXC 1050 controller	19
Figure 3-3:	PROFINET controller with the AXC 1050 as an example	20
Figure 3-4:	PROFINET device using the AXC 1050 as an example	21
Figure 3-5:	Redundant higher-level control system and lower-level network ring redundancy using MRP	22
Figure 3-6:	Connection and operating elements of the controller (AXC 1050 and AXC 1050 XC)	24
Figure 3-7:	Diagnostics and status indicators	25
Figure 3-8:	Mode selector switch	29
Figure 3-9:	Reset button (1, concealed)	30
Figure 3-10:	Internal basic circuit diagram (AXC 1050 (XC))	32
Figure 3-11:	Communication paths: (1) Ethernet, (2) service interface (Micro-USB type B)	33
Figure 3-12:	Ethernet interface and pin assignment	34
Figure 3-13:	Service interface	35
Figure 3-14:	Terminal points for the supply voltage (communications power U_L)	36
Figure 3-15:	Structure of the bus base module of the controller	36

Section 4

Figure 4-1:	Placing the module vertically	37
Figure 4-2:	Horizontal (A) and vertical (B) mounting position	39
Figure 4-3:	Structure of an Axioline F station with AXC 1050 controller	40
Figure 4-4:	Mounting the bus base modules	41
Figure 4-5:	Snapping on the controller	41
Figure 4-6:	Inserting the SD card	42

Section 5

Figure 5-1:	Overload range with fall-back characteristic curve	43
Figure 5-2:	Overload range without fall-back characteristic curve	43
Figure 5-3:	Connecting a solid cable	44

Figure 5-4:	Connecting a stranded cable	44
Figure 5-5:	Connecting the supply plug	45
Figure 5-6:	Connecting Ethernet	46
Figure 5-7:	Connecting cable between PC and controller	46

Section 6

Figure 6-1:	Selecting the USB driver	47
Figure 6-2:	Project information after creating a new project	48
Figure 6-3:	IP address settings of the controller (AXC 1050)	50
Figure 6-4:	"IP Assignment" dialog: DCP devices are accessible in the network ..	51
Figure 6-5:	"IP Assignment" dialog: assigning an IP address to a DCP device	52
Figure 6-6:	Entering IP address settings	53
Figure 6-7:	"Extras, BootP/SNMP/TFTP-Configuration..." menu	54
Figure 6-8:	"Activate BootP" (A) and "Deactivate BootP" (B) buttons	54
Figure 6-9:	Message window following BootP	55
Figure 6-10:	Successful communication path test	55
Figure 6-11:	Network settings: "Manual definition of the TCP/IP settings"	56
Figure 6-12:	"Settings Communication Path" dialog box	57
Figure 6-13:	IP address settings download successful	57
Figure 6-14:	Activate Network Settings: Restart Controller	57
Figure 6-15:	Activating the network settings: service executed successfully	58
Figure 6-16:	Successful communication path test	58
Figure 6-17:	Network Settings: Activate DHCP	59
Figure 6-18:	"Read Axioline" option	61
Figure 6-19:	"Read Axioline" dialog: Axioline F modules that have not yet been read in	61
Figure 6-20:	Read-in Axioline F devices	62
Figure 6-21:	"Extended Settings, PROFINET activation: PROFINET device activated	63
Figure 6-22:	PROFINET activation: sending settings	64
Figure 6-23:	"Settings Communication Path" dialog	64
Figure 6-24:	PROFINET activation: service successfully executed	64
Figure 6-25:	Activate Network Settings: Restart Controller	65
Figure 6-26:	"Settings Communication Path" dialog	65
Figure 6-27:	Activating the network settings: service executed successfully	65
Figure 6-28:	Bus Structure: PROFINET context menu "Read PROFINET..."	68
Figure 6-29:	"Read PROFINET" dialog	68
Figure 6-30:	"Select PROFINET device description" dialog	69

AXC 1050 (XC)

Figure 6-31:	AXC 1050 (XC) inserted as a PROFINET device	70
Figure 6-32:	AXC 1050 (XC) as a PROFINET device: Process Data	70
Figure 6-33:	Procedure for using the SD card as the main or additional memory	72
Figure 6-34:	Setting the SD card as the main memory	73
Figure 6-35:	Setting the SD card as the additional memory	75
Figure 6-36:	"sddisk" directory on the SD card	76
Figure 6-37:	Newly created "Logfile" directory in the "sddisk" directory	76
Figure 6-38:	Opening the "Logfile.txt" file using the FILE_OPEN function block	77

Section 7

Figure 7-1:	Communication path in Diag+ 2: Start Scan	79
Figure 7-2:	Communication path in Diag+ 2: AXC 1050 (XC) controller found	80
Figure 7-3:	Connection established successfully: selecting the diagnostic view ...	80
Figure 7-4:	Diagnostic view: selecting "Axioline Diagnostic"	81
Figure 7-5:	Diag+ 2: "Axioline Diagnostic"	81
Figure 7-6:	AXL DI 32/1-ME Axioline F module: No error	82
Figure 7-7:	AXL DI 32/1-ME Axioline F module: Supply voltage failure	83
Figure 7-8:	AXC 1050 controller – Peripheral fault	84
Figure 7-9:	Controller context menu	85
Figure 7-10:	Extended Settings: Open FTP Folder on Device	87
Figure 7-11:	Internet Options: Enable FTP folder view	88
Figure 7-12:	Deactivate FTP server	89
Figure 7-13:	Opening the library and selecting the service	91
Figure 7-14:	Defining a user name and password for FTP access	92
Figure 7-15:	Removing the user name and password for FTP access	93
Figure 7-16:	Disabling HTTP	94
Figure 7-17:	Web server: using HTTPS	96
Figure 7-18:	Activate journaling function	98
Figure 7-19:	Activating or deactivating the MRP client function	99
Figure 7-20:	"Insert, Task..." context menu	100
Figure 7-21:	"Insert" dialog	100
Figure 7-22:	"Task settings for 'PowerOf" dialog	101
Figure 7-23:	"PowerOf" event task	101
Figure 7-24:	ETH_SEND function block	104
Figure 7-25:	ETH_RECV function block	106
Figure 7-26:	GET.UTC.TIMESTAMP function block	110
Figure 7-27:	Example programming	113

Figure 7-28:	Alignment: padding bytes in data gaps	113
Figure 7-29:	Example programming with padding bytes	114

Section 9

Figure 9-1:	Changing the language	125
Figure 9-2:	"General Data" page	126
Figure 9-3:	"Technical Data" page	127
Figure 9-4:	"Diagnostic Indicators" page	128
Figure 9-5:	"Controller" page	129
Figure 9-6:	"Local bus" page: overview of the Axioline F local bus devices	130
Figure 9-7:	"Local bus" page: "Module Information" view	131
Figure 9-8:	"Diagnostic Archive" page	132
Figure 9-9:	"Password" page	133
Figure 9-10:	"Factory Defaults" page	135
Figure 9-11:	"Updates via SD card" page	137
Figure 9-12:	"WebVisu" link	138

Section 10

Figure 10-1:	Removing the module so that it is perpendicular to the DIN rail	139
Figure 10-2:	Removing the cable	140
Figure 10-3:	Removing the supply plug	140
Figure 10-4:	Removing the SD card	141
Figure 10-5:	Removing the controller	141

Appendix A

Figure A-1:	Derating for the AXC 1050 XC	152
Figure A-2:	Temperature change cycle	153

B 2 List of tables

Section 3

Table 3-1:	Diagnostics and status indicators of the controller	25
Table 3-2:	Controller operating modes	29
Table 3-3:	Terminal point assignment of the supply connector	36

Section 4

Table 4-1:	Recommended end brackets.....	39
------------	-------------------------------	----

Section 7

Table 7-1:	Function block overview	102
Table 7-2:	Overview of the IP communication blocks.....	103
Table 7-3:	Inputs of the ETH_SEND function block	104
Table 7-4:	Outputs of the ETH_SEND function block	105
Table 7-5:	Inputs/outputs of the ETH_SEND function block.....	105
Table 7-6:	Error codes of the "ADD_ERROR" input/output (ERROR output = TRUE)	105
Table 7-7:	Inputs of the ETH_RECV function block	106
Table 7-8:	Outputs of the ETH_RECV function block.....	107
Table 7-9:	Inputs/outputs of the ETH_RECV function block.....	107
Table 7-10:	Error codes of the "ADD_ERROR" input/output (ERROR output = TRUE)	107
Table 7-11:	Overview of the IP communication blocks.....	109
Table 7-12:	AX_CONTROL function block	109
Table 7-13:	ENABLE input of the GET_UTC_TIMESTAMP function block.....	110
Table 7-14:	Outputs of the GET_UTC_TIMESTAMP function block.....	111

Section 8

Table 8-1:	System variables of the diagnostic status register	115
Table 8-2:	System variables of the diagnostic parameter register.....	116
Table 8-3:	PROFINET system variables (PROFINET controller functionality).....	117
Table 8-4:	PROFINET system variables (PROFINET device function)	118
Table 8-5:	System variables of the IEC-61131 runtime system.....	120
Table 8-6:	System variables of the control processor	121
Table 8-7:	System variable of the control processor for displaying state information	121

List of tables

Table 8-8:	System variables of the Ethernet interfaces	122
Table 8-9:	System variable of the SD card.....	122
Table 8-10:	System variables of the energy storage and real-time clock	122
Table 8-11:	System variables of the power supplies	122
Table 8-12:	System variables of the mode selector switch	123
Table 8-13:	Project-related system variables	123
Table 8-14:	System variables of the system time.....	123

B 3 Index

A

Alignment	112
Applicative system redundancy	22
Areas of application.....	19
Assigning IP address	
BootP server.....	52
Dynamic Host Configuration Protocol (DCP)	59
USB interface	56
Assigning process data	78
Axioline F	
Diagnostics.....	79
Station	40

B

Basic circuit diagram	32
BootP	52, 53
BootP server	52, 142
Bus base module	36

C

Checking the delivery	13
Cold restart	78
Communication paths	33
Micro-USB type B.....	35
Compile.....	71, 78
Connection elements	24
Controller	
Disposal	143
Mounting	41
Removing	141
Creating a project.....	48
Creating the program	78
Creating variables	78

D

DCP	49
Delivery state	30
Derating	152
Device defect	143
Device replacement	142
Diag+	
Controller context menu	85
Diagnostic parameter register	116

Diagnostic status register	115
Diagnostics and status indicators.....	24
Diagnostics indicators	25
DIN rail	38
Discovery and basic Configuration Protocol.....	49
Disposal	143
Controller.....	143
Packaging	143
Dynamic host configuration protocol	59

E

End bracket.....	39
Error diagnostics	25
Ethernet	34
Connection	46
Ethernet interfaces	24, 34
Event task	100
Extreme ambient conditions.....	153

F

Fall-back characteristic curve.....	43
FTP	
Creating, renaming, deleting a directory.....	90
Restricting access	91
FTP functionality	87
FTP server	89

G

General safety notes	9
----------------------------	---

H

Hardware	
Connecting and wiring	43
Mounting	37
Removing	139
Requirements	15
HTTP server.....	94
HTTPS	95
Hypertext Transfer Protocol Secure (HTTPS)	95

I

Intended use	9
--------------------	---

IP address			
Applying immediately	86		
Setting	49		
IP20.....	38		
IP-Adresse zuweisen			
Dynamic Configuration Protocol (DCP)	49		
J			
Journaling function	98		
K			
Kommunikationswege			
Ethernet.....	34		
M			
MAC address	142		
Maintenance	142		
Medienredundanzprotokoll (MRP)	17		
Mode selector switch	24, 29		
Modifications.....	9		
Mounting location.....	38		
Mounting position.....	39		
MRP client function	99		
O			
Operating elements.....	24		
Ordering data	148		
P			
Parameterization memory	31		
Parameterization memory, integrated	31		
Parameterization memory, pluggable.....	31		
Performing updates.....	150		
Ports.....	97		
Power supply			
Connection	44		
Power supply without fall-back characteristic curve ...	43, 145		
PROFINET			
"Read PROFINET" dialog.....	68		
Activating the PROFINET controller/device function ..	63		
PROFINET controller.....	63		
PROFINET device	63		
PROFINET device inserted	70		
PROFINET device process data.....	70		
Read PROFINET	68		
PROFINET controller function.....	63		
PROFINET device function	63		
PROFINET system variables.....	117		
R			
Real-time clock	71		
Removing cables	140		
Removing the plug	140		
Ethernet connector	140		
Supply plug.....	140		
USB plug	140		
Repair	143		
Reset button.....	24, 30		
Resetting the controller.....	30		
Restarting the controller	57, 65		
S			
Safety notes			
General.....	9		
Mounting the hardware.....	37		
Use in potentially explosive areas.....	11		
Scope of supply	14		
SD card			
Additional memory.....	74		
Functions.....	72		
Inserting.....	42		
Main memory.....	72		
Memory for log files	76		
Removing	141		
Sending a project	78		
Sending e-mails	96		
Service interface	35		
Sizing the power supply	43		
Software			
Installing	47		
Requirements	15		
Startup	47		

AXC 1050 (XC)

Status indicators	25
Status information	115
Storage	13
Supply plug	24, 36
System variables.....	115

T

Technical data.....	144
Transport.....	13
Transport damage.....	13

U

Unauthorized network access	10
Unpacking	14
USB cable	
Connection	46
USB driver.....	47

W**WBM**

"Administration" area.....	133
"Diagnostic Archive" page	132
"Diagnostic Indicators" page.....	128
"Diagnostics" area	129
"Factory Defaults" page.....	135
"Firmware Update" page	137
"General Data" page.....	126
"Information" area	126
"Local bus" page	130
"Password" page	133
"Technical Data" page	127
"WebVisu" area	138
Areas and functions.....	125
Changing the language	125
Establishing a connection.....	124
Installing	124
Web server.....	94



SCATTERGOOD & JOHNSON LTD

ELECTRICAL ENGINEERING & FLUID CONTROL DISTRIBUTORS

Est.1899

At Scattergood & Johnson Ltd, we pride ourselves on being a technical distributor to specialist industries.

Working with a range of quality product suppliers across a number of specialist markets, we are not your average 'box shifter' - we are your technical and supply chain partner.

We fully support every product we sell - for free! Our internal team and external sales engineers can answer any product or application question, no matter the complexity.

Backing up this technical ability is a range of 50,000+ products available from stock for nationwide next day delivery (same day if required!), or you can collect what you need from any of our trade counters around the UK.

Select your specialist interest below to learn more about how we can help.

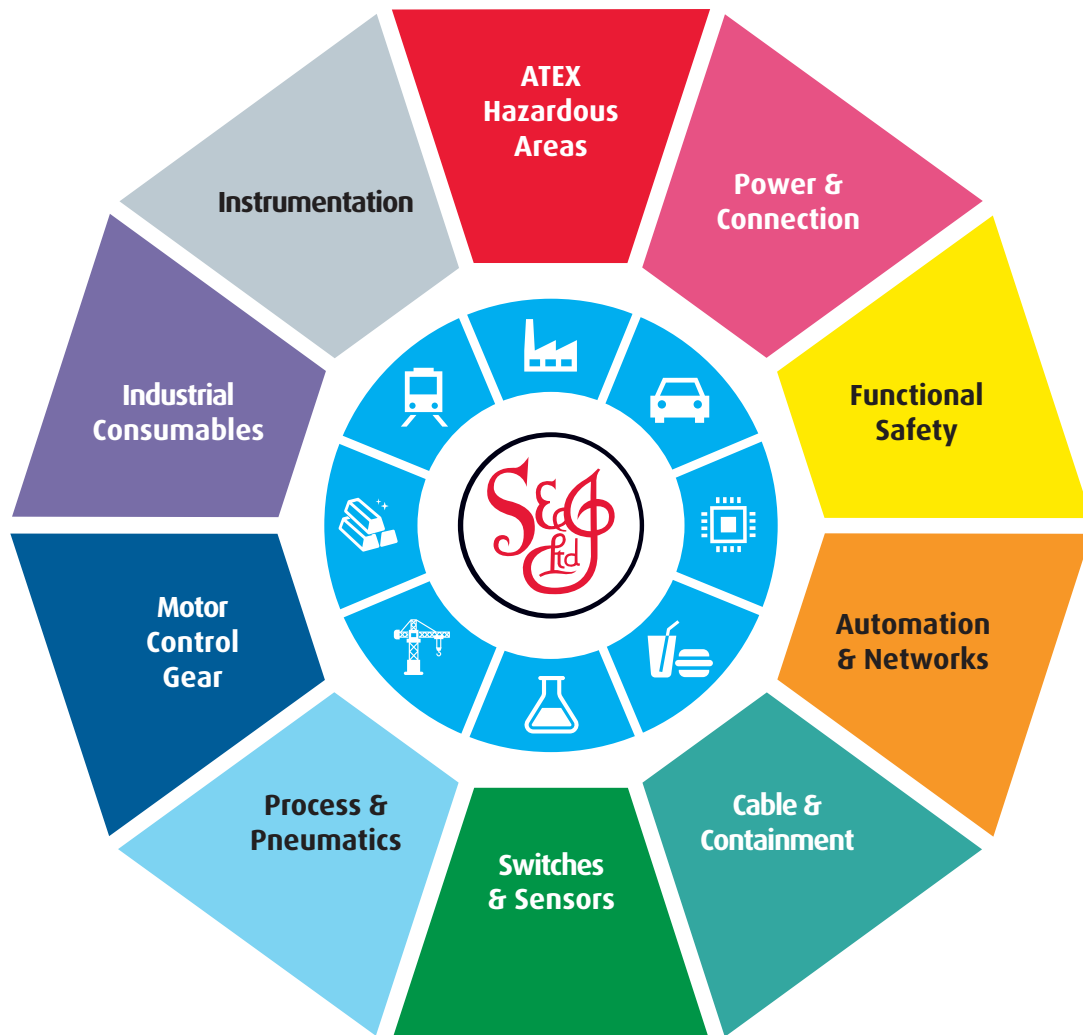

Online, In Branch and On the Road - Scattergood & Johnson Ltd, there when you need us.

www.scatts.co.uk