

AXL E EIP IOL8 DI4 M12 6P

Axioline E EtherNet/IP™ IO-Link device, plastic housing, 8 IO-Link ports, 4 inputs, 24 V DC, M12 fast connection technology



Data sheet
8429_en_11

© PHOENIX CONTACT 2019-09-02

1 Description

The Axioline E device is designed for use within an EtherNet/IP™ network. It enables the operation of up to eight IO-Link sensors/actuators and is also used to acquire digital signals.

EtherNet/IP™ features

- Connection to EtherNet/IP™ network using M12 connectors (D-coded)
- Transmission speed of 10 Mbps and 100 Mbps
- 2 Ethernet ports (with integrated switch)
- Minimum cycle time of 1 ms (RPI)
- Ethernet/IP™ features:
ACD, DLR, IGMP v2, quick connect
- Supported protocols:
SNMP v1, HTTP, TFTP, FTP, BootP, DHCP
- Specification: CIP Edition 3.11;
EIP adaptation of CIP 1.12
- Device description using EDS file
- Firmware can be updated
- Integrated web server for web-based management

IO-Link features

- Connection of eight IO-Link devices
 - 4 IO-Link A ports with additional digital input
 - 4 IO-Link B ports with additional power supply
- Connection of IO-Link ports using M12 connectors (A-coded, 5-pos.)
- Parameterization of devices via CIP objects
- Parameter data storage on the master
- Parameterizable process data width
- IO-Link specification V1.1.2

General features

- Diagnostic and status indicators
- Short-circuit and overload protection of the sensor supply
- IP65/67 degree of protection



This data sheet is only valid in association with the corresponding user manual. Make sure you always use the latest documentation. It can be downloaded via the product at phoenixcontact.net/products.



Only start up the AXL E EtherNet/IP™ devices with the valid EDS file.

2	Table of contents	
1	Description	1
2	Table of contents	2
3	Ordering data	3
4	Technical data	4
5	Internal circuit diagram	9
6	Pin assignment	10
6.1	EtherNet/IP™ and power supply connection	10
6.2	EtherNet/IP™ pin assignment	10
6.3	Pin assignment of the power supply U_S/U_A	10
6.4	Connecting IO Link ports and inputs	11
6.5	Pin assignment of the IO-Link ports and inputs	11
7	Connection example	12
8	Connection notes	12
9	Configuration via rotary encoding switch	13
9.1	Remote access	13
9.2	Manual address assignment	13
9.3	DHCP name assignment	13
9.4	Static address	14
9.5	Resetting IP parameters	14
9.6	Resetting to the default settings	14
9.7	Reserved/invalid switch position	14
10	Local status and diagnostic indicators	15
10.1	Indicators for Ethernet ports and power supply	15
10.2	Displaying the IO-Link ports and inputs	17

3 Ordering data

Description	Type	Order No.	Pcs./Pkt.
Axioline E EtherNet/IP™ IO-Link device in a plastic housing with 8 IO-Link ports and 4 digital inputs, 24 V DC, M12 fast connection technology, degree of protection: IP65/67	AXL E EIP IOL8 DI4 M12 6P	2701496	1
Accessories	Type	Order No.	Pcs./Pkt.
An M12 screw plug for the unoccupied M12 sockets of the sensor/actuator cable, boxes and flush-type connectors (Protection and sealing elements)	PROT-M12	1680539	5
Snap-in markers, Sheet, white, unlabeled, can be labeled with: THERMOMARK PRIME, THERMOMARK CARD, BLUEMARK ID, BLUEMARK ID COLOR, BLUEMARK CLED, TOPMARK NEO, TOPMARK LASER, mounting type: snapped into marker carrier, lettering field size: 7 x 10 mm (Marking)	UCT-EM (7X10)	0830765	10
Documentation	Type	Order No.	Pcs./Pkt.
User manual, English: Axioline E: system and installation	UM EN AXL E SYS INST	-	-
User manual, English: Network-specific properties of the Axioline E EtherNet/IP™ IO-Link devices	UM EN AXL E EIP IOL	-	-
Application note, English: Updating the firmware of Axioline E- devices using the Windows Explorer	AH EN FIRMWARE UPDATE AXL E	-	-
Application note, English: Measures to protect network-capable devices with Ethernet connection against unauthorized access	AH EN INDUSTRIAL SECURITY	-	-
Application note, English: Wiring of Axioline E devices	AH EN AXL E CABLE / WIRING	-	-

Additional ordering data

For additional accessories, visit phoenixcontact.net/products.

4 Technical data

Dimensions (nominal sizes in mm)

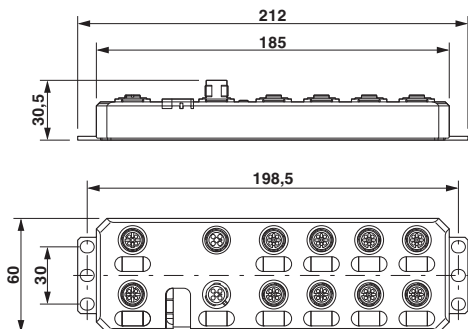

Width	60 mm
Height	185 mm
Depth	30.5 mm
Note on dimensions	The height is 212 mm including fixing clips.

General data

Housing material	Pocan [®]
Color	anthracite
Weight	480 g
Ambient temperature (operation)	-25 °C ... 60 °C



CAUTION: Risk of burns

If the device is used at an ambient temperature above 50°C, the contact temperature of metal surfaces may exceed 70°C.

Ambient temperature (storage/transport)	-25 °C ... 85 °C
Permissible humidity (operation)	5 % ... 95 %
Permissible humidity (storage/transport)	5 % ... 95 %
Air pressure (operation)	70 kPa ... 106 kPa (up to 3000 m above sea level)
Air pressure (storage/transport)	70 kPa ... 106 kPa (up to 3000 m above sea level)
Degree of protection	IP65/67
Protection class	III, IEC 61140, EN 61140, VDE 0140-1

Connection data

Connection method	M12 connector
-------------------	---------------

Interface EtherNet/IP™

Number	2
Designation connection point	Copper cable
Connection method	M12 fast connection technology
Note on connection method	D-coded
Number of positions	4
Transmission speed	10/100 Mbps (with autonegotiation)
Cycle Time	min. 1 ms (RPI)

EtherNet/IP™

Equipment type	EtherNet/IP™ slave
EtherNet/IP™ protocols	ACD, DLR, IGMP v2
Additional protocols	SNMP v1, HTTP, TFTP, FTP, BootP, DHCP
Specification	CIP Edition 3.11 EIP adaptation of CIP 1.12

Supply: Module electronics and sensors (U_S)

Connection method	M12 connector (T-coded)
Number of positions	4
Supply voltage	24 V DC
Nominal supply voltage range	19.5 V DC ... 31.2 V DC (including all tolerances, including ripple)
Current consumption	typ. 180 mA ±15 % (at 24 V DC) max. 12 A

Supply: Actuators (U_A)

Connection method	M12 connector (T-coded)
Number of positions	4
Supply voltage	24 V DC
Nominal supply voltage range	18 V DC ... 31.2 V DC (including all tolerances, including ripple)
Current consumption	typ. 28 mA ±15 % (at 24 V DC) max. 12 A

IO-Link ports: Class A

Number of ports	4
Connection method	M12 fast connection technology
Connection method	3-wire
MasterCycleTime	min. 2 ms (PDInput* + PDOOutput* + OnReqData* ≤ 17 Byte; COM3)) * see "IO-Link Interface and System Specification V1.1.2"

IO-Link ports: Class B

Number of ports	4
-----------------	---

IO-Link ports: Class B	
Connection method	M12 fast connection technology
Connection method	3-wire
MasterCycleTime	min. 2 ms (PDInput* + PDOOutput* + OnReqData* ≤ 17 Byte; COM3) * see "IO-Link Interface and System Specification V1.1.2"

IO-Link port supply	
Nominal voltage for I/O supply	24 V DC
Nominal current for every IO-Link port	150 mA at C/Q (pin 4), maximum of 1.6 A over all 8 IO-Link C/Q and L+ cables 200 mA at L+/L- (pin 1 and pin 3), during startup, up to 1.6 A for short periods max. 2 A at U _A (IO-Link B ports, pin 2 and pin 5)
Overload protection	yes
Permissible conductor length to the sensor	< 20 m

IO-Link ports in digital input (DI) mode	
Number of inputs	max. 8 (EN 61131-2 type 1)
Connection method	M12 connector, X01 ... X04 have double occupancy
Connection method	3-wire
Nominal input voltage	24 V DC
Nominal input current	typ. 3 mA
Sensor current per channel	max. 200 mA (from L+/L-)
Total sensor current	max. 1.6 A (from L+/L-)
Input voltage range "0" signal	-0.3 V DC ... 5 V DC
Input voltage range "1" signal	15 V DC ... 30 V DC
Input filter time	< 1000 μs
Input frequency	0.5 kHz
Overload protection	yes
Short-circuit protection for the sensor supply	yes

IO-Link ports in digital output (DO) mode	
Number of outputs	max. 8
Connection method	M12 connector, X01 ... X04 have double occupancy
Connection method	3-wire
Nominal output voltage	24 V DC
Maximum output current per channel	150 mA
Maximum output current per module	1.2 A
Nominal load, ohmic	3.6 W (160 Ω, at nominal load)
Nominal load, inductive	3.6 VA (0.8 H, 160 Ω, at nominal load)
Signal delay	max. 150 μs (when switched on) max. 200 μs (when switched off)
Switching rate	1 per second, maximum (at nominal inductive load) 5500 per second, maximum (at nominal ohmic load)
Limitation of the voltage induced on circuit interruption	-15 V DC

IO-Link ports in digital output (DO) mode

Output voltage when switched off	max. 1 V
Output current when switched off	max. 300 μ A
Behavior with overload	Shutdown with automatic restart
Overload protection	yes
Short-circuit protection	yes

Digital inputs at pin 2 for type A ports

Number of inputs	4 (EN 61131-2 type 1)
Connection method	M12 connector, X01 ... X04 have double occupancy
Connection method	3-wire
Nominal input voltage	24 V DC
Nominal input current	typ. 3 mA
Sensor current per channel	max. 200 mA (from L+/L-)
Total sensor current	max. 1.6 A (from L+/L-)
Input voltage range "0" signal	-0.3 V DC ... 5 V DC
Input voltage range "1" signal	15 V DC ... 30 V DC
Input filter time	< 1000 μ s
Input frequency	0.5 kHz
Overload protection	yes
Short-circuit protection for the sensor supply	yes

Electrical isolation/isolation of the voltage areas

Test section	Test voltage
24 V supply (communications power and sensor supply, IO-Link ports)/bus connection (Ethernet 1)	500 V AC, 50 Hz, 1 min.
24 V supply (communications power and sensor supply, IO-Link ports)/bus connection (Ethernet 2)	500 V AC, 50 Hz, 1 min.
24 V supply (communications power and sensor supply, IO-Link ports)/FE	500 V AC, 50 Hz, 1 min.
Bus connection (Ethernet 1)/FE	500 V AC, 50 Hz, 1 min.
Bus connection (Ethernet 2)/FE	500 V AC, 50 Hz, 1 min.
Bus connection (Ethernet 1)/bus connection (Ethernet 2)	500 V AC, 50 Hz, 1 min.
24 V supply (actuator supply)/24 V supply (communications power and sensor supply, IO-Link ports)	500 V AC, 50 Hz, 1 min.
24 V supply (actuator supply)/bus connection (Ethernet 1)	500 V AC, 50 Hz, 1 min.
24 V supply (actuator supply)/bus connection (Ethernet 2)	500 V AC, 50 Hz, 1 min.
24 V supply (actuator supply)/FE	500 V AC, 50 Hz, 1 min.

Mechanical tests

Vibration resistance according to EN 60068-2-6/IEC 60068-2-6	5g
Shock according to EN 60068-2-27/IEC 60068-2-27	30g, 11 ms period, half-sine shock pulse
Continuous shock according to EN 60068-2-27/IEC 60068-2-27	10g

Conformance with EMC Directive 2014/30/EU**Noise immunity test in accordance with EN 61000-6-2**

Electrostatic discharge (ESD) EN 61000-4-2/IEC 61000-4-2	Criterion B, 6 kV contact discharge, 8 kV air discharge
--	---

Electromagnetic fields EN 61000-4-3/IEC 61000-4-3	Criterion A, Field intensity: 10 V/m
---	--------------------------------------

Fast transients (burst) EN 61000-4-4/IEC 61000-4-4	Criterion B, 2 kV
--	-------------------

Transient overvoltage (surge) EN 61000-4-5/IEC 61000-4-5	Criterion B, DC supply lines: ± 0.5 kV/ ± 0.5 kV (symmetrical/asymmetrical)
--	---

Conducted interference EN 61000-4-6/IEC 61000-4-6	Criterion A; Test voltage 10 V
---	--------------------------------

Noise emission test as per EN 61000-6-4	Class A
--	---------

Approvals

For the latest approvals, please visit phoenixcontact.net/products.

5 Internal circuit diagram

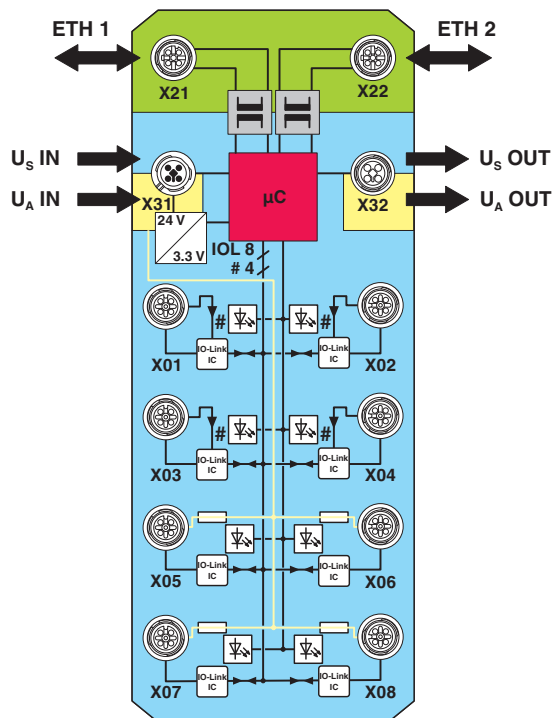

Key:







- Green area: Network
- Blue area: U_S
- Yellow area: U_A
-  Transmitter with electrical isolation
-  Power supply unit with electrical isolation
-  Microcontroller
-  Digital input
-  IO-Link IC
-  LED
-  Fuse

Figure 1 Internal wiring of connections

6 Pin assignment

6.1 EtherNet/IP™ and power supply connection

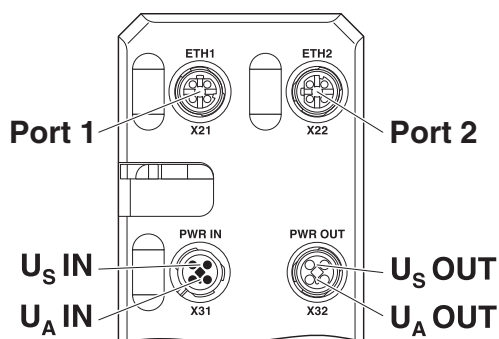

Figure 2 Connections for EtherNet/IP™ and voltage supply

Designation	Meaning
Port 1 (X21)	Ethernet port 1
Port 2 (X22)	Ethernet port 2
U _S IN (X31)	Power supply IN (logic and sensors)
U _A IN (X31)	Power supply IN (actuators)
U _S OUT (X32)	Power supply OUT for additional devices
U _A OUT (X32)	Power supply OUT for additional devices



Ground the device by means of the mounting screws.

6.2 EtherNet/IP™ pin assignment

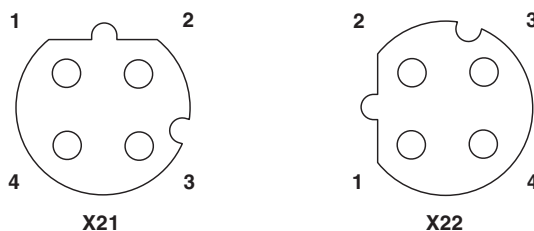

Figure 3 Ethernet pin assignment, D-coded

Pin	Ethernet port 1 (X21)	Ethernet port 2 (X22)
1	TX+	TX+
2	RX+	RX+
3	TX-	TX-
4	RX-	RX-



The shield is connected to FE in the device.



The thread is used for additional shielding.

6.3 Pin assignment of the power supply U_S/U_A

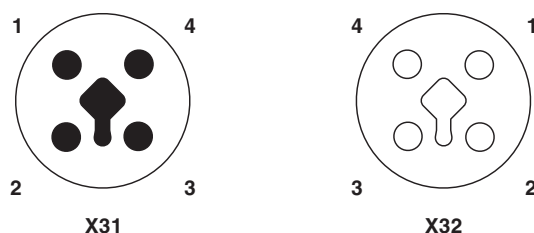

Figure 4 Pin assignment of the power supply, T-coded

Pin	IN	OUT	Conductor colors
1	+24 V DC (U _S)	+24 V DC (U _S)	Brown
2	GND (U _A)	GND (U _A)	White
3	GND (U _S)	GND (U _S)	Blue
4	+24 V DC (U _A)	+24 V DC (U _A)	Black



Make sure that the power supply U_A and the power supply U_S of two independent connected, electrically isolated power supplies takes place.

6.4 Connecting IO Link ports and inputs

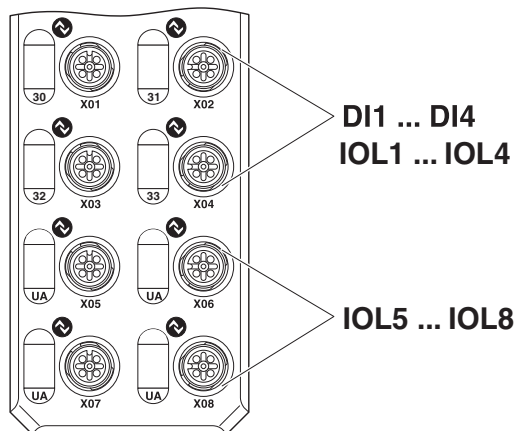

Figure 5 IO-Link port and digital input connections

Designation	Meaning
DI1 ... DI4 (X01 ... X04)	Inputs 1 ... 4 (pin 2)
IOL1 ... 4 (X01 ... X04)	IO-Link A ports 1 ... 4
IOL 5 ... 8 (X05 ... X08)	IO-Link B ports 5 ... 8



IO-Link A port

The IO-Link A port is assigned an additional hardwired DI (digital input) at pin 2.

IO-Link B port

The IO-Link B port has an additional supply voltage via pin 2 and pin 5. This port is suitable for connecting devices that have a higher current consumption. There are max. 2 A nominal current provided.

Operating modes

The C/Q cable (pin 4) can be configured independently of the other pins.

The IO-Link ports can be operated in the following operating modes:

- DI (behaves like a digital input)
- DO (behaves like a digital output)
- DI with IO-Link
- IO-Link

6.5 Pin assignment of the IO-Link ports and inputs

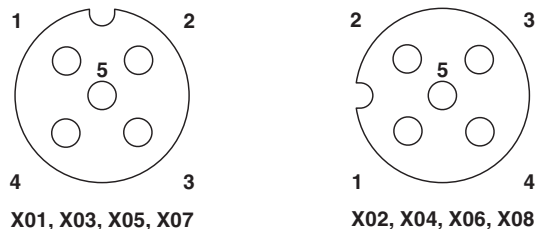

Figure 6 IO-Link ports pin assignment, A-coded

Pin	IO-Link A ports (X01 ... X04)	IO-Link B ports (X05 ... X08)
1	24 V DC (L+)	24 V DC (L+)
2	DI	24 V DC (U _A)
3	GND (L-)	GND (L-)
4	C/Q, I/O link data transmission cable	C/Q, I/O link data transmission cable
5	Not used	GND (U _A)



NOTE: Sensor damage

When connecting an IO-type A sensor to an IO-Link B port that a voltage is applied to pin 2 and pin 5. Do not connect it to the sensor. Use a three-conductor cable between port and sensor, e.g., cable type SAC-3P-M12MS/.../... Order No. 1696662.



Nominal current at L+/L-

Pin 1 and pin 3 provide a nominal current of 200 mA, maximum. Higher currents are briefly permitted during startup. The current is then limited electronically.

7 Connection example

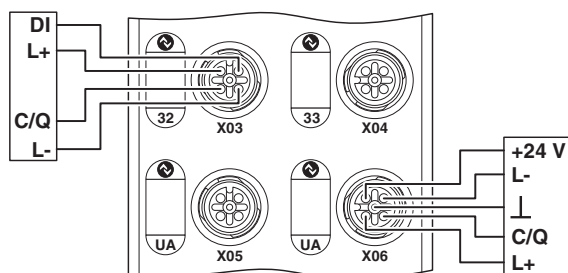

Figure 7 Typical connection of IO Link devices (A ports, X03) and (B ports, X06)

8 Connection notes



NOTE: Data corruption or loss

Implement the FE connection using mounting screws, in order to ensure immunity to interference.



NOTE: Device damage

To ensure IP65/67 degree of protection, cover unused sockets with protective caps.



NOTE: Damage to the electronics

Only supply the IO-Link master and the IO-Link devices with the voltage U_S and U_A provided at the terminal points.



NOTE: Damage to the electronics

Observe the correct polarity of the supply voltages U_S and U_A in order to prevent damage to the device.



NOTE: Malfunction

When connecting the sensors and actuators, observe the assignment of the connections to the EtherNet/IP™ input and output data.



Secure the device to a level surface or to a profile. Do not use this device to bridge gaps, in order to prevent forces being transmitted via the device.



Use standard M5 screws with toothed lock washer and self-locking nuts. Observe the maximum torque of the screws.

9 Configuration via rotary encoding switch

You can configure the address assignment and other functions using rotary encoding switches.

After modifying the switch position, restart the device, as the modification to the switch position does not take effect during operation.

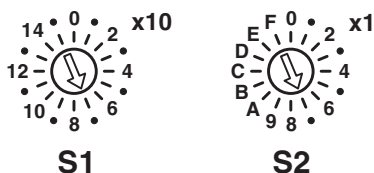

Figure 8 Rotary encoding switch

The code results from the sum of S1 x 10 plus S2 x 1.
The image shows code 77 (7 x 10 + 7).

S1	S2	Code	Function
0	0	00	Remote access (default)
0 ... 5	1 ... 0	01 ... 50	Manual address assignment
5 ... 15	0 ... 9	51 ... 159	DHCP name assignment
0	A	0A	Static address
0	E	0E	Resetting IP parameters
0	F	0F	Resetting to the default settings
Other			Reserved

9.1 Remote access

Switch position 00

At this switch position, it is possible to remotely configure the device using corresponding tools (e.g., Startup+, web-based management (WBM)).

Behavior during initial startup, after resetting the IP parameters or after resetting to default settings

A valid IP address is not assigned (0.0.0.0) and communication is therefore not possible.

The device transmits continuous BootP requests, until a valid IP address has been received.

0 s, 4 s, 8 s, 16 s, 32 s, 5 s, 4 s, 8 s, 16 s, 32 s, 5 s, 4 s ...

Valid IP parameters are then automatically saved as configuration data on the device.

Each additional startup

If BootP is not explicitly deactivated, the device transmits continuous BootP requests, until a valid IP address has been received.

0 s, 4 s, 8 s, 16 s, 32 s, 5 s, 4 s, 8 s, 16 s, 32 s, 5 s, 4 s ...

Valid IP parameters are then automatically saved as configuration data on the device.

9.2 Manual address assignment

Switch position 01 ... 50

Default: BootP deactivated, DHCP activated

The first three octets in the IP address are preset as 192.168.0.x.

The subnet mask is 255.255.255.0.

Specify the last byte with the switch position.

As such, you can select IP addresses between 192.168.0.1 and 192.168.0.50.

Prior to transferring the IP address, a test is performed to check for any potential IP address conflicts. If a conflict is detected, the device temporarily switches the IP address to 0.0.0.0 (no IP communication). In this case, the NET LED flashes red. Eliminate the conflict and restart the device.

9.3 DHCP name assignment

Switch position 51 ... 159

This switch position is used to easily specify the DHCP host name for the device.

The host name is provided to the DHCP server via DHCP options. This is therefore able to send a DNS update to the DNS server.

The DNS name consists of one set part, which is based on the order designation, and a variable part, which is determined by the switch position.

The first part of the station name is AXL-BK-EIP-.

The set number is added.

This results in the following station names: AXL-BK-EIP-51 ... AXL-BK-EIP-159.

Behavior during initial startup, after resetting the IP parameters or after resetting to default settings

A valid IP address is not assigned (0.0.0.0) and communication is therefore not possible.

The device transmits continuous DHCP discover messages until a valid IP address has been received.

Each additional startup

The device transmits continuous DHCP requests.

There are two possible scenarios:

1. The DHCP server assigns a new IP address.
⇒ The device applies the new IP parameters.
2. The DHCP server does not respond.
⇒ The device transmits continuous DHCP Discover messages until new IP parameters have been received.

9.4 Static address**Switch position 0A****Behavior during initial startup, after resetting the IP parameters or after resetting to default settings**

A valid IP address is not assigned (0.0.0.0) and communication is therefore not possible.

Assign an address initially with another switch position.

Each additional startup

After a voltage reset, the device maintains the IP address which was assigned last.



With this switch position, modifying the IP address via tools or web-based management is not possible.

9.5 Resetting IP parameters**Switch position 0E**

The IP parameters stored on the device are reset.

All other settings made on the device are retained.

- BootP is activated for switch position 00.
- IP address, subnet mask: 0.0.0.0

As long as the switch position 0E remains selected, no connection to the device can be established.

IP communication is deactivated (LED NET static yellow).

9.6 Resetting to the default settings**Switch position 0F**

All settings are reset to default settings, including IP parameters.



The device is ready for operation after powering up, as soon as the RDY LED lights up green.
A connection to the device however cannot be established in this switch position.
As soon as the RDY LED lights up green, a new switch position can be selected on the rotary encoding switch and the device can be restarted.

9.7 Reserved/invalid switch position

The device starts with the previous settings, e.g., with the settings that were valid before the device was restarted.

An invalid switch position is indicated by the RDY LED (red on).

10 Local status and diagnostic indicators

10.1 Indicators for Ethernet ports and power supply

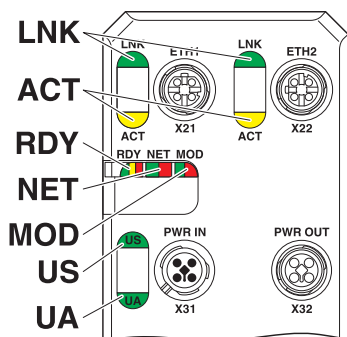

Figure 9 Indicators for Ethernet ports and power supply

Designation	Color	Meaning	State	Description
LNK 1/2	Green	Link	Green on	Connection is present at port 1/2.
			Off	Connection is not present at port 1/2.
ACT 1/2	Yellow	Activity	Yellow flashing	Data transmission is present at port 1/2.
			Off	Data transmission is not present at port 1/2.
RDY	Green/ yellow/ red	Ready	Green On	Device is ready for operation.
			Yellow flashing	Firmware update is being performed.
			Flashing green/ yellow	Over- or undervoltage at U_S
				Temperature of the device is in the critical area.
				Failure of the actuator supply U_A And red US LED: sensor supply overload
			Red on	Rotary encoding switches are set to an invalid/reserved position.
Off	Device is not ready for operation.			
NET	Green/ red	Network status	Green on	At least one CIP connection is in place and the exclusive owner connection has no timeout.
			Green flashing	An IP address is configured, no CIP connection is yet in place, and the exclusive owner connection has no timeout.
			Red on	An IP address conflict has been determined.
			Flashing red	Connection timeout. A timeout of an exclusive owner connection has occurred.
			Flashing green/ red	Self test
			Off	Device is not ready for operation.

AXL E EIP IOL8 DI4 M12 6P

Designation	Color	Meaning	State	Description
MOD	Green/ red	Module status	Green on	Normal operation
			Green flashing	The device is not configured.
			Red on	A unrecoverable error has occurred.
			Flashing red	A recoverable error has occurred.
			Flashing green/ red	Self test
			Off	Device is not ready for operation.
US	Green/ red	U_{sensors}	Green on	Communications power/sensor voltage present
			Off	Communications power/sensor voltage not present or too low.
			Red on	Sensor voltage overload
UA	Green	U_{actuators}	On	Actuator voltage is present.
			Off	Actuator voltage is not present.

10.2 Displaying the IO-Link ports and inputs

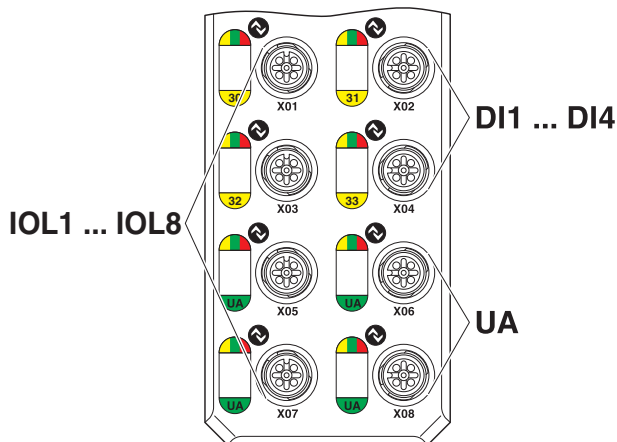

Figure 10 Displaying the IO-Link port and inputs

Designation	Color	Meaning	State	Description
IO-Link LED	Green/ yellow/ red	Status of the IO-Link ports (X01 ... X08)	Green on	In IO-Link mode: IO-Link communication present.
			Green flashing	In IO-Link mode: no IO-Link communication.
			Yellow on	The digital input or output is set in DI or DO mode.
			Red on	In IO-Link mode: IO-Link communication error
			Red on	In IO-Link mode: overload of the L+/L- cable
			Red on	In DI or DO mode: overload of the L+/L- cable
			Red on	Overload of the C/Q cable
			Off	The digital input or output is not set in DI or DO mode.
30 ... 33	Yellow	Status of the digital inputs	On	Input is set.
			Off	Input is not set.
UA	Green/ red	Actuator supply for X05 ... X08	Green On	Actuator voltage is present.
			Off	Actuator voltage is not present.
			Red on	Short circuit between pin 2 and pin 5



The numbering of the LEDs is as follows: the first number specifies the byte, the second number specifies the bit.



SCATTERGOOD & JOHNSON LTD

ELECTRICAL ENGINEERING & FLUID CONTROL DISTRIBUTORS

Est.1899

At Scattergood & Johnson Ltd, we pride ourselves on being a technical distributor to specialist industries.

Working with a range of quality product suppliers across a number of specialist markets, we are not your average 'box shifter' - we are your technical and supply chain partner.

We fully support every product we sell - for free! Our internal team and external sales engineers can answer any product or application question, no matter the complexity.

Backing up this technical ability is a range of 50,000+ products available from stock for nationwide next day delivery (same day if required!), or you can collect what you need from any of our trade counters around the UK.

Select your specialist interest below to learn more about how we can help.

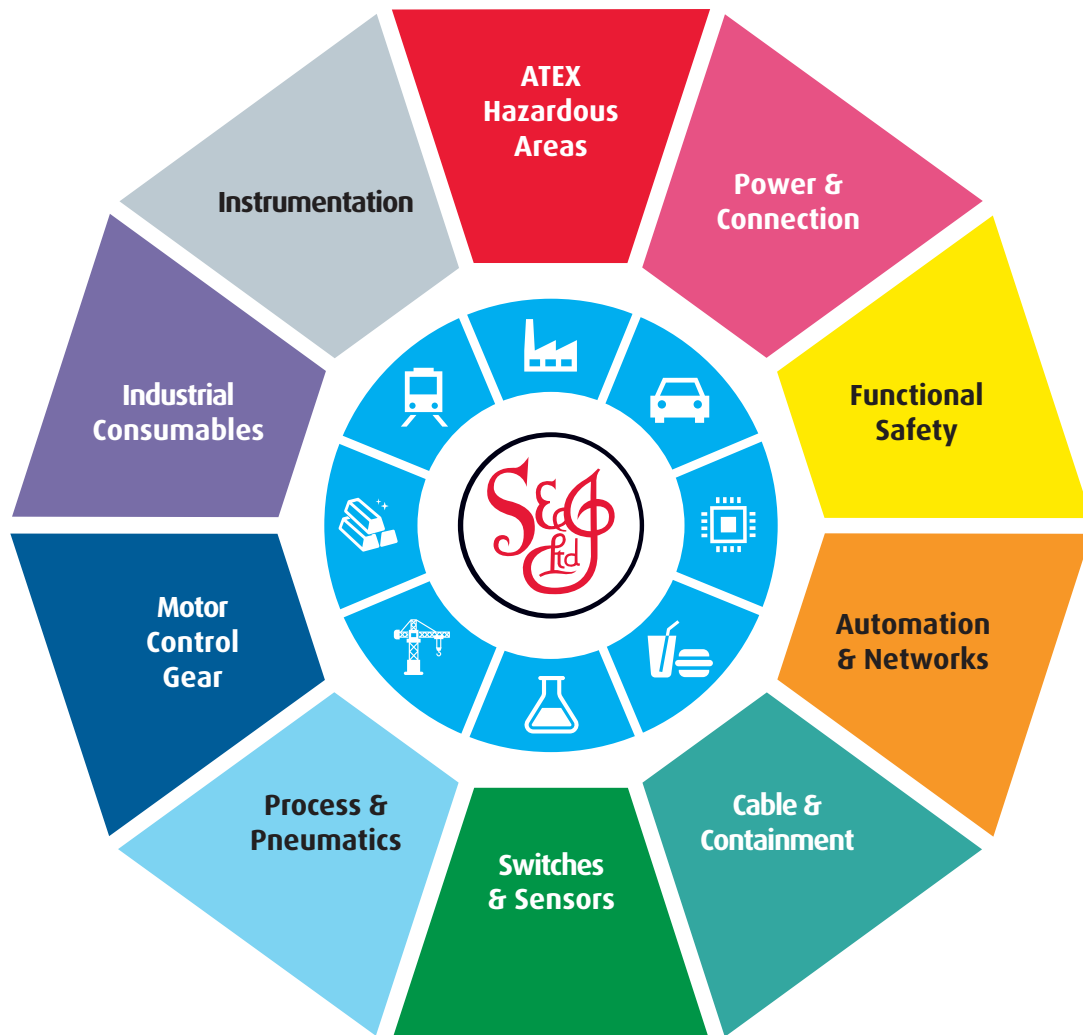

Online, In Branch and On the Road - Scattergood & Johnson Ltd, there when you need us.

www.scatts.co.uk