

AXL E PB DIO16 M12 6M

**Axioline E PROFIBUS device, metal housing,
16 freely configurable inputs or outputs,
24 V DC, M12 fast connection technology**



Data sheet
8432_en_06

© PHOENIX CONTACT 2019-02-27

1 Description

The Axioline E device is designed for use within a PROFIBUS network. It is used to acquire and output digital signals.

The device is designed for use in systems manufacturing. It is suitable for use without a control cabinet under harsh industrial conditions. The Axioline E device can be used on tool platforms, directly on welding robots or in conveying technology, for example.

PROFIBUS features

- Connection to PROFIBUS DP using M12 connectors (B-coded)
- DP/V1 for Class 1 and Class 2 masters
- Data transmission speed of 9.6 kbps up to 12 Mbps (automatic detection)
- Rotary encoding switches for setting the PROFIBUS address
- Supported PROFIBUS addresses 0 to 126
- PROFIBUS features: Sync mode, Freeze mode, I & M functions
- Device description using GSD file

Axioline E features

- Connection of digital sensors and actuators to M12 connectors (A-coded)
- Diagnostic and status indicators
- Short-circuit and overload protection of the sensor supply
- IP65/67 degree of protection



This data sheet is only valid in association with the associated user manual. Make sure you always use the latest documentation. It can be downloaded from the product at phoenixcontact.net/products.

2	Table of contents	
1	Description	1
2	Table of contents	2
3	Ordering data	3
4	Technical data	4
5	Internal circuit diagram	8
6	Pin assignment	9
	6.1 PROFIBUS and power supply connection	9
	6.2 PROFIBUS pin assignment	9
	6.3 Pin assignment of the power supply U_S/U_A	10
	6.4 Connecting inputs and outputs	10
	6.5 Pin assignment of the inputs and outputs	10
7	Connection example	11
8	Connection notes	11
9	Configuration via rotary encoding switch	12
10	Local status and diagnostic indicators	13
	10.1 Indicators for bus and power supply	13
	10.2 Input and output indicators	14
11	Process data	15
	11.1 Assignment of the terminal points to the IN process data	15
	11.2 Assignment of the terminal points to the OUT process data	15
	11.3 Status module	15
	11.4 Configuration of digital inputs and outputs	15
12	Parameterization	16
13	I&M functions	17
14	Sync/freeze mode	18
15	Diagnostic alarms	18
16	Monitoring	18
17	Substitute value behavior	18

3 Ordering data

Description	Type	Order No.	Pcs./Pkt.
Axioline E PROFIBUS device in a metal housing with 16 configurable inputs or outputs, 24 V DC, M12 fast connection technology, degree of protection: IP65/67	AXL E PB DIO16 M12 6M	2701506	1
Accessories			
An M12 screw plug for the unoccupied M12 sockets of the sensor/actuator cable, boxes and flush-type connectors (Protection and sealing elements)	PROT-M12	1680539	5
Terminating resistor PROFIBUS M12 (Connector/Adapter)	SAC-5P-M12MS PB TR	1507803	5
Mounting plate for Axioline E metal devices (Assembly)	AXL E MP 60	2701761	1
Snap-in markers, Sheet, white, unlabeled, can be labeled with: THERMOMARK PRIME, THERMOMARK CARD, BLUEMARK ID, BLUEMARK ID COLOR, BLUEMARK CLED, TOPMARK NEO, TOPMARK LASER, mounting type: snapped into marker carrier, lettering field size: 7 x 10 mm (Marking)	UCT-EM (7X10)	0830765	10
Documentation			
User manual, English: Axioline E: system and installation	UM EN AXL E SYS INST	-	-
Application note, English: Startup of Axioline E PROFIBUS devices on a SIMATIC® S7 controller (for experienced S7 users)	AH EN S7 - AXL E PB PRO	-	-
Application note, English: Wiring of Axioline E devices	AH EN AXL E CABLE / WIRING	-	-

Additional ordering data

For additional accessories, visit phoenixcontact.net/products.

4 Technical data

Dimensions (nominal sizes in mm)

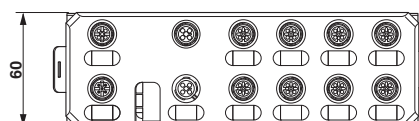
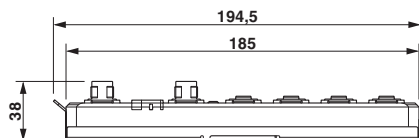

Width	60 mm
Height	185 mm
Depth	38 mm
Note on dimensions	The height is 194.5 mm including the mounting plate. With fixing clips pulled out, the height is 212 mm. The depth is 38 mm including the mounting plate (30.5 mm without the mounting plate).

General data

Housing material	Zinc die-cast
Weight	750 g
Ambient temperature (operation)	-25 °C ... 60 °C



CAUTION: Risk of burns

If the device is used at an ambient temperature above 50°C, the contact temperature of metal surfaces may exceed 70°C.

Ambient temperature (storage/transport)	-25 °C ... 85 °C
Permissible humidity (operation)	5 % ... 95 %
Permissible humidity (storage/transport)	5 % ... 95 %
Air pressure (operation)	70 kPa ... 106 kPa (up to 3000 m above sea level)
Air pressure (storage/transport)	70 kPa ... 106 kPa (up to 3000 m above sea level)
Degree of protection	IP65/67
Protection class	III, IEC 61140, EN 61140, VDE 0140-1

Connection data

Connection method	M12 connector
-------------------	---------------

Interface PROFIBUS DP

Number	2
Connection method	2x M12 connectors, B-coded
Designation connection point	Copper cable
Number of positions	5
Transmission speed	9,6 kBit/s ... 12 MBit/s (Automatic baud rate detection)
Transmission physics	PROFIBUS-DP-compliant copper cable

PROFIBUS DP

Equipment type	PROFIBUS slave
PROFIBUS protocols	DP V1

Supply: Module electronics, sensors and actuators (U_S)

Connection method	M12 connector (T-coded)
Number of positions	4
Supply voltage	24 V DC
Nominal supply voltage range	18 V DC ... 31.2 V DC (including all tolerances, including ripple)
Current consumption	typ. 165 mA ±15 % (at 24 V DC) max. 12 A

Supply: Actuators (U_A) for additional devices

Connection method	M12 connector (T-coded)
Number of positions	4
Supply voltage	24 V DC
Nominal supply voltage range	18 V DC ... 31.2 V DC (including all tolerances, including ripple)
Current consumption	typ. 3 mA ±15 % (at 24 V DC) max. 12 A

Digital inputs

Number of inputs	16 (EN 61131-2 types 1 and 3)
Connection method	M12 connector, double occupancy
Connection method	4-wire
Nominal input voltage	24 V DC
Nominal input current	typ. 3 mA
Sensor current per channel	typ. 75 mA (from U _S)
Total sensor current	max. 1.2 A (per device)
Input voltage range "0" signal	0 V DC ... 5 V DC
Input voltage range "1" signal	11 V DC ... 30 V DC
Input filter time	< 1000 μs
Permissible conductor length to the sensor	30 m
Overload protection, short-circuit protection of sensor supply	yes

Digital outputs	
Number of outputs	16
Connection method	M12 connector, double occupancy
Connection method	3-wire
Nominal output voltage	24 V DC (from voltage U_S)
Output voltage range	18 V DC ... 31.2 V DC
Maximum output current per channel	0.5 A
Nominal load, ohmic	12 W (48 Ω ; with nominal voltage)
Nominal load, inductive	12 VA (1.2 H; 48 Ω ; with nominal voltage)
Signal delay	max. 150 μ s (when switched on) max. 200 μ s (when switched off)
Switching frequency	max. 5500 per second (with at least 50 mA load current)
Switching frequency	max. 1 per second (with inductive load)
Limitation of the voltage induced on circuit interruption	-28 V ... -17 V
Output voltage when switched off	max. 1 V
Output current when switched off	max. 20 μ A
Behavior with overload	Auto restart
Reverse voltage resistance to short pulses	Reverse voltage proof
Overcurrent shut-down	min. 0.7 A
Overload protection, short-circuit protection of outputs	yes

Configuration data	
ID number	0E5A
Input address area	16 Bit
Output address area	16 Bit

Electrical isolation/isolation of the voltage areas	
Test section	Test voltage
24 V supply (communications power and sensor supply, digital inputs/outputs)/bus connection	500 V AC, 50 Hz, 1 min
24 V supply (communications power and sensor supply, digital inputs/outputs)/FE	500 V AC, 50 Hz, 1 min
Bus connection / FE	500 V AC, 50 Hz, 1 min
24 V supply (actuator supply)/24 V supply (communications power and sensor supply, digital inputs/outputs)	500 V AC, 50 Hz, 1 min
24 V supply (actuator supply)/bus connection	500 V AC, 50 Hz, 1 min
24 V supply (actuator supply)/FE	500 V AC, 50 Hz, 1 min

Mechanical tests

Vibration resistance according to EN 60068-2-6/IEC 60068-2-6	5g
Shock according to EN 60068-2-27/IEC 60068-2-27	30g, 11 ms period, half-sine shock pulse
Continuous shock according to EN 60068-2-27/IEC 60068-2-27	10g

Conformance with EMC Directive 2004/108/EC**Noise immunity test in accordance with EN 61000-6-2**

Electrostatic discharge (ESD) EN 61000-4-2/IEC 61000-4-2	Criterion B; 6 kV contact discharge, 8 kV air discharge
Electromagnetic fields EN 61000-4-3/IEC 61000-4-3	Criterion A; Field intensity: 10 V/m
Fast transients (burst) EN 61000-4-4/IEC 61000-4-4	Criterion B, 2 kV
Transient surge voltage (surge) EN 61000-4-5/IEC 61000-4-5	Criterion B; DC supply lines: ± 0.5 kV/ ± 0.5 kV (symmetrical/asymmetrical)
Conducted interference EN 61000-4-6/IEC 61000-4-6	Criterion A; Test voltage 10 V
Noise emission test as per EN 61000-6-4	Class A

Approvals

For the latest approvals, please visit phoenixcontact.net/products

5 Internal circuit diagram

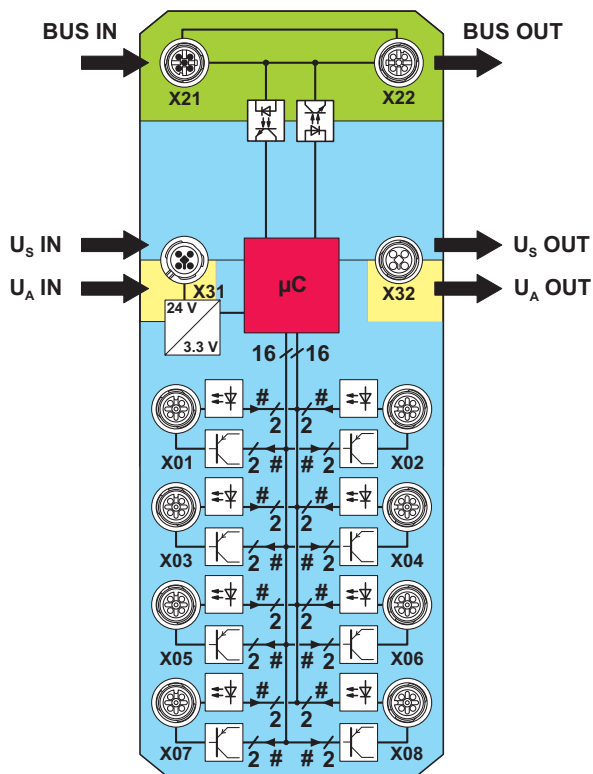
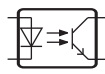







Figure 1 Internal wiring of connections

Key:

Green area: Network
 Blue area: U_S
 Yellow area: U_A

-  Optocoupler
-  Power supply unit with electrical isolation
-  Microcontroller
-  Digital input
-  Digital output
-  LED
-  Transistor

i The device and the freely configurable inputs and outputs are supplied from the voltage U_S . The voltage U_A is only passed through the device. Separate switching-off of the outputs is therefore not possible.

6 Pin assignment

6.1 PROFIBUS and power supply connection

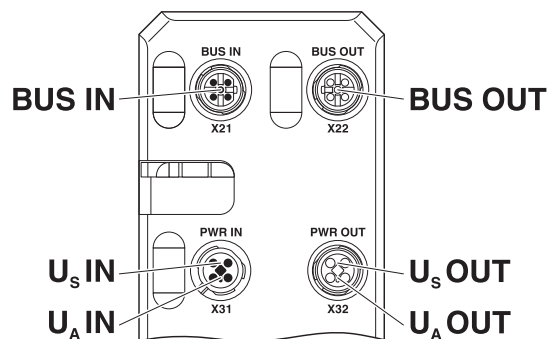

Figure 2 Connections for PROFIBUS and power supply

Designation	Meaning
BUS IN (X21)	PROFIBUS IN
BUS OUT (X22)	PROFIBUS OUT
U _S IN (X31)	Power supply IN (logic, sensors and actuators)
U _A IN (X31)	Power Supply IN (actuators) for additional devices
U _S OUT (X32)	Power supply OUT f or additional devices
U _A OUT (X32)	Power supply OUT for additional devices



Ground the device by means of the mounting screws of the fixing clips or the mounting plate or the DIN rail.

6.2 PROFIBUS pin assignment

The bus is connected via two B-coded M12 plug-in plugs. The incoming bus (IN) is a plug and the outgoing bus (OUT) is a socket.

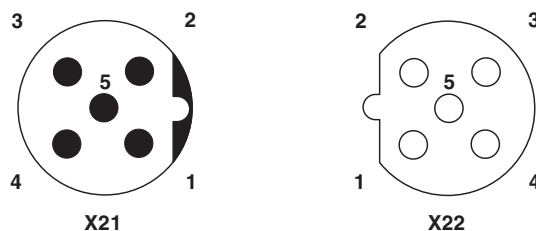

Figure 3 PROFIBUS pin assignment, B-coded

Pin	Signal	Specification	Description
1	VP	V	5 V termination resistor
2	RxD / TxD-N (A)	A, RS-485, PD	Inverted bus cable
3	DGND	V	0 V
4	RxD / TxD-P (B)	B, RS-485, PU	Non-inverted bus cable
5	Not used	-	-

- A = A line
- B = B cable
- RS-485 = RS-485 level, bidirectional
- V = Power supply
- PU = Pullup
- PD = Pulldown



The shield is connected to FE in the device.



The thread is used for additional shielding.

6.3 Pin assignment of the power supply U_S/U_A

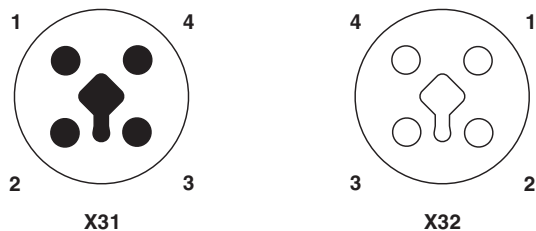

Figure 4 Pin assignment of the power supply, T-coded

Pin	IN	OUT	Conductor colors
1	+24 V DC (U_S)	+24 V DC (U_S)	Brown
2	GND (U_A)	GND (U_A)	White
3	GND (U_S)	GND (U_S)	Blue
4	+24 V DC (U_A)	+24 V DC (U_A)	Black

6.4 Connecting inputs and outputs

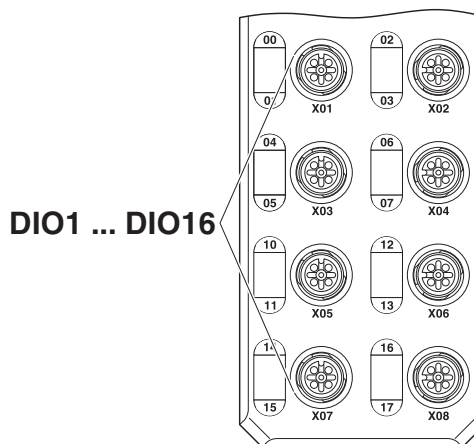

Figure 5 Input and output connections

Designation	Meaning
DIO1 ... DIO16 (X01 ... X08)	Inputs/outputs 1 ... 16

6.5 Pin assignment of the inputs and outputs

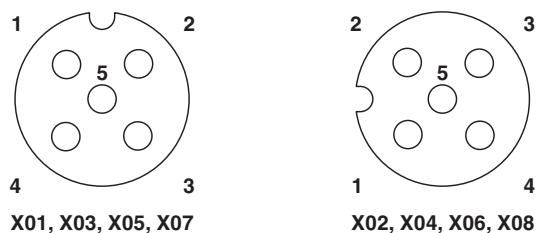

Figure 6 Pin assignment of the inputs and outputs, A-coded

Pin	Input/output socket
1	+24 V DC (U_S)
2	Input/output 2, 4, 6, ... 16
3	GND
4	Input/output 1, 3, 5, ... 15
5	FE

7 Connection example

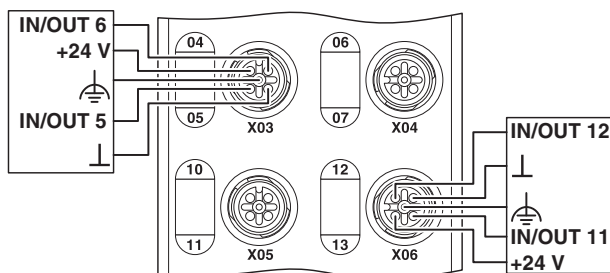

Figure 7 Example of connection of sensors and actuators

8 Connection notes



NOTE: Data corruption or loss

Implement the FE connection using mounting screws, in order to ensure immunity to interference.



NOTE: Device damage

To ensure IP65/IP67 protection, cover unused sockets with protective caps.



NOTE: Damage to the electronics

Only supply the sensors with the voltage U_S provided at the terminal points.



NOTE: Damage to the electronics

Observe the correct polarity of the supply voltages U_S and U_A in order to prevent damage to the device.



NOTE: Malfunction

When connecting the sensors and actuators, observe the assignment of the connections to the PROFIBUS input and output data.



Secure the device to a level surface or to a profile. Do not use this device to bridge gaps, in order to prevent forces being transmitted via the device.



Use standard M5 screws with toothed lock washer and self-locking nuts. Observe the maximum torque of the screws.

9 Configuration via rotary encoding switch

Addresses are set using two rotary coding switches. Switch x10 is used to set the position in tens (x10) and switch x1 is used to set the position in units (x1). The address can be set between 1 and 126.

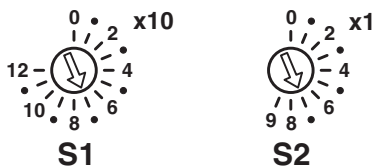

Figure 8 PROFIBUS rotary encoding switch

S1	S2	Code	Function
0	0	00	Reserved
0 ... 12	1 ... 5	01 ... 125	Manual address assignment
12	6	126	Setting the slave address (set slave address command)
12	7	127	Reserved
12	8	128	Reserved
12	9	129	Reserved



A new address value is only applied on device power up.

10 Local status and diagnostic indicators

10.1 Indicators for bus and power supply

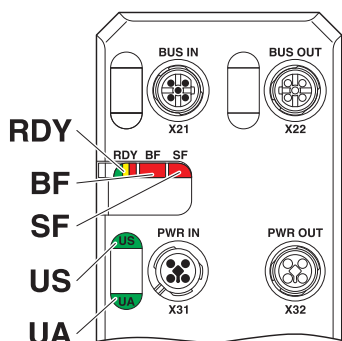

Figure 9 LEDs for bus and power supply

Designation	Color	Meaning	State	Description
RDY	Green/ yellow/ red	Ready	Green on	Device is ready to operate.
			Yellow flashing	Firmware update is being performed.
			Flashing green/ yellow	Over- or undervoltage at U_S Temperature of the device is in the critical area. And red US LED: sensor supply overload
			Red on	Rotary encoding switches are set to an invalid/reserved position.
			Off	Device is not ready for operation.
			Off	Device is not ready for operation.
BF	Red	Bus Fault	Red on	No communication on PROFIBUS Device is starting up. No baud rate detected by device.
			Red flashing	Device has not been configured by the master.
			Red flashing	Device configuration does not match. Invalid parameter data received from the master. Invalid bus address
			Red flashing	The device is in the clear or stop state. The outputs are in the safe state.
			Off	No error
			Off	No error
SF	Red	Group error	Red on	Device-specific diagnostics present, e.g., short circuit at the I/O devices. Hardware is faulty. Device data or parameter data do not match.
			Red on	Device-specific diagnostics present, e.g., short circuit at the I/O devices. Hardware is faulty. Device data or parameter data do not match.
			Off	No error
US	Green/ red	U_{Sensorik}	Green on	Communications power/sensor voltage present
			Off	Communications power/sensor voltage not present or too low
			Red on	Sensor voltage overload
UA	Green	U_{Aktorik}	On	Actuator voltage is present.
			Off	Actuator voltage is not present.

10.2 Input and output indicators

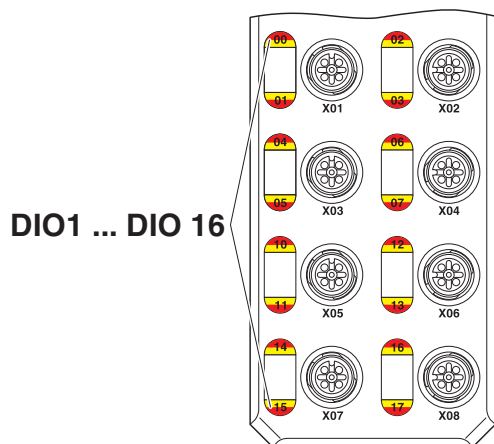

Figure 10 Input and output indicators

Designation	Color	Meaning	State	Description
00 ... 07, 10 ... 17	Yellow	Status of the inputs and outputs when used as an input	On	Input is set.
			Off	Input is not set.
00 ... 07, 10 ... 17	Yellow/red	Status of the inputs and outputs when used as an output	Yellow on	Output is set.
			Red on	Output is short circuited or overloaded.
			Off	Output is not set.



The numbering of the LEDs is as follows: the first number specifies the byte, the second number specifies the bit.

11 Process data

11.1 Assignment of the terminal points to the IN process data

The I/O data are mapped as follows:

Input process data																
Byte	0								1							
Bit	7	6	5	4	3	2	1	0	7	6	5	4	3	2	1	0
IN	07	06	05	04	03	02	01	00	17	16	15	14	13	12	11	10
Connection	X04		X03		X02		X01		X08		X07		X06		X05	
Pin	2	4	2	4	2	4	2	4	2	4	2	4	2	4	2	4
DI	8	7	6	5	4	3	2	1	16	15	14	13	12	11	10	9

Key:

Bit: Process data assignment
 IN: LED marking
 DI: Input of the device

11.2 Assignment of the terminal points to the OUT process data

The I/O data are mapped as follows:

Output process data																
Byte	0								1							
Bit	7	6	5	4	3	2	1	0	7	6	5	4	3	2	1	0
OUT	07	06	05	04	03	02	01	00	17	16	15	14	13	12	11	10
Connection	X04		X03		X02		X01		X08		X07		X06		X05	
Pin	2	4	2	4	2	4	2	4	2	4	2	4	2	4	2	4
DO	8	7	6	5	4	3	2	1	16	15	14	13	12	11	10	9

Key:

Bit: Process data assignment
 OUT: LED marking
 DO: Output of the device

11.3 Status module

The device has a status module in slot 1.

The status is mapped as follows.

Bit 31 ... bit 6	Bit 5	Bit 4	Bit 3	Bit 2	Bit 1	Bit 0
Reserved	Supply of the module electronics, sensors and actuators (U_S)		Reserved		Outputs	
	Undervoltage	Overload			Reserved	Overload/Short-circuit

11.4 Configuration of digital inputs and outputs

A channel, whether an input or an output, is configured by using the IN or OUT process data according to the channel function. Parameterization is not necessary.



If the channel is used as an output, the status of the channel is also mapped to the IN process data. This can be useful, e.g., for diagnostic purposes.
 If the channel is used as an input, the channel cannot simultaneously be used as an output.

12 Parameterization

This section provides a detailed description of the format of the parameters for the input and output devices. This may be useful when setting parameters using acyclic services or if there is no user interface for the simple selection of parameters.

Byte	Meaning
1 ... 7	DP standard
8 ... 10	DP/V1 standard
11 ... 13	Module parameter

Module parameter			
Byte	Meaning	Contents	
11	Behavior of the device	Bit 0 and Bit 1	Substitute value behavior
		Bit 1	00 _{bin} : "0" is output to all output bits
			01 _{bin} : "1" is output to all output bits
			10 _{bin} : hold last value
			11 _{bin} : substitute value
Other	Reserved		
12	Substitute values of individual channels 1 ... 8	Bit 0	Substitute value for channel 1 (X01.00)
		Bit 1	Substitute value for channel 2 (X01.01)
		Bit 2	Substitute value for channel 3 (X02.02)
		Bit 3	Substitute value for channel 4 (X02.03)
		Bit 4	Substitute value for channel 5 (X03.04)
		Bit 5	Substitute value for channel 6 (X03.05)
		Bit 6	Substitute value for channel 7 (X04.06)
		Bit 7	Substitute value for channel 8 (X04.07)
13	Substitute value behavior of individual channels 9 ... 16	Bit 0	Substitute value for channel 9 (X05.10)
		Bit 1	Substitute value for channel 10 (X05.11)
		Bit 2	Substitute value for channel 11 (X06.12)
		Bit 3	Substitute value for channel 12 (X06.13)
		Bit 4	Substitute value for channel 13 (X07.14)
		Bit 5	Substitute value for channel 14 (X07.15)
		Bit 6	Substitute value for channel 15 (X08.16)
		Bit 7	Substitute value for channel 16 (X08.17)

13 I&M functions

The following Information & Maintenance functions are supported:

I&M 0

I&M data	Access / data type	Presets
MANUFACTURER_ID	Read / 2 bytes	B0 _{hex} (Phoenix Contact GmbH & Co. KG)
ORDER_ID	Read / 20 bytes	-
SERIAL_Number	Read / 16 bytes	-
HARDWARE_Revision	Read / 2 bytes	-
SOFTWARE_Revision	Read / 4 bytes	-
REVISION_Counter	Read / 2 bytes	0000 _{hex} (reserved)
PROFILE_ID	Read / 2 bytes	F600 _{hex} (generic device)
PROFILE_SPECIFIC_TYPE	Read / 2 bytes	0003 _{hex} (IO module)
IM_VERSION	Read / 2 bytes	0102 _{hex} (Version 1.2)
IM_SUPPORTED	Read / 2 bytes	000E _{hex} (I&M 1 ... 3)

I&M 1

I&M data	Access / data type	Presets
TAG_FUNCTION	Read/write / 32 bytes	"20 _{hex} " (empty)
TAG_LOCATION	Read/write / 22 bytes	"20 _{hex} " (empty)

I&M 2

I&M data	Access / data type	Presets
INSTALLATION_DATE	Read/write / 16 bytes	"20 _{hex} " (empty)
RESERVED	Read/write / 38 bytes	0 _{hex}

I&M 3

I&M data	Access / data type	Presets
DESCRIPTOR	Read/write / 54 bytes	"20 _{hex} " (empty)

14 Sync/freeze mode

The device supports sync and freeze mode. The functions must be activated by the PROFIBUS master in the parameter data.

Input and output data is written or read at defined times with the sync and freeze commands.

If the device receives a sync command from the PROFIBUS master at any given time, the current OUT process data is transferred and frozen until the next sync command.

Similarly, the states of the inputs are transferred on the respective freeze command and are frozen until the next freeze command.

15 Diagnostic alarms

PROFIBUS enables the PROFIBUS device to store diagnostic information together with the error location and error type.

In the default upon delivery the alarms are enabled, however, they can be disabled with parameters on startup.

An incoming alarm informs the PROFIBUS device that diagnostic information has been entered.

When the diagnostic information has been removed, an outgoing alarm is sent to the device.

If at least one piece of diagnostic information is stored, the SF LED is on. If no diagnostic information is present, the SF LED is off.

The following PROFIBUS diagnostic messages are indicated by the PROFIBUS device:

Diagnostic messages	Status bit process data	Network-specific diagnostic mapping
Overtemperature device	-	Yes
Undervoltage U_S	Bit 5	Yes
Overload U_S	Bit 4	Yes
Overvoltage U_S	-	Yes
Overload/Short-circuit of an output	Bit 0	Yes



Channel diagnostics are always reported in groups of 4.
The LED status can be found in chapter 10.

16 Monitoring

A process data watchdog is integrated into the device to avoid uncontrolled setting/resetting of outputs in the event of an error.

If device outputs are set, the controlling process must be able to access the device.

In the event of an error, e.g., bus cable interrupted or function error in the controlling process, the device can respond appropriately via the process data watchdog.

When activating the process data watchdog, it is started by the first write process and the next write process is expected within the timeout period. During error-free operation, the write process is performed during the timeout period and the watchdog is restarted (triggered).



Reading calls do not trigger the process data watchdog.

If there is no triggering during the timeout period, an error occurred. Two responses follow:

- All outputs are set to the configured substitute value.
- The BF LED indicates the corresponding state.

17 Substitute value behavior

If PROFIBUS communication fails or if no valid process data is received from the PROFIBUS master, all device outputs are set to the parameterized substitute values.



SCATTERGOOD & JOHNSON LTD

ELECTRICAL ENGINEERING & FLUID CONTROL DISTRIBUTORS

Est.1899

At Scattergood & Johnson Ltd, we pride ourselves on being a technical distributor to specialist industries.

Working with a range of quality product suppliers across a number of specialist markets, we are not your average 'box shifter' - we are your technical and supply chain partner.

We fully support every product we sell - for free! Our internal team and external sales engineers can answer any product or application question, no matter the complexity.

Backing up this technical ability is a range of 50,000+ products available from stock for nationwide next day delivery (same day if required!), or you can collect what you need from any of our trade counters around the UK.

Select your specialist interest below to learn more about how we can help.



Online, In Branch and On the Road - Scattergood & Johnson Ltd, there when you need us.

www.scatts.co.uk