

# AXL E EC IOL8 DI4 M12 6M

**Axioline E EtherCAT® IO-Link device,  
metal housing, 8 IO-Link ports, 4 inputs,  
24 V DC, M12 fast connection technology**



Data sheet  
8539\_en\_10

© PHOENIX CONTACT 2019-09-02

## 1 Description

The Axioline E device is designed for use within an EtherCAT® network. It enables the operation of up to eight IO-Link sensors/actuators and is also used to acquire digital signals.

### EtherCAT® features

- Connection to EtherCAT® network using M12 connectors (D-coded)
  - 2 Ethernet-Ports
  - Transmission speed 100 Mbps
- Supports the EtherCAT® cycle time of min. 100 µs
- Automatic addressing
- Identification:
  - Rotary coding switch for assigning the ID for the "Explicit Device ID" mechanism
  - Configured Second Station Alias
- Hot Connect
- Acyclic data communication (CoE, FoE, EoE, and AoE mailbox protocols)
- Device description by means of ESI
- Supports distributed clocks (jitter << 1 µs)

- Specification: ETG.1000 V1.02, ETG.5001.3 (Annex K)
- Mapped as a modular EtherCAT® device using a modular device profile (MDP)
- Firmware can be updated
- Integrated web server for web-based management

### IO-Link features

- Connection of eight IO-Link devices
  - 4 IO-Link A ports with additional digital input
  - 4 IO-Link B ports with additional power supply
- Connection of IO-Link ports using M12 connectors (A-coded, 5-pos.)
- Parameterization of devices via the AoE protocol
- Parameter data storage on the master
- Parameterizable process data width
- IO-Link specification V1.1.2

### General features

- Diagnostic and status indicators
- Short-circuit and overload protection of the sensor supply
- IP65/67 degree of protection



EtherCAT® is a registered trademark and patented technology, licensed by Beckhoff Automation GmbH, Germany.



This data sheet is only valid in association with the corresponding documentation. Make sure you always use the latest documentation. It can be downloaded via the product at [phoenixcontact.net/products](https://www.phoenixcontact.net/products).



The firmware v2.2.x.x on the device is required for the functions described in the data sheet.

<b>2</b>	<b>Table of contents</b>	
1	Description .....	1
2	Table of contents .....	2
3	Ordering data .....	3
4	Technical data .....	4
5	Internal circuit diagram .....	9
6	Abbreviations used .....	9
7	Pin assignment .....	10
7.1	EtherCAT® and power supply connection .....	10
7.2	EtherCAT® pin assignment .....	10
7.3	Pin assignment of the power supply $U_S/U_A$ .....	10
7.4	Connecting IO Link Ports and inputs .....	11
7.5	Pin assignment of the IO-Link ports and inputs .....	11
8	Connection example .....	12
9	Connection notes .....	12
10	Identification .....	13
10.1	Configuration via rotary encoding switch (Device Identification Value) .....	13
10.2	Configured Second Station Alias .....	13
10.3	Hot Connect .....	13
11	Local status and diagnostic indicators .....	14
11.1	Indicators for EtherCAT® and power supply .....	14
11.2	Displaying the IO-Link ports and inputs .....	15

### 3 Ordering data

Description	Type	Order No.	Pcs./Pkt.
Axioline E-EtherCAT® IO-Link device in a metal housing with 8 IO-Link ports and 4 digital inputs, 24 V DC, M12 fast connection technology degree of protection: IP65/67	AXL E EC IOL8 DI4 M12 6M	2701531	1
Accessories	Type	Order No.	Pcs./Pkt.
An M12 screw plug for the unoccupied M12 sockets of the sensor/actuator cable, boxes and flush-type connectors (Protection and sealing elements)	PROT-M12	1680539	5
Mounting plate for Axioline E metal devices (Assembly)	AXL E MP 60	2701761	1
Snap-in markers, Sheet, white, unlabeled, can be labeled with: THERMOMARK PRIME, THERMOMARK CARD, BLUEMARK ID, BLUEMARK ID COLOR, BLUEMARK CLED, TOPMARK NEO, TOPMARK LASER, mounting type: snapped into marker carrier, lettering field size: 7 x 10 mm (Marking)	UCT-EM (7X10)	0830765	10
Documentation	Type	Order No.	Pcs./Pkt.
User manual, English: Axioline E: system and installation	UM EN AXL E SYS INST	-	-
User manual, English: Network-specific properties of the Axioline E-EtherCAT® IO-Link devices	UM EN AXL E EC IOL	-	-
Application note, English: Updating the firmware of Axioline E-EtherCAT® devices with TwinCAT®	AH EN FIRMWARE UPDATE AXL E EC	-	-
Application note, English: Measures to protect network-capable devices with Ethernet connection against unauthorized access	AH EN INDUSTRIAL SECURITY	-	-
Application note, English: Wiring of Axioline E devices	AH EN AXL E CABLE / WIRING	-	-
Quickstart, English: Startup of Axioline E-EtherCAT® IO-Link devices with CODESYS	UM QS EN AXL E EC IOL CODESYS	-	-

#### Additional ordering data

For additional accessories, visit [phoenixcontact.net/products](http://phoenixcontact.net/products).

## 4 Technical data

### Dimensions (nominal sizes in mm)

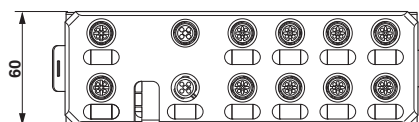
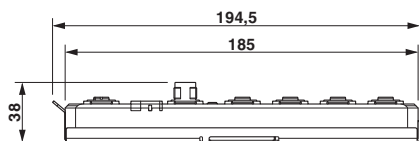

Width	60 mm
Height	185 mm
Depth	38 mm
Note on dimensions	The height is 194.5 mm including the mounting plate. With fixing clips pulled out, the height is 212 mm. The depth is 38 mm including the mounting plate (30.5 mm without the mounting plate).

### General data

Housing material	Zinc die-cast
Weight	750 g
Ambient temperature (operation)	-25 °C ... 60 °C



#### CAUTION: Risk of burns

If the device is used at an ambient temperature above 50°C, the contact temperature of metal surfaces may exceed 70°C.

Ambient temperature (storage/transport)	-25 °C ... 85 °C
Permissible humidity (operation)	5 % ... 95 %
Permissible humidity (storage/transport)	5 % ... 95 %
Air pressure (operation)	70 kPa ... 106 kPa (up to 3000 m above sea level)
Air pressure (storage/transport)	70 kPa ... 106 kPa (up to 3000 m above sea level)
Degree of protection	IP65/67
Protection class	III, IEC 61140, EN 61140, VDE 0140-1

### Connection data

Connection method	M12 connector
-------------------	---------------

### Interface EtherCAT®

Number	2
Designation connection point	Copper cable
Connection method	M12 fast connection technology
Note on connection method	D-coded

**Interface EtherCAT®**

Number of positions	4
Transmission speed	100 Mbps (with auto negotiation)
Cycle Time	< 100 µs

**EtherCAT®**

Equipment type	EtherCAT® slave
Mailbox protocols	CANopen® over EtherCAT®, File access over EtherCAT®
Type of addressing	Auto-increment addressing Fixed position addressing Logical addressing
Specification	ETG.1000 V1.02

**Supply: Module electronics and sensors (U<sub>S</sub>)**

Connection method	M12 connector (T-coded)
Number of positions	4
Supply voltage	24 V DC
Nominal supply voltage range	19.5 V DC ... 31.2 V DC (including all tolerances, including ripple)
Current consumption	typ. 180 mA ±15 % (at 24 V DC) max. 12 A

**Supply: Actuators (U<sub>A</sub>)**

Connection method	M12 connector (T-coded)
Number of positions	4
Supply voltage	24 V DC
Nominal supply voltage range	18 V DC ... 31.2 V DC (including all tolerances, including ripple)
Current consumption	typ. 28 mA ±15 % (at 24 V DC) max. 12 A

**IO-Link ports: Class A**

Number of ports	4
Connection method	M12 fast connection technology
Connection method	3-wire
MasterCycleTime	min. 2 ms (PDInput* + PDOOutput* + OnReqData* <= 17 Byte; COM3) * see "IO-Link Interface and System Specification V1.1.2"

**IO-Link ports: Class B**

Number of ports	4
Connection method	M12 fast connection technology
Connection method	3-wire
MasterCycleTime	min. 2 ms (PDInput* + PDOOutput* + OnReqData* <= 17 Byte; COM3) * see "IO-Link Interface and System Specification V1.1.2"

**IO-Link port supply**

Nominal voltage for I/O supply	24 V DC
Nominal current for every IO-Link port	150 mA at C/Q (pin 4), maximum of 1.6 A over all 8 IO-Link C/Q and L+ cables) 200 mA at L+/L- (pin 1 and pin 3), during startup, up to 1.6 A for short periods max. 2 A at U <sub>A</sub> (IO-Link B ports, pin 2 and pin 5)
Overload protection	yes
Permissible conductor length to the sensor	< 20 m

**IO-Link ports in digital input (DI) mode**

Number of inputs	max. 8 (EN 61131-2 type 1)
Connection method	M12 connector, X01 ... X04 have double occupancy
Connection method	3-wire
Nominal input voltage	24 V DC
Nominal input current	typ. 3 mA
Sensor current per channel	max. 200 mA (from L+/L-)
Total sensor current	max. 1.6 A (from L+/L-)
Input voltage range "0" signal	-0.3 V DC ... 5 V DC
Input voltage range "1" signal	15 V DC ... 30 V DC
Input filter time	< 1000 µs
Input frequency	0.5 kHz
Overload protection	yes
Short-circuit protection for the sensor supply	yes

**IO-Link ports in digital output (DO) mode**

Number of outputs	max. 8
Connection method	M12 connector, X01 ... X04 have double occupancy
Connection method	3-wire
Nominal output voltage	24 V DC
Maximum output current per channel	150 mA
Maximum output current per module	1.2 A
Nominal load, ohmic	3.6 W (160 Ω, at nominal load)
Nominal load, inductive	3.6 VA (0.8 H, 160 Ω, at nominal load)
Signal delay	max. 150 µs (when switched on) max. 200 µs (when switched off)
Switching rate	1 per second, maximum (at nominal inductive load) 5500 per second, maximum (at nominal ohmic load)
Limitation of the voltage induced on circuit interruption	-15 V DC
Output voltage when switched off	max. 1 V
Output current when switched off	max. 300 µA
Behavior with overload	Shutdown with automatic restart
Overload protection	yes
Short-circuit protection	yes

**Digital inputs at pin 2 for type A ports**

Number of inputs	4 (EN 61131-2 type 1)
Connection method	M12 connector, X01 ... X04 have double occupancy
Connection method	3-wire
Nominal input voltage	24 V DC
Nominal input current	typ. 3 mA
Sensor current per channel	max. 200 mA (from L+/L-)
Total sensor current	max. 1.6 A (from L+/L-)
Input voltage range "0" signal	-0.3 V DC ... 5 V DC
Input voltage range "1" signal	15 V DC ... 30 V DC
Input filter time	< 1000 $\mu$ s
Input frequency	0.5 kHz
Overload protection	yes
Short-circuit protection for the sensor supply	yes

**Electrical isolation/isolation of the voltage areas**

Test section	Test voltage
24 V supply (communications power and sensor supply, IO-Link ports)/bus connection (Ethernet 1)	500 V AC, 50 Hz, 1 min.
24 V supply (communications power and sensor supply, IO-Link ports)/bus connection (Ethernet 2)	500 V AC, 50 Hz, 1 min.
24 V supply (communications power and sensor supply, IO-Link ports)/FE	500 V AC, 50 Hz, 1 min.
Bus connection (Ethernet 1)/FE	500 V AC, 50 Hz, 1 min.
Bus connection (Ethernet 2)/FE	500 V AC, 50 Hz, 1 min.
Bus connection (Ethernet 1)/bus connection (Ethernet 2)	500 V AC, 50 Hz, 1 min.
24 V supply (actuator supply)/24 V supply (communications power and sensor supply, IO-Link ports)	500 V AC, 50 Hz, 1 min.
24 V supply (actuator supply)/bus connection (Ethernet 1)	500 V AC, 50 Hz, 1 min.
24 V supply (actuator supply)/bus connection (Ethernet 2)	500 V AC, 50 Hz, 1 min.
24 V supply (actuator supply)/FE	500 V AC, 50 Hz, 1 min.

**Mechanical tests**

Vibration resistance in acc. with EN 60068-2-6/IEC 60068-2-6	5g
Shock in acc. with EN 60068-2-27/IEC 60068-2-27	30g, 11 ms period, half-sine shock pulse
Continuous shock in acc. with EN 60068-2-27/IEC 60068-2-27	10g

**Conformance with EMC Directive 2014/30/EU****Noise immunity test in accordance with EN 61000-6-2**

Electrostatic discharge (ESD) EN 61000-4-2/IEC 61000-4-2	Criterion B, 6 kV contact discharge, 8 kV air discharge
--	---

Electromagnetic fields EN 61000-4-3/IEC 61000-4-3	Criterion A, Field intensity: 10 V/m
---	--------------------------------------

Fast transients (burst) EN 61000-4-4/IEC 61000-4-4	Criterion B, 2 kV
--	-------------------

Transient overvoltage (surge) EN 61000-4-5/IEC 61000-4-5	Criterion B, DC supply lines: $\pm 0.5$ kV/ $\pm 0.5$ kV (symmetrical/asymmetrical)
--	---

Conducted interference EN 61000-4-6/IEC 61000-4-6	Criterion A; Test voltage 10 V
---	--------------------------------

<b>Noise emission test as per EN 61000-6-4</b>	Class A
--	---------

**Approvals**

For the latest approvals, please visit [phoenixcontact.net/products](http://phoenixcontact.net/products).

## 5 Internal circuit diagram

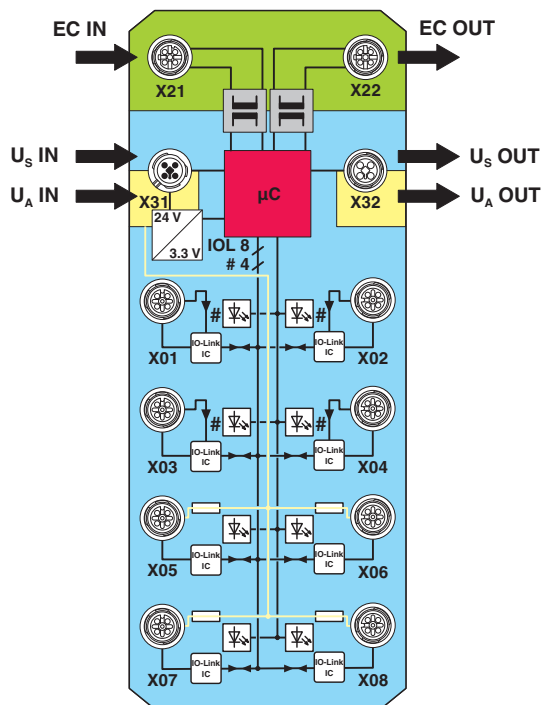

Key:

Green area: Network  
 Blue area:  $U_S$   
 Yellow area:  $U_A$

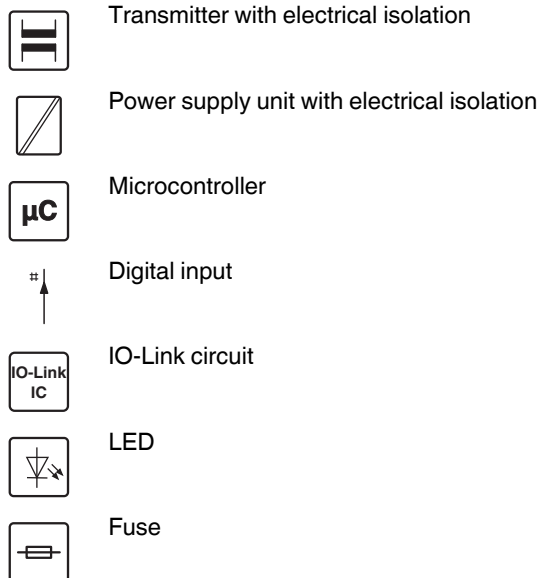

Figure 1 Internal wiring of connections

## 6 Abbreviations used

- CoE CAN application layer over EtherCAT®
- FoE File access over EtherCAT®
- EoE Ethernet over EtherCAT®
- AoE ADS (Automation Device Specification) over EtherCAT®

## 7 Pin assignment

### 7.1 EtherCAT® and power supply connection

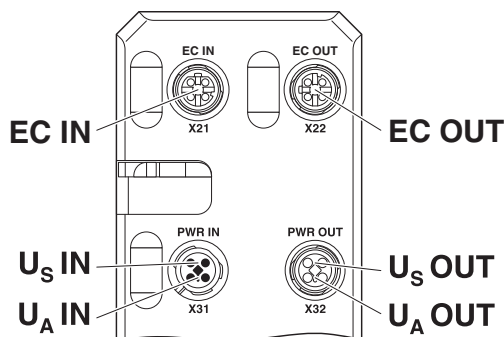

Figure 2 Connections for EtherCAT® and voltage supply

Designation	Meaning
EC IN (X21)	EtherCAT® IN
EC OUT (X22)	EtherCAT® OUT
U <sub>S</sub> IN (X31)	Power supply IN (logic and sensors)
U <sub>A</sub> IN (X31)	Power supply IN (actuators)
U <sub>S</sub> OUT (X32)	Power supply OUT for additional devices
U <sub>A</sub> OUT (X32)	Power supply OUT for additional devices



Make sure that the power supply U<sub>A</sub> and the power supply U<sub>S</sub> of two independent connected, electrically isolated power supplies takes place.

### 7.2 EtherCAT® pin assignment

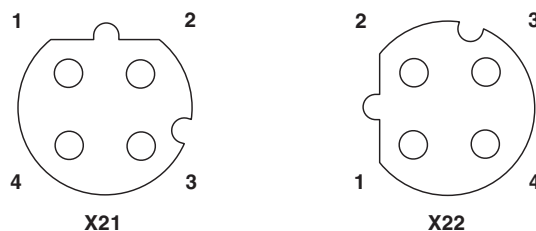

Figure 3 Ethernet pin assignment, D-coded

Pin	EC IN (X21)	EC OUT (X22)
1	TX+	TX+
2	RX+	RX+
3	TX-	TX-
4	RX-	RX-



The shield is connected to FE in the device.



The thread is used for additional shielding.

### 7.3 Pin assignment of the power supply U<sub>S</sub>/U<sub>A</sub>

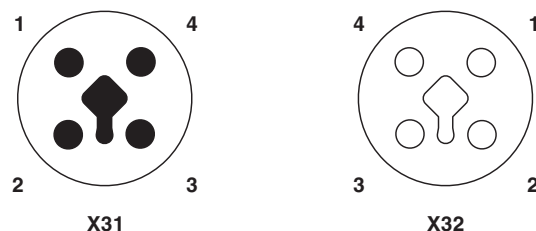

Figure 4 Pin assignment of the power supply, T-coded

Pin	IN	OUT	Conductor colors
1	+24 V DC (U <sub>S</sub> )	+24 V DC (U <sub>S</sub> )	Brown
2	GND (U <sub>A</sub> )	GND (U <sub>A</sub> )	White
3	GND (U <sub>S</sub> )	GND (U <sub>S</sub> )	Blue
4	+24 V DC (U <sub>A</sub> )	+24 V DC (U <sub>A</sub> )	Black



Ground the device by means of the mounting screws of the fixing clips or the mounting plate or the DIN rail.

7.4 Connecting IO Link Ports and inputs

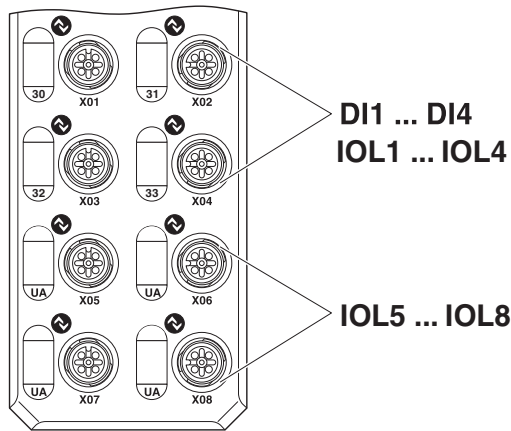

Figure 5 IO-Link port and digital input connections

Designation	Meaning
DI1 ... DI4 (X01 ... X04)	Inputs 1 ... 4 (pin 2)
IOL1 ... 4 (X01 ... X04)	IO-Link A ports 1 ... 4
IOL 5 ... 8 (X05 ... X08)	IO-Link B ports 5 ... 8



**IO-Link A port**

The IO-Link A port is assigned an additional hardwired DI (digital input) at pin 2.

**IO-Link B port**

The IO-Link B port has an additional supply voltage via pin 2 and 5. This port is suitable for connecting devices that have a higher current consumption. There are max. 2 A nominal current provided.

**Operating modes**

The C/Q cable (pin 4) can be configured independently of the other pins.

The IO-Link ports can be operated in the following operating modes:

- DI (behaves like a digital input)
- DO (behaves like a digital output)
- DI with IO-Link
- IO-Link

7.5 Pin assignment of the IO-Link ports and inputs

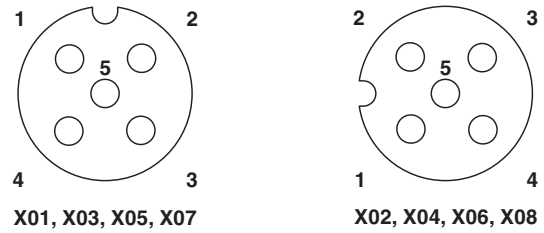

Figure 6 IO-Link ports pin assignment, A-coded

Pin	IO-Link A ports (X01 ... X04)	IO-Link B ports (X05 ... X08)
1	24 V DC (L+)	24 V DC (L+)
2	DI	24 V DC (U <sub>A</sub> )
3	GND (L-)	GND (L-)
4	C/Q, I/O link data transmission cable	C/Q, I/O link data transmission cable
5	Not used	GND (U <sub>A</sub> )



**NOTE: Sensor damage**

When connecting an IO-type A sensor to an IO-Link B port that a voltage is applied to pin 2 and pin 5. Do not connect it to the sensor. Use a three-conductor cable between port and sensor, e.g., cable type SAC-3P-M12MS/.../... Order No. 1696662.



**Nominal current at L+/L-**

Pins 1 and pin 3 provide a nominal current of 200 mA, maximum. Higher currents are briefly permitted during startup. The current is then limited electronically.

## 8 Connection example

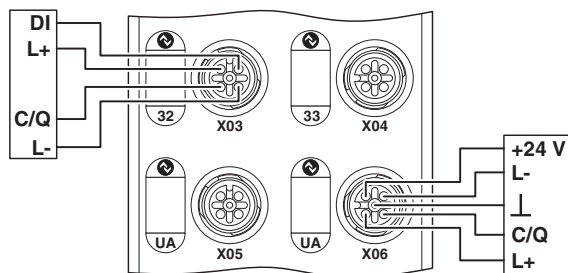

Figure 7 Typical connection of IO Link devices (A ports, X03) and (B ports, X06)

## 9 Connection notes



**NOTE: Data corruption or loss**

Implement the FE connection using mounting screws, in order to ensure immunity to interference.



**NOTE: Device damage**

To ensure IP65/67 degree of protection, cover unused sockets with protective caps.



**NOTE: Damage to the electronics**

Only supply the IO-Link master and the IO-Link devices with the voltage  $U_S$  and  $U_A$  provided at the terminal points.



**NOTE: Damage to the electronics**

Observe the correct polarity of the supply voltages  $U_S$  and  $U_A$  in order to prevent damage to the device.



**NOTE: Malfunction**

When connecting the IO-Link devices, observe the assignment of the connections to the EtherCAT<sup>®</sup> input data.



Secure the device to a level surface or to a profile. Do not use this device to bridge gaps, in order to prevent forces being transmitted via the device.



Use standard M5 screws with toothed lock washer and self-locking nuts. Observe the maximum torque of the screws.

## 10 Identification

In the case of EtherCAT® devices, a distinction is made between address assignment and identification.

**Addresses** are used for direct communication between the EtherCAT® master and the relevant slave. In doing so, the master assigns each slave a unique 16-bit address.

**Identifications** are used to uniquely identify a slave in an EtherCAT® network.

Identifications for AXL E EtherCAT® devices are:

- Device Identification Value
- Configured Second Station Alias

### 10.1 Configuration via rotary encoding switch (Device Identification Value)

You can configure the address assignment using the rotary coding switch.

After modifying the switch position, restart the device, as the modification to the switch position does not take effect during operation.

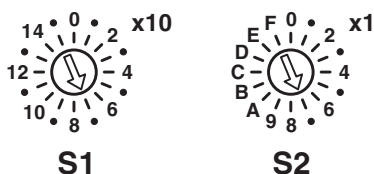

Figure 8 Rotary encoding switch

The code results from the sum of S1 x 10 plus S2 x 1. The image shows code 77 (7 x 10 + 7).

S1	S2	Code	Function
0 ... 15	0 ... 09	01 ... 159	Device Identification Value
Other			Reserved

### Switch position 01 ... 159

Set the EtherCAT® explicit device identification manually with this switch position.



The device is ready for operation after powering up, as soon as the RDY LED lights up green.  
A connection to the device cannot be established in the firmware startup phase.  
As soon as the RDY LED lights up green, a new switch position can be selected on the rotary coding switch and the device can be restarted.

### Reserved/invalid switch position

The device starts with the previous settings, e.g., with the settings that were valid before the device was restarted.

### 10.2 Configured Second Station Alias

For information on how to use the “Configured Second Station Alias” identification, please consult your configuration software.

### 10.3 Hot Connect

The Hot Connect functionality allows preconfigured sections to be removed from or added to the data traffic before the start or during operation of the system. This can be carried out by disconnecting/connecting the communication line or by switching a device on/off, for example. This is called “flexible topology” or “Hot Connect”.

## 11 Local status and diagnostic indicators

### 11.1 Indicators for EtherCAT® and power supply

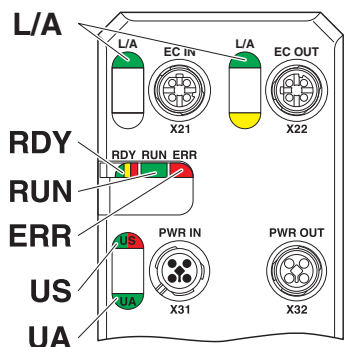

Figure 9 Indicators for EtherCAT® and power supply

Designation	Color	Meaning	State	Description
L/A	Green	Link/Activity	Green on	Connection is present at EC IN/EC OUT.
			Off	Connection is not present at EC IN/EC OUT.
RDY	Green/ yellow/ red	Ready	Green on	Device is ready to operate.
			Flashing yellow	Firmware update is being performed.
			Flashing green/ yellow	Overvoltage or undervoltage at $U_S$
				Temperature of the device is in the critical range.
				Failure of the actuator supply $U_A$
				Overvoltage/undervoltage of the actuator supply $U_A$
			Red on	Rotary coding switches are set to an invalid/reserved position.
Off	Device is not ready for operation.			
RUN	Green	RUN	Off	Device is in the Init state.
			Flashing slowly (2.5 Hz)	Device is in the Pre-Operational state.
			Single pulse	200 ms on, 1000 ms off, device is in the Safe-Operational state.
			Green on	Device is in the Operational state.
			Flashing (10 Hz)	Device is in the Bootstrap state.
ERR	Red	Error	On	Critical error in the device
			Flashing slowly (2.5 Hz)	Configuration error, a state transition initiated by the master cannot be executed.
			Single pulse	Local application error
			Double pulse	Watchdog timeout. The EtherCAT® watchdog for monitoring the process data has elapsed.
			Off	No error

Designation	Color	Meaning	State	Description
US	Green/ red	U <sub>Sensors</sub>	Green on	Communications power/sensor voltage is too low.
			Off	Communications power/sensor voltage is not present or too low.
			Red on	Sensor voltage overload
UA	Green	U <sub>Actuators</sub>	On	Actuator is voltage present.
			Off	Actuator is voltage not present.

11.2 Displaying the IO-Link ports and inputs

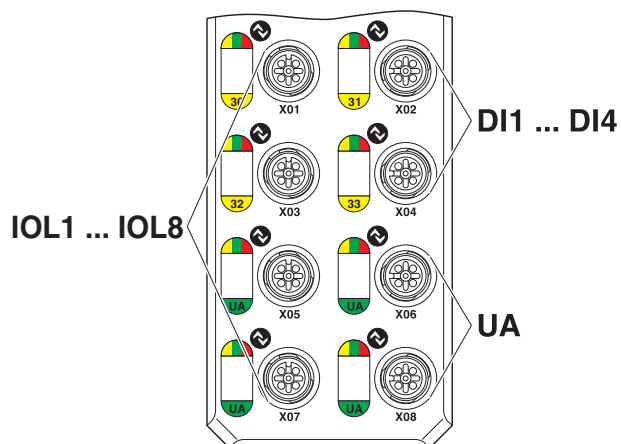

Figure 10 Displaying the IO-Link port and inputs

Designation	Color	Meaning	State	Description
IO-Link LED	Green/ yellow/ red	Status of the IO-Link ports (X01 ... X08)	Green on	In IO-Link mode: IO-Link communication present
			Green flashing	In IO-Link mode: no IO-Link communication
			Yellow on	The digital input or output is set in DI or DO mode.
			Red on	In IO-Link mode: IO-Link communication error
			Red on	In IO-Link mode: overload of the L+/L- cable
			Red on	In DI or DO mode: overload of the L+/L- cable
			Red on	Overload of the C/Q cable
			Off	The digital input or output is not set in DI or DO mode.
30 ... 33	Yellow	Status of the digital inputs	On	Input is set.
			Off	Input is not set.
UA	Green/ red	Actuator supply for X05 ... X08	Green on	Actuator voltage is present.
			Off	Actuator voltage is not present.
			Red on	Short circuit between pin 2 and pin 5



The numbering of the LEDs is as follows: the first number specifies the byte, the second number specifies the bit.



# SCATTERGOOD & JOHNSON LTD

ELECTRICAL ENGINEERING & FLUID CONTROL DISTRIBUTORS

Est.1899

At Scattergood & Johnson Ltd, we pride ourselves on being a technical distributor to specialist industries.

Working with a range of quality product suppliers across a number of specialist markets, we are not your average 'box shifter' - we are your technical and supply chain partner.

We fully support every product we sell - for free! Our internal team and external sales engineers can answer any product or application question, no matter the complexity.

Backing up this technical ability is a range of 50,000+ products available from stock for nationwide next day delivery (same day if required!), or you can collect what you need from any of our trade counters around the UK.

Select your specialist interest below to learn more about how we can help.

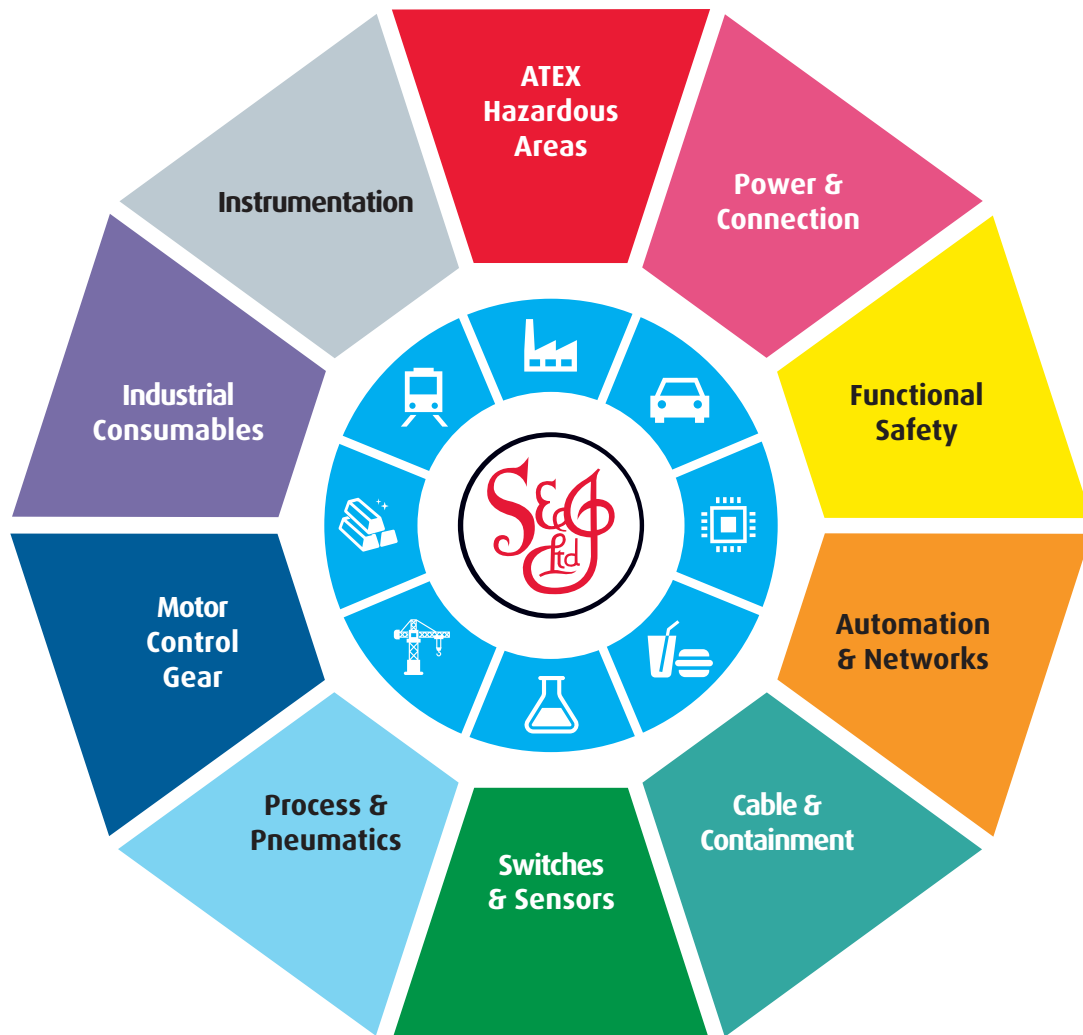

Online, In Branch and On the Road - Scattergood & Johnson Ltd, there when you need us.

# [www.scatts.co.uk](http://www.scatts.co.uk)