

AXL F DI8/1 DO8/1 1H

Axioline F digital input and output module, 8 inputs, 24 V DC, 8 outputs, 24 V DC, 500 mA, single-conductor connection technology



Data sheet
8670_en_02

© PHOENIX CONTACT 2014-04-30

1 Description

The module is designed for use within an Axioline F station.

It is used to acquire and output digital signals.

The filter times of the inputs can be set to increase noise immunity.

Filter times of 100 μ s allow the user to implement a counter function with a maximum input frequency of 5 kHz in the application.

The outputs are short-circuit and overload-protected .

Input features

- 8 digital inputs according to EN 61131-2 type 1 and type 3
- 24 V DC, 2.4 mA
- Connection of sensors in 1-wire technology
- Filter times can be set in three increments: < 100 μ s, 1000 μ s or 3000 μ s
- Maximum input frequency: 5 kHz

Output features

- 8 digital outputs
- 24 V DC, 500 mA
- Connection of actuators in 1-wire technology

Features of Axioline F

- Minimum update time < 100 μ s
- Device type label stored
- Diagnostic and status indicators



This data sheet is only valid in association with the UM EN AXL F SYS INST user manual.



Make sure you always use the latest documentation.
It can be downloaded from the product at phoenixcontact.net/products.

2	Table of contents	
1	Description	1
2	Table of contents	2
3	Ordering data	3
4	Technical data	3
5	Maximum outputs power consumption when inductive loads are switched off	6
6	Internal circuit diagram	7
7	Terminal point assignment.....	8
8	Connection example.....	8
9	Local status and diagnostic indicators	9
10	Process data.....	10
11	Parameter, diagnostics and information (PDI)	10
12	Standard objects	11
	12.1 Objects for identification (device rating plate).....	11
	12.2 Object for multilingual capacity	12
	12.3 Diagnostics objects	12
	12.4 Objects for process data management.....	13
13	Application objects	14
	13.1 Substitute value (FF8Dhex: PD Output Substitute Configuration)	14
	13.2 Filter time (FF8Fhex: Input_Filter)	14
14	Device descriptions	14

3 Ordering data

Description	Type	Order No.	Pcs. / Pkt.
Axioline F digital input and output module, 8 inputs, 24 V DC, 8 outputs, 24 V DC, 500 mA, single-conductor connection technology (including bus base module and connectors)	AXL F DI8/1 DO8/1 1H	2701916	1
Accessories	Type	Order No.	Pcs. / Pkt.
Axioline F bus base module for housing type H (Replacement item)	AXL F BS H	2700992	5
Axioline F connector set (for e.g., AXL F DO16/1 1H) (Replacement item)	AXL CNS 2L-O/D/UO/E1	2700986	1
Zack marker strip for Axioline F (device labeling), in 2 x 20.3 mm pitch, unprinted, 25-section, for individual labeling with B-STIFT 0.8, X-PEN, or CMS-P1-PLOTTER (Marking)	ZB 20,3 AXL UNPRINTED	0829579	25
Zack marker strip, flat, in 10 mm pitch, unprinted, 10-section, for individual labeling with M-PEN 0,8, X-PEN, or CMS-P1-PLOTTER (Marking)	ZBF 10/5,8 AXL UNPRINTED	0829580	50
Insert label, Roll, white, Unlabeled, can be labeled with: THERMOMARK ROLL, THERMOMARK X, THERMOMARK S1.1, Mounting type: snapped into marker carrier, Lettering field: 35 x 28 mm (Marking)	EMT (35X28)R	0801602	1
Documentation	Type	Order No.	Pcs. / Pkt.
User manual, English, Axioline F: System and installation	UM EN AXL F SYS INST	-	-
User manual, English, Axioline F: Diagnostic registers, and error messages	UM EN AXL F SYS DIAG	-	-

4 Technical data

Dimensions (nominal sizes in mm)

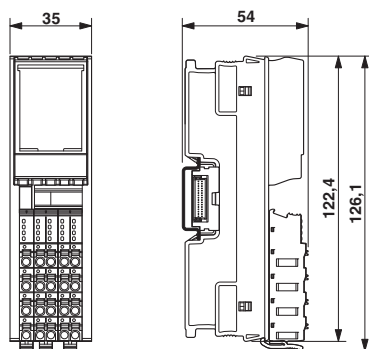

Width	35 mm
Height	126.1 mm
Depth	54 mm
Note on dimensions	The depth is valid when a TH 35-7.5 DIN rail is used (according to EN 60715).

General data

Color	traffic grey A RAL 7042
Weight	133 g (with connectors and bus base module)
Ambient temperature (operation)	-25 °C ... 60 °C
Ambient temperature (storage/transport)	-40 °C ... 85 °C
Permissible humidity (operation)	5 % ... 95 % (non-condensing)
Permissible humidity (storage/transport)	5 % ... 95 % (non-condensing)

General data

Air pressure (operation)	70 kPa ... 106 kPa (up to 3000 m above sea level)
Air pressure (storage/transport)	70 kPa ... 106 kPa (up to 3000 m above sea level)
Degree of protection	IP20
Protection class	III, IEC 61140, EN 61140, VDE 0140-1
Mounting position	Any (no temperature derating)

Connection data

Designation	Axioline F connector
Connection method	Push-in technology
Conductor cross section solid / stranded	0.2 mm ² ... 1.5 mm ² / 0.2 mm ² ... 1.5 mm ²
Conductor cross section [AWG]	24 ... 16

Interface Axioline F local bus

Connection method	Bus base module
Transmission speed	100 MBit/s

Communications power

Communications power U_{BUS}	5 V DC (via bus base module)
Current consumption from U_{BUS}	max. 120 mA
Power consumption at U_{BUS}	max. 600 mW

I/O supply

Digital input and output module supply U_{IO}	24 V DC
Maximum permissible voltage range	19.2 V DC ... 30 V DC (including all tolerances, including ripple)
Current consumption from U_{IO}	8 A (external fuse)
Power consumption at U_{IO}	typ. 440 mW (Without actuators), max. 97.35 W (of which 1.35 W internal losses)
Surge protection of the supply voltage	Electronic (35 V, 0.5 s)
Polarity reversal protection of the supply voltage	Parallel diode; with external 5 A fuse (for startup only)
Protection	max. 8 A (polarity reversal protection up to 5 A)



When using for the first time, protect the module with a 5 A fuse. If all the modules are correctly connected in the system, the 5 A fuse can be replaced by an 8 A fuse. you can now load the module up to 8 A.
Loads over 8 A are not permitted.

**NOTE: Damage to the electronics**

Provide the module with an external fuse to protect it against polarity reversal. The power supply unit must be able to supply four times the nominal current of the external fuse, to ensure that it trips in the event of an error.

Digital inputs

Number of inputs	8
Connection method	Push-in technology
Connection method	1-wire
Description of the input	EN 61131-2 types 1 and 3
Nominal input voltage	24 V DC
Nominal input current	2.4 mA
Current flow	Linear until nominal current is reached, then constantly approx. 2.4 mA
Input voltage range "0" signal	-3 V DC ... 5 V DC
Input voltage range "1" signal	11 V DC ... 30 V DC
Input filter time	3000 μ s (default), 1000 μ s, < 100 μ s
Process data update	< 100 μ s (bus-synchronous)
Polarity reversal protection of the inputs	Parallel diode (30 V, 5 s)

Digital outputs

Number of outputs	8
Connection method	Push-in technology
Connection method	1-wire
Nominal output voltage	24 V DC
Maximum output current per channel	500 mA
Maximum output current per device	4 A (external fuse)
Nominal load, ohmic	max. 12 W (48 Ω; with nominal voltage)
Nominal load, inductive	max. 12 VA (1.2 H; 48 Ω; with nominal voltage)
Nominal load, lamp	max. 12 W (at nominal voltage)
Signal delay	max. 100 μs (when switched on)
Signal delay	max. 100 μs (when switched off; with at least 50 mA load current)
Switching frequency	max. 10000 per second (with at least 50 mA load current)
Switching frequency	max. 1 per second (with inductive load)
Switching frequency	max. 16 per second (with nominal lamp load)
Load min.	10 kΩ
Energy consumption	see diagram
Limitation of the voltage induced on circuit interruption	-25.8 V ... -15 V
Output voltage when switched off	max. 1 V
Output current when switched off	max. 300 μA
Behavior with overload	Shutdown with automatic restart
Behavior with inductive overload	Output can be destroyed
Reverse voltage resistance to short pulses	Limited protection up to 0.5 A for 1 s

**NOTE: Damage to the electronics**

If there is a faulty external voltage (reverse voltage) at one of the outputs, the output may be destroyed. This may cause unintentional setting of further outputs.

Overcurrent shut-down	as of 0.7 A
Output current with ground connection interrupt when switched off	< 1 mA
Short-circuit protection, overload protection of the outputs	Electronic

Fieldbus data telegram

Fieldbus system	PROFIBUS DP
Required parameter data	3 Byte
Need for configuration data	7 Byte

Error messages to the higher level control or computer system

I/O supply failure	Yes
Short-circuit / overload of the digital outputs	Yes

Electrical isolation/isolation of the voltage areas

Test section	Test voltage
5 V communications power (logic), 24 V supply (I/O)	500 V AC, 50 Hz, 1 min
5 V supply (logic)/functional earth ground	500 V AC, 50 Hz, 1 min
24 V supply (I/O) / functional earth ground	500 V AC, 50 Hz, 1 min

Mechanical tests

Vibration resistance in acc. with EN 60068-2-6/IEC 60068-2-6	5 g
Shock in acc. with EN 60068-2-27/IEC 60068-2-27	30 g
Continuous shock according to EN 60068-2-27/IEC 60068-2-27	10 g

Conformance with EMC Directive 2004/108/EC

Noise immunity test in accordance with EN 61000-6-2

Electrostatic discharge (ESD) EN 61000-4-2/IEC 61000-4-2	Criterion B; 6 kV contact discharge, 8 kV air discharge
Electromagnetic fields EN 61000-4-3/IEC 61000-4-3	Criterion A; Field intensity: 10 V/m
Fast transients (burst) EN 61000-4-4/IEC 61000-4-4	Criterion B, 2 kV
Transient surge voltage (surge) EN 61000-4-5/IEC 61000-4-5	Criterion B; DC supply lines: ± 0.5 kV/ ± 0.5 kV (symmetrical/asymmetrical)
Conducted interference EN 61000-4-6/IEC 61000-4-6	Criterion A; Test voltage 10 V

Noise emission test according to EN 61000-6-3

Radio interference properties EN 55022	Class B
--	---------

Approvals

For the latest approvals, please visit phoenixcontact.net/products.

5 Maximum outputs power consumption when inductive loads are switched off



NOTE: Damage to the electronics

Restrict freewheeling voltage to a maximum of -17 V when using an external freewheeling circuit! The external freewheeling circuit does not function in the case of higher negative voltages.

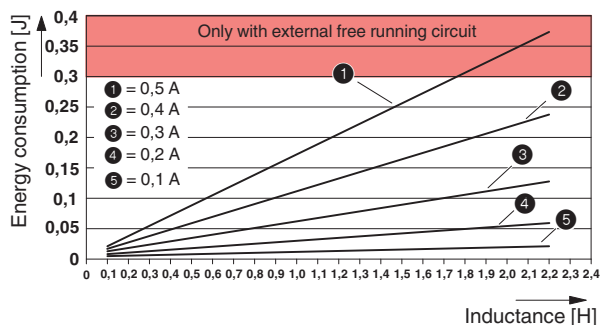

Figure 1 Maximum outputs power consumption when inductive loads are switched off

The specifications in the diagram refer to a maximum switching frequency of 1 Hz.

The diagram shows the maximum amount of energy that may be fed back into the corresponding output groups (outputs 1 to 4, 5 to 8) for each switch-off procedure when switching off an inductive load without external freewheeling circuit.

The current data refers to the ohmic DC voltage component of the inductive load.

6 Internal circuit diagram

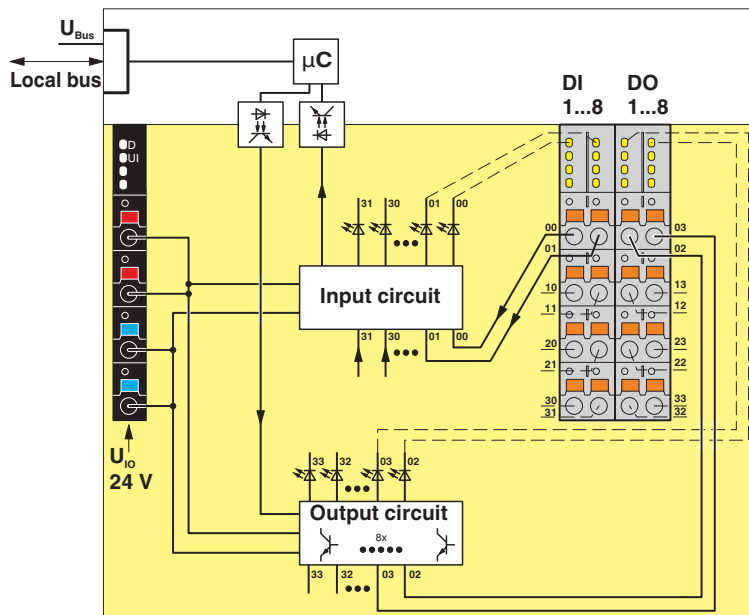

Figure 2 Internal wiring of the terminal points

Key:

Local bus Axioline F local bus
(hereinafter referred to as local bus)



Microcontroller



Transistor

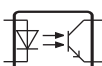

Optocoupler



LED



Power supply unit



Electrically isolated areas

Input circuit

Input circuit

Output circuit

Output configuration

7 Terminal point assignment

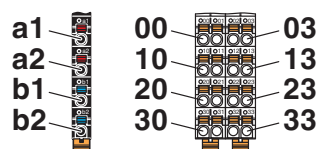

Figure 3 Terminal point assignment

Terminal point	Color	Assignment	
Supply voltage input			
a1, a2	Red	24 V DC (U _{IO})	Supply to digital input and output modules (internally jumpered)
b1, b2	Blue	GND	Reference potential of the supply voltage (internally jumpered)
Digital inputs			
00, 01, 10, 11	Orange	IN1 ... IN4	Digital inputs 1 ... 4
20, 21, 30, 31	Orange	IN5 ... IN8	Digital inputs 5 ... 8
Digital outputs			
02, 03, 12, 13	Orange	OUT1 ... OUT4	Digital outputs 1 ... 4
22, 23, 32, 33	Orange	OUT5 ... OUT8	Digital outputs 5 ... 8

8 Connection example

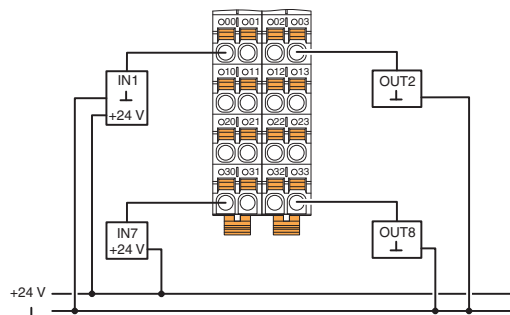

Figure 4 Typical connection of sensors and actuators when using external busbars

Ensure that GND of the sensors and actuators and GND for U_{IO} have the same potential.

9 Local status and diagnostic indicators

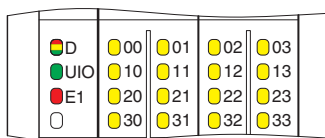

Figure 5 Local status and diagnostic indicators

Designation	Color	Meaning	State	Description
D	Red/ yellow/ green	Diagnostics of local bus communication		
		Power down	OFF	Device in (power) reset.
		Not connected	Red flashing	Device operating, but there is no connection to previous device.
		Reset	Red ON	Application reset Device operating, but there is still a connection to the previous device, the application is reset.
		Ready	Yellow ON	Device operating, there is still a connection to the previous device, but the device has not yet detected a valid cycle after power on.
		Connected	Yellow flashing	Valid data cycles have been detected, but the device is (not) yet part of the current configuration.
		Device application not active	Green/yellow alternating	Valid data cycles are being detected. The master application set the output data to valid, however, the slave application has not set the input data to valid as yet. The master application set the output data to valid, however, the slave application cannot set the output data to valid as yet.
		Active	Green flashing	The device functions, communication within the station is ok. The input data is not being read by the master application. The master application has not yet set the output data to valid. (For example, the connection to the controller is not yet established.)
UIO	Green	U _{input/output}	ON	Supply for digital input and output modules is available.
			OFF	Supply for digital input and output modules is not available.
E1	Red	Peripheral fault	ON	Short-circuit/overload of an output.
			OFF	No I/O error
00, 01, 10, 11, 20, 21, 30, 31	Yellow	Status of the inputs	ON	Input is set.
			OFF	Input is not set.
02, 03, 12, 13, 22, 23, 32, 33	Yellow	Status of the outputs	Yellow ON	Output is set.
			OFF	Output is not set.



For more information on the meaning of local diagnostic and status indicators, please refer to the UM EN AXL F SYS INST user manual.

10 Process data

The I/O data is displayed in S7-compatible format.

Input process data								
Byte	0							
Bit	7	6	5	4	3	2	1	0
Channel	8	7	6	5	4	3	2	1
Terminal point	31	30	21	20	11	10	01	00

Output process data								
Byte	0							
Bit	7	6	5	4	3	2	1	0
Channel	8	7	6	5	4	3	2	1
Terminal point	33	32	23	22	13	12	03	02

11 Parameter, diagnostics and information (PDI)

Parameter and diagnostic data as well as other information is transmitted via the PDI channel of the Axioline F station.

The standard and application objects stored in the module are described in the following section.

The following applies to all tables below:

Please refer to the UM EN AXL F SYS INST for an explanation of the object codes and data types.

Abbreviation	Meaning
A	Number of elements
L	Length of the elements
R	Read
W	Write



Every visible string is terminated with a zero terminator (00_{hex}). The length of a visible string element is therefore one byte larger than the amount of user data.



For detailed information on PDI and the objects, please refer to the UM EN AXL F SYS INST user manual.

12 Standard objects

12.1 Objects for identification (device rating plate)

Index (hex)	Object name	Object type	Data type	A	L	Rights	Meaning	Contents
Manufacturer								
0001	VendorName	Var	Visible String	1	16	R	Manufacturer name	Phoenix Contact
0002	VendorID	Var	Visible String	1	7	R	Manufacturer identification	00A045
0003	VendorText	Var	Visible String	1	49	R	Comment on the manufacturer	Components and systems for industrial automation
0012	VendorURL	Var	Visible String	1	30	R	URL of the manufacturer	http://www.phoenix-contact.com
Module - general								
0004	DeviceFamily	Var	Visible String	1	19	R	Device family	I/O digital IN-OUT
0006	ProductFamily	Var	Visible String	1	33	R	Product family	Axioline - High speed I/O system
000E	CommProfile	Var	Visible String	1	4	R	Communication profile	633
000F	DeviceProfile	Var	Visible String	1	5	R	Device profile	0010
0011	ProfileVersion	Record	Visible String	2	11; 20	R	Device profile version	2011-12-07; Basic Profile V2.0
003A	VersionCount	Array	Unsigned 16	4	4 * 2	R	Version counter	e.g., 0007 0001 0000 0000
Module - special								
0005	Capabilities	Array	Visible String	1	8	R	Properties	Nothing
0007	ProductName	Var	Visible String	1	21	R	Product designation	AXL F DI8/1 DO8/1 1H
0008	SerialNo	Var	Visible String	1	11	R	Serial number	xxxxxxxxxx (e. g., 1234512345)
0009	ProductText	Var	Visible String	1	55	R	Product text	8 digital inputs, adjustable filter, 8 digital outputs
000A	OrderNumber	Var	Visible String	1	8	R	Order No.	2701916
000B	HardwareVersion	Record	Visible String	2	11; 3	R	Hardware version	e. g., 2011-02-04; 00
000C	FirmwareVersion	Record	Visible String	2	11; 3	R	Firmware version	0000-00-00; --
000D	PChVersion	Record	Visible String	2	11; 6	R	Parameter channel version	2010-01-08; V1.00
0037	DeviceType	Var	Octet string	1	8	R	Module identification	00 C0 00 01 00 00 00 DD _{hex}
Use of the device								
0014	Location	Var	Visible String	1	59	R/W	Installation location	Can be filled out by the user.
0015	EquipmentIdent	Var	Visible String	1	59	R/W	Equipment identifier	Can be filled out by the user.
0016	ApplDeviceAddr	Var	Unsigned 16	1	2	R/W	User-defined device number	Can be filled out by the user.

12.2 Object for multilingual capacity

Index (hex)	Object name	Object type	Data type	A	L	Rights	Meaning	Contents
0017	Language	Record	Visible String	2	6; 8	R	Language	en-us; English

12.3 Diagnostics objects

Index (hex)	Object name	Object type	Data type	A	L	Rights	Assignment/content
0018	DiagState	Record		6	2; 1; 1; 2; 1; 1	R	Diagnostics state; see below

Diagnostics state (0018_{hex}: DiagState)

This object is used for a structured message of an error.

0018 _{hex} : DiagState (Read)					
Subindex	Data type	Length in bytes	Meaning	Contents	
0	Record	8	Diagnostic state	Complete diagnostics information	
1	Unsigned 16	2	Error number	0 ... 65535 _{dec}	
2	Unsigned 8	1	Priority	00 _{hex}	No error
				01 _{hex}	Error
				02 _{hex}	Warning
				81 _{hex}	Error removed
				82 _{hex}	Warning eliminated
3	Unsigned 8	1	Group	00 _{hex}	No error
				FF _{hex}	entire device
4	Unsigned 16	2	Error code	See table below	
5	Unsigned 8	1	More information follows	00 _{hex} (not supported)	
6	Visible String	1	Text	00 _{hex} (not supported)	



The message with the priority 81_{hex} or 82_{hex} is a one-time internal message to the bus coupler that is implemented onto the error mechanisms of the higher-level system by the bus coupler.



After all errors have been eliminated, it is automatically reset.

Error code and status of the local status and diagnostics indicators

Error code	Error	Priority	Group	D LED	UIO LED	E1 LED
0000 _{hex}	No error	00 _{hex}	00 _{hex}	Green ON	ON	OFF
3400 _{hex}	I/O supply failure	01 _{hex}	FF _{hex}	Flashing green/yellow	OFF	OFF
2344 _{hex}	Short-circuit/overload of an output.	02 _{hex}	FF _{hex}	Green ON	ON	Red on

12.4 Objects for process data management

Index (hex)	Object name	Object type	Data type	A	L	Rights	Assignment
0025	PDIN	Var	Octet string	1	1	R	Input process data
0026	PDOUT	Var	Octet string	1	1	R	Output process data
003B	PDIN_Descr	Array of Records		3	8; 2; 2	R	Description of the IN process data
003C	PDOUT_Descr	Array of Records		3	8; 2; 2	R	Description of the output process data

The objects 003B_{hex} and 003C_{hex} are only applicable to tools.

IN process data (0025_{hex}: PDIN)

You can read the IN process data of the module with this object.

The structure corresponds to the representation in the "Process data" section.

0025 _{hex} : PDIN (Read)			
Subindex	Data type	Length in bytes	Meaning
0	Octet string	1	Input process data

OUT process data (0026_{hex}: PDOUT)

You can write the output process data of the module with this object.

The structure corresponds to the representation in the "Process data" section.

0026 _{hex} : PDOUT (Read)			
Subindex	Data type	Length in bytes	Meaning
0	Octet string	1	Output process data

13 Application objects

Index (hex)	Object name	Object type	Data type	A	L	Rights	Assignment
FF8D	PD Output Substitute Configuration	Var	Unsigned 8	1	1	R/W	Substitute value
FF8F	Input_Filter	Var	Unsigned 8	1	1	R/W	Filter time

13.1 Substitute value (FF8D_{hex}: PD Output Substitute Configuration)

Configure the substitute value with which the module is to be operated with an application reset using this object.

FF8D _{hex} : PD Output Substitute Configuration (Read, write)				
Subindex	Data type	Length in bytes	Contents	
0	Var	1	00 _{hex} (Default)	"0" output to all output bits
			01 _{hex}	Hold last value

13.2 Filter time (FF8F_{hex}: Input_Filter)

Configure the filter time of the module using this object.

FF8F _{hex} : Input_Filter (read, write)				
Subindex	Data type	Length in bytes	Contents	
0	Var	1	00 _{hex} (Default)	3000 μ s
			01 _{hex}	1000 μ s
			02 _{hex}	< 100 μ s

14 Device descriptions

The device is described in the device description files.

The device descriptions for controllers from Phoenix Contact are included in PC Worx and the corresponding service packs.

The device description files for other systems are available for download at phoenixcontact.net/products in the download area of the bus coupler used.



SCATTERGOOD & JOHNSON LTD

ELECTRICAL ENGINEERING & FLUID CONTROL DISTRIBUTORS

Est.1899

At Scattergood & Johnson Ltd, we pride ourselves on being a technical distributor to specialist industries.

Working with a range of quality product suppliers across a number of specialist markets, we are not your average 'box shifter' - we are your technical and supply chain partner.

We fully support every product we sell - for free! Our internal team and external sales engineers can answer any product or application question, no matter the complexity.

Backing up this technical ability is a range of 50,000+ products available from stock for nationwide next day delivery (same day if required!), or you can collect what you need from any of our trade counters around the UK.

Select your specialist interest below to learn more about how we can help.



Online, In Branch and On the Road - Scattergood & Johnson Ltd, there when you need us.

www.scatts.co.uk