

AXL F DI16/1 DO16/1 2H

**Axioline F, digital I/O module,
digital inputs: 16, 24 V DC,
digital outputs: 16, 24 V DC, 500 mA**

Data sheet
106378_en_02

© PHOENIX CONTACT 2019-07-10



1 Description

The module is designed for use within an Axioline F station. It is used to acquire and output digital signals.

The filter times of the inputs can be adjusted to increase noise immunity.

Filter times of 100 µs enable the user to implement a counting function with a maximum input frequency of 5 kHz in the application.

The outputs are protected against short circuit and overload.

- Minimum update time of < 100 µs
- Device rating plate stored

Valid as of hardware revision 02, firmware revision 1.00.



The deviating behavior of the modules with an earlier hardware revision is documented in the corresponding points.

Features

- 16 digital inputs according to EN 61131-2 type 1 and type 3
- 24 V DC, 2.4 mA
- Connection of sensors in single-wire technology
- Filter times can be adjusted in three increments: < 100 µs, 1000 µs or 3000 µs
- Maximum input frequency: 5 kHz
- 16 digital outputs
- 24 V DC, 500 mA
- Connection of actuators in single-wire technology



This data sheet is only valid in association with the UM EN AXL F SYS INST user manual.



Make sure you always use the latest documentation.

It can be downloaded at: phoenixcontact.net/product/2702106

2	Table of contents	
1	Description	1
2	Table of contents	2
3	Ordering data	3
4	Technical data	3
5	Maximum outputs power consumption when inductive loads are switched off	7
6	Internal circuit diagram	8
7	Terminal point assignment.....	9
8	Connection example.....	9
9	Local diagnostic and status indicators	10
10	Process data.....	11
11	Parameter, diagnostics and information (PDI)	12
12	Standard objects	13
	12.1 Objects for identification (device rating plate).....	13
	12.2 Miscellaneous standard objects	14
	12.3 Diagnostics objects	15
	12.4 Objects for process data management.....	17
13	Application objects	18
	13.1 Substitute value behavior (FF8Dhex: PD Output Substitute Configuration)	18
	13.2 Filter time (FF8Fhex: Input_Filter)	18
14	Device descriptions	18

3 Ordering data

Description	Type	Order No.	Pcs./Pkt.
Axioline F, digital I/O module, digital inputs: 16, 24 V DC, connection method: 1-wire, digital outputs: 16, 24 V DC, 500 mA, connection method: 1-wire, transmission speed in the local bus: 100 Mbps, degree of protection: IP20, including bus base module and Axioline F connectors	AXL F DI16/1 DO16/1 2H	2702106	1
Accessories	Type	Order No.	Pcs./Pkt.
Axioline F bus base module for housing type H (Replacement item)	AXL F BS H	2700992	5
Zack marker strip for Axioline F (device labeling), in 2 x 20.3 mm pitch, unprinted, 25-section, for individual labeling with B-STIFT 0.8, X-PEN, or CMS-P1-PLOTTER (Marking)	ZB 20,3 AXL UNPRINTED	0829579	25
Zack marker strip, flat, in 10 mm pitch, unprinted, 10-section, for individual labeling with M-PEN 0,8, X-PEN, or CMS-P1-PLOTTER (Marking)	ZBF 10/5,8 AXL UNPRINTED	0829580	50
Documentation	Type	Order No.	Pcs./Pkt.
User manual, English, Axioline F: System and installation	UM EN AXL F SYS INST	-	-
User manual, English, Axioline F: Diagnostic registers, and error messages	UM EN AXL F SYS DIAG	-	-

4 Technical data

Dimensions (nominal sizes in mm)

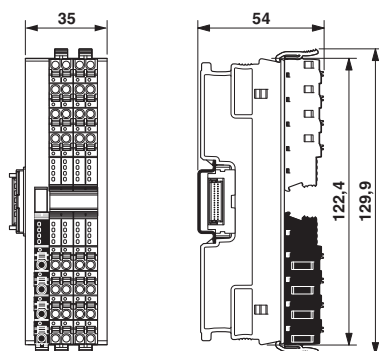

Width	35 mm
Height	129.9 mm
Depth	54 mm
Note on dimensions	The depth is valid when a TH 35-7,5 DIN rail is used (according to EN 60715).

General data

Color	traffic grey A RAL 7042
Weight	159 g (with connectors and bus base module)
Ambient temperature (operation)	-25 °C ... 60 °C
Ambient temperature (storage/transport)	-40 °C ... 85 °C
Permissible humidity (operation)	5 % ... 95 % (non-condensing)
Permissible humidity (storage/transport)	5 % ... 95 % (non-condensing)
Air pressure (operation)	70 kPa ... 106 kPa (up to 3000 m above sea level)
Air pressure (storage/transport)	70 kPa ... 106 kPa (up to 3000 m above sea level)
Degree of protection	IP20
Protection class	III, IEC 61140, EN 61140, VDE 0140-1
Mounting position	any (no temperature derating)

Connection data: Axioline F connector

Connection method	Push-in connection
Conductor cross section solid / stranded	0.2 mm ² ... 1.5 mm ² / 0.2 mm ² ... 1.5 mm ²
Conductor cross section [AWG]	24 ... 16
Stripping length	8 mm



Please observe the information provided on conductor cross sections in the "Axioline F: system and installation" user manual.

Interface: Axioline F local bus

Number	2
Connection method	Bus base module
Transmission speed	100 Mbps

Axioline F local bus supply (U_{Bus})

Supply voltage	5 V DC (via bus base module)
Current draw	max. 120 mA (up to HW 01) max. 60 mA (as of HW 02)
Power consumption	max. 600 mW (up to HW 01) max. 300 mW (as of HW 02)

Supply for digital input and output modules (U_{IO})

Supply voltage	24 V DC
Supply voltage range	19.2 V DC ... 30 V DC (including all tolerances, including ripple)
Current draw	typ. 15 mA (without connected peripherals) max. 8 A (provide external protection)
Power consumption	typ. 360 mW (without connected peripherals) max. 240 W (of which 1.25 W internal losses)
Surge protection of the supply voltage	electronic (35 V, 0.5 s)
Polarity reversal protection of the supply voltage	parallel diode; with external 5 A fuse (only for commissioning)

Supply for digital input and output modules (U_{IO})

Protection

max. 8 A (polarity reversal protection up to 5 A)

**NOTE: Damage to the electronics**

Provide external protection for the module to protect it against polarity reversal. If you are using an external fuse, the power supply unit must be able to supply four times the nominal current of the fuse. This ensures that it trips in the event of an error.



When using the module for the first time, protect it with a 5 A fuse. When all modules in the system are correctly connected, the 5 A fuse can be replaced with an 8 A fuse. After that, you can load the module up to 8 A. Loads over 8 A are not permitted.

Digital inputs

Number of inputs	16
Connection method	Push-in connection
Connection technology	1-wire
Description of the input	EN 61131-2 types 1 and 3
Nominal input voltage	24 V DC
Nominal input current	2.4 mA
Current flow	linear until nominal current is reached, then constantly approx. 2.4 mA
Input voltage range "0" signal	-3 V DC ... 5 V DC
Input voltage range "1" signal	11 V DC ... 30 V DC
Input filter time	3000 µs (default), 1000 µs, < 100 µs
Process data update	< 100 µs
Polarity reversal protection of the inputs	parallel diode (30 V, 5 s)

Digital outputs

Number of outputs	16
Connection method	Push-in connection
Connection technology	1-wire
Nominal output voltage	24 V DC
Maximum output current per channel	500 mA
Maximum output current per device	8 A (provide external protection)
Nominal load, ohmic	max. 12 W (48 Ω, with nominal voltage)
Nominal load, inductive	max. 12 VA (1.2 H, 48 Ω, with nominal voltage)
Nominal load, lamp	max. 12 W (at nominal voltage)
Signal delay	max. 100 µs (when switched on) max. 100 µs (when switched off; with at least 50 mA load current)
Switching frequency	max. 10000 per second (with at least 50 mA load current) max. 1 per second (with inductive load) max. 16 per second (with nominal lamp load)
Load min.	10 kΩ
Energy consumption	see diagram
Limitation of the voltage induced on circuit interruption	-25.8 V ... -15 V
Output voltage when switched off	max. 1 V
Output current when switched off	max. 300 µA

Digital outputs

Behavior with overload	Shutdown with automatic restart
Behavior with inductive overload	Output can be destroyed
Reverse voltage resistance to short pulses	limited protection up to 0.5 A for 1 s

**NOTE: Damage to the electronics**

If there is a faulty external voltage (reverse voltage) at one of the outputs, the output may be destroyed. This may cause unintentional setting of further outputs.

Overcurrent shut-down	as of 0.7 A
Output current with ground connection interrupt when switched off	< 1 mA
Short-circuit protection, overload protection of the outputs	electronic

Input and output address area

Input address area	2 Byte
Output address area	2 Byte

Configuration and parameter data in a PROFIBUS system

Required parameter data	10 Byte
Required configuration data	7 Byte

Electrical isolation/isolation of the voltage areas

Test section	Test voltage
5 V communications power (logic), 24 V supply (I/O)	500 V AC, 50 Hz, 1 min.
5 V supply (logic)/functional earth ground	500 V AC, 50 Hz, 1 min.
24 V supply (I/O) / functional earth ground	500 V AC, 50 Hz, 1 min.

Mechanical tests

Vibration resistance in acc. with EN 60068-2-6/ IEC 60068-2-6	5g
Shock in acc. with EN 60068-2-27/IEC 60068-2-27	30g
Continuous shock according to EN 60068-2-27/ IEC 60068-2-27	10g

Conformance with EMC Directive 2014/30/EU**Noise immunity test in accordance with EN 61000-6-2**

Electrostatic discharge (ESD) EN 61000-4-2/ IEC 61000-4-2	Criterion B, 6 kV contact discharge, 8 kV air discharge
Electromagnetic fields EN 61000-4-3/IEC 61000-4-3	Criterion A, Field intensity: 10 V/m
Fast transients (burst) EN 61000-4-4/IEC 61000-4-4	Criterion B, 2 kV
Transient overvoltage (surge) EN 61000-4-5/ IEC 61000-4-5	Criterion B, DC supply lines: ± 0.5 kV/ ± 0.5 kV (symmetrical/ asymmetrical)
Conducted interference EN 61000-4-6/IEC 61000-4-6	Criterion A; Test voltage 10 V

Noise emission test according to EN 61000-6-3 Class B

Approvals

For the latest approvals, please visit phoenixcontact.net/products.

5 Maximum outputs power consumption when inductive loads are switched off



NOTE: Damage to the electronics
 Restrict freewheeling voltage to a maximum of -17 V when using an external freewheeling circuit! The external freewheeling circuit does not function in the case of higher negative voltages.

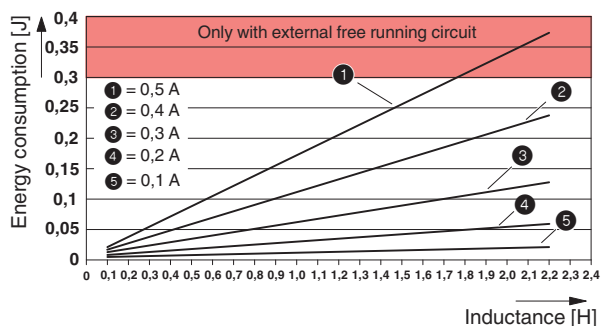

Figure 1 Maximum outputs power consumption when inductive loads are switched off

The specifications in the diagram refer to a maximum switching frequency of 1 Hz.

The diagram shows the maximum amount of energy that may be fed back into the corresponding output groups (outputs 1 to 8, 9 to 16) for each switch-off procedure when switching off an inductive load without external freewheeling circuit.

The current data refers to the ohmic DC voltage component of the inductive load.

6 Internal circuit diagram

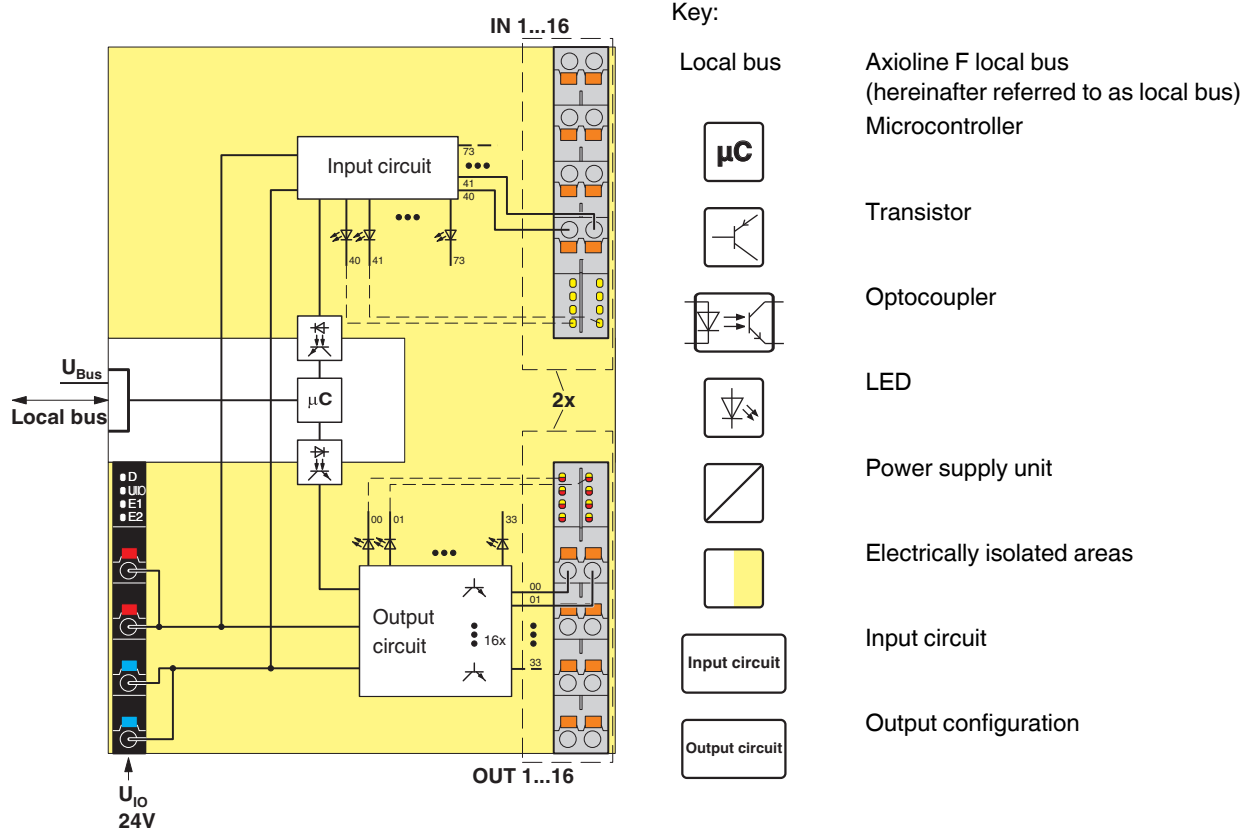

Figure 2 Internal wiring of the terminal points

7 Terminal point assignment

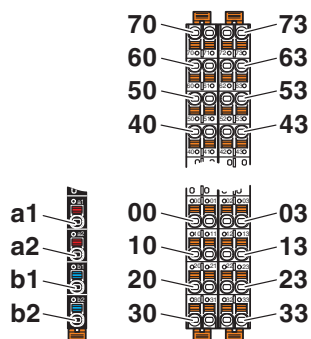

Figure 3 Terminal point assignment

Terminal point	Color	Assignment	
Supply voltage input			
a1, a2	Red	24 V DC (U _{IO})	Supply for digital input and output modules (internally jumpered)
b1, b2	Blue	GND	Reference potential of the supply voltage (bridged internally)
Digital outputs			
00 ... 03	Orange	OUT01 ... OUT04	Digital outputs 1 ... 4
10 ... 13	Orange	OUT05 ... OUT08	Digital outputs 5 ... 8
20 ... 23	Orange	OUT09 ... OUT12	Digital outputs 9 ... 12
30 ... 33	Orange	OUT13 ... OUT16	Digital outputs 13 ... 16
Digital inputs			
40 ... 43	Orange	IN01 ... IN04	Digital inputs 1 ... 4
50 ... 53	Orange	IN05 ... IN08	Digital inputs 5 ... 8
60 ... 63	Orange	IN09 ... IN12	Digital inputs 9 ... 12
70 ... 73	Orange	IN13 ... IN16	Digital inputs 13 ... 16

8 Connection example

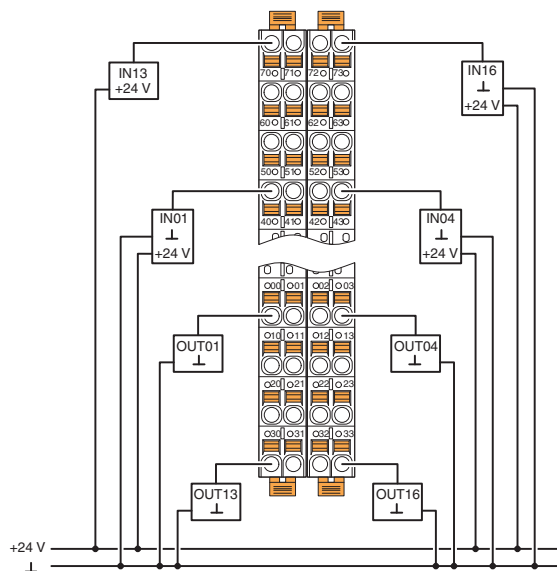
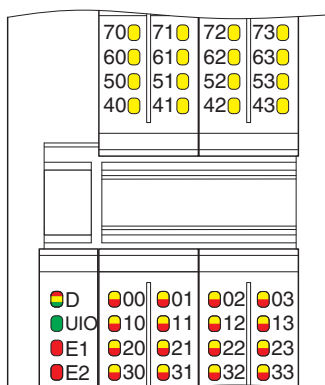

Figure 4 Typical connection of sensors and actuators when using external busbars

Ensure that GND of the sensors and actuators and GND for U_{IO} have the same potential.

9 Local diagnostic and status indicators

As of hardware revision 02



Channel errors are errors that can be associated with a channel.
 Periphery errors are errors that affect the entire module.

Figure 5 Local diagnostic and status indicators

Designation	Color	Meaning	State	Description
D	Red/ yellow/ green	Diagnostics of local bus communication		
		Run	Green on	The device is ready for operation, communication within the station is OK. All data is valid. An error has not occurred.
		Active	Green flashing	The device is ready for operation, communication within the station is OK. The data is not valid. No valid data provided by the controller/higher-level network. There is no error on the module.
		Device application not active	Flashing green/yellow	The device is ready for operation, communication within the station is OK. Output data cannot be outputted and/or input data cannot be read. There is a fault on the periphery side of the module..
		Ready	Yellow on	The device is ready for operation but did not detect a valid cycle after power-up.
		Connected	Yellow flashing	The device is not (yet) part of the active configuration.
		Reset	Red on	The device is ready for operation but has lost the connection to the bus head.
		Not connected	Flashing red	The device is ready for operation but there is no connection to the previously existing device.
		Power down	Off	Device is in (power) reset.
UIO	Green	U _{input/output}	On	Supply for digital input and output modules is present.
			Off	Supply for digital input and output modules is not present.
E1	Red	Peripheral fault	On	I/O error present.
			Off	No I/O error.
E2	Red	Channel error	On	Channel error present.
			Off	Channel error not present.

Designation	Color	Meaning	State	Description
00 ... 03, 10 ... 13, 20 ... 23, 30 ... 33	Red/ yellow	Diagnos- tics / Status of the out- puts	Red on	Short-circuit/overload of the output.
			Yellow on	Output is set.
			Off	No error, output is not set.
40 ... 43, 50 ... 53, 60 ... 63, 70 ... 73	Yellow	Status of the inputs	On	Input is set.
			Off	Input is not set.

Deviating behavior up to hardware revision 01

The LED E2 is not present.

Designation	Color	Meaning	State	Description
E1	Red	Peripheral fault	On	Breakdown or overload/short-circuit of an output.
			Off	No I/O error.

10 Process data

I/O data is mapped in the Motorola format.

OUT process data

Byte	0							
Bit	7	6	5	4	3	2	1	0
Signal	OUT 08	OUT 07	OUT 06	OUT 05	OUT 04	OUT 03	OUT 02	OUT 01
Terminal point	13	12	11	10	03	02	01	00

Byte	1							
Bit	7	6	5	4	3	2	1	0
Signal	OUT 16	OUT 15	OUT 14	OUT 13	OUT 12	OUT 11	OUT 10	OUT 09
Terminal point	33	32	31	30	23	22	21	20

IN process data

Byte	0							
Bit	7	6	5	4	3	2	1	0
Signal	IN08	IN07	IN06	IN05	IN04	IN03	IN02	IN01
Terminal point	53	52	51	50	43	42	41	40

Byte	1							
Bit	7	6	5	4	3	2	1	0
Signal	IN16	IN15	IN14	IN13	IN12	IN11	IN10	IN09
Terminal point	73	72	71	70	63	62	61	60

11 Parameter, diagnostics and information (PDI)

Parameter and diagnostic data as well as other information is transmitted as objects via the PDI channel of the Axioline F station.

The standard and application objects stored in the module are described in the following section.

The following applies to all tables below:

Please refer to the UM EN AXL F SYS INST for an explanation of the data types.

Abbreviation	Meaning
A	Quantity
L	Length of the elements in bytes
R	Read
W	Write



Each visible string is terminated with a null terminator (00_{hex}). The length of a visible-string-type element is therefore at least one byte larger than the number of user data items.
If the number of user data items plus null terminator is smaller than the specified length of the element, the visible string will be populated with a null character (00_{hex}).



For detailed information on PDI objects, please refer to the UM EN AXL F SYS INST user manual.

12 Standard objects

12.1 Objects for identification (device rating plate)

As of hardware revision 02

Index (hex)	Object name	Data type	A	L	Rights	Meaning	Contents
Manufacturer							
0001	VendorName	Visible String	1	32	R	Vendor name	Phoenix Contact
0002	VendorID	Visible String	1	7	R	Vendor ID	00A045
0003	VendorText	Visible String	1	58	R	Vendor text	Components and systems for industrial automation
0012	VendorURL	Visible String	1	58	R	Vendor URL	www.phoenixcontact.com
Module - general							
0004	DeviceFamily	Visible String	1	19	R	Device family	I/O digital IN-OUT
0006	ProductFamily	Visible String	1	32	R	Product family	AXL F
000E	CommProfile	Visible String	1	4	R	Communication profile	633
000F	DeviceProfile	Visible String	1	5	R	Device profile	0010
0011	ProfileVersion	Record of Visible Strings	2	11; 21	R	Profile version	2011-12-07; Basic - Profile V2.0
0017	Language	Record of Visible Strings	2	6; 8	R	Language	en-us; English
Module - special							
0005	Capabilities	Visible String	1	8	R	Capabilities	Nothing
0007	ProductName	Visible String	1	32	R	Product name	AXL F DI16/1 DO16/1 2H
0008	SerialNo	Visible String	1	22	R	Serial number	e. g., 1234512345
0009	ProductText	Visible String	1	58	R	Product text	16 digital inputs, adjustable filter, 16 digital outputs
000A	OrderNumber	Visible String	1	32	R	Order No.	2702106
000B	HardwareVersion	Record of Visible Strings	2	11; 11	R	Hardware version	e. g., 2011-02-04; 00
000C	FirmwareVersion	Record of Visible Strings	2	11; 11	R	Firmware version	e.g., 2017-12-31; 1.00
000D	PChVersion	Record of Visible Strings	2	11; 6	R	PDI version	e. g., 2010-06-21; V1.00
0037	DeviceType	Octet string	1	8	R	Device type	00 C0 00 02 00 00 0D 04 _{hex}
003A	VersionCount	Array of UINT16	4	4 * 2	R	Version counter	e. g., 0007 0001 0001 0001 _{hex}
Use of the device							
0014	Location	Visible String	1	59	R/W	Location	Can be completed by the user.
0015	EquipmentIdent	Visible String	1	59	R/W	Equipment identifier	Can be completed by the user.
0016	ApplDeviceAddr	UINT16	1	2	R/W	Application device address	Can be completed by the user.

Deviating behavior up to hardware revision 01

Index (hex)	Object name	Data type	A	L	Rights	Meaning	Contents
Manufacturer							
0001	VendorName	Visible String	1	16	R	Vendor name	Phoenix Contact
0003	VendorText	Visible String	1	49	R	Vendor text	Components and systems for industrial automation
0012	VendorURL	Visible String	1	23	R	Vendor URL	www.phoenixcontact.com
Module - general							
0006	ProductFamily	Visible String	1	6	R	Product family	AXL F
0011	ProfileVersion	Record of Visible Strings	2	11; 20	R	Profile version	2011-12-07; Basis - Profil V2.0
003A	VersionCount	UINT16	4	4 * 2	R	Version counter	e.g., 0007 0001 0000 0000 _{hex}
Module - special							
0007	ProductName	Visible String	1	23	R	Product name	AXL F DI16/1 DO16/1 2H
0008	SerialNo	Visible String	1	11	R	Serial number	e. g., 1234512345
0009	ProductText	Visible String	1	57	R	Product text	16 digital inputs, adjustable filter, 16 digital outputs
000A	OrderNumber	Visible String	1	8	R	Order No.	2702106
000B	HardwareVersion	Record of Visible Strings	2	11; 3	R	Hardware version	e. g., 2011-02-04; 00
000C	FirmwareVersion	Record of Visible Strings	2	11; 3	R	Firmware version	0000-00-00; --

12.2 Miscellaneous standard objects

Index (hex)	Object name	Data type	A	L	Rights	Meaning/contents	
Diagnostics objects							
0018	DiagState	Record	6	58	R	Diagnostic state	*
Objects for process data management							
0025	PDIN	Octet string	1	2	R	Input process data	*
0026	PDOOUT	Octet string	1	2	R	Output process data	*
003B	PDIN_Descr	Array of Records	3	8; 2; 2	R	Description of the IN process data	
003C	PDOOUT_Descr	Array of Records	3	8; 2; 2	R	Description of the output process data	

The objects marked in the last column with an * are described in more detail in the next sections.

The description of the other objects is to be found in the user manual UM EN AXL F SYS INST.

The objects 003B_{hex} and 003C_{hex} are only applicable to tools.

12.3 Diagnostics objects

Diagnostics state (0018_{hex}: DiagState)

This object is used for a structured message of an error.

As of hardware revision 02

0018 _{hex} : Diagnostics state (read)					
Subindex	Data type	Length in bytes	Meaning	Contents	
0	Record	58	Diagnostic state	Complete diagnostics information	
1	UINT16	2	Error number	0 ... 65535 _{dec}	
2	UINT8	1	Priority	00 _{hex}	No error
				01 _{hex}	Error
				02 _{hex}	Warning
				81 _{hex}	Error removed
				82 _{hex}	Warning eliminated
3	UINT8	1	Channel/group/module	00 _{hex}	No error
				01 _{hex}	Channel 1 (OUT01)
			
				10 _{hex}	Channel 16 (OUT16)
				FF _{hex}	entire device
4	UINT16	2	Error code	See table below	
5	UINT8	1	More follows	00 _{hex}	
6	Visible String	51	Text	See table below	



The message with priority 81_{hex} or 82_{hex} is a one-off, internal message to the bus coupler. The bus coupler transfers this error message to the error mechanisms of the higher-level system.



After all errors have been eliminated, it is automatically reset.

Error and status of the local diagnostics and status indicators

Subindex	2	3	4	6	LED				
	Priority	Channel/group/module	Error code	Text	D	UIO	E1	E2	xx
Error	hex	hex	hex						
No error	00	00	0000	Status OK	●	●	○	○	○
Short-circuit/overload of an output	02	##	2344	Overload / short circuit DO##, terminal point \$\$	●	●	○	●	●
I/O supply failure	01	FF	3400	Missing I/O supply UIO, terminal point a1/a2, b1/b2	✱	○	●	○	○

- ## Channel number
- \$\$ Terminal point number
- Off
- On
- xx LED
- xx 00 ... 03, 10 ... 13, 20 ... 23, 30 ... 33
- Green on
- Red on
- ✱ Flashing green/yellow

Deviating behavior up to hardware revision 01

0018 _{hex} : Diagnostics state (read)				
Subindex	Data type	Length in bytes	Meaning	Contents
0	Record	8	Diagnostic state	Complete diagnostics information
1	UINT16	2	Error number	0 ... 65535 _{dec}
2	UINT8	1	Priority	00 _{hex} No error
				01 _{hex} Error
				02 _{hex} Warning
				81 _{hex} Error removed
				82 _{hex} Warning eliminated
3	UINT8	1	Channel/group/module	00 _{hex} No error
				FF _{hex} entire device
4	UINT16	2	Error code	See table below
5	UINT8	1	More follows	00 _{hex}
6	Visible String	1	Text	00 _{hex}

Error and status of the local diagnostics and status indicators

Subindex	2	3	4	LED			
	Priority	Channel/ group/ module	Error code	D	UIO	E1	xx
Error	hex	hex	hex				
No error	00	00	0000	●	●	○	○
Short-circuit/overload of an output	02	00	2344	●	●	●	●
I/O supply failure	01	FF	3400	⚡	○	○	○

xx LED

Diagnostics of the output

xx

00 ... 03, 10 ... 13, 20 ... 23, 30 ... 33

○

Off

●

Green on

●

On

●

Red on

⚡

Flashing green/yellow

12.4 Objects for process data management

12.4.1 IN process data (0025_{hex}: PDIN)

You can read the IN process data of the module with this object.

The structure corresponds to the representation in the "Process data" section.

0025 _{hex} : IN process data (read)			
Subindex	Data type	Length in bytes	Meaning
0	Octet string	2	Input process data

12.4.2 OUT process data (0026_{hex}: PDOUT)

You can read the OUT process data of the module with this object.

The structure corresponds to the representation in the "Process data" section.

0026 _{hex} : OUT process data (read)			
Subindex	Data type	Length in bytes	Meaning
0	Octet string	2	Output process data

13 Application objects

In the case of valid parameters, the parameterization is stored in the module permanently.

Index (hex)	Object name	Data type	A	L	Rights	Meaning/contents
FF8D	PD Output Substitute Configuration	UINT8	1	1	R/W	Substitute value behavior
FF8F	Input_Filter	UINT8	1	1	R/W	Filter time

13.1 Substitute value behavior (FF8D_{hex}: PD Output Substitute Configuration)

With this object, you parameterize the behavior of the module so that an application reset can be detected if necessary.

FF8D _{hex} : Substitute value behavior (read, write)				
Subindex	Data type	Length in bytes	Contents	
0	UINT8	1	00 _{hex} (Default)	Set outputs to 0
			01 _{hex}	Hold last value

13.2 Filter time (FF8F_{hex}: Input_Filter)

You parameterize the filter time of the module with this object.

FF8F _{hex} : Input_Filter (read, write)				
Subindex	Data type	Length in bytes	Contents	
0	UINT8	1	00 _{hex} (Default)	3000 μs
			01 _{hex}	1000 μs
			02 _{hex}	< 100 μs

14 Device descriptions

The device is described in the device description files.

The device descriptions for controllers from Phoenix Contact are included in PC Worx and the corresponding service packs.

The device description files for other systems are available for download at phoenixcontact.net/products in the download area of the bus coupler used.



SCATTERGOOD & JOHNSON LTD

ELECTRICAL ENGINEERING & FLUID CONTROL DISTRIBUTORS

Est.1899

At Scattergood & Johnson Ltd, we pride ourselves on being a technical distributor to specialist industries.

Working with a range of quality product suppliers across a number of specialist markets, we are not your average 'box shifter' - we are your technical and supply chain partner.

We fully support every product we sell - for free! Our internal team and external sales engineers can answer any product or application question, no matter the complexity.

Backing up this technical ability is a range of 50,000+ products available from stock for nationwide next day delivery (same day if required!), or you can collect what you need from any of our trade counters around the UK.

Select your specialist interest below to learn more about how we can help.



Online, In Branch and On the Road - Scattergood & Johnson Ltd, there when you need us.

www.scatts.co.uk