



Axioline F safety module with safe digital inputs

User manual

User manual

Axioline F safety module with safe digital inputs

2016-11-10

Designation: UM EN AXL F SSDI8/4 1F

Revision: 01

This user manual is valid for:

| Designation | From HW/FW revision | Order No. |
|------------------|------------------------|-----------|
| AXL F SSDI8/4 1F | 01/220 | 2702263 |

Please observe the following notes

User group of this manual

The use of products described in this manual is oriented exclusively to:

- Qualified electricians or persons instructed by them, who are familiar with applicable standards and other regulations regarding electrical engineering and, in particular, the relevant safety concepts.
- Qualified application programmers and software engineers, who are familiar with the safety concepts of automation technology and applicable standards.

Explanation of symbols used and signal words



This is the safety alert symbol. It is used to alert you to potential personal injury hazards. Obey all safety measures that follow this symbol to avoid possible injury or death.

There are three different categories of personal injury that are indicated with a signal word.

DANGER This indicates a hazardous situation which, if not avoided, will result in death or serious injury.

WARNING This indicates a hazardous situation which, if not avoided, could result in death or serious injury.

CAUTION This indicates a hazardous situation which, if not avoided, could result in minor or moderate injury.



This symbol together with the signal word **NOTE** and the accompanying text alert the reader to a situation which may cause damage or malfunction to the device, hardware/software, or surrounding property.



This symbol and the accompanying text provide the reader with additional information or refer to detailed sources of information.

How to contact us

Internet

Up-to-date information on Phoenix Contact products and our Terms and Conditions can be found on the Internet at:

phoenixcontact.com

Make sure you always use the latest documentation.

It can be downloaded at:

phoenixcontact.net/products

Subsidiaries

If there are any problems that cannot be solved using the documentation, please contact your Phoenix Contact subsidiary.

Subsidiary contact information is available at phoenixcontact.com.

Published by

PHOENIX CONTACT GmbH & Co. KG
 Flachsmarktstraße 8
 32825 Blomberg
 GERMANY

Should you have any suggestions or recommendations for improvement of the contents and layout of our manuals, please send your comments to:

tecdoc@phoenixcontact.com

Please observe the following notes

General terms and conditions of use for technical documentation

Phoenix Contact reserves the right to alter, correct, and/or improve the technical documentation and the products described in the technical documentation at its own discretion and without giving prior notice, insofar as this is reasonable for the user. The same applies to any technical changes that serve the purpose of technical progress.

The receipt of technical documentation (in particular user documentation) does not constitute any further duty on the part of Phoenix Contact to furnish information on modifications to products and/or technical documentation. You are responsible to verify the suitability and intended use of the products in your specific application, in particular with regard to observing the applicable standards and regulations. All information made available in the technical data is supplied without any accompanying guarantee, whether expressly mentioned, implied or tacitly assumed.

In general, the provisions of the current standard Terms and Conditions of Phoenix Contact apply exclusively, in particular as concerns any warranty liability.

This manual, including all illustrations contained herein, is copyright protected. Any changes to the contents or the publication of extracts of this document is prohibited.

Phoenix Contact reserves the right to register its own intellectual property rights for the product identifications of Phoenix Contact products that are used here. Registration of such intellectual property rights by third parties is prohibited.

Other product identifications may be afforded legal protection, even where they may not be indicated as such.

Table of contents

| | | |
|----------|--|-----------|
| 1 | For your safety | 9 |
| 1.1 | General safety notes..... | 9 |
| 1.2 | Electrical safety | 10 |
| 1.3 | Safety of the machine or system..... | 11 |
| 1.4 | Directives and standards | 11 |
| 1.5 | Intended use | 11 |
| 1.6 | Documentation | 12 |
| 1.7 | Abbreviations used | 12 |
| 1.8 | Safety hotline..... | 12 |
| 2 | Product description..... | 13 |
| 2.1 | Short description of the module | 13 |
| 2.2 | Structure of the module | 14 |
| 2.3 | Housing dimensions | 14 |
| 2.4 | Safe digital inputs | 15 |
| 2.5 | Clock outputs T1 and T2..... | 16 |
| 2.6 | Connection options for sensors depending on the parameterization | 18 |
| 2.7 | Local diagnostics and status indicators | 19 |
| 2.8 | Safe state | 21 |
| 2.8.1 | Operating state | 21 |
| 2.8.2 | Error detection in I/O devices | 21 |
| 2.8.3 | Device errors | 22 |
| 2.8.4 | Parameterization errors | 22 |
| 2.9 | Process data words | 23 |
| 2.10 | Programming data/configuration data..... | 23 |
| 3 | Integration of the Axioline F local bus | 25 |
| 3.1 | Supply voltage of the module logic | 25 |
| 3.2 | Supply voltage U_1 | 25 |
| 3.3 | DC distribution network according to IEC 61326-3-1 | 26 |
| 3.4 | Terminal point assignment..... | 27 |

AXL F SSDI8/4 1F

| | | |
|----------|--|-----------|
| 4 | Assembly, removal, and electrical installation | 29 |
| 4.1 | Assembly and removal | 29 |
| 4.1.1 | Unpacking the module | 29 |
| 4.1.2 | Preparation and assembly | 29 |
| 4.1.3 | Setting the DIP switch | 30 |
| 4.1.4 | Mounting and removing modules | 31 |
| 4.2 | Electrical installation | 33 |
| 4.2.1 | Electrical installation of the Axioline F station | 33 |
| 4.2.2 | Electrical installation of the module | 33 |
| 5 | Parameterization of the module | 35 |
| 5.1 | Parameterization in a SafetyBridge system | 35 |
| 5.2 | Parameterization of the safe inputs..... | 36 |
| 6 | Duration of a safety demand | 39 |
| 7 | Connection examples for safe inputs | 41 |
| 7.1 | Explanation of the examples..... | 41 |
| 7.2 | Measures to achieve a specific safety integrity..... | 42 |
| 7.3 | Single-channel assignment of safe inputs | 44 |
| 7.3.1 | Notes | 44 |
| 7.3.2 | Cross-circuit monitoring enabled | 44 |
| 7.3.3 | Cross-circuit monitoring disabled, supply through T1 | 46 |
| 7.3.4 | Supply through OSSD | 48 |
| 7.4 | Two-channel equivalent assignment of safe inputs | 50 |
| 7.4.1 | Notes on errors | 52 |
| 7.4.2 | Cross-circuit monitoring enabled, supply through T1 and T2 | 53 |
| 7.4.3 | Cross-circuit monitoring disabled, supply through a clock output or external supply | 55 |
| 7.4.4 | External supply (OSSD) | 58 |
| 7.5 | Two-channel non-equivalent assignment of safe inputs | 60 |
| 7.5.1 | Notes on errors | 62 |
| 7.5.2 | Cross-circuit monitoring enabled, supply through T1 and T2 | 63 |
| 7.5.3 | Cross-circuit monitoring disabled, supply through a clock output or external supply | 64 |

Table of contents

| | | |
|-----------|---|-----------|
| 8 | Startup and validation | 67 |
| | 8.1 Initial startup | 67 |
| | 8.1.1 Startup mode | 68 |
| | 8.2 Restart after replacing a module | 69 |
| | 8.2.1 Replacing a module | 69 |
| | 8.2.2 Restart | 69 |
| | 8.3 Validation..... | 69 |
| 9 | Errors: messages and removal | 71 |
| | 9.1 Displaying and reading errors | 71 |
| | 9.2 Acknowledging an error | 71 |
| | 9.3 Module replacement following an error..... | 71 |
| | 9.4 Note about the error codes | 72 |
| | 9.5 Error codes..... | 73 |
| 10 | Maintenance, repair, decommissioning, and disposal | 77 |
| | 10.1 Maintenance..... | 77 |
| | 10.2 Repair..... | 77 |
| | 10.3 Decommissioning and disposal..... | 77 |
| 11 | Technical data and ordering data | 79 |
| | 11.1 SafetyBridge system data..... | 79 |
| | 11.2 AXL F SSDI8/4 1F module data..... | 79 |
| | 11.3 Conformance with EMC Directive..... | 83 |
| | 11.4 Ordering data: module..... | 83 |
| | 11.5 Download data: software | 83 |
| | 11.6 Download data: documentation..... | 84 |
| A | Appendix: checklists..... | 85 |
| | A 1 Planning | 86 |
| | A 2 Assembly and electrical installation | 87 |
| | A 3 Startup and parameterization | 88 |
| | A 4 Validation | 89 |
| B | Appendix: index..... | 91 |
| C | Appendix: revision history..... | 93 |

AXL F SSDI8/4 1F

1 For your safety

Purpose of this user manual

This user manual provides information about how the module works, its operating and connection elements, and its parameter settings.

Validity of the user manual

This user manual is valid for the AXL F SSDI8/4 1F module in the version indicated on the inner cover page, as well as for the same or later versions if replaced with devices of the same type.

1.1 General safety notes



WARNING: Risk of injury

Depending on the application, inappropriate use of the module may result in serious injury.

- Observe all the safety notes and warning instructions provided in this section and elsewhere in this user manual.

Qualified personnel

In terms of this user manual, qualified personnel are persons who, because of their education, experience and instruction, and their knowledge of relevant standards, regulations, accident prevention, and service conditions, have been authorized to carry out any required operations, and who are able to recognize and avoid any possible dangers.

Furthermore, knowledge of the following topics and products is required:

- Non-safety-related target system (e.g., PROFIBUS, PROFINET, EtherCAT®)
- SafetyBridge system
- Components used
- Axioline F product range
- Operation of the software tools
- Safety regulations in the field of application

In the context of the use of the system, the following operations must only be carried out by qualified personnel:

- Planning
- Configuration, parameterization, programming
- Installation, startup, servicing
- Maintenance, decommissioning

Documentation

Observe all information in this user manual and the accompanying documents: see Section 1.6 “Documentation” on page 12.

Safety of personnel and equipment

The safety of personnel and equipment can only be assured if the module is used correctly: see Section 1.5 “Intended use” on page 11.

Error detection

Depending on the wiring and the parameterization, the module detects errors within the safety equipment.

AXL F SSDI8/4 1F**Do not carry out any repairs or modifications**

It is prohibited for the user to carry out repair work or make modifications to the module. The housing must not be opened. The module is protected against tampering by means of security labels. The security label is damaged in the event of unauthorized repairs or opening of the housing. In this case, the correct operation of the safety module can no longer be ensured.

In the event of an error, send the module to Phoenix Contact or contact Phoenix Contact immediately and engage a service engineer.

Mismatching and polarity reversal of connections

Take care to avoid the mismatching, polarity reversal or tampering of connections. For increased protection against mismatching, connectors and slot markings are color coded.

1.2 Electrical safety

**WARNING: Loss of safety function/hazardous shock currents**

Incorrect installation can result in the loss of the safety function as well as hazardous shock currents.

- Observe the notes on electrical safety.
- Plan the modules used and their installation in the system according to the specific requirements.
- Recheck plants and systems retrofitted with SafetyBridge.

Direct/indirect contact

Protection against direct and indirect contact according to VDE 0100 Part 410 must be ensured for all components connected to the system. In the event of an error, parasitic voltages must not occur (single-fault tolerance).

Measures required:

- Using power supply units with safe isolation (PELV).
- Decoupling circuits, which are not PELV systems, using optocouplers, relays, and other components which meet the requirements of safe isolation.

Power supply units for 24 V supply

Only use power supply units with safe isolation and PELV according to EN 50178/VDE 0160 (PELV). These power supply units prevent short circuits between the primary and secondary side.

Make sure that the output voltage of the power supply does not exceed 32 V even in the event of an error.

Insulation rating

When selecting the equipment, please take into consideration the dirt and surge voltages which may occur during operation.

The module is designed for overvoltage category II (according to DIN EN 60664-1). If you expect surge voltages in the system, which exceed the values defined in overvoltage category II, implement additional measures for voltage limitation.

1.3 Safety of the machine or system

The machine/system manufacturer and the operator are responsible for the safety of the machine or system and the application in which the machine or system is used.

Draw up and implement a safety concept

In order to use the module, a safety concept is required for your machine or system. This includes a hazard and risk analysis as well as a test report (checklist) for validating the safety function: see Section 1.4 “Directives and standards” on page 11 and see Section A “Appendix: checklists” on page 85.

The target safety integrity (SIL according to IEC 61508, SILCL according to EN 62061 or performance level and category according to EN ISO 13849-1) is ascertained on the basis of the risk analysis. The safety integrity ascertained determines how to connect and parameterize the module within the safety function.

Validate hardware and parameterization

Carry out a validation every time you make a safety-related modification to your overall system.

Use your test report to ensure that:

- The safe modules are connected to the correct sensors and actuators
- The safe input and output channels have been parameterized correctly
- The variables have been linked to the safe sensors and actuators (single-channel or two-channel) correctly

1.4 Directives and standards

The standards to which the module conforms are listed in the certificate issued by the approval body and in the EC declaration of conformity (see: phoenixcontact.net/products).

1.5 Intended use

The AXL F SSDI8/4 1F module is designed exclusively for use in a SafetyBridge system. It can only perform its tasks in the system if it is used according to the specifications in this document.

Only use the module according to the defined technical data and ambient conditions: see Section 11 “Technical data and ordering data” on page 79.

The module is designed for connecting single-channel or two-channel sensors, which can be used in association with safety technology.

Examples of use for the module:

- Single or two-channel emergency stop equipment or safety door equipment
- Applications with enable button
- Applications with two-hand control devices
- Applications with mode selector switches
- As secondary switchgear for safety-related photoelectric barriers
- Safety circuits according to EN 60204, Part 1

1.6 Documentation

Currentness and availability of documentation

Always use the latest documentation. Changes or additions to documentation can be found on the Internet (see: phoenixcontact.net/products).

SafetyBridge user manuals

User manuals:

- For the controller used
- For the logic module of the SafetyBridge system
- For the SafetyBridge system I/O modules used
- For the SafetyBridge system function blocks

Please also observe the information on the bus system used.

Documentation for the Axioline F product range

Axioline F: system and installation user manual, UM EN AXL F SYS INST

Documentation for the bus coupler used

1.7 Abbreviations used

Table 1-1 Abbreviations for safety requirements

| Abbreviation | Meaning | Standard | Example |
|--------------|------------------------|----------------|----------------|
| SIL | Safety integrity level | IEC 61508 | SIL 2, SIL 3 |
| SILCL | SIL claim limit | EN 62061 | SILCL 3 |
| Cat. | Category | EN ISO 13849-1 | Cat. 2, Cat. 4 |
| PL | Performance level | EN ISO 13849-1 | PL e, PL d |

Table 1-2 General abbreviations

| Abbreviation | Meaning |
|--------------|---|
| PELV | Protective extra-low voltage according to EN 50178/VDE 0160 |
| EUC | Equipment under control |

1.8 Safety hotline

Should you have any technical questions, please contact our 24-hour hotline.

Phone: + 49 5281 9-46277, e-mail: safety-service@phoenixcontact.com

2 Product description

2.1 Short description of the module

The AXL F SSDI8/4 1F module is an input module for use at any point in an Axioline F station.

The module is designed for use in the SafetyBridge system. The SafetyBridge address is set via a DIP switch.

The module has four safe digital inputs for two-channel assignment or eight safe digital inputs for single-channel assignment.

The inputs can be parameterized according to the specific application and enable the integration of sensors in the safe SafetyBridge system.

In the SafetyBridge system, the module can be used to achieve safety functions with the following requirements depending on the operating conditions:

- Up to SIL 3 according to IEC 61508
- Up to SILCL 3 according to EN 62061
- Up to Cat. 4/PL e according to EN ISO 13849-1

2.2 Structure of the module

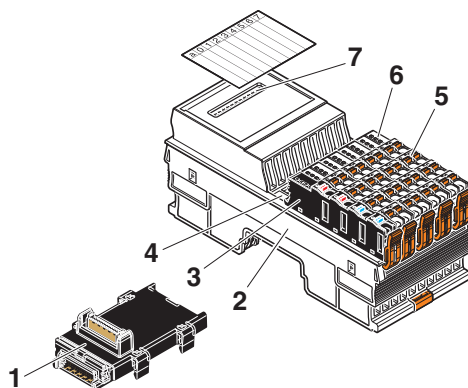


Figure 2-1 Structure of the module

- 1 Bus base module
- 2 Electronics module
- 3 Connector for connecting the supply voltage
- 4 Function identification
- 5 I/O connector
- 6 Diagnostics and status indicators
- 7 DIP switch



More detailed information on setting the switch: see Section 4.1.3 “Setting the DIP switch” on page 30.

2.3 Housing dimensions

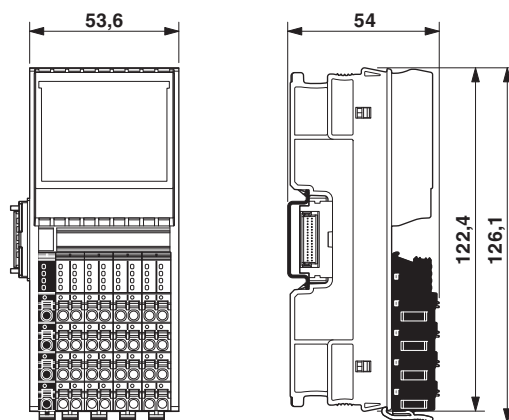


Figure 2-2 Housing dimensions (in mm)

2.4 Safe digital inputs

The module has safe digital inputs which can be used as follows:

- For two-channel assignment: four two-channel inputs
- For single-channel assignment: eight single-channel inputs

Technical data for the safe inputs: see “Safe digital inputs” on page 81. The supply voltage for the inputs can be provided externally or via the clock outputs.

Parameterization

The safe digital inputs of the module can be parameterized in pairs. This means that the inputs can be adapted to various operating conditions and different safety integrity levels can be implemented (SIL, SILCL, Cat., PL).



The safety integrity (SIL, SILCL, Cat., PL) and error detection that can be achieved depend on the parameterization, the structure of the sensor, and the cable installation: see Section 7 “Connection examples for safe inputs” on page 41.

Information on the parameterization of the inputs: see Section 5.2 “Parameterization of the safe inputs” on page 36.

Diagnostics

Diagnostics are provided via both the local diagnostics indicators and the diagnostic messages which are transmitted to the logic module.

Information on the diagnostic messages of the inputs: see Section 9 “Errors: messages and removal” on page 71.



WARNING: Loss of safety function

Using diagnostic data for safety-related functions can result in the loss of the safety function as diagnostic data is not safety-related.

- Do not use the diagnostic data for safety-related functions or actions.

Requirements for sensors/controlling devices

Functional safety places requirements on the design of sensors/controlling devices.

- Use suitable sensors/controlling devices which are described in the applicable safety standards, for example.

The module's ability to detect errors depends on the parameterization.

- Adapt the module parameterization to the relevant sensor/controlling device: see Section 5 “Parameterization of the module” on page 35.

2.5 Clock outputs T1 and T2

The module has two independent clock outputs. These clock outputs provide the supply voltage for the safe inputs. Both clock outputs provide a pulse pattern to detect cross-circuits in the external wiring of the inputs if cross-circuit monitoring has been activated for at least one input pair.

Typical pulse pattern

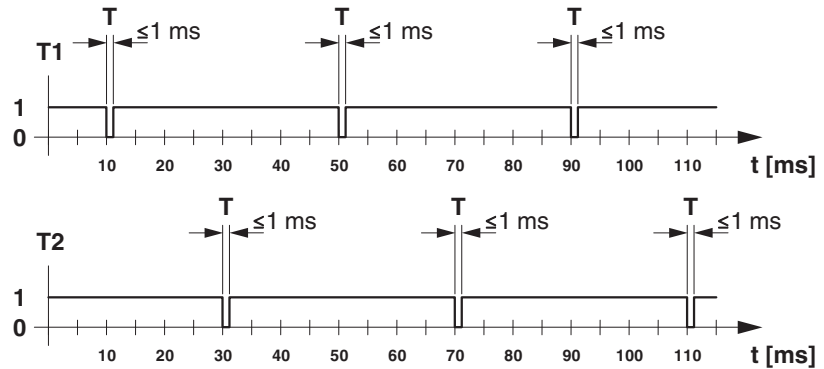


Figure 2-3 Typical pulse pattern

Key:

- T Test pulse
- Pulse width ≤ 1 ms
- Period length ≤ 40 ms



The clock outputs are also switched on and monitored when the module is not parameterized. If a short circuit occurs at a clock output when it is in this state, the clock output is switched off.

Technical data for the clock outputs: see "Clock outputs" on page 82.

Behavior in the event of an error

In the event of short circuit to GND or overload of the clock outputs, the clock outputs are switched off. A diagnostic message is generated and the message is indicated via the SD LED. This error must be acknowledged so that the system can be started up again following error removal, see "Errors: messages and removal" on page 71.

As there are two clock outputs for eight inputs, there may be reciprocal effects between the inputs.

Diagnostics

**WARNING: Loss of safety function**

Using diagnostic data for safety-related functions can result in the loss of the safety function as diagnostic data is not safety-related.

- Do not use the diagnostic data for safety-related functions or actions.

Diagnostics are provided via both the local diagnostics indicators and the diagnostic messages which are transmitted to the logic module.

Information on the diagnostic messages: see Section 9 “Errors: messages and removal” on page 71.

Cross-circuit monitoring

If all inputs are parameterized without cross-circuit monitoring, a DC voltage can be tapped at the clock outputs without clock pulses. As soon as cross-circuit monitoring has been parameterized for at least one input pair, pulses are output at clock outputs T1 and T2.

For inputs that are parameterized with cross-circuit monitoring, the assignment is as follows:

- Inputs for channel 1 (INx_CH1) are assigned to clock output T1.
- Inputs for channel 2 (INx_CH2) are assigned to clock output T2.

Observe the information on error detection according to clocking: see Section 2.5 “Clock outputs T1 and T2” on page 16.

2.6 Connection options for sensors depending on the parameterization

Sensors that meet various safety requirements depending on the parameterization can be connected to the inputs.

The maximum achievable SIL/SILCL/Cat./PL is specified in the table.

In order to meet the safety requirements:

- Observe the information in the connection examples: see Section 7 “Connection examples for safe inputs” on page 41.
- Observe the requirements of the standards with regard to the external wiring and the sensors to be used to achieve a SIL/SILCL/Cat./PL: see Section 7.2 “Measures to achieve a specific safety integrity” on page 42.

| Connection to the Axioline F connectors | | Input | | | | | | | |
|---|-------|---|---------|-----|---|---------|-----|----------------|---------|
| | | Single-channel sensor or redundant sensor | | | Two-channel redundant controlling device/sensor | | | | |
| Input signal | | | | | Equivalent | | | Non-equivalent | |
| Cross-circuit monitoring | | With | Without | | With | Without | | With | Without |
| Sensors that can be connected: | | | | | | | | | |
| – Contact-based | | Yes | Yes | - | Yes | Yes | - | Yes | Yes |
| – With OSSD outputs | | No | - | Yes | No | - | Yes | No | No |
| Achievable safety integrity | SIL | 2 | 2 | 2 | 3 | 3 | 3 | 3 | 3 |
| | SILCL | 2 | 2 | 2 | 3 | 3 | 3 | 3 | 3 |
| | Cat. | 3* | 2 | 2 | 4 | 3 | 4** | 4 | 3 |
| | PL | d | d | d | e | d | e | e | d |
| For connection example, see page | | 44 | 46 | 48 | 53 | 55 | 58 | 63 | 64 |

* Cat. 3 can only be achieved with a redundant sensor.

** The category that can be achieved depends on the sensor used.

2.7 Local diagnostics and status indicators

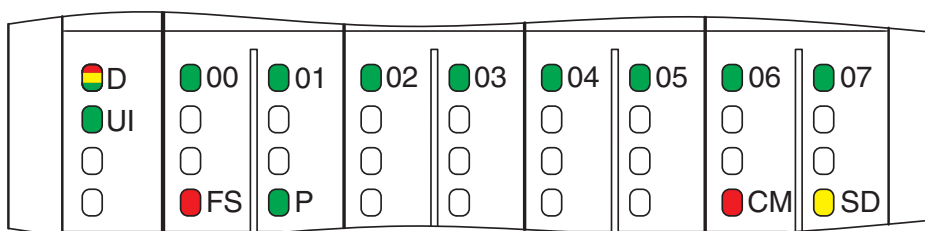



Figure 2-4 Local diagnostics and status indicators

Table 2-1 Overview of diagnostics LEDs

| Des. | Color | State | Description |
|------|----------------------|--|--|
| D | Red/yellow/ green | Diagnostics for local bus communication | |
| | | Green on | The device is ready for operation, communication within the station is OK. All data is valid. There is no error. |
| | | Flashing green | The device is ready for operation, communication within the station is OK. The data is not valid. Valid data from the controller/higher-level network not available. There is no error on the module. |
| | | Flashing green/yellow | The device is ready for operation, communication within the station is OK. Output data cannot be output and/or input data cannot be read. There is an error on the I/O side of the module. |
| | | Yellow on | The device is ready for operation, but has still not detected a valid cycle after power on. |
| | | Flashing yellow | The device is not (yet) part of the active configuration. |
| | | Red on | The device is ready for operation, but has lost the connection to the bus head. |
| | | Flashing red | The device is ready for operation, but there is no connection to the previous device. |
| | | Off | Device is in (power) reset. |
| UI | Green | Diagnostics for digital input supply | |
| | | Green on | Supply for the digital inputs is present and is > around 17 V DC. |
| | | Flashing green | Supply for the digital inputs is not present or is < around 17 V DC. |
| FS | Red | Diagnostics for failure state | |
| | | Off | The safety application has a valid parameterization. (Only applies if UI is on or flashing at the same time.) |
| | | Red on | Hardware fault. Communication to the higher-level controller is disabled. The module has entered the safe state (failure state). |
| | | Flashing red | The module is not parameterized. |

AXL F SSDI8/4 1F

Table 2-1 Overview of diagnostics LEDs [...]

| Des. | Color | State | Description |
|---------|--------|--|---|
| P | Green | Diagnostics for safe communication protocol | |
| | | Off | No safe communication. |
| | | Green on | Safe communication is running without errors. |
| | | Flashing green | Safe communication is running. The SafetyBridge system is requesting an acknowledgment. |
| CM | Red | Startup mode | |
| | | Off | SafetyBridge mode. |
| | | Red on | Startup mode.  WARNING: In startup mode, the device is in standard operation. Startup mode: see Section 8.1.1 "Startup mode" on page 68. |
| SD | Yellow | Acknowledgment request | |
| | | Off | No diagnostic message present that needs to be acknowledged. |
| | | Yellow on | A diagnostic message is present that needs to be acknowledged for safe digital input errors, supply voltage errors or general errors. Acknowledgment: see Section 9.2 "Acknowledging an error" on page 71. |
| 00 - 07 | Green | Status of each input from 0 - 7 | |
| | | Off | Input at logic "0". |
| | | Green on | Input at logic "1". |

2.8 Safe state

The safe state for the module is the transmission of the value “0” in the image of the inputs to the logic module.

The safe state can be entered in the following cases:

1. Operating state
2. Error detection in I/O devices
3. Device errors
4. Parameterization errors
5. Error detection during safe communication

2.8.1 Operating state

In the operating state, the inputs can enter states “1” or “0”. State “0” is the safe state.

2.8.2 Error detection in I/O devices

Inputs

If an error is detected at an input, the safe state is set at this input and a “0” is represented in the process image of the input (“0” = safe state).

Operating time in the error state



WARNING: Loss of the safe state in the failure state

In the failure state, internal module tests are no longer run and it is possible that the safe state may be exited due to an accumulation of errors.

- If the module enters an error state, assess, acknowledge or remove the error within 72 hours.

Depending on the parameterization, the following errors can be detected at inputs:

- Short circuit
- Cross-circuit
- Overload/short circuit of the clock outputs

The diagnostic message is transmitted to the logic module: see Section 9 “Errors: messages and removal” on page 71. Information on which errors occur and when: see Section 7 “Connection examples for safe inputs” on page 41.

2.8.3 Device errors

Device errors can stop safe communication.

Inputs

If a hardware fault in the internal circuit is detected at an input, **all** module inputs enter the safe state. The value “0” is represented in the process image of the inputs (“0” = safe state).

The diagnostic message is transmitted to the logic module: see Section 9 “Errors: messages and removal” on page 71.

Failure state: serious errors

Serious errors that can result in the loss of or adversely affect the safety function cause the entire module to enter the safe state. The FS LED on the module is permanently on. The failure state can only be exited by means of a power up.

The following serious errors result in the safe state:

- Serious hardware faults in the internal circuit
- User errors
- Module overload
- Module overheating
- Incorrect supply

The diagnostic message is transmitted to the logic module: see Section 9 “Errors: messages and removal” on page 71.



WARNING: Loss of safety function

Sequential errors can result in the loss of the safety function.

- In the event of a device error, the module should be completely disconnected from the power supply and replaced so as to prevent sequential errors.

2.8.4 Parameterization errors

The module switches to the safe state following parameterization errors. The FS LED on the module flashes.

In the event of faulty parameterization, a diagnostic message is transmitted to the logic module: see Section 9 “Errors: messages and removal” on page 71.

2.9 Process data words

The module occupies four words in the Axioline F system.



Access the process data words via the “Operate” function block.

2.10 Programming data/configuration data

Phoenix Contact provides device description files for various control systems.



The programming data/configuration data is defined in the device description (FDCML, GSD, GSDML, etc.) according to the bus or network used.

AXL F SSDI8/4 1F

3 Integration of the Axioline F local bus

The module is integrated for operation in an Axioline F station.



More detailed information on the structure of an Axioline F station: see UM EN AXL F SYS INST user manual.

3.1 Supply voltage of the module logic

The supply voltage for the module logic is generated in the bus coupler and led to the Axioline F module via the bus base module.



WARNING: Loss of safety function

The use of unsuitable power supplies can result in the loss of the safety function.

- Only use power supplies according to EN 50178/VDE 0160 (PELV) for the voltage supply at the bus coupler.
- Observe the general safety notes: see Section 1.2 “Electrical safety” on page 10.

Technical data for the supply voltage: see Section “Supply voltage U_{BUS} (logic)” on page 81.

The current carrying capacity for supply voltage U_{BUS} depends on the bus coupler used.

- Observe the technical data and information in the documentation for the bus coupler.

3.2 Supply voltage U_I



WARNING: Loss of safety function

The use of unsuitable power supplies can result in the loss of the safety function.

- Observe the general safety notes: see Section 1.2 “Electrical safety” on page 10.

Supply voltage U_I supplies the input circuits, the clock outputs, and the switching elements on the I/O side. Technical data for supply voltage U_I : see “Supply voltage U_I (sensors, clock outputs, I/O)” on page 81.

The maximum current carrying capacity via the U_1 connector is 8 A.

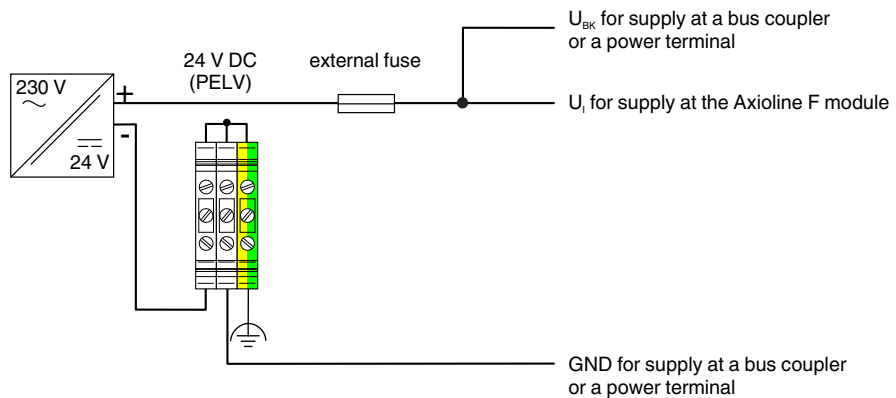


NOTE: Module damage

Parallel protection against polarity reversal is only implemented in the module for a limited period. The following measures must be taken to prevent damage to the module:

- Due to the maximum current carrying capacity of 8 A, protect power supply U_1 externally with an 8 AT fuse.
- Only use PELV power supply units with at least four times the nominal tripping current, as this is the only way to ensure tripping times of less than 300 ms.

The supply of supply voltage U_1 should feature a connection to functional earth ground according to EN 60204-1.



105738B000_en

Figure 3-1 Supply U_1 with connection to functional earth ground according to EN 60204-1

Observe the information regarding the behavior of the module in the event of an error at supply voltage U_1 ; see Section 9 “Errors: messages and removal” on page 71.

3.3 DC distribution network according to IEC 61326-3-1



NOTE: Damage to module electronics

A surge voltage will damage the module electronics.

- Do not use a DC distribution network.

A DC distribution network is a DC power supply network which supplies a complete industrial hall with DC voltage and to which any device is connected. A typical system or machine distribution is not a DC distribution network. For devices that are intended for a typical system or machine distribution, the DC connections are viewed and tested as I/O signals according to IEC 61326-3-1.

3.4 Terminal point assignment

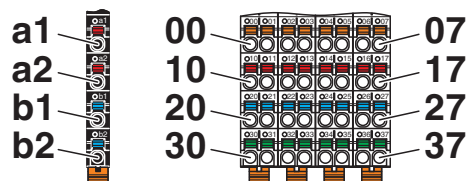


Figure 3-2 Terminal point assignment

The Axioline F connectors are supplied with the module. They are color coded and marked for connection.



Only use the connectors supplied with the module.

The following applies for the tables below:

- All inputs are safe digital inputs
- 0 V (GND): common ground of inputs and clock outputs
- FE: common functional earth ground
- T1: clock output 1
- T2: clock output 2

Table 3-1 Terminal point assignment of the voltage connection

| Terminal point | Color | Assignment | |
|----------------|-------|--------------|--|
| a1, a2 | Red | 24 V DC (UI) | UI: supply of the digital inputs (internally connected) |
| b1, b2 | Blue | GND | Reference potential of the supply voltage (internally connected) |

AXL F SSDI8/4 1F

Table 3-2 Terminal point assignment of the I/O connection

| | Color | Connector 1 (blue) | | Connector 2 (red) | | Connector 3 (white) | | Connector 4 (green) | |
|----------------|--------|--------------------|----------|-------------------|----------|---------------------|----------|---------------------|----------|
| Terminal point | Orange | 00 | 01 | 02 | 03 | 04 | 05 | 06 | 07 |
| Function | | IN0_CH1 | IN0_CH2 | IN1_CH1 | IN1_CH2 | IN2_CH1 | IN2_CH2 | IN3_CH1 | IN3_CH2 |
| Terminal point | Red | 10 | 11 | 12 | 13 | 14 | 15 | 16 | 17 |
| Function | | Clock T1 | Clock T2 | Clock T1 | Clock T2 | Clock T1 | Clock T2 | Clock T1 | Clock T2 |
| Terminal point | Blue | 20 | 21 | 22 | 23 | 24 | 25 | 26 | 27 |
| Function | | GND | GND | GND | GND | GND | GND | GND | GND |
| Terminal point | Green | 30 | 31 | 32 | 33 | 34 | 35 | 36 | 37 |
| Function | | FE | | | | | | | |

**WARNING: Loss of safety function**

Parasitic voltages can result in the loss of the safety function.

- Wire sensors that require a GND to the corresponding slot for 0 V (GND).

4 Assembly, removal, and electrical installation

4.1 Assembly and removal

4.1.1 Unpacking the module

**NOTE: Electrostatic discharge**

The module contains components that can be damaged or destroyed by electrostatic discharge.

- When handling the module, observe the safety precautions against electrostatic discharge (ESD) according to EN 61340-5-1 and IEC 61340-5-1.

- Read the package slip and follow the instructions.

The module may only be installed and removed by qualified personnel.

4.1.2 Preparation and assembly

**WARNING: Unintentional machine startup**

Make sure that the power to the system is disconnected before carrying out assembly and removal work as this could cause unintentional machine startup.

- Before assembling or removing the module, disconnect the power to the module and the entire Axioline F station and make sure that the system cannot be switched on again.
- Make sure the entire system is reassembled before switching the power back on and that neither the station nor the system poses a hazard.

Observe the diagnostics indicators and any diagnostic messages.

- Mount the module on a 35 mm DIN rail in a control cabinet or junction box protected from dust and humidity (IP54 or higher).
- Secure the control cabinet/junction box to prevent unauthorized opening.
- Only connect the cables using the supplied Axioline F connectors.

4.1.3 Setting the DIP switch

A DIP switch is located on the top of the module.

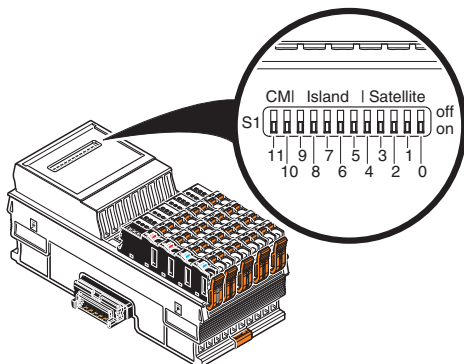


Figure 4-1 DIP switch

12-pos. DIP switch: address and operating mode

Set the SafetyBridge address and the operating mode via the 12-pos. DIP switch.

Overview of the switch positions

Table 4-1 Switch position

| Operating mode | Reserved | SafetyBridge address | | | | | | | | | |
|----------------|----------|---------------------------------------|---|---|---|---|---------------------------------------|---|---|---|---|
| | | Island number | | | | | Satellite number | | | | |
| 11 | 10 | 9 | 8 | 7 | 6 | 5 | 4 | 3 | 2 | 1 | 0 |
| off/on | on | 1 _{dec} to 31 _{dec} | | | | | 1 _{dec} to 16 _{dec} | | | | |

- Switch 0 to 9:** SafetyBridge address
- Switch 10:** Reserved Always **on**
- Switch 11:** Operating mode **off** = SafetyBridge mode **on** = startup mode



Position 10 of the 12-pos. DIP switch is reserved and must always be in the “on” position. Otherwise, the module responds with a failure state.

Setting the address

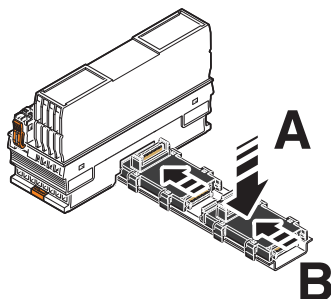
- Remove the marking field and set the address in the switch below it.
- Reattach the marking field to the module.



The set address is only applied on power up. If the address is adjusted during operation, the module responds with a failure state.

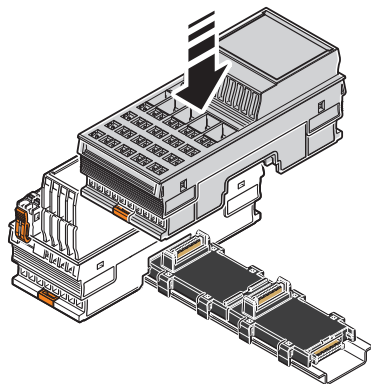
4.1.4 Mounting and removing modules

Mounting the bus base module



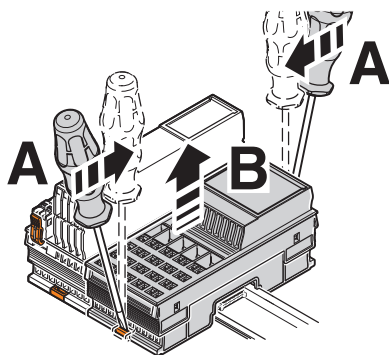
- Place all bus base modules required for the station on the DIN rail (A).
- Push the bus base modules into the connection for the bus coupler or the previous bus base module (B).

Snapping on and removing the electronics module



Snap on

- Place the electronics module vertically on the corresponding bus base module on the DIN rail until it snaps into place with a click. Make sure that the device connector for the bus base connection is situated above the corresponding socket on the bus base module.

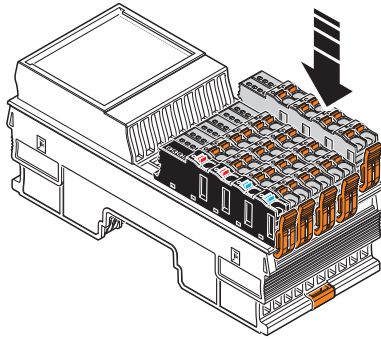


Remove

- Before removing the module, remove all connectors.
- Insert a suitable tool (e.g., bladed screwdriver) into the upper and lower snap-on mechanisms (base latches) of the module one after the other to release it (A).
- Remove the module perpendicular to the DIN rail (B).

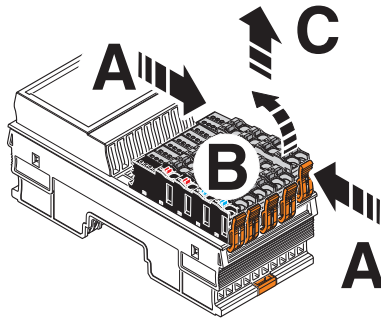
AXL F SSDI8/4 1F

Inserting and removing the connector



Insert

- Place the connector vertically into its position.
Note the color markings of the connectors/slots.
Assignment from left to right: blue, red, white, green.
- Press firmly on the connector. Make sure that the locking latch snaps in.



Remove

- Release the locking latch (A).
- Tilt the connector upwards slightly (B).
- Remove the connector from the module (C).

4.2 Electrical installation



WARNING: Electric shock/unintentional machine startup

Make sure that the power to the system is disconnected before carrying out installation work as this could cause a hazardous electric shock as well as unintentional machine startup.

- Prior to installation work, disconnect the power to the system and make sure that it cannot be switched on again unintentionally.
- Make sure all work is completed before switching the power back on and that neither the station nor the system poses a hazard.
Observe the diagnostics indicators and any diagnostic messages.

4.2.1 Electrical installation of the Axioline F station

Electrical installation of the Axioline F station includes the following:

- Connection to the higher-level bus system
- Connecting the supply voltages for the Axioline F station
- Carry out electrical installation for the Axioline F station according to the following user manuals:
 - Axioline F: system and installation user manual, UM EN AXL F SYS INST
 - Axioline F system manual for your bus system
- Observe the additional information in the documentation for the bus coupler.

4.2.2 Electrical installation of the module



Observe the general safety notes: see Section 1.2 “Electrical safety” on page 10.



WARNING: Loss of safety function/damage to equipment

Improper installation, e.g., due to the mismatching or polarity reversal of connections, can result in the loss of the safety function as well as damage to equipment.

- Take measures to prevent the mismatching or polarity reversal of connections.
- Prevent the tampering of connections.

The supply voltage for the module electronics is fed to the bus coupler. From this, the supply voltage of the module logic is provided via the bus base module. The supply voltage of the input circuits, clock outputs, and I/O devices is fed directly to the module.

The sensors are connected via Axioline F connectors.

- Wire the connectors according to your application: see Section 3.4 “Terminal point assignment” on page 27.

AXL F SSDI8/4 1F

5 Parameterization of the module

5.1 Parameterization in a SafetyBridge system

Parameterization includes the following:

- Assigning the SafetyBridge address
- Parameterizing inputs



The communication address configured in the controller project must match the address set on the device.

The settings on the device take effect after a power up.

SafetyBridge address

The SafetyBridge address is a unique ID for the safety module in the SafetyBridge structure. It is assigned in the configuration software for the assigned logic module.

The address of the connected satellites (here: AXL F SSDI8/4 1F) is based on the island number of the logic module and the position in the bus navigator of the configuration software.

- Set the address of the safety module via the DIP switch (see see “Setting the DIP switch” on page 30).



For more detailed information on the SafetyBridge address, please refer to the documentation for the logic module used.

Parameterization of the inputs and clock outputs

The parameterization of the safe inputs determines the behavior of the module and influences the safety integrity that can be achieved.

The controller automatically writes the parameterization created in the configuration software to the module on every power up, reset or deactivation/activation of the “Operate” function block.

The following conditions must be met:

- Supply voltage is present
- Local bus is in the RUN state
- Communication connection has been established between the controller and the module

The module cannot be operated if it is not parameterized. The FS LED flashes.

The module is ready to operate if the parameters for all inputs are valid and transmitted without errors. Valid input data is only read in this state. In every other state, the safe state is transmitted for each input (“0” in the process image of the inputs).

If errors are detected during parameterization, the parameterization data is not applied. The FS LED flashes to indicate that the parameterization is invalid.

In addition, the error is reported to the controller.

- In this case, check and correct the settings.

Information on error messages and troubleshooting: see Section 9 “Errors: messages and removal” on page 71.

5.2 Parameterization of the safe inputs

The individual input pairs of a module can be parameterized differently, which means that different safety integrity levels (SIL, SILCL, Cat., PL) can be achieved.

Two-channel

The following fixed assignment applies for two-channel operation:

- IN0_Ch1 to IN0_Ch2
- IN1_Ch1 to IN1_Ch2
- IN2_Ch1 to IN2_Ch2
- IN3_Ch1 to IN3_Ch2

The input information of both inputs is mapped to one bit. The unused bits are always set to “0”.

Single-channel

For single-channel assignment, the inputs can be parameterized so that they operate independently of one another.

Parameterization

The safe inputs are parameterized in pairs for each connector. Table 5-1 describes the parameterization options.

Table 5-1 Parameterization of each input pair

| Parameterization | Value range | Comment |
|---|--|--|
| Assignment | <ul style="list-style-type: none"> – Not assigned – Assigned <ul style="list-style-type: none"> – Both single-channel – Two-channel equivalent – Two-channel non-equivalent | Parameterize the input pairs in pairs. For unused inputs, the data is filled with “0”. In two-channel operation, the inputs have a fixed assignment to one another. |
| Filter time (t_{Filter}) | <ul style="list-style-type: none"> – 1.5 ms – 3 ms – 5 ms – 15 ms | The filter time is used to suppress interference for the input signals. Select the filter time so that the duration of the input signal is greater than the filter time. ⚠ WARNING: The filter time affects the response time of the safety function. |
| Symmetry | <ul style="list-style-type: none"> – Disabled – 100 ms – 1 s – 5 s | Parameterization is only active if the input is parameterized for two-channel operation. See also see “Symmetry/ start inhibit” on page 37. |
| Start inhibit due to symmetry violation | <ul style="list-style-type: none"> – Disabled – Enabled | Disabled: only a diagnostic message is generated in the event of symmetry violation. Enabled: a diagnostic message is generated in the event of symmetry violation. In addition, the affected input is set to the safe state. |
| Cross-circuit detection | <ul style="list-style-type: none"> – No cross-circuit monitoring – Cross-circuit monitoring <ul style="list-style-type: none"> – INx_CH1 -> T1 – INx_CH2 -> T2 | As soon as cross-circuit monitoring is enabled for an assigned input pair, clock outputs T1 and T2 are clocked. Otherwise the clock outputs are enabled without clocking. |
| The default values are shown in bold . | | |

**Symmetry/
start inhibit**

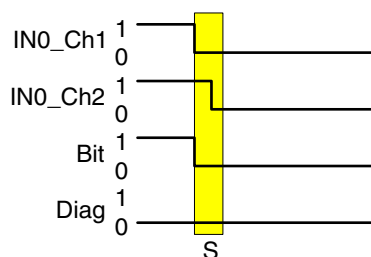
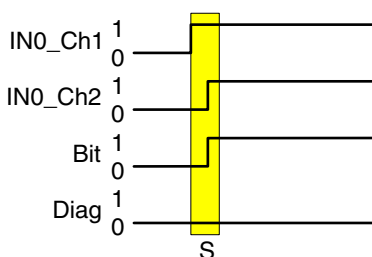
Symmetry monitoring can be used to monitor the contact wear of the switch. Symmetry monitoring checks the extent to which the related (filtered) inputs enter another state simultaneously. Symmetry is violated if the inputs indicate different states for a time greater than the value parameterized for "symmetry". This applies for positive and negative edges.

Key for the following diagrams:

- S Set time for symmetry monitoring
- Diag Diagnostics
- Bit Transmitted state of the inputs
- Q Acknowledgment of the diagnostic message. After acknowledging the diagnostic message, the current state is read in.

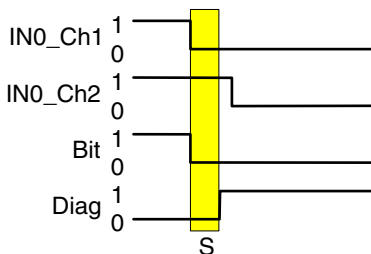
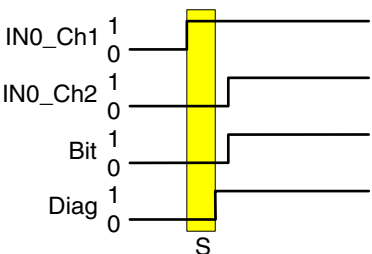


For non-equivalent parameterization, a negated signal is present at input IN0_Ch2 as illustrated.



76020007

Figure 5-1 Example for a signal change in the parameterized time for symmetry monitoring



76020008

Figure 5-2 Example for a signal change outside the parameterized time for symmetry monitoring, start inhibit due to symmetry violation is disabled

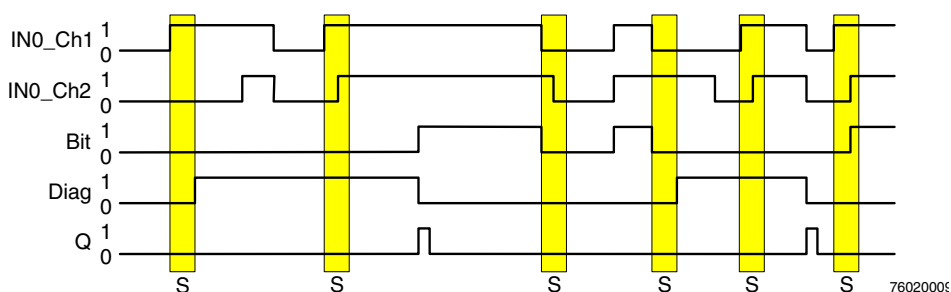


Figure 5-3 Example for a signal change outside the parameterized time for symmetry monitoring, start inhibit due to symmetry violation is enabled



After acknowledging the diagnostic message, the current state at the input is immediately transmitted to the logic module.

- If required, implement a startup inhibit in the application program following error acknowledgment.

See also see “Errors: messages and removal” on page 71.



A symmetry violation can also be triggered by a cross circuit: see Section 7 “Connection examples for safe inputs” on page 41.

Processing time of input t_{IN} in the event of a safety demand

The processing time of input t_{IN} in the event of a safety demand consists of the parameterized filter time t_{Filter} and the firmware runtime t_{FW} :

$$t_{IN} = t_{Filter} + t_{FW}$$

Where:

- t_{IN} Processing time of the input
- t_{Filter} Parameterized filter time
- t_{FW} Firmware runtime: 1 ms

6 Duration of a safety demand

The duration of a safety demand must be greater than the processing time of the corresponding input t_{IN} : see “Processing time of input t_{IN} in the event of a safety demand” on page 38.

If the safety module detects a safety demand after the processing time of the input t_{IN} has elapsed, when using SafetyBridge this time is extended by the module until the logic module has received the safety demand.

AXL F SSDI8/4 1F

7 Connection examples for safe inputs

7.1 Explanation of the examples



WARNING: Loss of safety function

Improperly executed applications can result in the loss of the safety function.

- Observe the information to achieve the specified category: see Section 7.2 “Measures to achieve a specific safety integrity” on page 42.
- Make sure that the sensor has appropriate diagnostic coverage and an appropriate MTTFd to achieve the specified PL.
For applications according to PL d, high diagnostic coverage (> 99%) is recommended, however medium diagnostic coverage (90% to 99%) and a medium MTTFd are required at the very least.
For applications according to PL e, high diagnostic coverage (> 99%) and a high MTTFd are required.
- Use sensors that can achieve the required safety integrity.



- For the examples, please also observe the measures specified in the tables as well as standards IEC 61508, EN 62061, and EN ISO 13849-1 to achieve the specified SIL/SILCL/Cat./PL.



The above notes apply in general for all of the connection examples in this section.

- Also observe the notes listed in the individual connection examples.

If the settings do not contradict one another, the inputs of a module can achieve different safety integrity levels (SIL, SILCL, Cat., PL) simultaneously.

The examples only describe the options for the electrical connection of sensors to the safe inputs.

Should you have any questions regarding your applications, please contact the Phoenix Contact safety hotline: see Section 1.8 “Safety hotline” on page 12.

The following are specified for each example:

- **Basic specifications**
The table specifies the main data for the example.
- **Device diagnostics and behavior of the module in the event of an error**
Diagnostic capability depends on the parameterization.
If a message is generated for an error, the message is specified in the tables.
Information on the error code as well as possible solutions and information as to whether the error message must be acknowledged: see Section 9 “Errors: messages and removal” on page 71.
The symmetry violation diagnostic message is only displayed if it was not disabled during parameterization of the affected input.
- **Typical parameterization**
The table illustrates an example of all the parameters for the specified assignment.

AXL F SSDI8/4 1F

Key for tables in this section:

| Representation | Meaning |
|----------------|---|
| Bold | Mandatory setting |
| Normal | Typical setting, another setting is possible depending on the application |
| – | Not evaluated |

Errors (cross-circuits, short circuits) which can be prevented by correct installation (e.g., protected cable installation, isolated cable installation, double insulation, use of ferrules) are not described in the tables.

Only errors between inputs, which are on the same connector, are described. For example, in the event of correct installation, cross-circuits with inputs/outputs of other connectors cannot occur.

7.2 Measures to achieve a specific safety integrity

The safety integrity (SIL, SILCL, category, and performance level) that can be achieved is specified for each connection example.

SIL/SILCL



Use the standard to determine the probability of failure in your application according to IEC 61508 (SIL) and EN 62061 (SILCL).

Table 7-1 PFD and PFH depending on the SIL/SILCL

| Safety integrity | PFD | PFH |
|------------------|-----------------|-----------------|
| SIL 2/SILCL 2 | 1% of 10^{-2} | 1% of 10^{-6} |
| SIL 3/SILCL 3 | 1% of 10^{-3} | 1% of 10^{-7} |

Performance level



Use standard EN ISO 13849-1 to determine the performance level.

Connection examples for safe inputs

Category

The categories are achieved with the following measures:

| Measure | Cat. 2 | Cat. 3 | Cat. 4 |
|--|--------|--------|--------|
| Use proven and basic safety principles according to EN ISO 13849-2. | x | x | x |
| Use qualified sensors: see "Requirements for sensors/controlling devices" on page 15. | x | x | x |
| Please note that mechanical failure of the switching device can result in the loss of the safety function. | x | x | x |
| Prevent (e.g., by means of protection, redundancy, positive opening operation) contacts from failing to open (e.g., due to welding or mechanical failure) when a switch is actuated. | x | x | |
| Please note that a single error can result in the loss of the safety function between tests. | x | | |
| Make sure that the external wiring is tested by the machine controller on machine startup and at suitable intervals. This test must detect the loss of the safety function. | x | | |
| Please take into consideration errors with a common cause. | | x | x |
| Please note that all errors that cannot be detected can result in the loss of the safety function. Take measures to prevent these errors (e.g., protected cable installation or double insulation). Observe the notes in the following tables. | | x | x |
| Make sure that a single error does not result in the loss of the safety function. | | x | |
| If single-channel sensors are not available for this category, use two-channel sensors. | | x | |
| An accumulation of errors must not result in the loss of the safety function. Following the third error, evaluation can be aborted if the probability of further errors occurring is low. | | | x |

7.3 Single-channel assignment of safe inputs

For the single-channel assignment of safe inputs, the inputs operate independently of one another. The assignment of each input signal to the clock output cannot be freely selected.

7.3.1 Notes

Please observe the following notes:

Cross-circuit

- Please note that cross-circuits with other inputs can only be detected if cross-circuit monitoring is enabled.

The cross-circuit error results in the transmission of the safe state in the process data image of the affected inputs.

- Remove the error and then acknowledge the message.
- Observe the maximum failure detection time of 64 ms.

If a “1” signal is present at the input and an error occurs, a maximum of 64 ms elapses until the error is detected. During this time, another “1” can be transmitted, even in the event of an error.

During the failure detection time (64 ms, maximum), the error can cause the state to change unexpectedly from “0” to “1”.

- Make sure that the system cannot be restarted unintentionally as a result of this change in state.
- Please note that the processing time for the input t_{IN} increases by up to 64 ms in the event of an error.

For the power supply for single-channel assignment, use the relevant clock output or an external power supply (external +24 V or OSSD).

State evaluation

The module evaluates the states of the inputs and transmits the result to the logic module.

The following values are transmitted in the process data image of a safe input:

- “0” if a “0” signal is present at the input **or** an error has been detected
- “1” if a “1” signal is present at the input **and** no error has been detected

7.3.2 Cross-circuit monitoring enabled

If an input pair is parameterized as single-channel with cross-circuit monitoring, the fixed assignment is as follows:

- INx_Ch1 is permanently assigned to clock output T1
- INx_Ch2 is permanently assigned to clock output T2



Figure 7-1 Single-channel assignment of inputs

Connection examples for safe inputs

Basic specifications

| | |
|------------------------------------|--|
| Sensor | Single-channel |
| Sensor supply | Internally through clock output T1 (clocked) or T2 (clocked) |
| Achievable safety integrity | SIL 2/SILCL 2/Cat. 3/PL d |

Device diagnostics and behavior of the module in the event of an error

Table 7-2 Single-channel: supply through T1 (clocked) or T2 (clocked)

| Error type | Detection | Diagnostics | Loss of SF ¹ | Comment |
|---|------------------|---------------|-------------------------|---|
| Error in the sensor | | | | |
| A contact fails to open | No | None | Yes | The error cannot be detected and results in the loss of the safety function. |
| A contact fails to close | No | None | No | The error cannot be detected. |
| Other errors (depending on the sensor) | | | | Please take into consideration errors that can occur in the sensor. |
| Error in the wiring | | | | |
| Interrupt | | | | |
| Input (cable interrupt between clock output and sensor or between sensor and input) | Yes | None | No | – Behavior when the input is in state “1”: The error is detected as a change in state from “1” to “0”. An unexpected change from “0” to “1” is possible. Make sure that this change in state cannot restart the system unintentionally. – Behavior when the input is in state “0”: Please note that if this error causes the safety switch to be switched on again, this can result in delayed transmission of state “1” in the process data image of the inputs. |
| Cross-circuit | | | | |
| Input to input | No | None | Yes | The error cannot be detected and results in the loss of the safety function, as the safety switch is bypassed. If the inputs are assigned to different clock outputs, this error is detected as a cross-circuit after 64 ms. |
| Input to assigned clock output | No | None | Yes | The error cannot be detected and results in the loss of the safety function, as the safety switch is bypassed. |
| Input to non-assigned clock output | Yes | Cross-circuit | No | see “Cross-circuit” on page 44 |
| Clock output to clock output | Yes if state “1” | Cross-circuit | No | The error is only detected in state “1” of the input. |
| Short circuit | | | | |
| Input to ground | Yes | None | No | The error is only detected as a change in state from “1” to “0” in state “1” of the input. An unexpected change from “0” to “1” is possible. Make sure that this change in state cannot restart the system unintentionally. |
| Clock output to ground | Yes | Short circuit | No | The affected clock output is disabled. |

¹ SF = safety function

AXL F SSDI8/4 1F

Typical parameterization

| Parameterization | Parameterized as/value range | Comment |
|---|---------------------------------|----------------------|
| Input xx channel 1/channel 2 | | |
| Assignment | Both single-channel | |
| Filter time (t_{Filter}) | 3 ms | Application-specific |
| Symmetry | Disabled | |
| Start inhibit due to symmetry violation | Disabled | |
| Cross-circuit monitoring | Cross-circuit monitoring | |

7.3.3 Cross-circuit monitoring disabled, supply through T1



Figure 7-2 Single-channel assignment of inputs: supply through T1

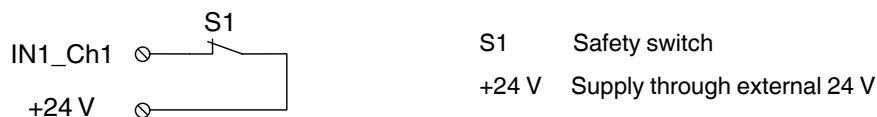


Figure 7-3 Single-channel assignment of inputs: external supply

Basic specifications

| | |
|------------------------------------|--|
| Sensor | Single-channel switch |
| Sensor supply | <ul style="list-style-type: none"> - Internally through clock output T1 or T2; cross-circuit monitoring disabled - External (24 V) |
| Achievable safety integrity | SIL 2/SILCL 2/Cat. 2/PL d |



WARNING: Loss of safety function

Cross-circuits can result in the loss of the safety function.

- Prevent cross-circuits to achieve the specified PL.

Connection examples for safe inputs

Device diagnostics and behavior of the module in the event of an error

Table 7-3 Single-channel without cross-circuit monitoring: supply through T1/T2, external supply or OSSD

| Error type | Detection | Diagnostics | Loss of SF ¹ | Comment |
|---|------------------|---------------|-------------------------|---|
| Error in the sensor | | | | |
| A contact fails to open | No | None | Yes | The error cannot be detected and results in the loss of the safety function. |
| A contact fails to close | No | None | No | The error cannot be detected. |
| Other errors (depending on the sensor) | | | | Please take into consideration errors that can occur in the sensor. |
| Error in the wiring | | | | |
| Interrupt | | | | |
| Input (cable interrupt between clock output and sensor or between sensor and input) | Yes | None | No | <p>– Behavior when the input is in state “1”: The error is detected as a change in state from “1” to “0”. An unexpected change from “0” to “1” is possible. Make sure that this change in state cannot restart the system unintentionally.</p> <p>– Behavior when the input is in state “0”: Please note that if this error causes the safety switch to be switched on again, this can result in delayed transmission of state “1” in the process data image of the inputs.</p> |
| Cross-circuit | | | | |
| Input to input | No | None | Yes | The error cannot be detected and results in the loss of the safety function, as the safety switch is bypassed. |
| Input to clock output | No | None | Yes | The error cannot be detected and results in the loss of the safety function, as the safety switch is bypassed. |
| Short circuit | | | | |
| Input to external 24 V | No | None | Yes | The error cannot be detected and results in the loss of the safety function, as the safety switch is bypassed. |
| Input to ground | Yes if state “1” | None | No | The error is only detected as a change in state from “1” to “0” in state “1” of the input. An unexpected change from “0” to “1” is possible. Make sure that this change in state cannot restart the system unintentionally. |
| Clock output to external 24 V | No | None | No | The error cannot be detected as clocking is disabled. |
| Clock output to ground | Yes | Short circuit | No | The affected clock output is disabled. |
| External 24 V to ground | Yes | None | No | The error is only detected as a change in state from “1” to “0” in state “1” of the input. An unexpected change from “0” to “1” is possible. Make sure that this change in state cannot restart the system unintentionally. |

¹ SF = safety function

AXL F SSDI8/4 1F

Typical parameterization

| Parameterization | Parameterized as/value range | Comment |
|---|------------------------------------|----------------------|
| Input xx channel 1/channel 2 | | |
| Assignment | Both single-channel | |
| Filter time (t_{Filter}) | 3 ms | Application-specific |
| Symmetry | Disabled | |
| Start inhibit due to symmetry violation | Disabled | |
| Cross-circuit monitoring | No cross-circuit monitoring | |

7.3.4 Supply through OSSD

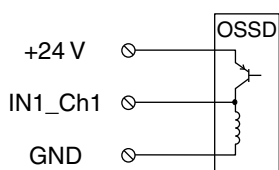


Figure 7-4 Single-channel assignment of inputs: external supply (OSSD)



WARNING: Loss of safety function

Parasitic voltages can result in the loss of the safety function.

- Connect the sensor ground directly to terminal point GND of the module. An external ground may not be used.

Basic specifications

| | |
|------------------------------------|--|
| Sensor | Single-channel OSSD output (with internal testing) |
| Sensor supply | External (OSSD sensor) |
| Achievable safety integrity | SIL 2/SILCL 2/Cat. 2/PL d |



WARNING: Loss of safety function

Cross-circuits can result in the loss of the safety function.

- Prevent cross-circuits to achieve the specified PL.

Connection examples for safe inputs

Device diagnostics and behavior of the module in the event of an error

Table 7-4 Single-channel: supply through OSSD

| Error type | Detection | Diagnostics | Loss of SF ¹ | Comment |
|---|------------------|---------------|-------------------------|---|
| Error in the sensor | | | | |
| (depending on the sensor) | | | | Please take into consideration errors that can occur in the sensor. |
| Error in the wiring | | | | |
| Interrupt | | | | |
| Input (cable interrupt between sensor and input) | Yes | None | No | <p>– Behavior when the input is in state “1”: The error is detected as a change in state from “1” to “0”. An unexpected change from “0” to “1” is possible. Make sure that this change in state cannot restart the system unintentionally.</p> <p>– Behavior when the input is in state “0”: Please note that if this error causes the safety switch to be switched on again, this can result in delayed transmission of state “1” in the process data image of the inputs.</p> |
| Input (cable interrupt between sensor and GND) | No | None | No | The sensor must detect the error. The sensor must ensure that the safe state is entered in the event of an error. |
| Cross-circuit | | | | |
| Input to input | No | None | Yes | The error cannot be detected and results in the loss of the safety function, as the safety switch is bypassed. |
| Input to clock output | No | None | Yes | The error cannot be detected and results in the loss of the safety function, as the safety switch is bypassed. |
| Short circuit | | | | |
| Input to external 24 V | No | None | Yes | The error cannot be detected and results in the loss of the safety function, as the safety switch is bypassed. |
| Input to ground | Yes if state “1” | None | No | The error is only detected as a change in state from “1” to “0” in state “1” of the input. An unexpected change from “0” to “1” is possible. Make sure that this change in state cannot restart the system unintentionally. |
| Clock output to external 24 V | No | None | No | The error cannot be detected as clocking is disabled. |
| Clock output to ground | Yes | Short circuit | No | The affected clock output is disabled. |
| External 24 V to ground | Yes | None | No | The error is only detected as a change in state from “1” to “0” in state “1” of the input. An unexpected change from “0” to “1” is possible. Make sure that this change in state cannot restart the system unintentionally. |

¹ SF = safety function

AXL F SSDI8/4 1F

Typical parameterization

| Parameterization | Parameterized as/value range | Comment |
|---|------------------------------------|----------------------|
| Input xx channel 1/channel 2 | | |
| Assignment | Both single-channel | |
| Filter time (t_{Filter}) | 3 ms | Application-specific |
| Symmetry | Disabled | |
| Start inhibit due to symmetry violation | Disabled | |
| Cross-circuit monitoring | No cross-circuit monitoring | |



Set the filter time for the input to a value greater than the width of the test pulse for the OSSD sensor.
The input must be parameterized without cross-circuit monitoring.

7.4 Two-channel equivalent assignment of safe inputs

For two-channel assignment of the inputs, two adjacent inputs of the same connector are always used. This assignment cannot be parameterized: see “Two-channel” on page 36.

For two-channel equivalent assignment, the state changes from “0” to “1” only when both inputs change state from “0” to “1”. If symmetry monitoring is enabled and the state at both inputs does not change within the parameterized time, a diagnostic message is generated.

The input is active when the state of the signal is “1”.



Please note that if a delayed change in state at one of the two inputs causes the safety switch to be switched on again, this can result in delayed transmission of state “1” in the process data image of the inputs.

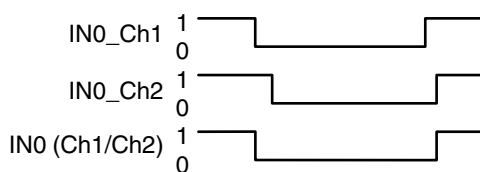
Example of correct and incorrect signal change

Figure 7-5 Correct signal change

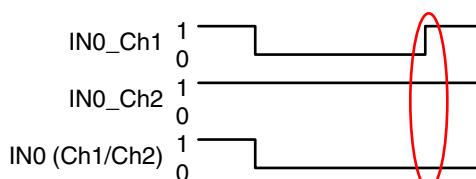


Figure 7-6 Error during signal change

Key for Figure 7-5 and Figure 7-6

| | |
|---------------|--|
| IN0_Ch1 | Signal sequence at input 0 channel 1 |
| IN0_Ch2 | Signal sequence at input 0 channel 2 |
| IN0 (Ch1/Ch2) | Safety-related signal for two-channel input 0, channel 1 and channel 2 at the logic module |

In Figure 7-6, the condition that both signals must be in state "0" before the change in state from "0" to "1" is not met. In this case, the diagnostic message is generated.

State evaluation

The module evaluates the states of the inputs and transmits the result to the logic module.

The following values are transmitted in the process data image of the safe inputs:

- "0" if a "0" signal is present at at least one of the two inputs **or** an error has been detected
- "1" if a "1" signal is present at both inputs **and** no error has been detected and the conditions are met for a change in state according to Figure 7-6

7.4.1 Notes on errors

Please observe the following notes on cross-circuit and symmetry violation:

Cross-circuit

The **cross-circuit** error results in the transmission of the safe state in the process data image of the affected inputs.

- Remove the error and then acknowledge the message.

Acknowledging the diagnostic message deletes the message and activates the input. The states at the input are detected immediately.

- In the safe application program, make sure that the system cannot be restarted unintentionally after acknowledging the diagnostic message.
- Observe the maximum failure detection time of 64 ms.

Exceptions in the failure detection time are indicated in the tables below.

If a “1” signal is present at the input and an error occurs, a maximum of 64 ms elapses until the error is detected. During this time, another “1” can be transmitted, even in the event of an error.

During the failure detection time, the error can cause the state to change unexpectedly from “0” to “1”.

- Make sure that the system cannot be restarted unintentionally as a result of this change in state.

Symmetry violation

- The symmetry violation diagnostic message is only displayed if it was not disabled during parameterization of the affected input.
- **Start inhibit due to symmetry violation disabled:**
The symmetry violation message does **not** result in the transmission of the safe state: see “Symmetry/ start inhibit” on page 37.
The message must be acknowledged. However, the current status of the inputs is always displayed in the process data image of the inputs.
- **Start inhibit due to symmetry violation enabled:**
The symmetry violation message results in the transmission of the safe state: see “Symmetry/ start inhibit” on page 37.
The message must be acknowledged. Following acknowledgment, the current status of the inputs is displayed in the process data image of the inputs.
- The message can be used to monitor the wear of the safety switch.

7.4.2 Cross-circuit monitoring enabled, supply through T1 and T2

Possible wiring versions:

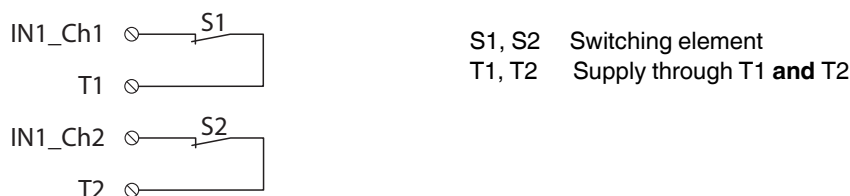


Figure 7-7 Two-channel equivalent assignment of inputs, supply through T1 and T2 (both clocked)

Basic specifications

| | |
|------------------------------------|---|
| Sensor | Two-channel equivalent with cross-circuit monitoring |
| Sensor supply | Internally through clock output T1 and T2 (both clocked) |
| Achievable safety integrity | SIL 3/SILCL 3/Cat. 4/PL e |

Device diagnostics and behavior of the module in the event of an error



Observe the information to understand the change in state: see “Example of correct and incorrect signal change” on page 51.

Table 7-5 Two-channel equivalent with cross-circuit monitoring: supply through T1 and T2

| Error type | Detection | Diagnostics | Loss of SF ¹ | Comment |
|---|-----------|---------------------------------|-------------------------|---|
| Error in the sensor | | | | |
| A contact fails to open | Yes | Symmetry violation ² | No | The error is detected on a change in state, as the state only changes in one channel. – Change in state from “1” to “0”: The faulty input remains at “1”. A “0” is transmitted in the process data image of the affected inputs. – Change in state from “0” to “1”: A “0” is transmitted in the process data image of the affected inputs, as the faulty input was not previously set to state “0”. |
| A contact fails to close | Yes | Symmetry violation ² | No | On a change in state from “0” to “1”, a “0” is transmitted in the process data image of the affected inputs, as only one channel reports this change in state. |
| Other errors (depending on the sensor) | | | | Please take into consideration errors that can occur in the sensor. |
| Error in the wiring | | | | |
| Interrupt | | | | |
| Input (cable interrupt between clock output and sensor or between sensor and input) | Yes | Symmetry violation ² | No | The error is detected in state “1” or on a change in state from “0” to “1”, as the state only changes in one channel. |
| Cross-circuit | | | | |
| Input to input | Yes | Cross-circuit | No | The error is detected in state “1” |

AXL F SSDI8/4 1F

Table 7-5 Two-channel equivalent with cross-circuit monitoring: supply through T1 and T2 [...]

| Error type | Detection | Diagnostics | Loss of SF ¹ | Comment |
|------------------------------------|-----------|---------------------------------|-------------------------|--|
| Input to assigned clock output | Yes | Symmetry violation ² | No | The error is detected on a change in state, as the state only changes in one channel. – Change in state from “1” to “0”: The faulty input remains at “1”. A “0” is transmitted in the process data image of the affected inputs. – Change in state from “0” to “1”: A “0” is transmitted in the process data image of the inputs, if the faulty input was not previously set to state “0”. |
| Input to non-assigned clock output | Yes | Cross-circuit | No | see “Cross-circuit” on page 52. |
| Clock output to clock output | Yes | Cross-circuit | No | The error is detected for inputs which are assigned to different clock outputs. |
| Short circuit | | | | |
| Input to ground | Yes | Symmetry violation ² | No | The error is detected in state “1” or on a change in state from “0” to “1”, as the state only changes in one channel. |
| Clock output to ground | Yes | Short circuit | No | The error is detected in state “1” or on a change in state from “0” to “1”, as the state only changes in one channel. The error is also detected as a short circuit of the clock output. The affected clock output is disabled. |

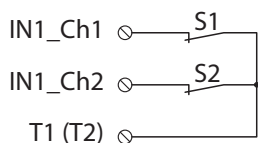
¹ SF = safety function

² Only applies when symmetry monitoring is active

Typical parameterization

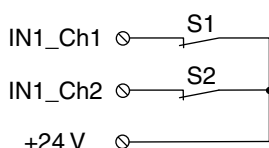
| Parameterization | Parameterized as/value range | Comment |
|---|---------------------------------|----------------------|
| Input xx channel 1/channel 2 | | |
| Assignment | Two-channel equivalent | |
| Filter time (t_{Filter}) | 3 ms | Application-specific |
| Symmetry | 100 ms | Application-specific |
| Start inhibit due to symmetry violation | Enabled | Application-specific |
| Cross-circuit monitoring | Cross-circuit monitoring | |

7.4.3 Cross-circuit monitoring disabled, supply through a clock output or external supply



S1, S2 Two switching elements
T1 (T2) Supply through T1 or T2

Figure 7-8 Two-channel equivalent assignment of inputs, supply through T1 (or T2), cross-circuit monitoring disabled



S1, S2 Two switching elements
+24 V External supply

Figure 7-9 Two-channel equivalent assignment of inputs, external supply, cross-circuit monitoring disabled

Basic specifications

| | |
|------------------------------------|--|
| Sensor | Two-channel equivalent |
| Sensor supply | Internally through clock output T1 (or T2) or externally |
| Achievable safety integrity | SIL 3/SILCL 3/Cat. 3/PL d |



Observe the information to understand the change in state: see “Example of correct and incorrect signal change” on page 51.

AXL F SSDI8/4 1F

Device diagnostics and behavior of the module in the event of an error

Table 7-6 Two-channel equivalent, cross-circuit monitoring disabled: supply through a clock output or external supply

| Error type | Detection | Diagnostics | Loss of SF ¹ | Comment |
|--|-----------|---------------------------------|-------------------------|---|
| Error in the sensor | | | | |
| A contact fails to open | Yes | Symmetry violation ² | No | The error is detected on a change in state, as the state only changes in one channel. – Change in state from “1” to “0”: The faulty input remains at “1”. A “0” is transmitted in the process data image of the affected inputs. – Change in state from “0” to “1”: A “0” is transmitted in the process data image of the affected inputs, as the faulty input was not previously set to state “0”. |
| A contact fails to close | Yes | Symmetry violation ² | No | On a change in state from “0” to “1”, a “0” is transmitted in the process data image of the affected inputs, as only one channel reports this change in state. |
| Other errors (depending on the sensor) | | | | Please take into consideration all errors that can occur in the sensor. |
| Error in the wiring | | | | |
| Interrupt | | | | |
| Cable interrupt between clock output or external supply and sensor | Yes | None | No | – Behavior when the input is in state “1”: The error is detected as a change in state from “1” to “0”. An unexpected change from “0” to “1” is possible. Make sure that this change in state cannot restart the system unintentionally. |
| Cable interrupt between sensor and input | Yes | Symmetry violation ² | No | The error is detected in state “1” or on a change in state from “0” to “1”, as the state only changes in one channel. |
| Cross-circuit | | | | |
| Input to input | No | None | No | An accumulation of errors can result in the loss of the safety function. |
| Input to clock output | Yes | Symmetry violation ² | No | The error is detected on a change in state, as the state only changes in one channel. – Change in state from “1” to “0”: The faulty input remains at “1”. A “0” is transmitted in the process data image of the affected inputs. – Change in state from “0” to “1”: A “0” is transmitted in the process data image of the inputs, if the faulty input was not previously set to “0”. |
| Clock output to clock output | No | None | No | The error is not detected. |
| Short circuit | | | | |
| Input to external 24 V | Yes | Symmetry violation ² | No | The error is detected on a change in state, as the state only changes in one channel. – Change in state from “1” to “0”: The faulty input remains at “1”. A “0” is transmitted in the process data image of the affected inputs. – Change in state from “0” to “1”: A “0” is transmitted in the process data image of the inputs, as the faulty input was not previously set to “0”. |
| Input to ground | Yes | None | No | The error is detected in state “1” or on a change in state from “0” to “1”, as the state only changes in one channel. |
| Clock output that is not clocked to external 24 V | No | None | No | The error is not detected. |
| Clock output to ground | Yes | Short circuit | No | The error is detected as a change in state from “1” to “0”. An unexpected change from “0” to “1” is possible. Make sure that this change in state cannot restart the system unintentionally. The error is also detected as a short circuit of the clock output. The affected clock output is disabled. |

Connection examples for safe inputs

Table 7-6 Two-channel equivalent, cross-circuit monitoring disabled: supply through a clock output or external supply

| Error type | Detection | Diagnostics | Loss of SF ¹ | Comment |
|-------------------------|-----------|-------------|-------------------------|--|
| External 24 V to ground | Yes | None | No | The error is detected as a change in state from "1" to "0". An unexpected change from "0" to "1" is possible. Make sure that this change in state cannot restart the system unintentionally. |

¹ SF = safety function

² Only applies when symmetry monitoring is active



For all inputs that are parameterized without cross-circuit monitoring, cross-circuits and short circuits are not detected by the device diagnostics, but only on a change in state of the input signals, as the state only changes in one channel.

**WARNING: Loss of safety function**

An accumulation of errors can result in the loss of the safety function.

- Test the safety function at regular intervals to detect errors at an early stage.

Typical parameterization

| Parameterization | Parameterized as | Comment |
|---|------------------------------------|----------------------|
| Input xx channel 1/channel 2 | | |
| Assignment | Two-channel equivalent | |
| Filter time (t_{Filter}) | 3 ms | Application-specific |
| Symmetry | 100 ms | Application-specific |
| Start inhibit due to symmetry violation | Disabled | Application-specific |
| Cross-circuit monitoring | No cross-circuit monitoring | |

7.4.4 External supply (OSSD)

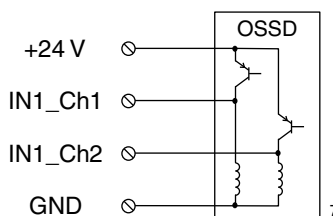


Figure 7-10 Two-channel equivalent assignment of inputs, external supply (OSSD)



WARNING: Loss of safety function

Parasitic voltages can result in the loss of the safety function.

- Connect the sensor ground directly to terminal point GND of the safety module. An external ground may not be used.

Basic specifications

| | |
|------------------------------------|---|
| Sensor | Two-channel OSSD output (with internal testing) |
| Sensor supply | External (OSSD sensor) |
| Achievable safety integrity | SIL 3/SILCL 3/Cat. 4/PL e |

Device diagnostics and behavior of the module in the event of an error



Observe the information to understand the change in state: see see “Example of correct and incorrect signal change” on page 51.

Table 7-7 Two-channel equivalent: external supply (OSSD)

| Error type | Detection | Diagnostics | Loss of SF ¹ | Comment |
|--|-----------|---------------------------------|-------------------------|---|
| Error in the sensor | | | | |
| Channel failure | Yes | Symmetry violation ² | No | The error is detected on a change in state, as the state only changes in one channel. – Change in state from “1” to “0”: The faulty input remains at “1”. A “0” is transmitted in the process data image of the affected inputs. – Change in state from “0” to “1”: A “0” is transmitted in the process data image of the affected inputs, as the faulty input was not previously set to state “0”. |
| Other errors (depending on the sensor) | | | | Please take into consideration errors that can occur in the sensor. |
| Error in the wiring | | | | |
| Interrupt | | | | |
| Input (cable interrupt between sensor and input) | Yes | Symmetry violation ² | No | The error is detected in state “1” or on a change in state from “0” to “1”, as the state only changes in one channel. |
| Input (cable interrupt between sensor and GND) | No | None | No | The error must be detected by the sensor. The sensor must ensure that the safe state is entered in the event of an error. |
| Cross-circuit | | | | |
| Input to input | No | None | Yes | The error must be detected by the sensor. The sensor must ensure that the safe state is entered in the event of an error. |
| Input to clock output | Yes | Symmetry violation ² | No | The error is detected on a change in state if the clock output is set to “1”, as the state only changes in one channel. |
| Short circuit | | | | |
| Input to 24 V | Yes | Symmetry violation ² | No | The error is detected on a change in state, as the state only changes in one channel. |
| Input to ground | Yes | Symmetry violation ² | No | The error is detected in state “1” or on a change in state from “0” to “1”, as the state only changes in one channel. |

¹ SF = safety function

² Only applies when symmetry monitoring is active

AXL F SSDI8/4 1F

Typical parameterization

| Parameterization | Parameterized as | Comment |
|---|------------------------------------|----------------------|
| Input xx channel 1/channel 2 | | |
| Assignment | Two-channel equivalent | |
| Filter time (t_{Filter}) | 3 ms | Application-specific |
| Symmetry | 100 ms | Application-specific |
| Start inhibit due to symmetry violation | Disabled | Application-specific |
| Cross-circuit monitoring | No cross-circuit monitoring | |



Set the filter time for the input to a value greater than the width of the test pulse for the OSSD sensor.
Cross-circuit detection must be disabled.

7.5 Two-channel non-equivalent assignment of safe inputs

For two-channel assignment of the safe inputs, two adjacent inputs of the same connector are always used. This assignment cannot be parameterized: see "Two-channel" on page 36.

For two-channel non-equivalent assignment, the state changes from "0" to "1" only when input INx_Ch1 changes state from "0" to "1" and input INx_Ch2 changes state from "1" to "0". If symmetry monitoring is enabled and the state at both inputs does not change during the parameterized time, a diagnostic message is generated.

The state is active when the state of the signal at channel 1 is equal to "1" and the signal at channel 2 is equal to "0".



Please note that if a delayed change in state at one of the two inputs causes the safety switch to be switched on again, this can result in delayed transmission of state "1" in the process data image of the inputs.

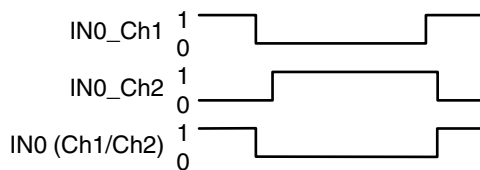
Example of correct and incorrect signal change

Figure 7-11 Correct signal change

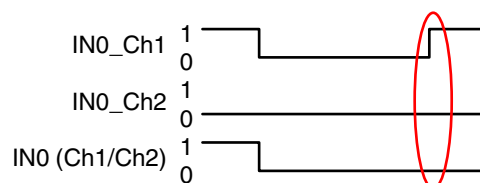


Figure 7-12 Error during signal change

Key for Figure 7-11 and Figure 7-12

| | |
|---------------|--|
| IN0_Ch1 | Signal sequence at input 0 channel 1 |
| IN0_Ch2 | Signal sequence at input 0 channel 2 |
| IN0 (Ch1/Ch2) | Safety-related signal for two-channel input 0, channel 1 and channel 2 at the logic module |

In Figure 7-12, the condition that both signals must be in the opposite state before the change in state is not met. In this case, the diagnostic message is generated.

State evaluation

The module evaluates the states of the inputs and transmits the result to the logic module.

The following values are transmitted in the process data image of the safe inputs:

- “1” if a “1” signal is present at channel 1 of the input and a “0” signal is present at channel 2 of the input **and** no error has been detected and the conditions are met for a change in state according to Figure 7-12.
- “0” is transmitted in all other cases.

7.5.1 Notes on errors

Please observe the following notes on cross-circuit and symmetry violation:

Cross-circuit

The cross-circuit error results in the transmission of the safe state in the process data image of the affected inputs.

- Remove the error and then acknowledge the message.

Acknowledging the diagnostic message deletes the message and activates the input. The states at the input are detected immediately.

- In the safe application program, make sure that the system cannot be restarted unintentionally after acknowledging the diagnostic message.
- Observe the maximum failure detection time of 64 ms.

Exceptions in the failure detection time are indicated in the tables below.

If a “1” signal is present at the input and an error occurs, a maximum of 64 ms elapses until the error is detected. During this time, another “1” can be transmitted, even in the event of an error.

During the failure detection time, the error can cause the state to change unexpectedly from “0” to “1”.

- Make sure that the system cannot be restarted unintentionally as a result of this change in state.

Symmetry violation

- The symmetry violation diagnostic message is only displayed if it was not disabled during parameterization of the affected input.
- **Start inhibit due to symmetry violation disabled:**
The symmetry violation message does **not** result in the transmission of the safe state: see “Symmetry/ start inhibit” on page 37.
The message must be acknowledged. However, the current status of the inputs is always displayed in the process data image of the inputs.
- **Start inhibit due to symmetry violation enabled:**
The symmetry violation message results in the transmission of the safe state: see “Symmetry/ start inhibit” on page 37.
The message must be acknowledged. Following acknowledgment, the current status of the inputs is displayed in the process data image of the inputs.
- The message can be used to monitor the wear of the safety switch.

7.5.2 Cross-circuit monitoring enabled, supply through T1 and T2

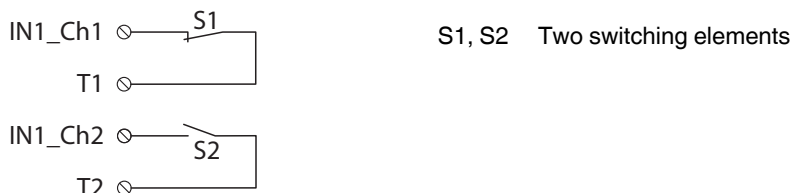


Figure 7-13 Two-channel non-equivalent assignment of inputs, supply through T1 and T2, cross-circuit monitoring enabled

Basic specifications

| | |
|------------------------------------|--|
| Sensor | Two-channel non-equivalent |
| Sensor supply | Internally through clock output T1 and T2, cross-circuit monitoring enabled |
| Achievable safety integrity | SIL 3/SILCL 3/Cat. 4/PL e |



Observe the information to understand the change in state: see see “Example of correct and incorrect signal change” on page 61.

Device diagnostics and behavior of the module in the event of an error

Table 7-8 Two-channel non-equivalent with cross-circuit monitoring: supply through T1 and T2

| Error type | Detection | Diagnostics | Loss of SF ¹ | Comment |
|---|-----------|---------------------------------|-------------------------|---|
| Error in the sensor | | | | |
| A contact fails to open | Yes | Symmetry violation ² | No | The error is detected, as the state only changes in one channel. |
| A contact fails to close | | | | |
| Other errors (depending on the sensor) | | | | Please take into consideration errors that can occur in the sensor. |
| Error in the wiring | | | | |
| Interrupt | | | | |
| Input (cable interrupt between clock output and sensor or between sensor and input) | Yes | Symmetry violation ² | No | The error is detected on a change in state at the latest, as the state only changes in one channel. |
| Cross-circuit | | | | |
| Input to input | Yes | Cross-circuit | No | The error is detected if the other input is set to “1”. |
| Input to assigned clock output | Yes | Symmetry violation ² | No | The error is detected on a change in state, as the state only changes in one channel. |
| Input to non-assigned clock output | Yes | Cross-circuit | No | see “Cross-circuit” on page 62. |
| Clock output to clock output | Yes | Cross-circuit | No | The error is detected for inputs which are assigned to different clock outputs. |
| Short circuit | | | | |
| Input to ground | Yes | None | No | The error is detected on a change in state at the latest, as the state only changes in one channel. |

AXL F SSDI8/4 1F

Table 7-8 Two-channel non-equivalent with cross-circuit monitoring: supply through T1 and T2

| Error type | Detection | Diagnostics | Loss of SF ¹ | Comment |
|------------------------|-----------|---------------|-------------------------|---|
| Clock output to ground | Yes | Short circuit | No | The error is detected on a change in state at the latest, as the state only changes in one channel. The error is also detected as a short circuit of the clock output. The affected clock output is disabled. |

¹ SF = safety function

² Only applies when symmetry monitoring is active



An error in input circuit INx_Ch2 can only be detected in the event of a requested safety function.



WARNING: Loss of safety function

An accumulation of errors can result in the loss of the safety function.

- Test the safety function at regular intervals to detect errors at an early stage.

Typical parameterization

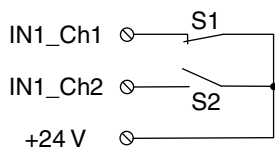
| Parameterization | Parameterized as/value range | Comment |
|---|-----------------------------------|----------------------|
| Input xx channel 1/channel 2 | | |
| Assignment | Two-channel non-equivalent | |
| Filter time (t_{Filter}) | 3 ms | Application-specific |
| Symmetry | Disabled | Application-specific |
| Start inhibit due to symmetry violation | Disabled | Application-specific |
| Cross-circuit monitoring | Cross-circuit monitoring | |

7.5.3 Cross-circuit monitoring disabled, supply through a clock output or external supply



Figure 7-14 Two-channel non-equivalent assignment of inputs, supply through T1 (or T2), cross-circuit monitoring disabled

Connection examples for safe inputs



S1, S2
Two switching elements
+24 V
Supply through external 24 V

Figure 7-15 Two-channel non-equivalent assignment of inputs, external supply

Basic specifications

| | |
|------------------------------------|---|
| Sensor | Two-channel non-equivalent |
| Sensor supply | Internally through clock output T1 (or T2) (clocking disabled) or externally |
| Achievable safety integrity | SIL 3/SILCL 3/Cat. 3/PL d |



Observe the information to understand the change in state: see see “Example of correct and incorrect signal change” on page 61.

Device diagnostics and behavior of the module in the event of an error

Table 7-9 Two-channel non-equivalent without cross-circuit monitoring: supply through a clock output or external supply

| Error type | Detection | Diagnostics | Loss of SF ¹ | Comment |
|---|-----------|---------------------------------|-------------------------|---|
| Error in the sensor | | | | |
| A contact fails to open | Yes | Symmetry violation ² | No | The error is detected, as the state only changes in one channel. |
| A contact fails to close | | | | |
| Other errors (depending on the sensor) | | | | Please take into consideration errors that can occur in the sensor. |
| Error in the wiring | | | | |
| Interrupt | | | | |
| Input (cable interrupt between clock output and sensor or between sensor and input) | Yes | Symmetry violation ² | No | The error is detected on a change in state at the latest, as the state only changes in one channel. |
| Cross-circuit | | | | |
| Input to input | Yes | Symmetry violation ² | No | The error is detected, as the state only changes in one channel. |
| Input to clock output | Yes | Symmetry violation ² | No | The error is detected, as the state only changes in one channel. – Change in state from “1” to “0”: The faulty input remains at “1”. A “0” is transmitted in the process data image of the affected inputs. |
| Clock output to clock output | No | None | No | The error is not detected. |

AXL F SSDI8/4 1F

Table 7-9 Two-channel non-equivalent without cross-circuit monitoring: supply through a clock output or external supply [...]

| Error type | Detection | Diagnostics | Loss of SF ¹ | Comment |
|-------------------------------|-----------|---------------------------------|-------------------------|---|
| Short circuit | | | | |
| Input to external 24 V | Yes | Symmetry violation ² | No | The error is detected on a change in state at the latest, as the state only changes in one channel. |
| Input to ground | Yes | Symmetry violation ² | No | The error is detected in state "1" or on a change in state from "0" to "1", as the state only changes in one channel. |
| Clock output to external 24 V | No | None | No | The error is not detected. |
| Clock output to ground | Yes | Short circuit | No | The error is detected as a change in state from "1" to "0". The error is also detected as a short circuit of the clock output. The affected clock output is disabled. |
| External 24 V to ground | Yes | Symmetry violation ² | No | The error is detected in state "1" or on a change in state from "0" to "1", as the state only changes in one channel. |

¹ SF = safety function

² Only applies when symmetry monitoring is active



WARNING: Loss of safety function

An accumulation of errors can result in the loss of the safety function.

- Test the safety function at regular intervals to detect errors at an early stage.

Typical parameterization

| Parameterization | Parameterized as/value range | Comment |
|---|------------------------------------|----------------------|
| Input xx channel 1/channel 2 | | |
| Assignment | Two-channel non-equivalent | |
| Filter time (t_{Filter}) | 3 ms | Application-specific |
| Symmetry | 100 ms | Application-specific |
| Start inhibit due to symmetry violation | Enabled | Application-specific |
| Cross-circuit monitoring | No cross-circuit monitoring | |

8 Startup and validation

8.1 Initial startup

Table 8-1 Steps for startup

| Step | Relevant section and literature |
|---|--|
| Set the address. | "Setting the DIP switch" on page 30 |
| Install the module in the Axioline F station. | "Assembly, removal, and electrical installation" on page 29 UM EN AXL F SYS INST user manual |
| Connect the bus system and supply voltage cables to the Axioline F station. | UM EN AXL F SYS INST user manual or documentation for the bus coupler |
| Wire the inputs according to your application. | "Connection examples for safe inputs" on page 41 |
| Before applying the operating voltage: <ul style="list-style-type: none"> – Make sure that there are no wiring errors (e.g., cross-circuit or short circuit) or grounding errors by testing with a multimeter. – Make sure that functional earth ground is connected. | |
| Connect the necessary voltages to the Axioline F module. | UM EN AXL F SYS INST user manual or documentation for the module |
| Once the operating voltage has been applied: <ul style="list-style-type: none"> – If possible, measure the waveform of the voltages to make sure that there are no deviations. – Measure the input voltages on the module to make sure that they are in the permissible range. – Use the LEDs on the module to check that the module starts up without any errors. | |
| Check the assembly and installation. | Checklist: see Appendix A 2 "Assembly and electrical installation" |
| Carry out the necessary parameterization. | "Parameterization of the module" on page 35 Documentation for the logic module used (SafetyBridge) |
| Program the safety function. | Online help for the SAFECONF configuration software |
| Perform a function test and validation. Check whether the safety function responds as planned during programming and parameterization. | Checklist: see Appendix A 4 "Validation" |
| When connecting the supply voltages, use the diagnostics and status indicators to check whether the module has started up correctly or whether any errors are indicated. | Instructions on how to proceed in the event of an error: see "Errors: messages and removal" on page 71 |

8.1.1 Startup mode

**WARNING: Risk due to standard operation**

The module is **not** safe in startup mode, as all partial safety functions are deactivated. Unintentional system states or incorrect responses cannot be ruled out.

- Do not enter any danger zones and make sure that no other persons can access the danger zone either.

The device features a startup mode in which the Startup+ software can be used to perform the following functions:

- Wiring check
- Read inputs
- Read and acknowledge diagnostic messages

Startup mode is set using the DIP switch on the top of the module, see Section 4.1.3 “Setting the DIP switch” on page 30.

To enter startup mode, proceed as follows:

1. Set position 11 of the DIP switch to “on”.
2. Carry out a power up.

The red CM LED indicates that the device is in startup mode.

3. In the Startup+ software, enter the address set on the device.



For additional information on the Startup+ software, refer to the documentation for the software.

The software can be downloaded free of charge at phoenixcontact.net/products.

8.2 Restart after replacing a module

8.2.1 Replacing a module



WARNING: Unintentional machine startup

Make sure that the power to the system is disconnected before carrying out assembly and removal work as this could cause unintentional machine startup.

- Before assembling or removing the module, disconnect the power to the module and the entire Axioline F station and make sure that the system cannot be switched on again.
- Make sure the entire system is reassembled before switching the power back on and that neither the station nor the system poses a hazard.
Observe the diagnostics indicators and any diagnostic messages.

If replacing a module, proceed as described for assembly and removal: see Section 4 “Assembly, removal, and electrical installation” on page 29 or Axioline F: system and installation user manual, UM EN AXL F SYS INST.

- Install the new module at the correct position in the station.
- Observe the color coding of the connector/slot when mounting the connectors.

The new module must meet the following requirements:

- Same device type
- Same or later version

8.2.2 Restart

Once the module has been replaced, proceed as described for initial startup: see Section 8.1 “Initial startup” on page 67.

The parameterization of the previous module remains the same and is transmitted to the new module when the system is started.

8.3 Validation

Carry out a safety validation every time you make a safety-related modification.

- When validating your EUC, check the assignment of the individual sensor connections.
- Make sure that the following requirements are met:
 - The correct safe sensors are connected to the module.
 - The parameterization of the module is correct.
 - The variables used in your application program have been linked to the safe sensors correctly.
- Perform a function test and error simulation.

Observe the information on validation provided in the checklist: see Section A 4 “Validation” on page 89.

AXL F SSDI8/4 1F

9 Errors: messages and removal

9.1 Displaying and reading errors

Diagnostics indicators and diagnostic messages

Depending on the error type, errors that are diagnosed are displayed via the local diagnostics indicators and/or transmitted to the logic module as diagnostic messages.

Depending on the controller, the SafetyBridge function blocks provide error codes. In order to determine what type of error has occurred, use the corresponding software to access the standard controller online and read the error.

Please also refer to the documentation for the logic module used.

9.2 Acknowledging an error

Acknowledgment

An AXL F SSDI8/4 1F error is acknowledged completely via the “Operate” function block.



WARNING: Acknowledgment may result in a hazardous system state

With the exception of a few special cases, the acknowledgment of an error immediately returns the safe input or output to the operating state.

- Before acknowledging an error you must therefore make sure that the acknowledgment will not cause the machine to switch to a hazardous state.
- When planning the machine or system, make sure that acknowledgment is only possible if the danger zone is visible.



For instructions on error acknowledgment, please refer to the documentation for the logic module used.

9.3 Module replacement following an error

If the safety module is replaced in the event of an error, proceed as described in “Assembly, removal, and electrical installation” on page 29 and “Restart after replacing a module” on page 69.

9.4 Note about the error codes

Error cause and error location

The error code of a diagnostic message consists of the code for the error cause and the code for the error location.

Refer to the examples below for an explanation of the error codes.

Table 9-1 Examples explaining the error codes

Higher-level error code;
x = error location

Detailed error code with
error location

Error location: input
and channel

YYY = not relevant

| Error code (hex) | Error location | LED | Error cause Error description | Effect | Solution Acknowledgment |
|------------------------------------|---------------------------|----------|--|--------|----------------------------|
| 012x 0120 ... 012B | IN0_Ch1 ... IN3_Ch2 | SD on | Cross-circuit ... | ... | ... |
| 018x 0180 | IN0_Ch1&2 | SD on | Error during signal change ... | ... | ... |
| 4YYY | - | | No error - SafetyBridge address is displayed | ... | ... |

Additional information about the error, possible solutions, and acknowledgment behavior.

Examples from Table 9-1:

0120: cross-circuit at IN0_Ch1 (input 0 channel 1)

0180: error during signal change at IN0_Ch1&2 (input 0 channel 1 and 2)

4021: no error; the SafetyBridge address is displayed

The error codes are listed in ascending order in Table 9-2 "Error codes".



If error codes are indicated by the system which do not appear in the table, please contact Phoenix Contact.

9.5 Error codes

Table 9-2 Error codes

| Error code (hex) | Error location | LED | Error cause Error description | Effect | Solution Acknowledgment |
|---|--|-------|---|--|--|
| 012x 0120 0121 0122 0123 0128 0129 012A 012B | IN0_Ch1 IN1_Ch1 IN2_Ch1 IN3_Ch1 IN0_Ch2 IN1_Ch2 IN2_Ch2 IN3_Ch2 | SD on | Cross-circuit <ul style="list-style-type: none"> – With another input or with a clock output | Affected input is in the safe state | 1. Check sensor 2. Check clock outputs 3. Check connector and cabling Acknowledgment: Acknowledgment deletes the message and activates the input. ⚠ The states at the input are detected immediately. |
| 013x 0130 0131 0132 0133 | IN0_Ch1&2 IN1_Ch1&2 IN2_Ch1&2 IN3_Ch1&2 | SD on | Symmetry violation <ul style="list-style-type: none"> – Not safety-related – Only for inputs parameterized for two-channel operation – Used to evaluate the contacts of connected switches – State change in both channels takes longer than the value parameterized for symmetry <p>Message can also be triggered by a cross-circuit/short circuit</p> | <p>“Start inhibit due to symmetry violation” is disabled:</p> <ul style="list-style-type: none"> – Inputs continue to be detected and their states transmitted to the logic module <p>“Start inhibit due to symmetry violation” is enabled:</p> <ul style="list-style-type: none"> – Affected input is in the safe state | 1. Check whether the message was triggered by a short circuit/cross-circuit If not: <ol style="list-style-type: none"> 1. Check value for symmetry 2. Check switches 3. Replace switches during next maintenance 4. Activate connected I/O devices once (e.g., activate and unlock emergency stop) <p>Acknowledgment:</p> <p>“Start inhibit due to symmetry violation” is disabled:</p> <ul style="list-style-type: none"> – Acknowledgment deletes the message. <p>“Start inhibit due to symmetry violation” is enabled:</p> <ul style="list-style-type: none"> – Acknowledgment deletes the message and activates the input. ⚠ The states at the input are detected immediately. |

AXL F SSDI8/4 1F

Table 9-2 Error codes

| Error code (hex) | Error location | LED | Error cause Error description | Effect | Solution Acknowledgment |
|---|--|----------------------|--|---|---|
| 014x 0140 0141 0142 0143 0148 0149 014A 014B | IN0_Ch1 IN1_Ch1 IN2_Ch1 IN3_Ch1 IN0_Ch2 IN1_Ch2 IN2_Ch2 IN3_Ch2 | SD on | Hardware fault | All module inputs are in the safe state | 1. Perform power up (with selftest) If the selftest following power up is not error-free: 2. Replace module Acknowledgment: Acknowledgment deletes the message. Restart is only possible following power up and error-free selftest. |
| 0170 | - | SD on | | | |
| 018x 0180 0181 0182 0183 | IN0_Ch1&2 IN1_Ch1&2 IN2_Ch1&2 IN3_Ch1&2 | SD on | Error during signal change – Only for inputs parameterized for two-channel operation – Implausible signal change at indicated input pair | Affected inputs in the safe state | 1. Set both inputs to the safe state Acknowledgment: Acknowledgment deletes the message. |
| 01Ex 01E0 01E8 | Clock output T1 Clock output T2 | SD on | Short circuit or overload – The clock outputs are also switched on and monitored when not parameterized. If a short circuit occurs at a clock output when it is in this state, the clock output is switched off. | Affected clock output is disabled Assigned inputs are set to "0" | Module parameterized: 1. Check connector and cabling 2. If necessary, acknowledge error at all inputs Module not parameterized: 1. Carry out parameterization Acknowledgment: Acknowledgment deletes the message and activates the clock output and the assigned inputs. Δ The states at the input are detected immediately. |
| 01F0 | - | UI flashing SD on | Undervoltage U_1 – Supply voltage is below the permissible voltage range – If $U_1 < 17$ V, a diagnostic message is generated | All module inputs are in the safe state | 1. Check supply voltage level and correct 2. Check supply line length and load Acknowledgment: Acknowledgment deletes the message and activates the input. Δ The states at the input are detected immediately. |

Table 9-2 Error codes

| Error code (hex) | Error location | LED | Error cause Error description | Effect | Solution Acknowledgment |
|---|--|-------------|--|---|--|
| 01F2 | - | SD on | Critical device temperature | Immediate shutdown. A further temperature increase causes the module to switch to the safe state. | Check and adapt the following if necessary: <ul style="list-style-type: none"> - Ambient conditions - Derating - Switching frequency Acknowledgment: Acknowledgment deletes the message. |
| 034x 0340 0341 0342 0343 | IN0_Ch1&2 IN1_Ch1&2 IN2_Ch1&2 IN3_Ch1&2 | FS flashing | Incorrect parameterization <ul style="list-style-type: none"> - Symmetry monitoring has been parameterized, even though single-channel operation is used for the input pair | Module is in the safe state | 1. Disable symmetry monitoring or parameterize two-channel operation 2. Resend parameter data to the module (deactivate/activate "Operate" block) Acknowledgment: not possible |
| 035x 0350 0351 0352 0353 | IN0_Ch1&2 IN1_Ch1&2 IN2_Ch1&2 IN3_Ch1&2 | FS flashing | Incorrect parameterization <ul style="list-style-type: none"> - "Start inhibit due to symmetry violation" has been parameterized and single-channel operation is used for the input pair and/or <ul style="list-style-type: none"> - Symmetry monitoring is not activated | Module is in the safe state | Single-channel assignment: <ol style="list-style-type: none"> 1. Deactivate start inhibit due to symmetry violation 2. Resend parameter data to the module (deactivate/activate "Operate" block) Two-channel assignment: <ol style="list-style-type: none"> 1. Activate symmetry monitoring 2. Resend parameter data to the module (deactivate/activate "Operate" block) Acknowledgment: not possible |
| 0440 | - | SD on | Incorrect SafetyBridge address <ul style="list-style-type: none"> - The parameterized SafetyBridge address does not match the address set on the safety module | Module is in the safe state | 1. Deactivate the "Operate" block. 2. See message "4YYY" on page 76. Acknowledgment: not possible |

AXL F SSDI8/4 1F

Table 9-2 Error codes

| Error code (hex) | Error location | LED | Error cause Error description | Effect | Solution Acknowledgment |
|---------------------|----------------|-------------|---|-----------------------------|--|
| 0441 ... 0446 | - | SD on | Internal error | Module is in the safe state | Please contact Phoenix Contact. Acknowledgment: not possible |
| 0447 | - | SD on | Incorrect configuration and parameter data record – The device detected an error in the configuration and parameter data record | Module is in the safe state | 1. Resend parameter data to the module (deactivate/activate “Operate” block) If the error occurs permanently: 2. Generate new data record in SAFECNF Acknowledgment: not possible |
| 109A | - | FS on | DIP switch moved during operation | Module is in the safe state | 1. Check DIP switch position and bring in line with SAFECNF project 2. Perform power up Acknowledgment: Not possible. Restart is only possible following power up and error-free selftest. |
| 1YYY | - | FS on | Internal error | Module is in the safe state | Please contact Phoenix Contact. Acknowledgment: not possible |
| 4YYY | - | FS flashing | No error – “Operate” block has been deactivated – SafetyBridge address is displayed | Module is in the safe state | 1. Check DIP switch position and bring in line with SAFECNF project See Table 4-1 on page 30 and documentation for the logic module. 2. Activate “Operate” block |
| 8000 | - | P on | No error | - | - |

10 Maintenance, repair, decommissioning, and disposal

10.1 Maintenance

The module does not require maintenance. Depending on the application and connected I/O devices, the function of the I/O devices and the safety chain must be tested regularly.

The duration of use of the module is 20 years, or 25 years with a low demand rate.

Repeat testing during this time is not required.

- Carry out maintenance on connected I/O devices (e.g., light grid) according to the manufacturer specifications.

10.2 Repair

It is prohibited for the user to carry out repair work or make modifications to the module. The housing must not be opened. The module is protected against tampering by means of security labels. The security label is damaged in the event of unauthorized repairs or opening of the housing. In this case, the correct operation of the safety module can no longer be ensured.

- In the event of an error, send the module to Phoenix Contact or contact Phoenix Contact immediately and engage a service engineer.

10.3 Decommissioning and disposal

Carry out decommissioning according to the requirements of the machine or system manufacturer.

When decommissioning the system or parts of the system, ensure the following for the modules used:

| Fate of the module | Measure |
|---|---|
| The modules will continue to be used correctly. | Observe the storage and transport requirements according to the technical data: see Section 11.2 "AXL F SSDI8/4 1F module data" on page 79. |
| Modules will no longer be used. | Dispose of modules in accordance with the environmental regulations. Make sure that the modules can never be reused. |



AXL F SSDI8/4 1F

11 Technical data and ordering data

11.1 SafetyBridge system data

For the system data for the SafetyBridge system, please refer to the documentation for the logic module.

11.2 AXL F SSDI8/4 1F module data

| General data | |
|---|---|
| Housing dimensions without bus base module with connector (width x height x depth) | 53.6 mm x 126.1 mm x 54 mm |
| Weight (with connectors) | 220 g, approximately |
| Operating mode | |
| SafetyBridge | Process data mode with 4 words |
| Ambient temperature | |
| Operation | -35°C to +60°C (any mounting position) |
| Storage/transport | -40°C to +85°C |
| Humidity | |
| Operation | 75% on average, 85% occasionally (non-condensing) |
| <div style="border: 1px solid black; padding: 5px;">  Measures against increased humidity must be taken. </div> | |
| Storage/transport: | 75% (non-condensing) |
| <div style="border: 1px solid black; padding: 5px;">  For a short period, slight condensation may appear on the outside of the housing. </div> | |
| Air pressure | |
| Operation | 70 kPa to 108 kPa (up to 3000 m above sea level) |
| Storage/transport | 66 kPa to 108 kPa (up to 3500 m above sea level) |
| Degree of protection | IP20; operation in at least IP54 installation space |
| Housing material | Plastic PBT, self-extinguishing (V0) |
| Air clearances and creepage distances | According to IEC 60664-1 |
| Protection class | III (PELV) |
| Gases that may endanger functions according to DIN 40046-36, DIN 40046-37 | Not resistant to gas that may endanger functions (sulfur dioxide (SO ₂), hydrogen sulfide (H ₂ S)) |
| Resistance of the housing material to fungal decay | Resistant |
| Ambient compatibility | Not resistant to organic chlorine compounds |

AXL F SSDI8/4 1F

| General data [...] | |
|---|---|
| Connection data for Axioline F connectors | |
| Connection method | Spring-cage terminal blocks |
| Conductor cross section | Solid: 0.5 mm ² to 1.5 mm ² Flexible without sleeve: 0.25 mm ² to 1.5 mm ² Flexible with sleeve: 0.25 mm ² to 1.5 mm ² 24 - 16 AWG |



UL note:
Use copper wire that is approved up to 75°C.

Mechanical requirements

| | |
|--------------------------------------|---|
| Vibration according to IEC 60068-2-6 | 10 - 57 Hz: 0.35 mm with constant amplitude 57 - 150 Hz: 5g acceleration, constant amplitude |
| Shock according to IEC 60068-2-27 | 30g over 11 ms, Criterion A |

Safety characteristics according to EN 61508

| | |
|---|--|
| Achievable SIL | SIL 2 (single-channel) SIL 3 (two-channel) Depends on the parameterization and wiring; see Section 2.6 "Connection options for sensors depending on the parameterization" on page 18, see Section 7 "Connection examples for safe inputs" on page 41 |
| Probability of a dangerous failure on demand by the safety function (PFD) | |
| For single-channel assignment | 1% of 10 ⁻² , maximum (corresponds to 1 x 10 ⁻⁴) |
| For two-channel assignment | 1% of 10 ⁻³ , maximum (corresponds to 1 x 10 ⁻⁵) |
| Probability of a dangerous failure per hour for the entire module (PFH) | Depends on the parameterization |
| For single-channel assignment | 1% of 10 ⁻⁶ , maximum (corresponds to 1 x 10 ⁻⁸) |
| For two-channel assignment | 1% of 10 ⁻⁷ , maximum (corresponds to 1 x 10 ⁻⁹) |
| Hardware fault tolerance (HFT) of the module | 1 |
| Permissible duration of use | 20 years, 25 years with a low demand rate |

Safety characteristics according to EN 62061

| | |
|---|--|
| Achievable SIL claim limit | SILCL 2 (single-channel) SILCL 3 (two-channel) Depends on the parameterization and wiring; see Section 2.6 "Connection options for sensors depending on the parameterization" on page 18, see Section 7 "Connection examples for safe inputs" on page 41 |
| Safe failure fraction (SFF) | 99% |
| Probability of a dangerous failure per hour for the entire module (PFH) | Depends on the parameterization |
| For single-channel assignment | 1% of 10 ⁻⁶ , maximum (corresponds to 1 x 10 ⁻⁸) |
| For two-channel assignment | 1% of 10 ⁻⁷ , maximum (corresponds to 1 x 10 ⁻⁹) |
| Hardware fault tolerance (HFT) of the module | 1 |
| Permissible duration of use | 20 years, 25 years with a low demand rate Operation in the error state: 72 h |

Technical data and ordering data

Safety characteristics according to EN ISO 13849-1

| | |
|--|--|
| Achievable performance level | PL d (single-channel) PL e (two-channel) Depends on the parameterization and wiring: see Section 2.6 "Connection options for sensors depending on the parameterization" on page 18, see Section 7 "Connection examples for safe inputs" on page 41 |
| Diagnostic coverage (DC) | 99% |
| Mean time to dangerous failure (MTTFd) | 100 years (regardless of whether single-channel or two-channel assignment) |

Supply voltage U_{BUS} (logic)



The bus coupler or a feed-in terminal in the station supply the module with communications power U_{BUS} .
For the technical data, please refer to the data sheet for the bus coupler or the feed-in terminal.

| | |
|------------------------------------|--|
| Communications power | 5 V DC |
| Current consumption from U_{BUS} | 280 mA, typical (all inputs set; supply by U_1 of 19.2 V DC to 30.2 V DC) 310 mA, maximum |

Supply voltage U_1 (sensors, clock outputs, I/O)



WARNING: Loss of safety function

The use of unsuitable power supplies can result in the loss of the safety function.

- Use power supplies according to EN 50178/VDE 0160 (PELV).

| | |
|--------------------------------------|---|
| Nominal voltage | 24 V DC according to EN 61131-2 and EN 60204 |
| Ripple | 3.6 V _{PP} |
| Permissible voltage range | 19.2 V DC to 30.2 V DC (including all tolerances, ripple included) |
| Current consumption | 9 mA, typical (all inputs set; supply by U_1 with 30.2 V DC; without supply to the sensors via clock supplies T1 and T2) |
| Permissible interrupt time | 1 ms (output voltage of the clock outputs can fail) |
| Surge protection | Yes |
| Protection against polarity reversal | Parallel protection against polarity reversal for a limited period |



NOTE: Module damage

Parallel protection against polarity reversal is only implemented in the module for a limited period. The following measures must be taken to prevent damage to the module:

- Due to the maximum current carrying capacity of 8 A, protect power supply U_1 externally with an 8 AT fuse.
- Only use PELV power supply units with at least four times the nominal tripping current, as this is the only way to ensure tripping times of less than 300 ms.

| | |
|------------------------|---|
| Undervoltage detection | At 16.6 V |
| Diagnostics indicators | Green U_1 LED see Section 2.7 "Local diagnostics and status indicators" on page 19 |
| External protection | 8 A slow-blow, maximum |

Safe digital inputs

| | |
|-------------------------------------|--|
| Quantity | 4 two-channel or 8 single-channel |
| Input design | According to the requirements of EN 61131-2 Type 3 |
| Supply | Via clock outputs T1 and T2 or external supply |
| Input current | Approximately 4.2 mA at 24 V, typical |
| Maximum permissible current for "0" | 2 mA |

AXL F SSDI8/4 1F

| Safe digital inputs [...] | |
|-------------------------------------|--|
| Minimum permissible current for "1" | 2.5 mA |
| Permissible input voltage range | -3 V to +30.2 V |
| Voltage range for "0" | -3 V to +5 V |
| Voltage range for "1" | 11 V to 30 V |
| Maximum switching frequency | 10 Hz |
| Filter time t_{Filter} | 1.5/3/5/15 ms (can be parameterized): see "Filter time (t_{Filter})" on page 36 |
| Accuracy of filter time | +0 ms, -0.5 ms |
| Processing time of the input | $t_{IN} = t_{Filter} + t_{FW}$ See "Processing time of input t_{IN} in the event of a safety demand" on page 38 |
| Simultaneity | 100% |
| Symmetry evaluation | Yes, can be parameterized, accuracy $\pm 20\%$ |
| Derating | No |
| Permissible cable lengths | 1000 m from clock output to safe input (total length of the connected cables) |
| Status indicators | One green LED per input see Section 2.7 "Local diagnostics and status indicators" on page 19 |



The switching state of the inputs is constantly monitored. In the event of an error, e.g., if a component fails, the error is reported to the logic module.

Clock outputs

| | |
|-------------------------------------|--|
| Quantity | 2 |
| Supply | From U_1 |
| Limiting continuous current (total) | 0.4 A short-circuit and overload protection |
| Saturation voltage | $U_1 - 1$ V |
| Simultaneity | 100% |
| Derating | No |
| Permissible cable lengths | The total length of the connected cables must not exceed 1000 m per clock output |
| Status indicators | None |

Approvals

For the latest approvals, please visit phoenixcontact.net/products.

11.3 Conformance with EMC Directive

Conformance with EMC Directive 2014/30/EU

Noise immunity test according to DIN EN 61000-6-2

| | | |
|---------------------------------|---------------------------------|--|
| Electrostatic discharge (ESD) | EN 61000-4-2 (IEC 61000-4-2) | Criterion A 6 kV contact discharge, 8 kV air discharge |
| Electromagnetic fields | EN 61000-4-3 (IEC 61000-4-3) | Criterion A, field strength 10 V/m |
| Fast transients (burst) | EN 61000-4-4 (IEC 61000-4-4) | Criterion A, test voltage 2 kV |
| Transient overvoltage (surge) | EN 61000-4-5 (IEC 61000-4-5) | Test intensity 2, Criterion A DC supply lines: 1.0 kV/1.0 kV (symmetrical/asymmetrical) Signal lines: 1.0 kV/2.0 kV (symmetrical/asymmetrical) |
| Conducted disturbance variables | EN 61000-4-6 (IEC 61000-4-6) | Criterion A, test voltage 10 V |

Noise emission test according to DIN EN 61000-6-3

| | | |
|----------------|----------|----------------------|
| Noise emission | EN 55022 | Class B, residential |
|----------------|----------|----------------------|

11.4 Ordering data: module

| Description | Type | Order No. | Pcs./Pkt. |
|--|------------------|-----------|-----------|
| Axioline F module with safe digital inputs | AXL F SSDI8/4 1F | 2702263 | 1 |

11.5 Download data: software



Make sure you always use the latest software. The software can be downloaded free of charge at phoenixcontact.net/products.

| Description | Type | Download area for Order No. |
|--|----------|-----------------------------|
| SAFECONF | | |
| Configuration software for SafetyBridge technology and Trisafe modules | SAFECONF | 2986119 |
| STARTUP+ | | |
| Software for starting up and parameterizing Axioline stations | STARTUP+ | 2700636 |

11.6 Download data: documentation



Make sure you always use the latest documentation. It can be found in the download area for the specified product at phoenixcontact.net/products.

| Description | Type | Download area for Order No. |
|--|---|-----------------------------|
| Axioline F | | |
| User manual Axioline F: system and installation | UM EN AXL F SYS INST | 2702263 |
| User manual Axioline F: diagnostic registers and error messages | UM EN AXL F SYS DIAG | 2702263 |
| SafetyBridge | | |
| User manual: Axioline F module with integrated safety logic and safe digital outputs | UM EN AXL F LPSD08/3 1F | 2702171 |
| SafetyBridge technology integration package for controllers from Phoenix Contact, Rockwell and Siemens (S7-1200 as of CPU 1214C, S7-1500, S7-300), Schneider as well as CODESYS-based controllers. | SBT_V3_PLC_Integration_Packages_1.8.exe | 2702171 |



The SafetyBridge V3 integration package contains various quick start guides for integrating the SafetyBridge system with different controllers.

A Appendix: checklists

The checklists listed in this section provide support when carrying out the following tasks on the AXL F SSDI8/4 1F module: planning, assembly and electrical installation, startup, parameterization, and validation.



These checklists may be used as planning documentation and/or as verification to ensure the steps in the specified phases are carried out carefully.

Archive the completed checklists to use as reference for recurring tests.

The checklists do not replace the validation, initial startup, and regular testing performed by qualified personnel.

The following section of a checklist shows an example of a completed checklist.

| Checklist ... | | | | |
|---|--|---------------------------|--------------------------|---------|
| Device type/equipment identification | | AXL F SSDI8/4 1F/BK20NA10 | | |
| Version: HW/FW | 00/101 | Date | 2008-01-17 | |
| Test engineer 1 | John Smith | Test engineer 2 | Jane Brown | |
| Comment | System XXX has been checked for engine hood production | | | |
| No. | Requirement (mandatory) | Yes | | Comment |
| X | ... | <input type="checkbox"/> | | |
| No. | Requirement (optional) | Yes | No | Comment |
| Y | ... | <input type="checkbox"/> | <input type="checkbox"/> | |

Key:

| | |
|--------------------------|---|
| Equipment identification | Enter the device type and/or the equipment identification for the relevant module. |
| Version: HW/FW | Enter the hardware and firmware version of the module. |
| Date | Enter the date on which you began to fill in this checklist. |
| Editor | Enter the name of the editor. |
| Test engineer | Enter the name of the test engineer. |
| Comment | Where necessary, enter a comment. |
| Requirement (mandatory) | These requirements must be met for a safety application, in order to complete the relevant phase using the checklist. |
| Requirement (optional) | These requirements are optional. For points that are not met, please enter a comment. |

AXL F SSDI8/4 1F

A 1 Planning

| Checklist for planning the use of the module | | | | |
|--|---|--------------------------|--------------------------|---------------------------|
| Device type/equipment identification | | | | |
| Version: HW/FW | | Date | | |
| Test engineer 1 | | Test engineer 2 | | |
| Comment | | | | |
| No. | Requirement (mandatory) | Yes | Comment | |
| 1 | Has the current module user manual been used as the basis for planning? | <input type="checkbox"/> | Revision: | |
| 2 | Are the sensors approved for connection to the module (according to the technical data and parameterization options)? | <input type="checkbox"/> | | |
| 3 | Has the power supply been planned according to the specifications for the protective extra-low voltage in accordance with PELV? | <input type="checkbox"/> | | |
| 4 | Is external protection of the module planned (according to the specifications in this user manual for supply voltage U_i)? | <input type="checkbox"/> | | |
| 5 | Are measures planned to prevent simple tampering? | <input type="checkbox"/> | | |
| 6 | Are measures planned to prevent connectors being mixed up? | <input type="checkbox"/> | | |
| 7 | Are requirements for the sensors and cable installation observed according to the SIL/SILCL/Cat./PL to be achieved and is the implementation planned? | <input type="checkbox"/> | | |
| 8 | Are the specifications for the parameterization for each channel defined? | <input type="checkbox"/> | | |
| 9 | Has it been ensured that any person intentionally starting hazardous movements can only do so with a direct view of the danger zone? | <input type="checkbox"/> | | |
| 10 | Does the planned use correspond to the intended use? | <input type="checkbox"/> | | |
| 11 | Are the ambient conditions as well as the maximum mechanical load observed according to the technical data? | <input type="checkbox"/> | | |
| 12 | Have test intervals been defined and has the maximum duration of use been taken into consideration? | <input type="checkbox"/> | | |
| No. | Requirement (optional) | Yes | No | Comment |
| 13 | Have the accessories to be used been planned according to the ordering data in this user manual (cables, connectors)? | <input type="checkbox"/> | <input type="checkbox"/> | |
| 14 | Have specifications for assembly and electrical installation been defined (e.g., EPLAN) and communicated to the relevant personnel? | <input type="checkbox"/> | <input type="checkbox"/> | |
| 15 | Have specifications for startup been defined and communicated to the relevant personnel? | <input type="checkbox"/> | <input type="checkbox"/> | |
| | | Date | | Signature (editor) |
| | | Date | | Signature (test engineer) |

A 2 Assembly and electrical installation

Checklist for assembly and electrical installation of the module

| | | | |
|---|--|--------------------------|---------------------------|
| Checklist for assembly and electrical installation of the module | | | |
| Device type/equipment identification | | | |
| Version: HW/FW | | Date | |
| Test engineer 1 | | Test engineer 2 | |
| Comment | | | |
| No. | Requirement (mandatory) | Yes | Comment |
| 1 | Was assembly completed according to the specifications (specifications from the planning phase or according to the user manual)? | <input type="checkbox"/> | |
| 2 | Was the module installed in the control cabinet (IP54) and secured correctly? | <input type="checkbox"/> | |
| 3 | Do the cable cross sections and installations correspond to the specifications? | <input type="checkbox"/> | |
| 4 | Does the connection technology correspond to the specifications in the technical data and in the relevant user manual? | <input type="checkbox"/> | |
| 5 | Is the address switch set correctly according to the specifications? | <input type="checkbox"/> | |
| | | Date | Signature (editor) |
| | | Date | Signature (test engineer) |

AXL F SSDI8/4 1F

A 3 Startup and parameterization

| Checklist for startup and parameterization of the module | | | | |
|--|--|--------------------------|---------------------------|---------|
| Device type/equipment identification | | | | |
| Version: HW/FW | | Date | | |
| Test engineer 1 | | Test engineer 2 | | |
| Comment | | | | |
| No. | Requirement (mandatory) | Yes | Comment | |
| 1 | Was startup completed according to the specifications (specifications from the planning phase or according to the user manual)? | <input type="checkbox"/> | | |
| 2 | During startup, is it ensured that any person starting hazardous movements intentionally can only do so with a direct view of the danger zone? | <input type="checkbox"/> | | |
| 3 | Are all parameters parameterized for the inputs and is the F_WD_Time set correctly? | <input type="checkbox"/> | | |
| 4 | For inputs that are parameterized for two-channel operation, are both channels parameterized correctly for each other? | <input type="checkbox"/> | | |
| 5 | Is the assignment to the clock outputs parameterized for the inputs? | <input type="checkbox"/> | | |
| 6 | Are the clock outputs parameterized? | <input type="checkbox"/> | | |
| No. | Requirement (optional) | Yes | No | Comment |
| 7 | Have safety distances that must be observed been calculated according to the response and delay times implemented? | <input type="checkbox"/> | <input type="checkbox"/> | |
| | | Date | Signature (editor) | |
| | | Date | Signature (test engineer) | |

A 4 Validation

| Checklist for validating the module | | | |
|--------------------------------------|--|--------------------------|---------------------------|
| Device type/equipment identification | | | |
| Version: HW/FW | | Date | |
| Test engineer 1 | | Test engineer 2 | |
| Comment | | | |
| No. | Requirement (mandatory) | Yes | Comment |
| 1 | Have all the mandatory requirements for the "Planning" checklist been met? | <input type="checkbox"/> | |
| 2 | Have all the mandatory requirements for the "Assembly and electrical installation" checklist been met? | <input type="checkbox"/> | |
| 3 | Have all the mandatory requirements for the "Startup and parameterization" checklist been met? | <input type="checkbox"/> | |
| 4 | Does the parameterization of the safe inputs and clock outputs correspond to the version and the actual connection of the controlling devices? | <input type="checkbox"/> | |
| 5 | Has the assignment of the sensors to the inputs and the variables of the safe application program been tested (online status in SafetyProg)? | <input type="checkbox"/> | |
| 6 | Has a function test been performed to check all safety functions in which the module is involved? | <input type="checkbox"/> | |
| 7 | Have measures been taken to achieve a specific Cat.? | <input type="checkbox"/> | |
| 8 | Do all cables correspond to the specifications? | <input type="checkbox"/> | |
| 9 | Does the power supply correspond to the specifications for the protective extra-low voltage in accordance with PELV? | <input type="checkbox"/> | |
| 10 | Is external protection of the module implemented (according to the specifications in this user manual for supply voltage U_I)? | <input type="checkbox"/> | |
| 11 | Have measures been taken to prevent simple tampering? | <input type="checkbox"/> | |
| 12 | Are requirements for the sensors and cable installation observed according to the SIL/SILCL/Cat./PL to be achieved? | <input type="checkbox"/> | |
| 13 | Are the specifications for the parameterization for each channel implemented? | <input type="checkbox"/> | |
| 14 | Has it been ensured that any person intentionally starting hazardous movements can only do so with a direct view of the danger zone? | <input type="checkbox"/> | |
| | | Date | Signature (editor) |
| | | Date | Signature (test engineer) |

AXL F SSDI8/4 1F

B Appendix: index

A

| | |
|--------------------------|----|
| Abbreviations | 12 |
| Artikel-Nummer | 83 |
| Assembly | 31 |
| Bus base module..... | 31 |
| Connector..... | 32 |
| Electronics module | 31 |
| Instructions..... | 29 |
| Location..... | 29 |
| Assignment | 36 |
| Single-channel | 44 |
| Two-channel..... | 50 |

B

| | |
|---------------------|----|
| Bouncing time | 37 |
|---------------------|----|

C

| | |
|--------------------------------------|------------|
| Clocking | 17 |
| Conformance with EMC Directive | 83 |
| Cross | 17 |
| Cross-circuit monitoring | |
| Disabled | 46, 55, 64 |
| Enabled | 44, 53, 63 |
| Current carrying capacity | 25, 26 |

D

| | |
|-------------------------------|----|
| DC distribution network | 26 |
| Decommissioning | 77 |
| Device errors | |
| Inputs | 22 |
| Serious errors..... | 22 |
| Diagnostics indicators | 19 |
| Directives | 11 |
| Disposal | 77 |

E

| | |
|----------------------------|----|
| Error codes (table) | 73 |
| Errors | |
| Acknowledgment..... | 71 |
| Messages and removal | 71 |

F

| | |
|------------------------|----|
| Failure state | 22 |
| Filter time | 36 |
| Firmware runtime | 38 |

H

| | |
|--------------------------|----|
| Housing dimensions | 14 |
|--------------------------|----|

I

| | |
|--|----|
| Indicators, diagnostics and status | 19 |
| Inputs | |
| Device errors | 22 |
| Equivalent | 18 |
| I/O errors | 21 |
| Non-equivalent..... | 18 |
| Parameterization | 36 |
| Requirements for sensors | 15 |
| Single-channel | 18 |
| Single-channel assignment | 15 |
| Two-channel | 18 |
| Two-channel assignment | 15 |
| Installation..... | 29 |
| Electrical | 33 |
| Insulation rating..... | 10 |

M

| | |
|-------------------|----|
| Maintenance | 77 |
|-------------------|----|

O

| | |
|----------------------|----|
| Operating time | 21 |
| OSSD | |
| Single-channel | 48 |
| Two-channel | 58 |

P

| | |
|-----------------------|--------|
| Parameterization..... | 35, 39 |
| Inputs | 36 |

AXL F SSDI8/4 1F

| | |
|------------------------------------|--------|
| PELV | 10, 25 |
| Power supply units | 10 |
| Processing time of the input | 38 |

Q

| | |
|---------------------------|---|
| Qualified personnel | 9 |
|---------------------------|---|

R

| | |
|---------------------------|----|
| Removal | 29 |
| Repair | 77 |
| Replacement, module | 69 |
| Restart | 69 |

S

| | |
|---|--------|
| Safe state | 21 |
| Inputs | 21, 22 |
| Operating state | 21 |
| Safety integrity | 42 |
| Safety notes | 9 |
| SafetyBridge address | 35 |
| Sensors | |
| Connection options | 18 |
| Requirements | 15 |
| Standards | 11 |
| Start inhibit due to symmetry violation | 36 |
| Startup | 67 |
| Startup mode | 68 |
| Status indicators | 19 |
| Supply voltage | |
| UBUS | 25 |
| UI | 25 |
| Symmetry | 36 |

T

| | |
|--------------------|----|
| tFilter | 38 |
| tFW | 38 |
| tIN | 38 |
| Transmission speed | |
| Setting | 30 |

U

| | |
|---------------------|----|
| Use, intended | 11 |
|---------------------|----|

V

| | |
|------------------|----|
| Validation | 69 |
|------------------|----|

C Appendix: revision history

| Revision | Date | Contents |
|----------|------------|---|
| 00 | 2016-03-22 | First publication |
| 01 | 2016-11-10 | HW/FW revision updated Error code 035x and error location revised EMC Directive updated |
| | | page 2 page 75 page 83 |

AXL F SSDI8/4 1F



SCATTERGOOD & JOHNSON LTD

ELECTRICAL ENGINEERING & FLUID CONTROL DISTRIBUTORS

Est.1899

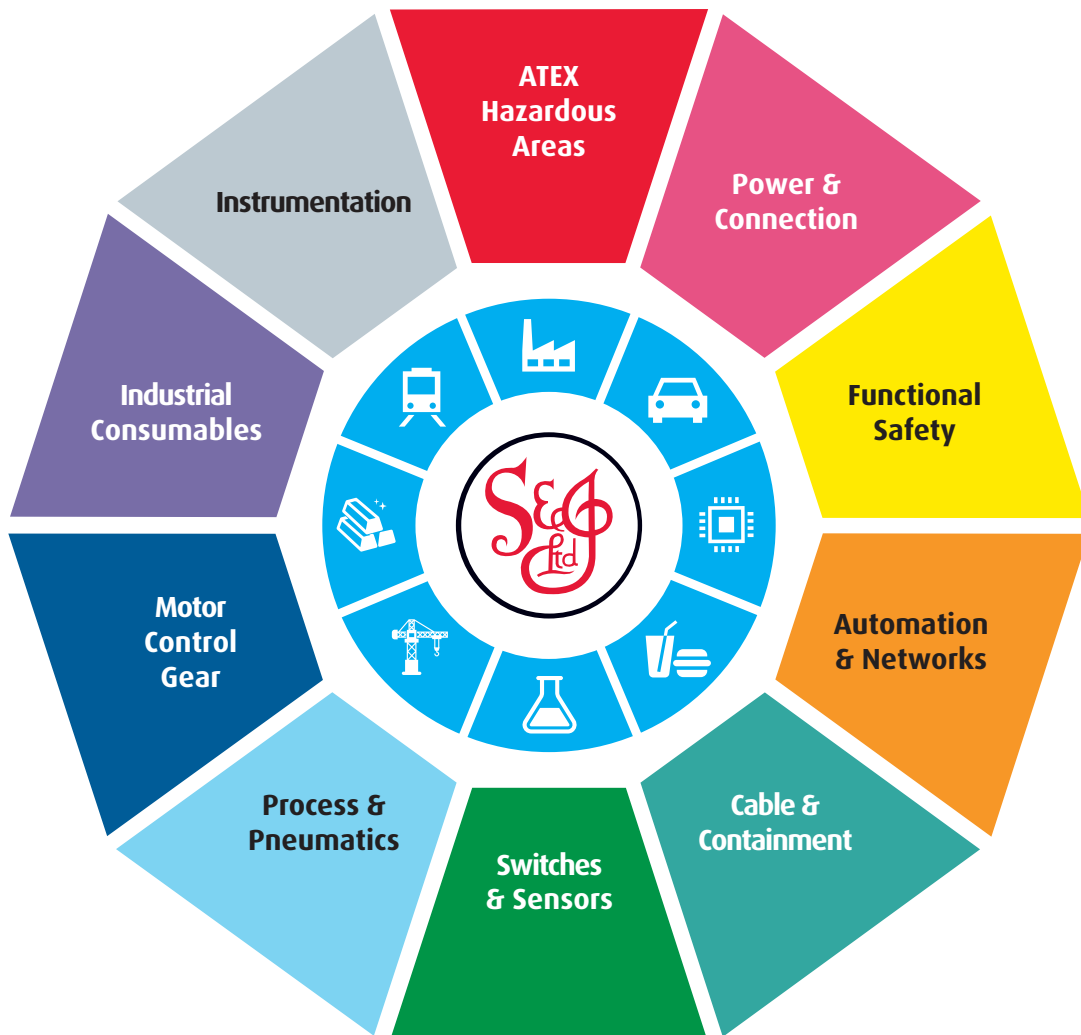
At Scattergood & Johnson Ltd, we pride ourselves on being a technical distributor to specialist industries.

Working with a range of quality product suppliers across a number of specialist markets, we are not your average 'box shifter' - we are your technical and supply chain partner.

We fully support every product we sell - for free! Our internal team and external sales engineers can answer any product or application question, no matter the complexity.

Backing up this technical ability is a range of 50,000+ products available from stock for nationwide next day delivery (same day if required!), or you can collect what you need from any of our trade counters around the UK.

Select your specialist interest below to learn more about how we can help.



Online, In Branch and On the Road - Scattergood & Johnson Ltd, there when you need us.

www.scatts.co.uk