



Axioline F safety module with safe digital outputs

User manual

User manual

Axioline F safety module with safe digital outputs

2016-11-10

Designation: UM EN AXL F SSDO8/3 1F

Revision: 01

This user manual is valid for:

Designation	From HW/FW revision	Order No.
AXL F SSDO8/3 1F	01/220	2702264

Please observe the following notes

User group of this manual

The use of products described in this manual is oriented exclusively to:

- Qualified electricians or persons instructed by them, who are familiar with applicable standards and other regulations regarding electrical engineering and, in particular, the relevant safety concepts.
- Qualified application programmers and software engineers, who are familiar with the safety concepts of automation technology and applicable standards.

Explanation of symbols used and signal words



This is the safety alert symbol. It is used to alert you to potential personal injury hazards. Obey all safety measures that follow this symbol to avoid possible injury or death.

There are three different categories of personal injury that are indicated with a signal word.

DANGER This indicates a hazardous situation which, if not avoided, will result in death or serious injury.

WARNING This indicates a hazardous situation which, if not avoided, could result in death or serious injury.

CAUTION This indicates a hazardous situation which, if not avoided, could result in minor or moderate injury.



This symbol together with the signal word **NOTE** and the accompanying text alert the reader to a situation which may cause damage or malfunction to the device, hardware/software, or surrounding property.



This symbol and the accompanying text provide the reader with additional information or refer to detailed sources of information.

How to contact us

Internet

Up-to-date information on Phoenix Contact products and our Terms and Conditions can be found on the Internet at:

phoenixcontact.com

Make sure you always use the latest documentation.

It can be downloaded at:

phoenixcontact.net/products

Subsidiaries

If there are any problems that cannot be solved using the documentation, please contact your Phoenix Contact subsidiary.

Subsidiary contact information is available at phoenixcontact.com.

Published by

PHOENIX CONTACT GmbH & Co. KG
 Flachsmarktstraße 8
 32825 Blomberg
 GERMANY

Should you have any suggestions or recommendations for improvement of the contents and layout of our manuals, please send your comments to:

tecdoc@phoenixcontact.com

Please observe the following notes

General terms and conditions of use for technical documentation

Phoenix Contact reserves the right to alter, correct, and/or improve the technical documentation and the products described in the technical documentation at its own discretion and without giving prior notice, insofar as this is reasonable for the user. The same applies to any technical changes that serve the purpose of technical progress.

The receipt of technical documentation (in particular user documentation) does not constitute any further duty on the part of Phoenix Contact to furnish information on modifications to products and/or technical documentation. You are responsible to verify the suitability and intended use of the products in your specific application, in particular with regard to observing the applicable standards and regulations. All information made available in the technical data is supplied without any accompanying guarantee, whether expressly mentioned, implied or tacitly assumed.

In general, the provisions of the current standard Terms and Conditions of Phoenix Contact apply exclusively, in particular as concerns any warranty liability.

This manual, including all illustrations contained herein, is copyright protected. Any changes to the contents or the publication of extracts of this document is prohibited.

Phoenix Contact reserves the right to register its own intellectual property rights for the product identifications of Phoenix Contact products that are used here. Registration of such intellectual property rights by third parties is prohibited.

Other product identifications may be afforded legal protection, even where they may not be indicated as such.

Table of contents

1	For your safety	9
	1.1 General safety notes.....	9
	1.2 Electrical safety	10
	1.3 Safety of the machine or system.....	11
	1.4 Directives and standards	11
	1.5 Intended use.....	11
	1.6 Documentation	12
	1.7 Abbreviations used	12
	1.8 Safety hotline.....	12
2	Product description.....	13
	2.1 Short description of the module	13
	2.2 Structure of the module	14
	2.3 Housing dimensions	14
	2.4 Safe digital outputs	15
	2.5 Connection options for actuators depending on the parameterization	16
	2.6 Local diagnostics and status indicators	17
	2.7 Safe state	19
	2.7.1 Operating state	19
	2.7.2 Error detection in I/O devices	19
	2.7.3 Device errors	20
	2.7.4 Parameterization errors	20
	2.8 Process data words	21
	2.9 Programming data/configuration data.....	23
3	Integration of the Axioline F local bus	25
	3.1 Supply voltage of the module logic	25
	3.2 Supply voltage U_O	26
	3.3 DC distribution network according to IEC 61326-3-1	27
	3.4 Terminal point assignment.....	27

AXL F SSD08/3 1F

4	Assembly, removal, and electrical installation.....	29
4.1	Assembly and removal	29
4.1.1	Unpacking the module	29
4.1.2	Preparation and assembly	29
4.1.3	Setting the DIP switch	30
4.1.4	Mounting and removing the module	31
4.2	Electrical installation	33
4.2.1	Electrical installation of the AxioLine F station	33
4.2.2	Electrical installation of the module	33
5	Parameterization of the module	35
5.1	Parameterization in a SafetyBridge system	35
5.2	Parameterization of the safe outputs	36
5.3	Behavior of the outputs in the event of enabled switch-off delay for stop category 1	37
6	Connection examples for safe outputs.....	39
6.1	Explanation of the examples.....	39
6.2	Notes on the protective circuit of external relays/contactors (freewheeling circuit)	41
6.3	Measures to achieve a specific safety integrity.....	41
6.4	Single-channel assignment of safe outputs	43
6.5	Two-channel assignment of safe outputs	45
7	Startup and validation	49
7.1	Initial startup	49
7.1.1	Startup mode	50
7.2	Restart after replacing a module.....	51
7.2.1	Replacing a module	51
7.2.2	Restart	51
7.3	Validation.....	51
8	Errors: messages and removal	53
8.1	Displaying and reading errors.....	53
8.2	Acknowledging an error.....	53
8.3	Module replacement following an error.....	53
8.4	Note about the error codes	54
8.5	Error codes.....	55

Table of contents

9	Maintenance, repair, decommissioning, and disposal	61
9.1	Maintenance.....	61
9.2	Repair.....	61
9.3	Decommissioning and disposal.....	61
10	Technical data and ordering data	63
10.1	SafetyBridge system data.....	63
10.2	AXL F SSDO8/3 1F	63
10.3	Conformance with EMC Directive.....	67
10.4	Ordering data: module.....	68
10.5	Download data: software	68
10.6	Download data: documentation.....	68
A	Appendix: checklists	69
A 1	Planning	70
A 2	Assembly and electrical installation	71
A 3	Startup and parameterization	72
A 4	Validation	73
B	Appendix: index.....	75
C	Appendix: revision history.....	77

AXL F SSD08/3 1F

1 For your safety

Purpose of this user manual

This user manual provides information about how the module works, its operating and connection elements, and its parameter settings.

Validity of the user manual

This user manual is valid for the AXL F SSDO8/3 1F module in the version indicated on the inner cover page, as well as for the same or later versions if replaced with devices of the same type.

1.1 General safety notes



WARNING: Risk of injury

Depending on the application, inappropriate use of the module may result in serious injury.

- Observe all the safety notes and warning instructions provided in this section and elsewhere in this user manual.

Qualified personnel

In terms of this user manual, qualified personnel are persons who, because of their education, experience and instruction, and their knowledge of relevant standards, regulations, accident prevention, and service conditions, have been authorized to carry out any required operations, and who are able to recognize and avoid any possible dangers.

Furthermore, knowledge of the following topics and products is required:

- Non-safety-related target system (e.g., PROFIBUS, PROFINET, EtherCAT®)
- SafetyBridge system
- Components used
- Axioline F product range
- Operation of the software tools
- Safety regulations in the field of application

In the context of the use of the system, the following operations must only be carried out by qualified personnel:

- Planning
- Configuration, parameterization, programming
- Installation, startup, servicing
- Maintenance, decommissioning

Documentation

Observe all information in this user manual and the accompanying documents: see Section 1.6 “Documentation” on page 12.

Safety of personnel and equipment

The safety of personnel and equipment can only be assured if the module is used correctly: see Section 1.5 “Intended use” on page 11.

Error detection

Depending on the wiring and the parameterization, the module detects errors within the safety equipment.

AXL F SSD08/3 1F**Do not carry out any repairs or modifications**

It is prohibited for the user to carry out repair work or make modifications to the module. The housing must not be opened. The module is protected against tampering by means of security labels. The security label is damaged in the event of unauthorized repairs or opening of the housing. In this case, the correct operation of the safety module can no longer be ensured.

In the event of an error, send the module to Phoenix Contact or contact Phoenix Contact immediately and engage a service engineer.

Mismatching and polarity reversal of connections

Take care to avoid the mismatching, polarity reversal or tampering of connections. For increased protection against mismatching, connectors and slot markings are color coded.

1.2 Electrical safety

**WARNING: Loss of safety function/hazardous shock currents**

Incorrect installation can result in the loss of the safety function as well as hazardous shock currents.

- Observe the notes on electrical safety.
- Plan the modules used and their installation in the system according to the specific requirements.
- Recheck plants and systems retrofitted with SafetyBridge.

Direct/indirect contact

Protection against direct and indirect contact according to VDE 0100 Part 410 must be ensured for all components connected to the system. In the event of an error, parasitic voltages must not occur (single-fault tolerance).

Measures required:

- Using power supply units with safe isolation (PELV).
- Decoupling circuits, which are not PELV systems, using optocouplers, relays, and other components which meet the requirements of safe isolation.

Power supply units for 24 V supply

Only use power supply units with safe isolation and PELV according to EN 50178/VDE 0160 (PELV). These power supply units prevent short circuits between the primary and secondary side.

Make sure that the output voltage of the power supply does not exceed 32 V even in the event of an error.

Insulation rating

When selecting the equipment, please take into consideration the dirt and surge voltages which may occur during operation.

The module is designed for overvoltage category II (according to DIN EN 60664-1). If you expect surge voltages in the system, which exceed the values defined in overvoltage category II, implement additional measures for voltage limitation.

1.3 Safety of the machine or system

The machine/system manufacturer and the operator are responsible for the safety of the machine or system and the application in which the machine or system is used.

Draw up and implement a safety concept

In order to use the module, a safety concept is required for your machine or system. This includes a hazard and risk analysis as well as a test report (checklist) for validating the safety function: see Section 1.4 “Directives and standards” on page 11, see Section A “Appendix: checklists” on page 69.

The target safety integrity (SIL according to IEC 61508, SILCL according to EN 62061 or performance level and category according to EN ISO 13849-1) is ascertained on the basis of the risk analysis. The safety integrity ascertained determines how to connect and parameterize the module within the safety function.

Validate hardware and parameterization

Carry out a validation every time you make a safety-related modification to your overall system.

Use your test report to ensure that:

- The safe modules are connected to the correct sensors and actuators
- The safe input and output channels have been parameterized correctly
- The variables have been linked to the safe sensors and actuators (single-channel or two-channel) correctly

1.4 Directives and standards

The standards to which the module conforms are listed in the certificate issued by the approval body and in the EC declaration of conformity (see: phoenixcontact.net/products).

1.5 Intended use

The AXL F SSSDO8/3 1F module is designed exclusively for use in a SafetyBridge system. It can only perform its tasks in the system if it is used according to the specifications in this document.

Only use the module according to the defined technical data and ambient conditions: see Section 10 “Technical data and ordering data” on page 63.

The module is designed for connecting single-channel or two-channel actuators, which can be used in association with safety technology.

Examples of use for the module:

- Safety circuits according to EN 60204 Part 1
- Safe shutdown of contactors, motors (24 V DC), valves, ohmic, inductive, and capacitive loads

The module is **not** suitable for applications in which stop category 1 also has to be observed in the event of an error.

1.6 Documentation

Currentness and availability of documentation

Always use the latest documentation. Changes or additions to documentation can be found on the Internet (see: phoenixcontact.net/products).

SafetyBridge user manuals

User manuals:

- For the controller used
- For the logic module of the SafetyBridge system
- For the SafetyBridge system I/O modules used
- For the SafetyBridge system function blocks

Please also observe the information on the bus system used.

Documentation for the Axioline F product range

Axioline F: system and installation user manual, UM EN AXL F SYS INST

Documentation for the bus coupler used

1.7 Abbreviations used

Table 1-1 Abbreviations for safety requirements

Abbreviation	Meaning	Standard	Example
SIL	Safety integrity level	IEC 61508	SIL 2, SIL 3
SILCL	SIL claim limit	EN 62061	SILCL 3
Cat.	Category	EN ISO 13849-1	Cat. 2, Cat. 4
PL	Performance level	EN ISO 13849-1	PL e, PL d

Table 1-2 General abbreviations

Abbreviation	Meaning
PELV	Protective extra-low voltage according to EN 50178/VDE 0160
EUC	Equipment under control

1.8 Safety hotline

Should you have any technical questions, please contact our 24-hour hotline.

Phone: + 49 5281 9-46277, e-mail: safety-service@phoenixcontact.com

2 Product description

2.1 Short description of the module

The AXL F SSDO8/3 1F module is an output module for use at any point in an Axioline F station.

The module is designed for use in the SafetyBridge system. The SafetyBridge address is set via a DIP switch.

The module has four safe positive switching digital outputs for two-channel assignment or eight safe positive switching digital outputs for single-channel assignment.

The outputs can be parameterized according to the specific application and enable the integration of actuators in the safe SafetyBridge system.

In the SafetyBridge system, the module can be used to achieve safety functions with the following requirements depending on the operating conditions:

- Up to SIL 3 according to IEC 61508
- Up to SILCL 3 according to EN 62061
- Up to Cat. 4/PL e according to EN ISO 13849-1

2.2 Structure of the module

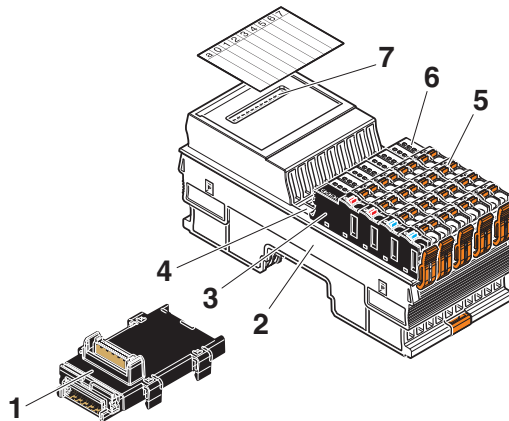

Figure 2-1 Structure of the module

- 1 Bus base module
- 2 Electronics module
- 3 Connector for connecting the supply voltage
- 4 Function identification
- 5 I/O connector
- 6 Diagnostics and status indicators
- 7 DIP switch



More detailed information on setting the switch: see Section 4.1.3 “Setting the DIP switch” on page 30.

2.3 Housing dimensions

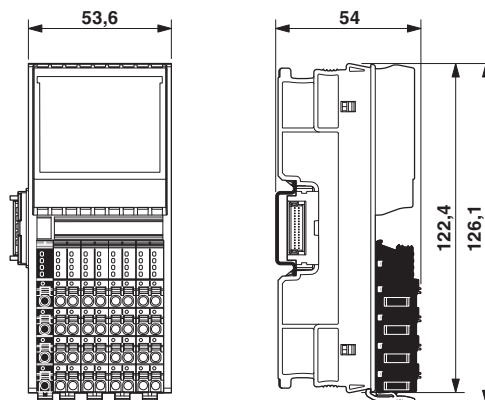

Figure 2-2 Housing dimensions (in mm)

2.4 Safe digital outputs

The module has safe digital outputs which can be used as follows:

- For two-channel assignment: four two-channel outputs
- For single-channel assignment: eight single-channel outputs

Technical data for the safe outputs: "Safe digital outputs" on page 65.

Parameterization

The safe digital outputs of a module can be parameterized in pairs. This means that the outputs can be adapted to various operating conditions and different safety integrity levels can be implemented (SIL, SILCL, Cat., PL).

In order to achieve a high level of error detection, the test pulses must be enabled. If this is not possible for the connected loads, the test pulses can be disabled, however, error detection is then reduced.



The safety integrity (SIL, SILCL, Cat., PL) and error detection that can be achieved depend on the parameterization, the structure of the actuator, and the cable installation: see Section 6 "Connection examples for safe outputs" on page 39.

Information on the parameterization of the outputs: see Section 5.2 "Parameterization of the safe outputs" on page 36.

Diagnostics

Diagnostics are provided via both the local diagnostics indicators and the diagnostic messages which are transmitted to the logic module.

Information on the diagnostic messages of the outputs: see Section 8 "Errors: messages and removal" on page 53.



WARNING: Loss of safety function

Using diagnostic data for safety-related functions can result in the loss of the safety function as diagnostic data is not safety-related.

- Do not use the diagnostic data for safety-related functions or actions.

Requirements for actuators/controlled devices

Functional safety places requirements on the design of actuators/controlled devices.

- Use suitable actuators/controlled devices which are described in the applicable safety standards, for example.

The module's ability to detect errors depends on the parameterization.

- Adapt the module parameterization to the relevant actuator/controlled device: see Section 5 "Parameterization of the module" on page 35.

If the outputs are parameterized with test pulses, the output circuits are tested by test pulses at regular intervals. These test pulses are visible at the output and can trigger undesirable reactions with quick responding actuators. The test pulses are either light pulses (brief activation) which can be disabled or dark pulses (brief deactivation) which cannot be disabled.

**WARNING: Unintentional machine startup**

Reactions from test pulses can cause unintentional machine startup.

- If the process does not tolerate this behavior, the following measures must be taken:
 - Use actuators with sufficient inertia.
 - Make sure that the load is not so dynamic that it causes hazardous states within 1 ms.

Quick actuators which offer a safety-related response to pulses in under 1 ms are not generally permitted.

Disabling the test pulses affects the error detection of the module.

- Observe the achievable safety integrity: see Section 6 “Connection examples for safe outputs” on page 39.
- Observe the notes on the safe assignment of outputs: see Section 6.4 “Single-channel assignment of safe outputs” on page 43, see Section 6.5 “Two-channel assignment of safe outputs” on page 45.

2.5 Connection options for actuators depending on the parameterization

Actuators that meet various safety requirements depending on the parameterization can be connected to the outputs.

The maximum achievable SIL/SILCL/Cat./PL is specified in the table.

In order to meet the safety requirements:

- Observe the information in the connection examples: see Section 6 “Connection examples for safe outputs” on page 39.
- Observe the requirements of the standards with regard to the external wiring and the actuators to be used to achieve a SIL/SILCL/Cat./PL: see Section 6.3 “Measures to achieve a specific safety integrity” on page 41.

“Output” parameterization	Output OUT0 to OUT3	
	Single-channel	Two-channel
Test pulses	Any	On/off*
Achievable safety integrity	SIL 2/SILCL 2/Cat. 3/PL d	SIL 3/SILCL 3/Cat. 4/PL e
For connection example, see page	43	45

* If the test pulses are disabled, a cross-circuit between the outputs is only detected if the output is enabled.



To achieve Cat. 3, two-channel actuators are usually used.

2.6 Local diagnostics and status indicators

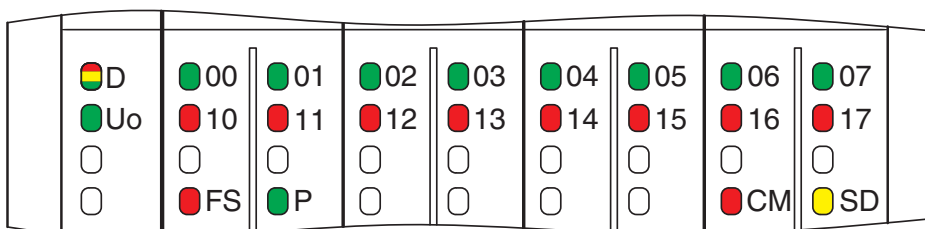



Figure 2-3 Local diagnostics and status indicators

Table 2-1 Overview of diagnostics LEDs

Des.	Color	State	Description
D	Red/yellow/ green	Diagnostics for local bus communication	
		Green on	The device is ready for operation, communication within the station is OK. All data is valid. There is no error.
		Flashing green	The device is ready for operation, communication within the station is OK. The data is not valid. Valid data from the controller/higher-level network not available. There is no error on the module.
		Flashing green/yellow	The device is ready for operation, communication within the station is OK. Output data cannot be output and/or input data cannot be read. There is an error on the I/O side of the module.
		Yellow on	The device is ready for operation, but has still not detected a valid cycle after power on.
		Flashing yellow	The device is not (yet) part of the active configuration.
		Red on	The device is ready for operation, but has lost the connection to the bus head.
		Flashing red	The device is ready for operation, but there is no connection to the previous device.
		Off	Device is in (power) reset.
UO	Green	Diagnostics for digital output supply	
		Green on	Supply for the digital outputs is present and is > around 17 V DC.
		Flashing green	Supply for the digital outputs is not present or is < around 17 V DC.
FS	Red	Diagnostics for failure state	
		Off	The safety application has a valid parameterization. (Only applies if UI is on or flashing at the same time.)
		Red on	Hardware fault. Communication to the higher-level controller is disabled. The module has entered the safe state (failure state).
		Flashing red	The module is not parameterized.

AXL F SSD08/3 1F

Des.	Color	State	Description
P	Green	Diagnostics for safe communication protocol	
		Off	No safe communication.
		Green on	Safe communication is running without errors.
		Flashing green	Safe communication is running. The SafetyBridge system is requesting an acknowledgment.
CM	Red	Startup mode	
		Off	SafetyBridge mode.
		Red on	Startup mode.  WARNING: In startup mode, the device is in standard operation. Startup mode: see Section 7.1.1 "Startup mode" on page 50.
SD	Yellow	Acknowledgment request	
		Off	No diagnostic message present that needs to be acknowledged.
		Yellow on	A diagnostic message is present that needs to be acknowledged for safe digital output errors, supply voltage errors or general errors. Acknowledgment: see Section 8.2 "Acknowledging an error" on page 53.
00 - 07	Green	Status of each output from 0 - 7	
		Off	Output at logic "0".
		Green on	Output at logic "1".
10 - 17	Red	Diagnostics for each output from 0 - 7	
		Off	No error present at the output.
		Red on	Error at the output (e.g., short circuit).

2.7 Safe state

The safe state for the module is the no load state at the output terminal blocks: see Section 2.4 “Safe digital outputs” on page 15.

The safe state can be entered in the following cases:

1. Operating state
2. Error detection in I/O devices
3. Device errors
4. Parameterization errors
5. Error detection during safe communication

2.7.1 Operating state

In the operating state, the outputs can enter states “1” or “0”. State “0” is the safe state.

2.7.2 Error detection in I/O devices

If an error is detected at an output, this output is disabled (“0” = safe state).

Outputs

Operating time in the error state



WARNING: Loss of the safe state in the failure state

In the failure state, internal module tests are no longer run and it is possible that the safe state may be exited due to an accumulation of errors.

- If the module enters an error state, assess, acknowledge or remove the error within 72 hours.

Depending on the parameterization, the following errors can be detected at outputs:

- Short circuit
- Cross-circuit
- Overload

The diagnostic message is transmitted to the logic module: see Section 8 “Errors: messages and removal” on page 53. Information on which errors are detected and when: see Section 6 “Connection examples for safe outputs” on page 39.



If an error occurs on a channel of an output parameterized as “two-channel”, the other corresponding channel also enters the safe state.

2.7.3 Device errors

Outputs

If a hardware fault in the internal circuit is detected at an output, **all** module outputs are disabled ("0" = off = safe state).

The diagnostic message is transmitted to the logic module: see Section 8 "Errors: messages and removal" on page 53.

Failure state: serious errors

Serious errors that can result in the loss of or adversely affect the safety function cause the entire module to enter the safe state. The FS LED on the module is permanently on. The failure state can only be exited by means of a power up.

The following serious errors result in the safe state:

- Serious hardware faults in the internal circuit
- User errors
- Module overload
- Module overheating

The diagnostic message is transmitted to the logic module: see Section 8 "Errors: messages and removal" on page 53.

**WARNING: Loss of safety function**

Sequential errors can result in the loss of the safety function.

- In the event of a device error, the module should be completely disconnected from the power supply and replaced so as to prevent sequential errors.

2.7.4 Parameterization errors

The module switches to the safe state following parameterization errors. The FS LED on the module flashes.

In the event of faulty parameterization, a diagnostic message is transmitted to the logic module: see Section 8 "Errors: messages and removal" on page 53.

2.8 Process data words



The module occupies four words in the Axioline F system.

Access the process data words via the “Operate” function block.

The module has feedback data and enable data.

Feedback data

The bits in this register mirror the states of the digital outputs as diagnostic data. This data can be used if an output has been parameterized with a switch-off delay. In this case, the feedback data can be used to determine the actual state of the output and derive information for the standard control process from this.

- Please note that the feedback data for certain errors (e.g., communication error) can differ from the actual state of the outputs.
- Do not use the diagnostic data to execute safety-related functions or actions.

The structure and function of the register are as follows:

Table 2-2 Feedback data register (mirrored data)

7	6	5	4	3	2	1	0
OUT3 _Ch2	OUT3 _Ch1	OUT2 _Ch2	OUT2 _Ch1	OUT1 _Ch2	OUT1 _Ch1	OUT0 _Ch2	OUT0 _Ch1

Enable

The enable principle is implemented in the SafetyBridge system. For this, all modules with local outputs have an enable function integrated in the device firmware (ANDed bit-by-bit) for each local safe output channel. The enable function can be parameterized (enabled/disabled) for each output pair.

The structure and function of the register are as follows:

Table 2-3 Enable data register

7	6	5	4	3	2	1	0
OUT3 _Ch2	OUT3 _Ch1	OUT2 _Ch2	OUT2 _Ch1	OUT1 _Ch2	OUT1 _Ch1	OUT0 _Ch2	OUT0 _Ch1

When the enable function is enabled, the relevant safe local output is ANDed bit-by-bit with the corresponding output bit of the standard controller. This output is then only set if the result of the safety function calculation permits this and the standard controller has set the corresponding output.

The enable function is performed according to the single-channel or two-channel parameterization of the safe outputs.



WARNING: Loss of safety function

The safety function must be triggered and canceled via the SafetyBridge system. If the safety function is triggered and canceled via standard components, there is no safety function.

- Check this when validating the overall safety function.



The enable function is not graphically represented in SAFECONF in the safety logic editor. Parameterize the enable function when parameterizing the channels.

AXL F SSSDO8/3 1F

The following figure illustrates the enable principle. For the corresponding parameterization of the output channels for this example, see Table 2-4.

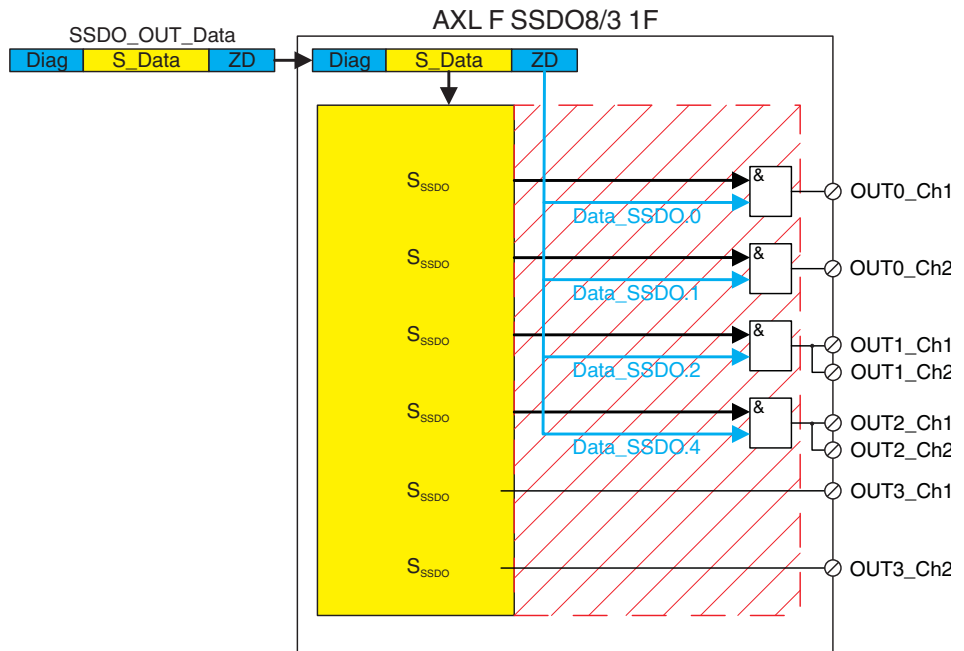

Figure 2-4 Enable principle (example)

Explanations for Figure 2-4:

- SSDO_OUT_Data** Output data from the logic module to the AXL F SSSDO8/3 1F
- S_Data** Safety data from the logic module
- Diag** Diagnostic data
- ZD** Enable data from the standard controller
- &** Standard function block for ANDing
- S_{SSDO}** Safe control signal from the logic module
- Data_SSSDO.x** Standard data of the standard controller, which is to enable the AXL F SSSDO8/3 1F; bit x
- OUTx_Ch1** See block description for the relevant controller.
- OUTx_Ch2** See block description for the relevant controller.
- OUTx_Ch1** Safe output x, channel y
- OUTx_Ch2** Safe output x, channel y
- Internal functionality that is enabled by means of parameterization; not visible in SAFECONF

Table 2-4 Parameterization of output channels for the example in Figure 2-4

Output/channel	Output	Enable	
		Parameterization	Bit
OUT0_Ch1	Single-channel	Enabled	0
OUT0_Ch2	Single-channel	Enabled	1
OUT1_Ch1	Two-channel	Enabled	2
OUT1_Ch2	Two-channel	Enabled	Not relevant
OUT2_Ch1	Two-channel	Enabled	4
OUT2_Ch2	Two-channel	Enabled	Not relevant
OUT3_Ch1	Single-channel	Disabled	Not relevant
OUT3_Ch2	Single-channel	Disabled	Not relevant



For two-channel parameterization, only use the process data bit of the first channel.

2.9 Programming data/configuration data

Phoenix Contact provides device description files for various control systems.



The programming data/configuration data is defined in the device description (FDCML, GSD, GSDML, etc.) according to the bus or network used.

AXL F SSD08/3 1F

3 Integration of the Axioline F local bus

The module is integrated for operation in an Axioline F station.



More detailed information on the structure of an Axioline F station: see UM EN AXL F SYS INST user manual.

3.1 Supply voltage of the module logic

The supply voltage for the module logic is generated in the bus coupler and led to the Axioline F module via the bus base module.



WARNING: Loss of safety function

The use of unsuitable power supplies can result in the loss of the safety function.

- Only use power supplies according to EN 50178/VDE 0160 (PELV) for the voltage supply at the bus coupler.
- Observe the general safety notes: see Section 1.2 “Electrical safety” on page 10.

Technical data for the supply voltage: see “Supply voltage U_{BUS} (logic)” on page 65.

The current carrying capacity for supply voltage U_{BUS} depends on the bus coupler used.

- Observe the technical data and information in the documentation for the bus coupler.

3.2 Supply voltage U_O

WARNING: Loss of safety function

The use of unsuitable power supplies can result in the loss of the safety function.

- Observe the general safety notes: see Section 1.2 “Electrical safety” on page 10.

WARNING: Loss of safety function

Parasitic voltages can result in the loss of the safety function.

- Supply supply voltage U_{BUS} and supply voltage U_O at the bus coupler from the same power supply unit so that the module loads are not affected by parasitic voltages in the event of an error.

Supply voltage U_O supplies the output circuits. Technical data for supply voltage U_O : see “Supply voltage U_O (actuators)” on page 65.

The maximum current carrying capacity for the main circuit U_O is 8 A.

NOTE: Module damage

Parallel protection against polarity reversal is only implemented in the device for a limited period. The following measures must be taken to prevent damage to the module:

- Due to the maximum current carrying capacity of 8 A, protect supply voltage U_O externally with an 8 AT fuse.
- Only use PELV power supply units with at least four times the nominal tripping current, as this is the only way to ensure tripping times of less than 300 ms.

Supply voltage U_O should feature a connection to functional earth ground according to EN 60204-1.

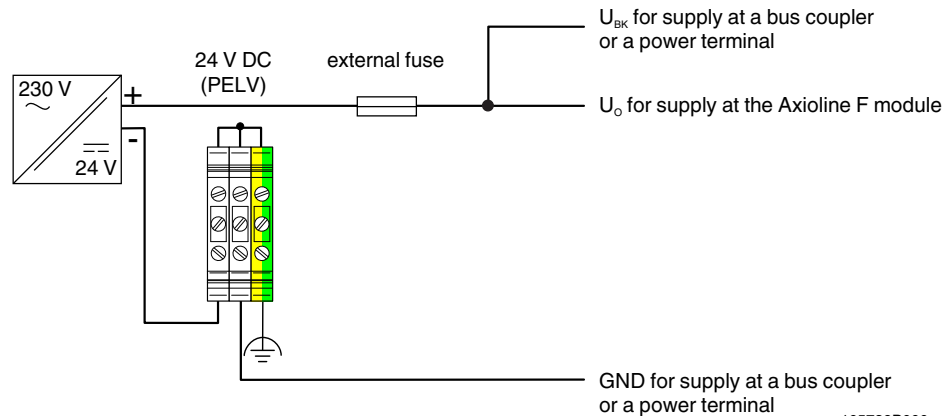

105739B000_en

Figure 3-1 Supply voltage U_O with connection to functional earth ground according to EN 60204-1

Observe the information regarding the behavior of the module in the event of an error at supply voltage U_O : see Section 8 “Errors: messages and removal” on page 53.

3.3 DC distribution network according to IEC 61326-3-1



NOTE: Damage to module electronics

A surge voltage will damage the module electronics.

- Do not use a DC distribution network.

A DC distribution network is a DC power supply network which supplies a complete industrial hall with DC voltage and to which any device is connected. A typical system or machine distribution is not a DC distribution network. For devices that are intended for a typical system or machine distribution, the DC connections are viewed and tested as I/O signals according to IEC 61326-3-1.

3.4 Terminal point assignment

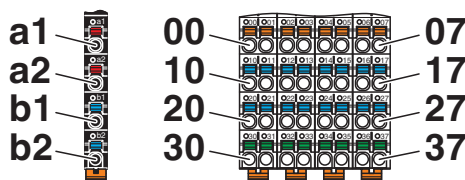

Figure 3-2 Terminal point assignment

The Axioline F connectors are supplied with the module. They are color coded and marked for connection.



Only use the connectors supplied with the module.

The following applies for the tables below:

- All outputs are safe digital outputs
- 0 V (GND): common ground of outputs
- FE: common functional earth ground

Table 3-1 Terminal point assignment of the voltage connection

Terminal point	Color	Assignment	
a1, a2	Red	24 V DC (UO)	UO: supply of the digital outputs (internally connected)
b1, b2	Blue	GND	Reference potential of the supply voltage (internally connected)

AXL F SSD08/3 1F

Table 3-2 Terminal point assignment of the I/O connection, connectors 1 and 2

	Color	Connector 1 (blue)		Connector 2 (red)	
Terminal point	Orange	00	01	02	03
Function		OUT0_CH1	OUT0_CH2	OUT1_CH1	OUT1_CH2
Terminal point	Blue	10	11	12	13
Function		GND	GND	GND	GND
Terminal point	Blue	20	21	22	23
Function		GND	GND	GND	GND
Terminal point	Green	30	31	32	33
Function		FE			

Table 3-3 Terminal point assignment of the I/O connection, connectors 2 and 3

	Color	Connector 3 (white)		Connector 4 (green)	
Terminal point	Orange	04	05	06	07
Function		OUT2_CH1	OUT2_CH2	OUT3_CH1	OUT3_CH2
Terminal point	Blue	14	15	16	17
Function		GND	GND	GND	GND
Terminal point	Blue	24	25	26	27
Function		GND	GND	GND	GND
Terminal point	Green	34	35	36	37
Function		FE			

**WARNING: Loss of safety function**

Parasitic voltages can result in the loss of the safety function.

- Connect the actuator ground to the ground terminal point of the corresponding output on the Axiline F connector. An external ground may not be used.

4 Assembly, removal, and electrical installation

4.1 Assembly and removal

4.1.1 Unpacking the module

**NOTE: Electrostatic discharge**

The module contains components that can be damaged or destroyed by electrostatic discharge.

- When handling the module, observe the safety precautions against electrostatic discharge (ESD) according to EN 61340-5-1 and IEC 61340-5-1.

- Read the package slip and follow the instructions.

The module may only be installed and removed by qualified personnel.

4.1.2 Preparation and assembly

**WARNING: Unintentional machine startup**

Make sure that the power to the system is disconnected before carrying out assembly and removal work as this could cause unintentional machine startup.

- Before assembling or removing the module, disconnect the power to the module and the entire Axioline F station and make sure that the system cannot be switched on again.
- Make sure the entire system is reassembled before switching the power back on and that neither the station nor the system poses a hazard.
Observe the diagnostics indicators and any diagnostic messages.

- Mount the module on a 35 mm DIN rail in a control cabinet or junction box protected from dust and humidity (IP54 or higher).
- Secure the control cabinet/junction box to prevent unauthorized opening.
- Only connect the cables using the supplied Axioline F connectors.

4.1.3 Setting the DIP switch

A DIP switch is located on the top of the module.

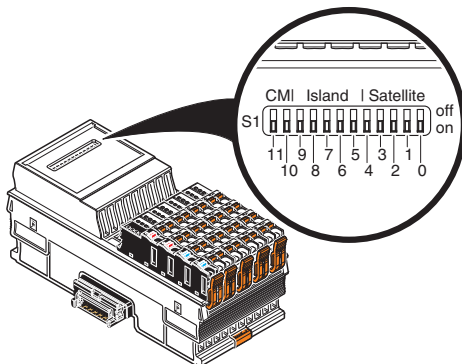

Figure 4-1 DIP switch

12-pos. DIP switch: address and operating mode

Set the SafetyBridge address and the operating mode via the 12-pos. DIP switch.

Overview of the switch positions

Table 4-1 Switch position

Operating mode	Reserved	SafetyBridge address									
		CM			Island number					Satellite number	
11	10	9	8	7	6	5	4	3	2	1	0
off/on	on	1 _{dec} to 31 _{dec}					1 _{dec} to 16 _{dec}				

- Switch 0 to 9:** SafetyBridge address (island number)
- Switch 10:** Reserved Always **on**
- Switch 11:** Operating mode **off** = SafetyBridge mode **on** = startup mode



Position 10 of the 12-pos. DIP switch is reserved and must always be in the “on” position. Otherwise, the module responds with a failure state.

Setting the address

- Remove the marking field and set the address in the switch below it.
- Reattach the marking field to the module.



The set address is only applied on power up. If the address is adjusted during operation, the module responds with a failure state.

4.1.4 Mounting and removing the module

Mounting the bus base module

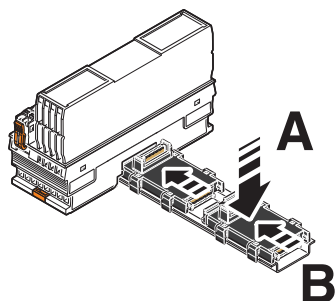

- Place all bus base modules required for the station on the DIN rail (A).
- Push the bus base modules into the connection for the bus coupler or the previous bus base module (B).

Snapping on and removing the electronics module

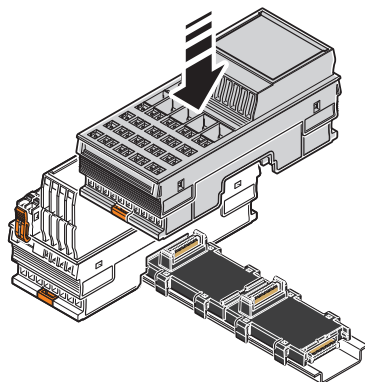

Snap on

- Place the electronics module vertically on the corresponding bus base module on the DIN rail until it snaps into place with a click. Make sure that the device connector for the bus base connection is situated above the corresponding socket on the bus base module.

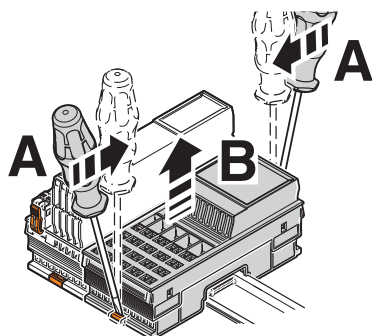

Remove

- Before removing the module, remove all connectors.
- Insert a suitable tool (e.g., bladed screwdriver) into the upper and lower snap-on mechanisms (base latches) of the module one after the other to release it (A).
- Remove the module perpendicular to the DIN rail (B).

AXL F SSD08/3 1F

Inserting and removing the connector

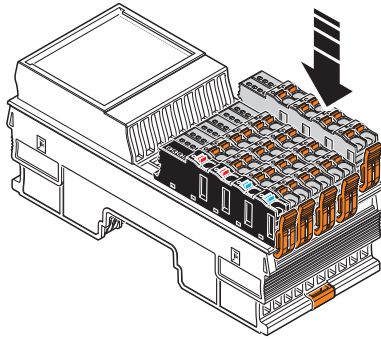

Insert

- Place the connector vertically into its position.
Note the color markings of the connectors/slots.
Assignment from left to right: blue, red, white, green.
- Press firmly on the connector. Make sure that the locking latch snaps in.

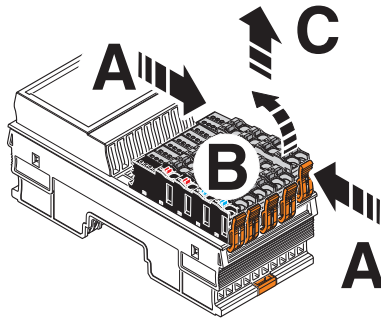

Remove

- Release the locking latch (A).
- Tilt the connector upwards slightly (B).
- Remove the connector from the module (C).

4.2 Electrical installation



WARNING: Electric shock/unintentional machine startup

Make sure that the power to the system is disconnected before carrying out installation work as this could cause a hazardous electric shock as well as unintentional machine startup.

- Prior to installation work, disconnect the power to the system and make sure that it cannot be switched on again unintentionally.
 - Make sure all work is completed before switching the power back on and that neither the station nor the system poses a hazard.
- Observe the diagnostics indicators and any diagnostic messages.

4.2.1 Electrical installation of the Axioline F station

Electrical installation of the Axioline F station includes the following:

- Connection to the higher-level bus system
- Connecting the supply voltages for the Axioline F station
- Carry out electrical installation for the Axioline F station according to the following user manuals:
 - Axioline F: system and installation user manual, UM EN AXL F SYS INST
 - Axioline F system manual for your bus system
- Observe the additional information in the documentation for the bus coupler.

4.2.2 Electrical installation of the module



Observe the general safety notes: see Section 1.2 "Electrical safety" on page 10.



WARNING: Loss of safety function/damage to equipment

Improper installation, e.g., due to the mismatching or polarity reversal of connections, can result in the loss of the safety function as well as damage to equipment.

- Take measures to prevent the mismatching or polarity reversal of connections.
- Prevent the tampering of connections.

The supply voltage for the module electronics is fed to the bus coupler. From this, the supply voltage of the module logic is provided via the bus base module. The supply voltage of the output circuits is fed directly to the module.

The actuators are connected via Axioline F connectors.

- Wire the connectors according to your application: see Section 3.4 "Terminal point assignment" on page 27.

AXL F SSD08/3 1F

5 Parameterization of the module

5.1 Parameterization in a SafetyBridge system

Parameterization includes the following:

- Assigning the SafetyBridge address
- Parameterizing outputs



The communication address configured in the controller project must match the address set on the device.

The settings on the device take effect after a power up.

SafetyBridge address

The SafetyBridge address is a unique ID for the safety module in the SafetyBridge structure. It is assigned in the configuration software for the assigned logic module.

The address of the connected satellites (here: AXL F SSSD08/3 1F) is based on the island number of the logic module and the position in the hardware editor of the SAFECONF configuration software.

- Set this address of the safety module via the DIP switches (see see “Setting the DIP switch” on page 30).



For more detailed information on the SafetyBridge address, please refer to the documentation for the logic module used.

Parameterization of outputs

The parameterization of the safe outputs determines the behavior of the module and influences the safety integrity that can be achieved.

The controller automatically writes the parameterization created in the configuration software to the module on every power up, reset or deactivation/activation of the “Operate” function block.

The following conditions must be met:

- Supply voltage is present
- Local bus is in the RUN state
- Communication connection has been established between the controller and the module

The module cannot be operated if it is not parameterized. The FS LED flashes.

The module is ready to operate if the parameters for all outputs are valid and transmitted without errors. Valid output data is only written in this state. In any other state, every output is set to the safe state.

If errors are detected during parameterization, the parameterization data is not applied. The FS LED flashes to indicate that the parameterization is invalid.

In addition, the error is indicated at the controller.

- In this case, check and correct the settings.

Information on error messages and troubleshooting: see Section 8 “Errors: messages and removal” on page 53.

5.2 Parameterization of the safe outputs

The individual output pairs of a module can be parameterized differently, which means that different safety integrity levels (SIL, SILCL, Cat., PL) can be achieved.

Two-channel

The following fixed assignment applies for two-channel operation:

- OUT0_Ch1 to OUT0_Ch2
- OUT1_Ch1 to OUT1_Ch2
- OUT2_Ch1 to OUT2_Ch2
- OUT3_Ch1 to OUT3_Ch2

Single-channel

For single-channel assignment, the outputs can be parameterized so that they operate independently of one another.

Parameterization

The safe outputs are parameterized in pairs for each connector. Table 5-1 describes the parameterization options.

Table 5-1 Parameterization of each output pair

Parameterization	Value range	Comment
Assignment	<ul style="list-style-type: none"> - Not used - Used <ul style="list-style-type: none"> - Single-channel - Two-channel 	The unused outputs are disabled. However, the monitoring of these outputs remains active. In two-channel operation, the assignment of the outputs is fixed.
Test pulses (output disabled) (in software: test impulses (output switched off))	<ul style="list-style-type: none"> - Disabled - Enabled 	Enabling and disabling of test pulses. For these test pulses, the output drivers that are disabled are temporarily enabled for test purposes (light pulses). Observe the notes below this table.
Switch-off delay for stop category 1	<ul style="list-style-type: none"> - Disabled - Enabled 	Disabled (default): no switch-off delay. Enabled: the outputs switch off once the set switch-off delay has elapsed (250 ms/500 ms/1 s/2 s/4 s/8 s/16 s/32 s/64 s/128 s). Accuracy: ±5% of the set value
Assignment of the switch-off delay	<ul style="list-style-type: none"> - Two-channel - To channel 2 	Either two-channel assignment or assignment to just channel 2 is possible for the switch-off delay.
Enable	<ul style="list-style-type: none"> - Disabled - Enabled 	Disabled (default value): the corresponding safe output is operated exclusively according to the safety logic. Enabled: enable is active; the safe output data is output after being ANDed with the "Data_LPSDO" process data item. See also see "Enable" on page 21.
The default values are shown in bold .		

Test pulses

If the light pulses are disabled, cross-circuits and short circuits cannot be detected when the output is switched off. However, outputs parameterized as "Not used" are tested with test pulses.

Observe the additional information: see "Requirements for actuators/controlled devices" on page 15, see Section 6 "Connection examples for safe outputs" on page 39.

5.3 Behavior of the outputs in the event of enabled switch-off delay for stop category 1

The affected outputs are only set to the safe state once the switch-off delay has elapsed. The switch-off delay can be interrupted by switching the output on again.

The time until the outputs are actually switched off depends on the parameterization of the switch-off delay and the event that causes the outputs to be switched off.

In the event of an error (excluding bus errors) the affected outputs are switched off immediately (without delay). In this case, only stop category 0 is supported.

Table 5-2 Switching off the outputs according to the trigger event and the parameterization

Switching off outputs	Influence of set switch-off delay	Switching off outputs
By the controller	Yes	Once the set switch-off delay has elapsed
After a bus error	Yes	Once the set switch-off delay has elapsed
After a short circuit, cross-circuit, failure of the supply voltage or hardware fault	No	Immediately (only stop category 0)



WARNING: Incorrect/insufficient safety distances

Selecting the wrong switch-off delay can result in incorrect safety distances being designed.

- When designing the safety distances, take the selected switch-off delay into consideration.

AXL F SSD08/3 1F

6 Connection examples for safe outputs

6.1 Explanation of the examples



WARNING: Loss of safety function

Improperly executed applications can result in the loss of the safety function.

- Observe the information to achieve the specified safety integrity: see Section 6.3 “Measures to achieve a specific safety integrity” on page 41.
- Make sure that the actuator has appropriate diagnostic coverage and an appropriate MTTFd to achieve the specified PL.
For applications according to PL d, high diagnostic coverage (> 99%) is recommended, however medium diagnostic coverage (90% to 99%) and a medium MTTFd are required at the very least.
For applications according to PL e, high diagnostic coverage (> 99%) and a high MTTFd are required.
- Use actuators that can achieve the required safety integrity.
- Evaluate the readback contacts to achieve Cat. 3 or Cat. 4.



WARNING: Loss of safety function

Improperly executed applications can result in the loss of the safety function.

- Prevent the supply of an external voltage in an output (e.g., due to cross-circuits).
- Install the connecting cables for the actuators so that they are protected against cross-circuits.
- Observe the load-carrying capacity of the outputs: see Section 2.4 “Safe digital outputs” on page 15.



NOTE: Damage to equipment

Incorrect supply of an external voltage can damage the module.

- Prevent the supply of an external voltage in an output (e.g., due to cross-circuits).



- For the examples, please also observe the measures specified in the tables as well as standards IEC 61508, EN 62061, and EN ISO 13849-1 to achieve the specified SIL/SILCL/Cat./PL.



The above notes apply in general for all of the connection examples in this section.

- Also observe the notes listed in the individual connection examples.

If the settings do not contradict one another, the outputs of a module can achieve different safety integrity levels (SIL, SILCL, Cat., PL) simultaneously.

The examples only describe the options for the electrical connection of controlled devices/actuators to the safe outputs.

Should you have any questions regarding your applications, please contact the Phoenix Contact safety hotline: see Section 1.8 “Safety hotline” on page 12.

The following are specified for each example:

AXL F SSD08/3 1F

- **Basic specifications**
The table specifies the main data for the example.
- **Device diagnostics and behavior of the module in the event of an error**
Diagnostic capability depends on the parameterization.
If a message is generated for an error, the message is specified in the tables.
Information on the relevant error code as well as possible solutions and information as to whether the error message must be acknowledged: see Section 8 “Errors: messages and removal” on page 53.
- **Typical parameterization**
The table illustrates an example of all the parameters for the specified assignment.

Key for tables in this section:

Representation	Meaning
Bold	Mandatory setting
Normal	Typical setting, another setting is possible depending on the application
–	Not evaluated

Errors (cross-circuits, short circuits) which can be prevented by correct installation (e.g., protected cable installation, isolated cable installation, double insulation, use of ferrules) are not described in the tables.

Only errors between outputs, which are on the same connector, are described. For example, in the event of correct installation, cross-circuits with outputs of other connectors cannot occur.

6.2 Notes on the protective circuit of external relays/contactors (freewheeling circuit)

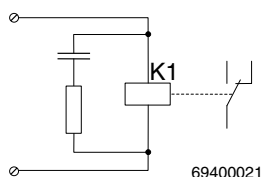

Figure 6-1 Example of the freewheeling circuit for an external relay

Observe the following measures:

- Limit the voltage induced on circuit interruption to $< -15\text{ V}$ (e.g., with RC elements, suppressor diodes or varistors).
- Please note that the freewheeling circuit affects the fall time and the service life of the contactor.
- Please observe the specifications of the relay manufacturer when dimensioning the relay protective circuit.

6.3 Measures to achieve a specific safety integrity

The safety integrity (SIL, SILCL, category, and performance level) that can be achieved is specified for each connection example.

SIL, SILCL



Use the standard to determine the probability of failure in your application according to IEC 61508 (SIL) and EN 62061 (SILCL).

Table 6-1 PFD and PFH depending on the SIL/SILCL

Safety integrity	PFD	PFH
SIL 2/SILCL 2	1% of 10^{-2}	1% of 10^{-6}
SIL 3/SILCL 3	1% of 10^{-3}	1% of 10^{-7}

Performance level



Use standard EN ISO 13849-1 to determine the performance level.

AXL F SSSD08/3 1F**Category**

The categories are achieved with the following measures:

Measure	Cat. 2	Cat. 3	Cat. 4
Use proven and basic safety principles according to EN ISO 13849-2.	x	x	x
Use qualified actuators: see "Requirements for actuators/controlled devices" on page 15.	x	x	x
Please note that mechanical failure of the switching device can result in the loss of the safety function.	x	x	x
Prevent the welding of contacts on the connected contactors or safety relays with protection against overcurrent and surge voltage.	x	x	x
Please note that a single error can result in the loss of the safety function between tests.	x		
Make sure that the external wiring is tested by the machine controller on machine startup and at suitable intervals. This test must detect the loss of the safety function.	x		
Make sure that in the event of an error the module shuts down safely or generates a warning (optical and/or audible) depending on the application.	x		
Please note that all errors that cannot be detected can result in the loss of the safety function. Take measures to prevent these errors (e.g., protected cable installation or double insulation). Observe the notes in the following tables.		x	x
Please take into consideration errors with a common cause.		x	x
Make sure that a single error does not result in the loss of the safety function.		x	
Test the shutdown capability of the actuators at regular intervals for test pulses that are disabled.		x	x
An accumulation of errors must not result in the loss of the safety function. Following the third error, evaluation can be aborted if the probability of further errors occurring is low.			x

6.4 Single-channel assignment of safe outputs

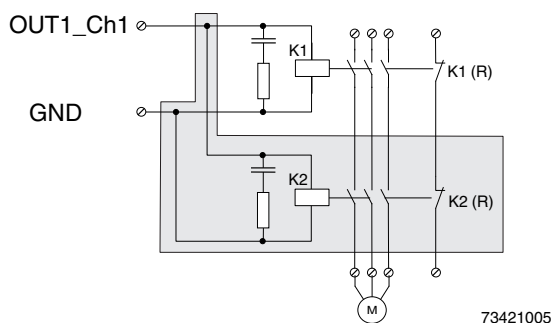

Figure 6-2 Single-channel assignment of outputs

In order to achieve Cat. 3 or PL d with single-channel assignment of the outputs:

- Use a two-channel actuator.

The two-channel operation of the actuator with the corresponding connection is represented on a gray background.

The failure detection time is 20 ms. High pulses of this width can occur in the event of an error.

If the application responds to these pulses:

- Use the two-channel assignment of the outputs.

K1 (R) and K2 (R) represent the force-guided N/C contacts for monitoring the state of the relay (readback contacts). Connect these contacts via safe digital inputs. Evaluate the readback and therefore the state of the switching elements in the safe application program.



WARNING: Loss of safety function

Parasitic voltages can result in the loss of the safety function.

- Connect the actuator ground to the ground terminal point of the corresponding output on the Axioline F connector. An external ground may not be used.

Basic specifications

Actuator	Single-channel	Two-channel
Achievable safety integrity	SIL 2/SILCL 2/Cat. 2/PL c	SIL 2/SILCL 2/Cat. 3/PL d



WARNING: Loss of safety function

The specified safety category can only be achieved under the following condition:

- Enable the test pulses in order to achieve Cat. 3 and PL d.



Enable the test pulses to improve device diagnostics and for long off times.

AXL F SSD08/3 1F

Device diagnostics and behavior of the module in the event of an error

Table 6-2 Single-channel: test pulses enabled

Error type	Detection	Diagnostics	Loss of SF ¹	Comment
Error in the actuator				
Despite being disabled, the actuator does not switch to the safe state (e.g., a contact will not open)	No	None	Yes	Detect errors using external monitoring. Please note all errors that can occur in the actuator. Test the shutdown capability of the actuator at regular intervals. If necessary, use a two-channel actuator.
Actuator cannot be enabled (e.g., interrupt)	No	None	No	Detect errors using external monitoring. Please note all errors that can occur in the actuator. Ensure that this error does not result in delayed system startup.
Other errors (depending on the actuator)				Please note all errors that can occur in the actuator.
Error in the wiring				
Interrupt				
Cable interrupt between output and actuator or between actuator and ground	No	None	No	Detect errors using external monitoring. Please note all errors that can occur in the actuator. Ensure that this error does not result in delayed system startup.
Cross-circuit				
Output to output	Yes	All OUT LEDs: red on	Yes	When the outputs are disabled, a cross-circuit between the outputs is only detected if the test pulses are enabled. If an error is detected, the module disables all its outputs.
Short circuit				
Output to ground or output to FE	Yes	Short circuit or overload, OUTx ²	No	The error is detected in the ON state. The output is disabled (safe state).  WARNING: Unexpected machine startup Acknowledging an error activates the outputs again. This can result in unexpected machine startup. <ul style="list-style-type: none"> Before acknowledging an error, make sure that no persons can access the danger zone.

¹ SF = safety function

² OUTx = diagnostic message (LED) for each output X

Typical parameterization

Parameterization	Parameterized as	Comment
Assignment	Used	
Test pulses (output disabled) (in software: test impulses (output switched off))	Enabled	Or disabled
Switch-off delay for stop category 1	Enabled	Or disabled
Output	Single-channel	
Enable	Enabled	Or disabled

6.5 Two-channel assignment of safe outputs

For two-channel assignment of the safe outputs, two adjacent outputs of the same connector are used. This assignment cannot be parameterized: see "Two-channel" on page 36.

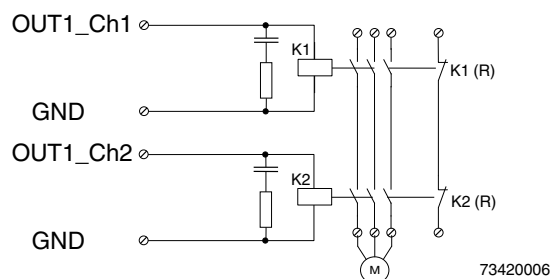

Figure 6-3 Two-channel assignment of outputs

K1 (R) and K2 (R) represent the force-guided N/C contacts for monitoring the state of the relay (readback contacts).

- Connect these contacts via safe digital inputs.
- Evaluate the readback and therefore the state of the switching elements in the safe application program.



WARNING: Loss of safety function

Parasitic voltages can result in the loss of the safety function.

- Connect the actuator ground to the ground terminal point of the corresponding output on the Axioline F connector. An external ground may not be used.

The failure detection time does not have to be taken into consideration for two-channel assignment.

Basic specifications

Actuator	Two-channel
Achievable safety integrity	SIL 3/SILCL 3/Cat. 4/PL e



Enable the test pulses to improve device diagnostics and for long off times.

AXL F SSD08/3 1F

Device diagnostics and behavior of the module in the event of an error

Table 6-3 Two-channel

Error type	Detection	Diagnostics	Loss of SF ¹	Comment
Error in the actuator				
Despite being disabled, a switching element of the two-channel actuator does not switch to the safe state (e.g., a contact will not open)	No	None	No	No loss of the safety function as the second switching element of the two-channel actuator can be disabled. Detect errors using external monitoring. Implement a restart inhibit in the event of this error. Please note all errors that can occur in the actuator. Test the shutdown capability of the actuator at regular intervals.
Actuator cannot be enabled (e.g., interrupt)	No	None	No	Detect errors using external monitoring. Please note all errors that can occur in the actuator. Ensure that this error does not result in delayed system startup.
Other errors (depending on the actuator)				Please note all errors that can occur in the actuator.
Error in the wiring				
Interrupt				
Cable interrupt between output and actuator or between actuator and ground	No	None	No	Detect errors using external monitoring. Please note all errors that can occur in the actuator. Ensure that this error does not result in delayed system startup.
Cross-circuit				
Output to output	Yes (conditional)	All OUT LEDs: red on	No	When the outputs are disabled, a cross-circuit between the outputs is only detected if the test pulses are enabled. If an error is detected, the module disables all its outputs. If the test pulses have been disabled, test the circuit and the external wiring at regular intervals by enabling the outputs.
Short circuit				
Output to ground or output to FE	Yes	Short circuit or overload, OUTx ²	No	The error is detected in the ON state. The output is disabled (safe state).  WARNING: Unexpected machine startup Acknowledging an error activates the outputs again. This can result in unexpected machine startup. <ul style="list-style-type: none"> Before acknowledging an error, make sure that no persons can access the danger zone.

¹ SF = safety function

² OUTx = diagnostic message (LED) for each output X

Connection examples for safe outputs
Typical parameterization

Parameterization	Parameterized as		Comment
	Channel 1	Channel 2	
Assignment	Used	Used	
Test pulses (output disabled) (in software: test impulses (output switched off))	Enabled	Enabled	
Switch-off delay for stop category 1	Enabled	Enabled	Or disabled
Output	Two-channel	Two-channel	
Enable	Enabled	Enabled	Or disabled

AXL F SSD08/3 1F

7 Startup and validation

7.1 Initial startup

Table 7-1 Steps for startup

Step	Relevant section and literature
Set the address.	"Setting the DIP switch" on page 30
Install the module in the Axioline F station.	"Assembly, removal, and electrical installation" on page 29 UM EN AXL F SYS INST user manual
Connect the bus system and supply voltage cables to the Axioline F station.	UM EN AXL F SYS INST user manual or documentation for the bus coupler
Wire the outputs according to your application.	"Connection examples for safe outputs" on page 39
Before applying the operating voltage: <ul style="list-style-type: none"> – Make sure that there are no wiring errors (e.g., cross-circuit or short circuit) or grounding errors by testing with a multimeter. – Make sure that functional earth ground is connected. 	
Connect the necessary voltages to the Axioline F station.	UM EN AXL SYS INST user manual or documentation for the module
Connect the necessary voltages (U_O) to the module.	"Supply voltage U_O (actuators)" on page 65
Once the operating voltage has been applied: <ul style="list-style-type: none"> – If possible, measure the waveform of the voltages to make sure that there are no deviations. – Measure the input voltages on the module to make sure that they are in the permissible range. – Use the LEDs on the module to check that the module starts up without any errors. 	
Check the assembly and installation.	Checklist: see Appendix A 2 "Assembly and electrical installation"
Carry out the necessary parameterization.	"Parameterization of the module" on page 35 Documentation for the logic module used (SafetyBridge)
Program the safety function.	Online help for the SAFECONF configuration software
Perform a function test and validation. Check whether the safety function responds as planned during programming and parameterization.	Checklist: see Appendix A 4 "Validation"
When connecting the supply voltages, use the diagnostics and status indicators to check whether the module has started up correctly or whether any errors are indicated.	Instructions on how to proceed in the event of an error: see Section 8 "Errors: messages and removal" on page 53

7.1.1 Startup mode



WARNING: Risk due to standard operation

The module is **not** safe in startup mode, as all partial safety functions are deactivated. Unintentional system states or incorrect responses cannot be ruled out.

- Do not enter any danger zones and make sure that no other persons can access the danger zone either.



WARNING: Risk due to unexpected machine startup

Unexpected machine startup can occur as a result of standard operation in startup mode.

- Take the standard behavior of the device in startup mode into consideration as early as the planning phase.
- Take appropriate safety precautions.

The device features a startup mode in which the Startup+ software can be used to perform the following functions:

- Wiring check
- Set outputs
- Read and acknowledge diagnostic messages

Startup mode is set using the DIP switch on the top of the module, see Section 4.1.3 “Setting the DIP switch” on page 30.

To enter startup mode, proceed as follows:

1. Set position 11 of the DIP switch to “on”.
2. Carry out a power up.

The red CM LED indicates that the device is in startup mode.

In the Startup+ software, enter the address set on the device.



For additional information on the Startup+ software, refer to the documentation for the software.

The software can be downloaded free of charge at phoenixcontact.net/products.

7.2 Restart after replacing a module

7.2.1 Replacing a module



WARNING: Unintentional machine startup

Make sure that the power to the system is disconnected before carrying out assembly and removal work as this could cause unintentional machine startup.

- Before assembling or removing the module, disconnect the power to the module and the entire Axioline F station and make sure that the system cannot be switched on again.
- Make sure the entire system is reassembled before switching the power back on and that neither the station nor the system poses a hazard.
Observe the diagnostics indicators and any diagnostic messages.

If replacing a module, proceed as described for assembly and removal: see Section 4 “Assembly, removal, and electrical installation” on page 29 or Axioline F: system and installation user manual, UM EN AXL F SYS INST.

- Install the new module at the correct position in the station.
- Observe the color coding of the connector/slot when mounting the connectors.

The new module must meet the following requirements:

- Same device type
- Same or later version

7.2.2 Restart

Once the module has been replaced, proceed as described for initial startup: see Section 7.1 “Initial startup” on page 49.

The parameterization of the previous module remains the same and is transmitted to the new module when the system is started.

7.3 Validation

Carry out a safety validation every time you make a safety-related modification.

- When validating your EUC, check the assignment of the individual actuator connections.
- Make sure that the following requirements are met:
 - The correct safe actuators are connected to the module.
 - The parameterization of the module is correct.
 - The variables used in your application program have been linked to the safe actuators correctly.

Observe the information on validation provided in the checklist: “Validation” on page 73.

AXL F SSD08/3 1F

8 Errors: messages and removal

8.1 Displaying and reading errors

Diagnostics indicators and diagnostic messages

Depending on the error type, errors that are diagnosed are displayed via the local diagnostics indicators and/or transmitted to the logic module as diagnostic messages.

Depending on the controller, the SafetyBridge function blocks provide error codes. In order to determine what type of error has occurred, use the corresponding software to access the standard controller online and read the error.

Please also refer to the documentation for the logic module used.

8.2 Acknowledging an error

Acknowledgment

An AXL F SSD08/3 1F error is acknowledged completely via the “Operate” function block.



WARNING: Acknowledgment may result in a hazardous system state

With the exception of a few special cases, the acknowledgment of an error immediately returns the safe input or output to the operating state.

- Before acknowledging an error you must therefore make sure that the acknowledgment will not cause the machine to switch to a hazardous state.
- When planning the machine or system, make sure that acknowledgment is only possible if the danger zone is visible.



For instructions on error acknowledgment, please refer to the documentation for the logic module used.

8.3 Module replacement following an error

If the safety module is replaced in the event of an error, proceed as described in “Assembly, removal, and electrical installation” on page 29 and “Restart” on page 51.

8.4 Note about the error codes

Error cause and error location

The error code of a diagnostic message consists of the code for the error cause and the code for the error location.

Refer to the examples below for an explanation of the error codes.

Table 8-1 Examples explaining the error codes

Higher-level error code;
x = error location

Detailed error code with
error location

Error location: input
and channel

YYY = not relevant

Error code (hex)	Error location	LED	Error cause Error description	Effect	Solution Acknowledgment
003x 0030 ... 003B	OUT0_Ch1 ... OUT3_Ch2	SD on	Short circuit or overload
02Cx 02C0	OUT0_Ch1&2	FS flashing	Incorrect parameterization
4YYY	-		No error - SafetyBridge address is displayed

Additional information about the error, possible solutions, and acknowledgment behavior.

Examples from Table 8-1:

0030: short circuit or overload at OUT0_Ch1 (output 0 channel 1)

02C0: incorrect parameterization for OUT0_Ch1&2 (output 0 channel 1 and 2)

4021: no error; the SafetyBridge address is displayed

The error codes are listed in ascending order in Table 8-2 "Error codes".



If error codes are indicated by the system which do not appear in the table, please contact Phoenix Contact.

8.5 Error codes

Table 8-2 Error codes

Error code (hex)	Error location	LED	Error cause Error description	Effect	Solution Acknowledgment
001x 0010 0011 0012 0013 0018 0019 001A 001B	OUT0_Ch1 OUT1_Ch1 OUT2_Ch1 OUT3_Ch1 OUT0_Ch2 OUT1_Ch2 OUT2_Ch2 OUT3_Ch2	SD on All OUT: red on	Hardware fault – The indicated output cannot be disabled Message can also be triggered by a cross-circuit/short circuit	All module outputs are in the safe state	1. Check whether the message was triggered by a short circuit/cross-circuit If not: 2. Replace module Acknowledgment: Acknowledgment triggers the message and results in a restart following an error-free selftest. Δ The states at the outputs are transmitted immediately.
003x 0030 0031 0032 0033 0038 0039 003A 003B	OUT0_Ch1 OUT1_Ch1 OUT2_Ch1 OUT3_Ch1 OUT0_Ch2 OUT1_Ch2 OUT2_Ch2 OUT3_Ch2	SD on	Short circuit or overload – A short circuit or overload has been detected at the indicated output	Affected output is in the safe state	1. Check actuator 2. Check connector and cabling 3. Check freewheeling circuit at the contactor Acknowledgment: Acknowledgment triggers the message and results in a restart following an error-free selftest. Δ The states at the outputs are transmitted immediately.
005x 0050 0051 0052 0053 0058 0059 005A 005B	OUT0_Ch1 OUT1_Ch1 OUT2_Ch1 OUT3_Ch1 OUT0_Ch2 OUT1_Ch2 OUT2_Ch2 OUT3_Ch2	SD on All OUT: red on	Error at the output or short circuit during the test – Pulse test (brief activation) at the output failed – Short circuit in the external wiring	All module outputs are in the safe state	1. Check wiring for short circuit Acknowledgment: Acknowledgment triggers the message and results in a restart following an error-free selftest. Δ The states at the outputs are transmitted immediately. If the error occurs permanently: 2. Replace module

AXL F SSD08/3 1F

Table 8-2 Error codes

Error code (hex)	Error location	LED	Error cause Error description	Effect	Solution Acknowledgment
006x 0060 0061 0062 0063 0068 0069 006A 006B	OUT0_Ch1 OUT1_Ch1 OUT2_Ch1 OUT3_Ch1 OUT0_Ch2 OUT1_Ch2 OUT2_Ch2 OUT3_Ch2	SD on All OUT: red on	Error at the output or short circuit/cross-circuit during the test – Pulse test (brief deactivation) at the output failed	All module outputs are in the safe state	1. Check wiring for short circuit Acknowledgment: Acknowledgment triggers the message and results in a restart following an error-free selftest. ⚠ The states at the outputs are transmitted immediately. If the error occurs permanently: 2. Replace module
0090	-	SD on All OUT: red on	Hardware fault – One or more outputs cannot be disabled Message can also be triggered by a cross-circuit/short circuit with an external signal	All module outputs are in the safe state	1. Check whether the message was triggered by a short circuit/cross-circuit If not: 2. Replace module Acknowledgment: Acknowledgment triggers the message and results in a restart following an error-free selftest. ⚠ The states at the outputs are transmitted immediately.
0091	-	SD on All OUT: red on	Hardware fault	All module outputs are in the safe state	1. Acknowledge error If acknowledgment is not possible: 2. Replace module Acknowledgment: Acknowledgment triggers the message and results in a restart following an error-free selftest. ⚠ The states at the outputs are transmitted immediately.

Errors: messages and removal

Table 8-2 Error codes

Error code (hex)	Error location	LED	Error cause Error description	Effect	Solution Acknowledgment
00Ax 00A0 00A1 00A2 00A3 00A8 00A9 00AA 00AB	OUT0_Ch1 OUT1_Ch1 OUT2_Ch1 OUT3_Ch1 OUT0_Ch2 OUT1_Ch2 OUT2_Ch2 OUT3_Ch2	SD on All OUT: red on	Cross-circuit – With another output or with an external signal	All module outputs are in the safe state	1. Check actuator 2. Check connector and cabling Acknowledgment: Acknowledgment triggers the message and results in a restart following an error- free selftest. Δ The states at the outputs are transmitted immediately.
01F0	-	UO flashing SD on	Undervoltage U_O – U_O below the permissible voltage range – If $U_O < 17\text{ V}$, a diagnostic message is generated	All module outputs are in the safe state	1. Check supply voltage level and correct 2. Check supply line length and load Acknowledgment: Acknowledgment deletes the message and activates the outputs. Δ The states at the outputs are transmitted immediately.
01F2	-	SD on	Critical device temperature	Immediate shutdown. A further temperature increase causes the module to switch to the safe state.	Check and adapt the following if necessary: – Ambient conditions – Derating – Switching frequency Acknowledgment: Acknowledgment deletes the message.
02Cx 02C0 02C1 02C2 02C3	OUT0_Ch1&2 OUT1_Ch1&2 OUT2_Ch1&2 OUT3_Ch1&2	FS flashing	Incorrect parameterization – A reserved value has been selected for the “Assignment of the outputs” parameterization	Module is in the safe state	1. Correct “Assignment of the outputs” parameterization 2. Resend parameter data to the module (deactivate/activate “Operate” block) Acknowledgment: not possible

AXL F SSD08/3 1F

Table 8-2 Error codes

Error code (hex)	Error location	LED	Error cause Error description	Effect	Solution Acknowledgment
02D0	-	FS flashing	Incorrect parameterization – A reserved value has been selected for the “Implicit enable” parameterization	Module is in the safe state	1. Correct “Implicit enable” parameterization 2. Resend parameter data to the module (deactivate/activate “Operate” block) Acknowledgment: not possible
02Ex 02E0 02E1 02E2 02E3	OUT0_Ch1&2 OUT1_Ch1&2 OUT2_Ch1&2 OUT3_Ch1&2	FS flashing	Incorrect parameterization – A reserved value has been selected for the “Switch-off delay” parameterization	Module is in the safe state	1. Correct “Switch-off delay” parameterization 2. Resend parameter data to the module (deactivate/activate “Operate” block) Acknowledgment: not possible
02F2	-	FS flashing	Switch-off delay still active – At least one output with parameterized switch-off delay is still performing a switch-off operation	Following switch off, the module is in the safe state	1. Wait for the switch-off operation 2. Resend parameter data to the module (deactivate/activate “Operate” block) Acknowledgment: not possible
03F2	-	FS flashing	Incorrect checksum – The calculated and received parameter record checksums do not match	Module is in the safe state	1. Resend parameter data to the module (deactivate/activate “Operate” block) Acknowledgment: not possible
03F3	-	FS flashing	Incorrect parameter data record – Parameter data record does not match the device	Module is in the safe state	1. Compare HW configuration with SAFECNF project 2. Check assignment of process data at the “Operate” block 3. Resend parameter data to the module (deactivate/activate “Operate” block) Acknowledgment: not possible

Errors: messages and removal

Table 8-2 Error codes

Error code (hex)	Error location	LED	Error cause Error description	Effect	Solution Acknowledgment
0440	-	FS flashing	Incorrect SafetyBridge address – The parameterized SafetyBridge address does not match the address set on the safety module	Module is in the safe state	1. Deactivate the “Operate” block. 2. See message “4YYY” on page 59. Acknowledgment: not possible
0441 ... 0446	-	SD on	Internal error	Module is in the safe state	Please contact Phoenix Contact. Acknowledgment: not possible
0447	-	SD on	Incorrect configuration and parameter data record – The device detected an error in the configuration and parameter data record	Module is in the safe state	1. Resend parameter data to the module (deactivate/activate “Operate” block) If the error occurs permanently: 2. Generate new data record in SAFECNF Acknowledgment: not possible
109A	-	FS on	DIP switch moved during operation	Module is in the safe state	1. Check DIP switch position and bring in line with SAFECNF project 2. Perform power up Acknowledgment: Not possible. Restart is only possible following power up and error-free selftest.
1YYY	-	FS on	Internal error	Module is in the safe state	Please contact Phoenix Contact. Acknowledgment: not possible
4YYY	-	FS flashing	No error – “Operate” block has been deactivated – SafetyBridge address is displayed	Module is in the safe state	1. Check DIP switch position and bring in line with SAFECNF project See Table 4-1 on page 30 and documentation for the logic module. 2. Activate “Operate” block

AXL F SSSD08/3 1F

Table 8-2 Error codes

Error code (hex)	Error location	LED	Error cause Error description	Effect	Solution Acknowledgment
8000	-	P on	No error	-	-

9 Maintenance, repair, decommissioning, and disposal

9.1 Maintenance

The module does not require maintenance. Depending on the application and connected I/O devices, the function of the I/O devices and the safety chain must be tested regularly.

The duration of use of the module is 20 years, or 25 years with a low demand rate.

Repeat testing during this time is not required.

- Carry out maintenance on connected I/O devices (e.g., light grid) according to the manufacturer specifications.

9.2 Repair

It is prohibited for the user to carry out repair work or make modifications to the module. The housing must not be opened. The module is protected against tampering by means of security labels. The security label is damaged in the event of unauthorized repairs or opening of the housing. In this case, the correct operation of the safety module can no longer be ensured.

- In the event of an error, send the module to Phoenix Contact or contact Phoenix Contact immediately and engage a service engineer.

9.3 Decommissioning and disposal

Carry out decommissioning according to the requirements of the machine or system manufacturer.

When decommissioning the system or parts of the system, ensure the following for the modules used:

Fate of the module	Measure
The modules will continue to be used correctly.	Observe the storage and transport requirements according to the technical data: see Section 10.2 "AXL F SSD08/3 1F" on page 63.
Modules will no longer be used.	Dispose of modules in accordance with the environmental regulations. Make sure that the modules can never be reused.

AXL F SSD08/3 1F

10 Technical data and ordering data

10.1 SafetyBridge system data

For the system data for the SafetyBridge system, please refer to the documentation for the logic module.

SafetyBridge

Processing time of the module 1.5 ms

10.2 AXL F SSD08/3 1F

General data

Housing dimensions (width x height x depth) 53.6 mm x 126.1 mm x 54 mm

Weight (with connectors) 220 g, approximately

Operating mode

SafetyBridge Process data mode with 4 words

Ambient temperature

Operation -35°C to +60°C (any mounting position)

Storage/transport: -40°C to +85°C

Humidity

Operation 75% on average, 85% occasionally



Measures against increased humidity must be taken.

Storage/transport: 75% on average, 85% occasionally



For a short period, slight condensation may appear on the outside of the housing.

Air pressure

Operation 70 kPa to 108 kPa (up to 3000 m above sea level)

Storage/transport: 66 kPa to 108 kPa (up to 3500 m above sea level)

Degree of protection IP20; operation in at least IP54 installation space

Housing material Plastic PBT, self-extinguishing (V0)

Air clearances and creepage distances According to IEC 60439-1, derived from IEC 60664-1

Protection class III (PELV), IEC 61140, EN 61140, VDE 0140-1

Gases that may endanger functions according to DIN 40046-36, DIN 40046-37 Not resistant to gas that may endanger functions (sulfur dioxide (SO₂), hydrogen sulfide (H₂S))

Resistance of the housing material to fungal decay Resistant

Ambient compatibility Not resistant to organic chlorine compounds

AXL F SSSD08/3 1F**General data [...]**

Connection data for Axilone F connectors

Connection method

Spring-cage terminal blocks

Conductor cross section

Solid: 0.5 mm² to 1.5 mm²
 Flexible without sleeve: 0.25 mm² to 1.5 mm²
 Flexible with sleeve: 0.25 mm² to 1.5 mm²
 24 - 16 AWG

**UL note:**

Use copper wire that is approved up to 75°C.

Supported stop category according to EN 60204

0
 1 in error-free state

Mechanical requirements

Vibration according to IEC 60068-2-6

10 - 57 Hz: 0.35 mm with constant amplitude
 57 - 150 Hz; 5g acceleration, constant amplitude

Shock according to IEC 60068-2-27

30g over 11 ms, Criterion A

Safety characteristic data according to EN 61508

Achievable SIL

SIL 2 (single-channel)
 SIL 3 (two-channel)
 Depends on the parameterization and wiring; see Section 2.5 "Connection options for actuators depending on the parameterization" on page 16, see Section 6 "Connection examples for safe outputs" on page 39

Probability of a dangerous failure on demand by the safety function (PFD)

For single-channel assignment

1% of 10⁻², maximum (corresponds to 1 x 10⁻⁴)

For two-channel assignment

1% of 10⁻³, maximum (corresponds to 1 x 10⁻⁵)

Probability of a dangerous failure per hour for the entire module (PFH)

Depends on the parameterization

For single-channel assignment

1% of 10⁻⁶, maximum (corresponds to 1 x 10⁻⁸)

For two-channel assignment

1% of 10⁻⁷, maximum (corresponds to 1 x 10⁻⁹)

Hardware fault tolerance (HFT) of the module

1

Permissible duration of use

20 years, 25 years with a low demand rate

Safety characteristic data according to EN 62061

Achievable SIL claim limit

SILCL 2 (single-channel)
 SILCL 3 (two-channel)
 Depends on the parameterization and wiring; see Section 2.5 "Connection options for actuators depending on the parameterization" on page 16, see Section 6 "Connection examples for safe outputs" on page 39

Safe failure fraction (SFF)

99%

Probability of a dangerous failure per hour for the entire module (PFH)

Depends on the parameterization

For single-channel assignment

1% of 10⁻⁶, maximum (corresponds to 1 x 10⁻⁸)

For two-channel assignment

1% of 10⁻⁷, maximum (corresponds to 1 x 10⁻⁹)

Hardware fault tolerance (HFT) of the module

1

Permissible duration of use

20 years, 25 years with a low demand rate
 Operation in the error state: 72 h

Safety characteristic data according to EN ISO 13849-1

Achievable performance level	PL d (single-channel) PL e (two-channel) Depends on the parameterization and wiring; see Section 2.5 "Connection options for actuators depending on the parameterization" on page 16, see Section 6 "Connection examples for safe outputs" on page 39
Diagnostic coverage (DC)	99%
Mean time to dangerous failure (MTTFd)	100 years

Supply voltage U_{BUS} (logic)

The bus coupler or a feed-in terminal in the station supply the module with communications power U_{BUS} . For the technical data, please refer to the data sheet for the bus coupler or the feed-in terminal.

Communications power	5 V DC
Current consumption from U_{BUS}	260 mA, typical (all outputs set; supply by U_O of 19.2 V DC to 30.2 V DC) 280 mA, maximum

Supply voltage U_O (actuators)**WARNING: Loss of safety function**

The use of unsuitable power supplies can result in the loss of the safety function.

- Use power supplies according to EN 50178/VDE 0160 (PELV).

Nominal voltage	24 V DC according to EN 61131-2 and EN 60204
Ripple	3.6 V _{PP}
Permissible voltage range	19.2 V DC to 30.2 V DC (including all tolerances, ripple included)
Current consumption	25 mA, typical (all outputs set, supply by U_O with 30.2 V DC; without supply to the actuators)
Permissible interrupt time	10 ms Within this time, the output voltage for the safe outputs fails as the outputs are not internally buffered.
Surge protection	Yes (in the module)
Protection against polarity reversal	Yes (in the module)

**NOTE: Module damage**

Parallel protection against polarity reversal is only implemented in the module for a limited period. The following measures must be taken to prevent damage to the module:

- Due to the maximum current carrying capacity of 8 A, protect power supply U_O externally with an 8 AT fuse.
- Only use PELV power supply units with at least four times the nominal tripping current, as this is the only way to ensure tripping times of less than 300 ms.

Undervoltage detection	Yes, at approximately 17 V
Diagnostics indicators	Green U_O LED: see Section 2.6 "Local diagnostics and status indicators" on page 17
External protection	8 A slow-blow, maximum

Safe digital outputs

Quantity	4 two-channel or 8 single-channel (positive switching)
Supply	From supply voltage U_O
Maximum output current per output (channel)	2 A 1.5 A (from 45°C according to CUL _{US})

AXL F SSSD08/3 1F

Safe digital outputs

Maximum output current for all outputs (total current)	8 A 6 A (from 45°C according to CUL _{US})
Maximum output current for each group (total current)	
Group 1 (OUT0_K1, OUT1_K1, OUT2_K1, OUT3_K1)	4 A 3 A (from 45°C according to CUL _{US})
Group 2 (OUT0_K2, OUT1_K2, OUT2_K2, OUT3_K2)	4 A 3 A (from 45°C according to CUL _{US})
Maximum output voltage in the low state	< 5 V



WARNING: Loss of safety function

The use of unsuitable power supplies can result in the loss of the safety function.

- Only use power supplies according to EN 50178/VDE 0160 (PELV) for the voltage supply.
- Make sure that the output voltage of the power supply does not exceed 32 V even in the event of an error.
- Observe the general safety notes: see Section 1.2 "Electrical safety" on page 10.

Maximum leakage current in the low state	2 mA
--	------



WARNING: Loss of safety function

Switching the load at the maximum leakage current can result in the loss of the safety function.

- Please note that at this current, the load must not switch to or remain in the ON state.
- Please take this into consideration when selecting the actuator.

Minimum withstand voltage of the connected loads	> 5 V
--	-------



WARNING: Loss of safety function

Switching the load at the minimum withstand voltage can result in the loss of the safety function.

- Please note that at this voltage, the load must not be switched or remain in the ON state.
- Please take this into consideration when selecting the actuator.

Maximum inductive load	1 H
Maximum capacitive load	10 µF per channel 10 µF in total
Minimum load	1.5 kΩ (16 mA at 24 V)
Limitation of the voltage induced on circuit interruption	-15 V
Output voltage	U _O - 1 V, approximately
Simultaneity	100% 75% (from 45°C according to CUL _{US})
Maximum switching frequency	1 Hz; 0.2 Hz at > 1 A
Filter time	None
Switch-off delay for shutdown according to stop category 1	250 ms / 500 ms / 1 s / 2 s / 4 s / 8 s / 16 s / 32 s / 64 s / 128 s Accuracy: ±5% of the set value see Section 5.2 "Parameterization of the safe outputs" on page 36
Maximum duration of the test pulses (when switched off; active driving)	1 ms



WARNING: Loss of safety function

The switch-on pulse can result in the loss of the safety function.

- Please note that the load on a switch-on pulse (light test) of 1 ms must not fail or respond in a safety-critical way.
- Please take this into consideration when selecting the actuator.

Maximum duration of the test pulses (when switched on)	3 ms (depending on the load capacity)
--	---------------------------------------

Safe digital outputs

WARNING: Loss of safety function

The switch-off pulse can result in the loss of the safety function.

- Please note that the load on a switch-off pulse (dark test) of 3 ms must not fail or respond in a safety-critical way.
- Please take this into consideration when selecting the actuator.

Status indicators

One green LED per output
see Section 2.6 "Local diagnostics and status indicators" on page 17

Diagnostics indicators

One red LED per output
see Section 2.6 "Local diagnostics and status indicators" on page 17

WARNING: Loss of safety function

Parasitic voltages can result in the loss of the safety function.

- Connect the actuator ground to the ground terminal point of the corresponding output on the Axioline F connector. An external ground may not be used.
- The connected load must not respond in a hazardous way to test pulses.

Approvals

For the latest approvals, please visit phoenixcontact.net/products.

10.3 Conformance with EMC Directive

Conformance with EMC Directive 2014/30/EU

Noise immunity test according to DIN EN 61000-6-2

Electrostatic discharge (ESD)	EN 61000-4-2 (IEC 61000-4-2)	Criterion A 6 kV contact discharge, 8 kV air discharge
Electromagnetic fields	EN 61000-4-3 (IEC 61000-4-3)	Criterion A, field strength 10 V/m
Fast transients (burst)	EN 61000-4-4 (IEC 61000-4-4)	Criterion A, test voltage 2 kV
Transient overvoltage (surge)	EN 61000-4-5 (IEC 61000-4-5)	Test intensity 2, Criterion A DC supply lines: 0.5 kV/0.5 kV (symmetrical/asymmetrical) Signal lines: 1.0 kV/2.0 kV (symmetrical/asymmetrical)
Conducted disturbance variables	EN 61000-4-6 (IEC 61000-4-6)	Criterion A, test voltage 10 V

Noise emission test according to DIN EN 61000-6-3

Noise emission	EN 55022	Class B, residential
----------------	----------	----------------------

AXL F SSD08/3 1F

10.4 Ordering data: module

Description	Type	Order No.	Pcs./Pkt.
Axioline F module with safe digital outputs	AXL F SSD08/3 1F	2702264	1

10.5 Download data: software



Make sure you always use the latest software. The software can be downloaded free of charge at phoenixcontact.net/products.

Description	Type	Download area for Order No.
SAFECONF		
Configuration software for SafetyBridge technology and Trisafe modules	SAFECONF	2986119
STARTUP+		
Software for starting up and parameterizing Axioline stations	STARTUP+	2700636

10.6 Download data: documentation



Make sure you always use the latest documentation. It can be found in the download area for the specified product at phoenixcontact.net/products.

Description	Type	Download area for Order No.
Axioline F		
User manual Axioline F: system and installation	UM EN AXL F SYS INST	2702264
User manual Axioline F: diagnostic registers and error messages	UM EN AXL F SYS DIAG	2702264
SafetyBridge		
User manual: Axioline F module with integrated safety logic and safe digital outputs	UM EN AXL F LPSD08/3 1F	2702171
SafetyBridge technology integration package for controllers from Phoenix Contact, Rockwell and Siemens (S7-1200 as of CPU 1214C, S7-1500, S7-300), Schneider as well as CODESYS-based controllers.	SBT_V3_PLC_Integration_Packages_1.8.exe	2702171



The SafetyBridge V3 integration package contains various quick start guides for integrating the SafetyBridge system with different controllers.

A Appendix: checklists

The checklists listed in this section provide support when carrying out the following tasks on the AXL F SSD08/3 1F module: planning, assembly and electrical installation, startup, parameterization, and validation.



These checklists may be used as planning documentation and/or as verification to ensure the steps in the specified phases are carried out carefully.

Archive the completed checklists to use as reference for recurring tests.

The checklists do not replace the validation, initial startup, and regular testing performed by qualified personnel.

The following section of a checklist shows an example of a completed checklist.

Checklist ...				
Device type/equipment identification		AXL F SSD08/3 1F / BK20NA10		
Version: HW/FW	00/101	Date	2008-01-03	
Test engineer 1	John Smith	Test engineer 2	Jane Brown	
Comment	System XXX has been checked for engine hood production			
No.	Requirement (mandatory)	Yes	Comment	
X	...	<input type="checkbox"/>		
No.	Requirement (optional)	Yes	No	Comment
Y	...	<input type="checkbox"/>	<input type="checkbox"/>	

Key:

Equipment identification	Enter the device type and/or the equipment identification for the relevant module.
Version: HW/FW	Enter the hardware and firmware version of the module.
Date	Enter the date on which you began to fill in this checklist.
Editor	Enter the name of the editor.
Test engineer	Enter the name of the test engineer.
Comment	Where necessary, enter a comment.
Requirement (mandatory)	These requirements must be met for a safety application, in order to complete the relevant phase using the checklist.
Requirement (optional)	These requirements are optional. For points that are not met, please enter an appropriate comment in the relevant field.

AXL F SSD08/3 1F

A 1 Planning

Checklist for planning the use of the module				
Device type/equipment identification				
Version: HW/FW		Date		
Test engineer 1		Test engineer 2		
Comment				
No.	Requirement (mandatory)	Yes	Comment	
1	Has the current module user manual been used as the basis for planning?	<input type="checkbox"/>	Revision:	
2	Are the actuators approved for connection to the module (according to the technical data and parameterization options)?	<input type="checkbox"/>		
3	Has the power supply been planned according to the specifications for the protective extra-low voltage in accordance with PELV?	<input type="checkbox"/>		
4	Has the power supply of U_O and U_{BK} from a power supply unit been planned?	<input type="checkbox"/>		
5	Is external protection of the module planned (according to the specifications in this user manual for supply voltage U_O)?	<input type="checkbox"/>		
6	Are measures planned to prevent simple tampering?	<input type="checkbox"/>		
7	Are measures planned to prevent connectors being mixed up?	<input type="checkbox"/>		
8	Are requirements for the actuators and cable installation observed according to the SIL/SILCL/Cat./PL to be achieved and is the implementation planned?	<input type="checkbox"/>		
9	Are the specifications for the parameterization for each channel defined?	<input type="checkbox"/>		
10	Have test intervals been defined for testing the shutdown capability of the actuators, if this is required to achieve a SIL/SILCL/Cat./PL?	<input type="checkbox"/>		
11	Has it been ensured that any person intentionally starting hazardous movements can only do so with a direct view of the danger zone?	<input type="checkbox"/>		
12	Does the planned use correspond to the intended use?	<input type="checkbox"/>		
13	Are the ambient conditions as well as the maximum mechanical load observed according to the technical data?	<input type="checkbox"/>		
14	Have test intervals been defined and has the maximum duration of use been taken into consideration?	<input type="checkbox"/>		
15	Has the switch-off delay for stop category 1 been observed in the calculation of the total response time for the machine/system?	<input type="checkbox"/>		
No.	Requirement (optional)	Yes	No	Comment
16	Have specifications for assembly and electrical installation been defined (e.g., EPLAN) and communicated to the relevant personnel?	<input type="checkbox"/>	<input type="checkbox"/>	
17	Have specifications for startup been defined and communicated to the relevant personnel?	<input type="checkbox"/>	<input type="checkbox"/>	
		Date		Signature (editor)
		Date		Signature (test engineer)

A 2 Assembly and electrical installation

Checklist for assembly and electrical installation of the module			
Device type/equipment identification			
Version: HW/FW		Date	
Editor		Test engineer	
Comment			
No.	Requirement (mandatory)	Yes	Comment
1	Was assembly completed according to the specifications (specifications from the planning phase or according to the user manual)?	<input type="checkbox"/>	
2	Was the module installed in the control cabinet (IP54) and secured correctly?	<input type="checkbox"/>	
3	Do the cable cross sections and installation correspond to the specifications?	<input type="checkbox"/>	
4	Does the connection technology correspond to the specifications in the technical data and in the relevant user manual?	<input type="checkbox"/>	
5	Is the address switch set correctly according to the specifications?	<input type="checkbox"/>	
		Date	Signature (editor)
		Date	Signature (test engineer)

AXL F SSD08/3 1F

A 3 Startup and parameterization

Checklist for startup and parameterization of the module				
Device type/equipment identification				
Version: HW/FW		Date		
Editor		Test engineer		
Comment				
No.	Requirement (mandatory)	Yes	Comment	
1	Was startup completed according to the specifications (specifications from the planning phase or according to the user manual)?	<input type="checkbox"/>		
2	During startup, is it ensured that any person starting hazardous movements intentionally can only do so with a direct view of the danger zone?	<input type="checkbox"/>		
3	Are all parameters parameterized for the outputs and is the F_WD_Time set correctly?	<input type="checkbox"/>		
4	For outputs that are parameterized for two-channel operation, are both channels parameterized correctly for each other?	<input type="checkbox"/>		
5	Are the output test pulses parameterized according to the actuator to be connected?	<input type="checkbox"/>		
6	Has the switch-off delay for stop category 1 been observed in the calculation of the total response time for the machine/system?	<input type="checkbox"/>		
No.	Requirement (optional)	Yes	No	Comment
7	Have safety distances that must be observed been calculated according to the response and delay times implemented?	<input type="checkbox"/>	<input type="checkbox"/>	
		Date	Signature (editor)	
		Date	Signature (test engineer)	

A 4 Validation

Checklist for validating the module			
Device type/equipment identification			
Version: HW/FW		Date	
Editor		Test engineer	
Comment			
No.	Requirement (mandatory)	Yes	Comment
1	Have all the mandatory requirements for the "Planning" checklist been met?	<input type="checkbox"/>	
2	Have all the mandatory requirements for the "Assembly and electrical installation" checklist been met?	<input type="checkbox"/>	
3	Have all the mandatory requirements for the "Startup and parameterization" checklist been met?	<input type="checkbox"/>	
4	Does the parameterization of the safe outputs correspond to the version and the actual connection of the controlled devices?	<input type="checkbox"/>	
5	Has the assignment of the actuators to the outputs and the variables of the safe application program been tested (online status in SafetyProg)?	<input type="checkbox"/>	
6	Has a function test been performed to check all safety functions in which the module is involved?	<input type="checkbox"/>	
7	Have measures been taken to achieve a specific Cat.?	<input type="checkbox"/>	
8	Do all cables correspond to the specifications?	<input type="checkbox"/>	
9	Does the power supply correspond to the specifications for the protective extra-low voltage in accordance with PELV?	<input type="checkbox"/>	
10	Has the power supply of U_O and U_{BK} in the Axioline F system from a power supply unit been implemented?	<input type="checkbox"/>	
11	Is external protection of the module implemented (according to the specifications in this user manual for supply voltage U_O)?	<input type="checkbox"/>	
12	Have measures been taken to prevent simple tampering?	<input type="checkbox"/>	
13	Are requirements for the actuators and cable installation observed according to the SIL/SILCL/Cat./PL to be achieved?	<input type="checkbox"/>	
14	Are the specifications for the parameterization for each channel implemented?	<input type="checkbox"/>	
15	Have test intervals been defined for testing the shutdown capability of the actuators, if this is required to achieve a SIL/SILCL/Cat./PL?	<input type="checkbox"/>	
16	Has it been ensured that any person intentionally starting hazardous movements can only do so with a direct view of the danger zone?	<input type="checkbox"/>	
		Date	Signature (editor)
		Date	Signature (test engineer)

AXL F SSD08/3 1F

B Appendix: index

A

Abbreviations	12
Actuators	
Connection options	16
Requirements	15
Assembly	31, 33
Bus base module.....	31
Connector.....	32
Electronics module.....	31
Instructions.....	29
Location.....	29

C

Conformance with EMC Directive	67
Connection examples	39
Current carrying capacity	25

D

Decommissioning	61
Device errors	
Outputs.....	20
Serious errors.....	20
Diagnostics indicators	17
Directives	11
Disposal	61
Documentation, latest	12

E

Enable.....	21
Errors	
Acknowledgment.....	53

F

Failure state	20
Feedback data	21
Freewheeling circuit.....	41

H

Housing dimensions	14
--------------------------	----

I

Indicators, diagnostics and status	17
Initial startup.....	49
Insulation rating.....	10

M

Maintenance	61
-------------------	----

O

Operating time	19
Ordering data.....	63
Outputs	15
Device errors.....	20
I/O errors	19
Parameterization	36
Positive switching.....	15
Requirements for actuators	15
Single-channel assignment	15
Two-channel assignment	15

AXL F SSD08/3 1F

P

Parameterization	35
Outputs	36
Single-channel	36
Two-channel	36
Parameterization errors	20
PELV	10, 25, 66
Power supply units	10
Protective circuit	41

Q

Qualified personnel	9
---------------------------	---

R

Removal	31
Repair	61
Replacement, module	51
Restart	51

S

Safe state	19
Error detection in I/O devices	19
Operating state	19
Outputs	19, 20
Safety notes	9
SafetyBridge	
Address	35
Standards	11
Startup	49
Startup mode	50
Status indicators	17
Stop category 1	37
Supply voltage	
UO	26

T

Test pulses	15, 36
Transmission speed	
Setting	30

U

Use, intended	11
---------------------	----

V

Validation	51
------------------	----

C Appendix: revision history

Revision	Date	Contents
00	2016-03-22	First publication
01	2016-11-10	HW/FW revision updated EMC Directive updated
		page 2 page 67

AXL F SSD08/3 1F



SCATTERGOOD & JOHNSON LTD

ELECTRICAL ENGINEERING & FLUID CONTROL DISTRIBUTORS

Est.1899

At Scattergood & Johnson Ltd, we pride ourselves on being a technical distributor to specialist industries.

Working with a range of quality product suppliers across a number of specialist markets, we are not your average 'box shifter' - we are your technical and supply chain partner.

We fully support every product we sell - for free! Our internal team and external sales engineers can answer any product or application question, no matter the complexity.

Backing up this technical ability is a range of 50,000+ products available from stock for nationwide next day delivery (same day if required!), or you can collect what you need from any of our trade counters around the UK.

Select your specialist interest below to learn more about how we can help.

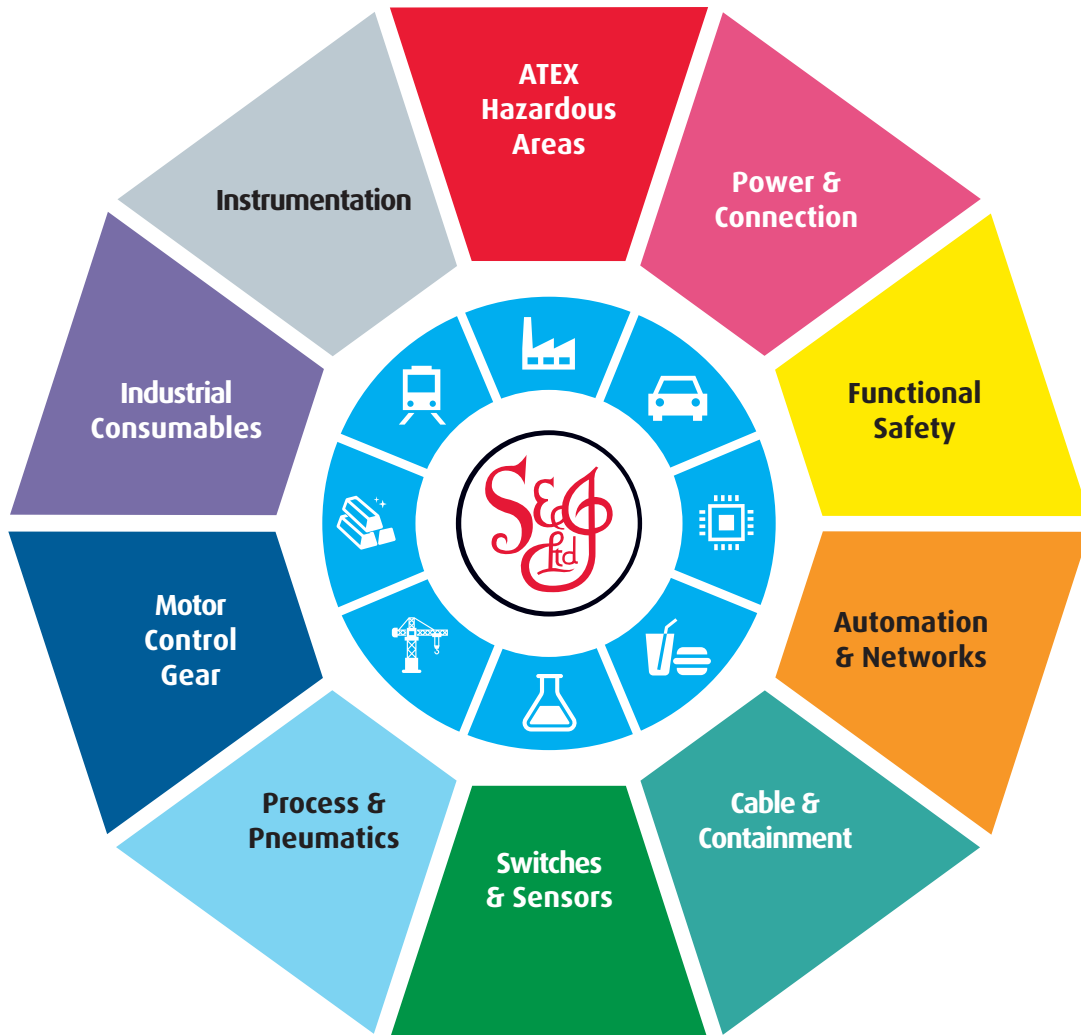

Online, In Branch and On the Road - Scattergood & Johnson Ltd, there when you need us.

www.scatts.co.uk