

# IL EC BK-PAC

**Inline, bus coupler for EtherCAT®  
bus interface: RJ45 socket**

Data sheet  
107149\_en\_05

© PHOENIX CONTACT 2018-07-05



## 1 Description

The bus coupler is intended for use within an EtherCAT® network and represents the link to the Inline I/O system. Up to 63 Inline devices can be connected to the bus coupler. EtherCAT® is a registered trademark and patented technology, licensed by Beckhoff Automation GmbH, Germany.

A corresponding ESI file is available for integrating the Inline station into the programming system.

This file can be downloaded via the product at [phoenixcontact.net/products](http://phoenixcontact.net/products).

### Features

- 2 RJ45 connections
- Automatic addressing
- Station mapped as a modular EtherCAT® device using a modular device profile (MDP)
- Acyclic data communication (mailbox protocols)
- SafetyBridge V3 supported
- Firmware can be updated

### Abbreviations used

CoE	CAN application protocol over EtherCAT®
FoE	File access over EtherCAT®



This data sheet is only valid in association with the IL SYS INST UM E user manual.



Make sure you always use the latest documentation.

It can be downloaded at: [phoenixcontact.net/product/2702507](http://phoenixcontact.net/product/2702507)

<b>2</b>	<b>Table of contents</b>	
1	Description .....	1
2	Table of contents .....	2
3	Ordering data .....	3
4	Technical data .....	4
5	UL notes .....	7
6	Safety note .....	7
7	Internal circuit diagram .....	8
8	Connecting EtherCAT® and supply .....	9
	8.1 Connecting EtherCAT® .....	9
	8.2 Connecting the supply voltage .....	10
9	Local diagnostic and status indicators .....	11
10	Reset button .....	12
	10.1 Restarting the bus coupler .....	12
	10.2 Restoring the default settings .....	12
11	Parameter data .....	13
12	Substitute value behavior .....	13
13	Synchronizing the application .....	13
14	Object dictionary .....	14
	14.1 CoE standard objects .....	15
	14.2 Module-specific CoE objects .....	16
	14.3 Objects for access to PCP objects (tunnel objects) .....	17
	14.4 Objects for local bus diagnostics .....	19
	14.5 Objects for bus coupler configuration .....	21
15	Process data .....	24
	15.1 Process data of the bus coupler .....	24
	15.2 Process data of the local bus modules .....	24
16	Diagnostics strategy .....	25
	16.1 Mechanisms .....	25
	16.2 EtherCAT® state machine .....	26
	16.3 Emergency messages .....	27
	16.4 Diagnosis history 10F3hex .....	29
17	SafetyBridge .....	30
18	Firmware update .....	30

### 3 Ordering data

Description	Type	Order No.	Pcs./Pkt.
Inline, Bus coupler, EtherCAT®, RJ45 socket, transmission speed in the local bus: 500 kbps / 2 Mbps, degree of protection: IP20 (per manufacturer's declaration), including Inline connector and labeling field	IL EC BK-PAC	2702507	1
Accessories	Type	Order No.	Pcs./Pkt.
Labeling field, width: 12.2 mm (Marking)	IB IL FIELD 2	2727501	10
Insert strip, Sheet, white, unlabeled, can be labeled with: Office printing systems: Laser printer, mounting type: insert, lettering field size: 62 x 10 mm (Marking)	ESL 62X10	0809492	1
Quick mounting end clamp for NS 35/7,5 DIN rail or NS 35/15 DIN rail, with marking option, with parking option for FBS...5, FBS...6, KSS 5, KSS 6, width: 5.15 mm, color: gray (Mounting)	CLIPFIX 35-5	3022276	50
Quick mounting end clamp for NS 35/7,5 DIN rail or NS 35/15 DIN rail, with marking option, width: 9.5 mm, color: gray (Mounting)	CLIPFIX 35	3022218	50
RJ45 connector, shielded, with bend protection sleeve, 2 pieces, gray for straight cables, for assembly on site. For connections that are not crossed, it is recommended that you use the connector set with gray bend protection sleeve. (Connector/Adapter)	FL PLUG RJ45 GR/2	2744856	1
RJ45 connector, shielded, with bend protection sleeve, 2 pieces, green for crossed cables, for assembly on site. For connections that are crossed, it is recommended that the connector set with green bend protection sleeves is used. (Connector/Adapter)	FL PLUG RJ45 GN/2	2744571	1
CAT5-SF/UTP cable (J-02YS(ST)C HP 2 x 2 x 24 AWG), heavy-duty installation cable, 2 x 2 x 0.22 mm <sup>2</sup> , solid conductor, shielded, outer sheath: 7.8 mm diameter, inner sheath: 5.75 mm ± 0.15 mm diameter (Cable/conductor)	FL CAT5 HEAVY	2744814	1
CAT5-SF/UTP cable (J-LI02YS(ST)C H 2 x 2 x 26 AWG), light-duty, flexible installation cable 2 x 2 x 0.14 mm <sup>2</sup> , stranded, shielded, outer sheath: 5.75 mm ± 0.15 mm diameter (Cable/conductor)	FL CAT5 FLEX	2744830	1
Crimping pliers, for assembling the RJ45 plugs FL PLUG RJ45..., for assembly on site (Tools)	FL CRIMPTOOL	2744869	1
Fine surge protection in accordance with Class D (CAT5), for token ring, ISDN, DS1, Ethernet, and Power over Ethernet (PoE) "Mode A" and "Mode B". RJ45 attachment plug with separate grounding cable and snap-on foot for NS 35 DIN rails.	D-LAN-CAT.5-FP	2800723	1

Documentation	Type	Order No.	Pcs./Pkt.
User manual, English, Automation terminals of the Inline product range	IL SYS INST UM E	-	-
Application note, German/English, I/O modules at bus couplers	AH IL BK IO LIST	-	-
Application note, English, IL EC BK-PAC bus coupler: access to PDI objects and startup parameterization	AH EN IL EC BK-PAC - TUNNEL	-	-
Application note, English, Firmware update on the AXL F BK EC or IL EC BK-PAC bus coupler with TwinCAT®	AH EN FIRMWARE UPDATE AXL F BK EC / IL EC BK-PAC	-	-

## 4 Technical data

### Dimensions (nominal sizes in mm)

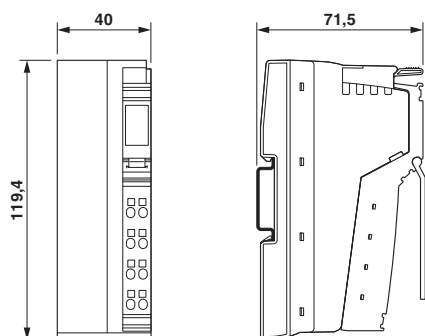

Width	40 mm
Height	119.4 mm
Depth	71.5 mm
Note on dimensions	Housing dimensions

### General data

Color	green
Weight	118 g (with connectors)
Ambient temperature (operation)	-25 °C ... 55 °C
Ambient temperature (storage/transport)	-40 °C ... 85 °C
Permissible humidity (operation)	10 % ... 95 % (non-condensing)
Permissible humidity (storage/transport)	10 % ... 95 % (non-condensing)
Air pressure (operation)	70 kPa ... 106 kPa (up to 3000 m above sea level)
Air pressure (storage/transport)	70 kPa ... 106 kPa (up to 3000 m above sea level)
Degree of protection	IP20 (per manufacturer's declaration)
Protection class	III, IEC 61140, EN 61140, VDE 0140-1

**Connection data: Inline connector**

Connection method	Spring-cage connection
Conductor cross section solid / stranded	0.08 mm <sup>2</sup> ... 1.5 mm <sup>2</sup> / 0.08 mm <sup>2</sup> ... 1.5 mm <sup>2</sup>
Conductor cross section [AWG]	28 ... 16
Stripping length	8 mm

**Connection data for UL approvals: Inline connector**

Connection method	Spring-cage connection
Conductor cross section solid / stranded	0.2 mm <sup>2</sup> ... 1.5 mm <sup>2</sup> / 0.2 mm <sup>2</sup> ... 1.5 mm <sup>2</sup>
Conductor cross section [AWG]	24 ... 16
Stripping length	8 mm

**Interface: EtherCAT®**

Connection method	RJ45 socket
Note on the connection method	Auto negotiation and autocrossing
Transmission speed	100 Mbps (Full duplex)
Cycle Time	100 μs
Transmission physics	Ethernet in RJ45 twisted pair

**Interface: Inline local bus**

Connection method	Inline data jumper
Transmission speed	500 kbps / 2 Mbps (automatic detection, no combined system)

**System limits of the bus coupler**

Number of supported devices	max. 63 (per station)
Number of local bus devices that can be connected	max. 63
Number of devices with parameter channel	max. 16



Observe the logic current consumption of each device when configuring an Inline station! It is specified in every terminal-specific data sheet. The current consumption can differ depending on the individual terminal. The permissible number of devices that can be connected therefore depends on the specific station structure.

**EtherCAT®**

Mailbox protocols	CAN application protocol over EtherCAT®, File access over EtherCAT®
Type of addressing	Auto-increment addressing Fixed position addressing Logical addressing
Specification	ETG.1000 V1.02

**Bus coupler supply U<sub>BC</sub>; Communications power U<sub>L</sub> (7.5 V) and the analog supply U<sub>ANA</sub> (24 V) are generated from the bus coupler supply.**

Supply voltage	24 V DC (via Inline connector)
Supply voltage range	19.2 V DC ... 30 V DC (including all tolerances, including ripple)
Current draw	typ. 70.6 mA (No local bus devices connected) max. 0.9 A (with max. number of connected I/O terminal blocks)

**Communications power ( $U_L$ )**

Supply voltage	7.5 V DC
Power supply unit	max. 0.8 A

**Supply of analog modules ( $U_{ANA}$ )**

Supply voltage	24 V DC
Supply voltage range	19.2 V DC ... 30 V DC (including all tolerances, including ripple)
Power supply unit	max. 0.5 A DC

**Main circuit supply ( $U_M$ )**

Supply voltage	24 V DC
Supply voltage range	19.2 V DC ... 30 V DC (including all tolerances, including ripple)
Power supply unit	max. 8 A DC (sum of $U_M + U_S$ )

**Segment circuit supply ( $U_S$ )**

Supply voltage	24 V DC
Supply voltage range	19.2 V DC ... 30 V DC (including all tolerances, including ripple)
Power supply unit	max. 8 A DC (sum of $U_M + U_S$ )

**Power consumption**

Power consumption	typ. 1.7 W (entire device)
-------------------	----------------------------

**Protection****NOTE: Electronics may be damaged when overloaded**

Provide external protection for the 24 V areas  $U_{BK}$ ,  $U_M$ , and  $U_S$ . If you are using an external fuse, the power supply unit must be able to supply four times the nominal current of the fuse. This ensures that it trips in the event of an error.

**Error messages to the higher level control or computer system**

Messages via object 10F3<sub>hex</sub> Diagnosis history

**Approvals**

For the latest approvals, please visit [phoenixcontact.net/products](http://phoenixcontact.net/products).

## 5 UL notes

- If the device is used in a manner not specified, the protection provided by the device may be impaired.
- Modifications to the hardware of the device are not permitted. Do not repair the device yourself. If the device is defective, please contact Phoenix Contact.
- Minimum temperature rating of the cables to be connected to the field wiring terminals: 75°C
- Use copper conductor only.
- The device is designed exclusively for operation with safety extra-low voltage (SELV/PELV) in accordance with IEC 60950 / EN 60950 / VDE 0805.
- The device has to be built in the final safety enclosure, which has adequate rigidity according to UL 61010-1, UL 61010-2-201 and meets the requirements with respect to spread of fire.

## 6 Safety note

**NOTE: Risk of unauthorized network access**

To prevent unauthorized network access, please read the following notes.

Connecting devices to a network via Ethernet entails the danger of unauthorized access to the network.

If possible, deactivate unused communication channels.

Assign passwords such that third-parties cannot access the bus coupler and make changes without authorization.

Due to its communication interfaces, the bus coupler should not be used in safety-critical applications without additional security appliances.

Therefore, please take additional protective measures in accordance with the IT security requirements and the standards applicable to your application (e.g. virtual networks (VPN) for remote maintenance access, firewalls, etc.) for protection against unauthorized network access.

On first request, you shall release Phoenix Contact and the companies associated with Phoenix Contact GmbH & Co. KG, Flachsmarktstrasse 8, 32825 Blomberg in accordance with §§ 15 ff. AktG (German Stock Corporation Act), hereinafter collectively referred to as "Phoenix Contact", from all third-party claims made due to improper use.

For the protection of networks for remote maintenance via VPN, Phoenix Contact offers the mGuard product series as security appliances; these are described in the latest Phoenix Contact catalog ([phoenixcontact.net/products](http://phoenixcontact.net/products)).

Additional measures for protection against unauthorized network access can be found in the

AH EN INDUSTRIAL SECURITY application note. The application note can be downloaded at [phoenixcontact.net/products](http://phoenixcontact.net/products).

## 7 Internal circuit diagram

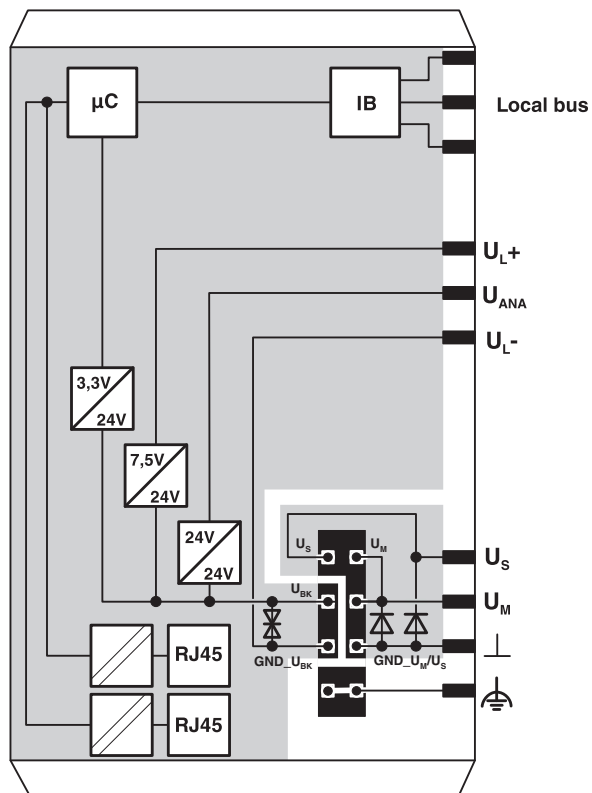









Figure 1 Internal wiring of connections

Key:

-  Microcontroller
-  Protocol chip
-  Power supply unit
-  Power supply unit with electrical isolation
-  RJ45 interface
-  Electrically isolated area

 Please refer to the IL SYS INST UM E user manual for an explanation of other symbols used.

## 8 Connecting EtherCAT<sup>®</sup> and supply

### 8.1 Connecting EtherCAT<sup>®</sup>

Connect EtherCAT<sup>®</sup> to the bus coupler via an 8-pos. RJ45 connector.

The EtherCAT<sup>®</sup> connections are directional.

Designation	Direction	Note
X1	IN	Connecting the cable from the master.
X2	OUT	Connecting the cable to additional slaves.

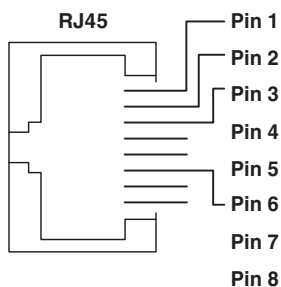

Figure 2 Pin assignment of the Ethernet sockets (RJ45)

For the pin assignment, refer to the following table:

Pin	Assignment
1	TxD + (transmit data +)
2	TxD - (transmit data -)
3	RxD+ (receive data +)
4	Reserved
5	Reserved
6	RxD- (receive data -)
7	Reserved
8	Reserved



**Auto crossover**  
Both Ethernet interfaces are provided with the auto crossover function.



**Shielding**  
The shielding ground of the connected twisted pair cables is electrically connected with the socket. When connecting network segments, avoid ground loops, potential transfers, and voltage equalization currents via the braided shield.



**Observe bending radii**  
The housing dimensions specified under "Dimensions" refer to the bus coupler with I/O connectors without Ethernet connection. When installing the bus coupler in a control box, observe the bending radii of the Ethernet cables and the connectors used (e.g., FL CAT5 FLEX: 30 mm for fixed installation and FL CAT5 HEAVY: 30 mm without outer sheath and 45 mm with outer sheath). If required, use angled RJ45 connectors to maintain these bending radii.

## 8.2 Connecting the supply voltage

Connect the supply using the Inline connector included in the scope of supply.

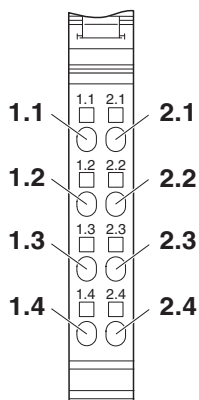

Figure 3 Terminal point assignment

1.1	$U_S$ (24 V DC)	24 V supply for segment circuit
1.2	$U_{BK}$ (24 V DC)	24 V bus coupler supply/7.5 V logic power supply/24 V analog power supply
2.1, 2.2	$U_M$ (24 V DC)	24 V supply for main circuit
1.3	GND $U_{BK}$	Ground
2.3	GND $U_M/U_S$	Ground
1.4, 2.4	FE	Functional earth ground



**NOTE: Module damage due to overload**

Make sure that the maximum total current flowing through the potential jumpers is 8 A.



For information on the power supplies, please refer to the IL SYS INST UM E user manual.



If you want to use the same reference potential for communications power and segment voltage, you can bridge the terminal points 1.3 and 2.3 on the connector.



Connect the functional earth ground via the power connector.

## 9 Local diagnostic and status indicators

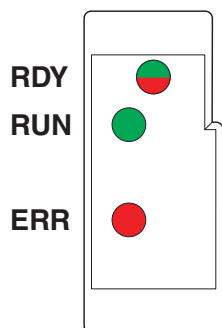

Figure 4 Local diagnostic and status indicators

Designation	Color	State	Description
RDY	Green/yellow/red	Bus coupler status	
		Green ON	Bus coupler is ready to operate.
		Flashing green/yellow	Supply voltage $U_{BK}$ is present.
			Supply voltage $U_M$ and/or $U_S$ is not present and/or overload or short circuit on $U_L$ .
		Yellow ON	Firmware/bus coupler is booting.
		Flashing green/red	Reset to default settings (reset button is held down)
		Yellow flashing	Firmware update: firmware is being flashed to bus coupler.
		Flashing yellow/red	Firmware update: incorrect firmware file loaded on the bus coupler.
		Flashing red	Faulty firmware
OFF	Bus coupler is not ready to operate. Supply voltage $U_{BK}$ is not present.		
RUN	Green	Bus coupler operating state	
		OFF	Bus coupler in Init state
		Flashing slowly (2.5 Hz)	Bus coupler in Pre-Operational state
		Single pulse	200 ms on, 1000 ms off: bus coupler in Safe-Operational state
		Flashing quickly (10 Hz)	Bus coupler in Bootstrap state
		ON	Bus coupler in Operational state
ERR	Red	Bus coupler error	
		OFF	No error
		Flashing slowly (2.5 Hz)	Configuration error, a state transition initiated by the master cannot be executed
		Single pulse	200 ms on, 1000 ms off: local application error
		Double pulse	200 ms on, 200 ms off, 200 ms on, 1000 ms off: watchdog timeout
		ON	Critical internal error

## 10 Reset button

There is a reset button on the bus coupler.

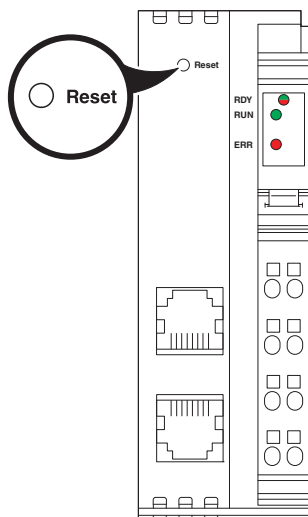

Figure 5 Reset button

The reset button has two functions:

- Restarting the bus coupler
- Resetting of the default settings

### 10.1 Restarting the bus coupler

The bus coupler is restarted when the button is pressed during operation.

The outputs of the station are reset.

The process image of the inputs is not re-read.

The bus coupler restarts.

### 10.2 Restoring the default settings

If you wish to restore the default settings, proceed as follows:

- Disconnect the power to the module.
- Press and hold the reset button.
- Switch on the power.
- Release the button when **all** the LEDs flash briefly for the **first** time (after max. 2 seconds).

During the reset process the RDY LED lights up yellow.

When the bus coupler is fully started and ready to operate, the RDY LED lights up green.



If you press the reset button too long and the LEDs flash a second time, you have exited the mode for restoring the factory settings. In this case, disconnect power to the module again and proceed as described above.

## 11 Parameter data

The CAN application protocol over EtherCAT® (CoE) mailbox protocol is the basis of the Modular Device Profile (MDP) and enables parameterization of EtherCAT® devices via the object dictionary. The object dictionary is accessed via CoE using Service Data Object (SDO) services.

Inline terminals that are configured via PCP can be configured using corresponding objects in the CoE object dictionary. Two tunnel objects are available for each Inline terminal. This are only significant for PCP devices. You can set (object 20nn<sub>hex</sub>) and read (object 30nn<sub>hex</sub>) the parameters via these tunnel objects. These tunnel objects can be used to parameterize the Inline PCP terminals in EtherCAT® system startup via the EtherCAT® engineering functionality of the StartUp or Init commands.



Configurable Inline terminals, which are not PCP devices, can be parameterized via the output process data corresponding to the data sheet.

In the event of an error in the local bus, you can parameterize whether the local bus continues to run in the remaining system or whether it enters the stop state.

Parameterize the startup behavior of the bus coupler when operating the local bus with remaining configuration via object F804<sub>hex</sub> "Startup with remaining system". See "Objects for bus coupler configuration" section.

The objects implemented on the bus coupler are described in the "Object dictionary" section.

## 12 Substitute value behavior

If EtherCAT® communication fails or an error occurs in the local bus, all Inline station outputs are set to a defined status.

Parameterize the behavior of the outputs via the F801<sub>hex</sub> object "EtherCAT® reset behavior". Refer to the Section "Objects for bus coupler configuration"

## 13 Synchronizing the application

Only the SM Synchronous mode is provided for synchronization of the application.

### SM Synchronous

In this mode, the EtherCAT® communication system and the local bus operate asynchronously. The local bus is in Auto-Run mode and runs with the minimum possible cycle time for the current module configuration.

## 14 Object dictionary

The bus coupler object dictionary contains objects which can be addressed via SDO services. These are defined in the ETG standards. Objects with a module-specific design are subsequently described in detail.

The objects are addressed using a combination of index and subindex. Subindex 0 lists the number of subindices.

The following applies for the tables below:

Meaning	Representation	Numbering starts with	
Length	Length of the elements in bytes		
Rights	Access rights		
R	Read		
W	Write		
nn	Number of the module addressed	Hexadecimal (hex)	00 for module 1
n	Number of the module addressed	Decimal (dec)	1 for module 1



Note the offset of 1 when counting the modules and the hexadecimal representation of the module number in the indices.

$$n_{\text{dec}} = nn_{\text{hex}} + 1$$

Examples:

Module in the local bus	$n_{\text{dez}}$	$nn_{\text{hex}}$
1	1	00
10	10	9
11	11	0A
33	33	20

## 14.1 CoE standard objects

Index (hex)	Name	Defined in standard
1000	Device type	ETG.1000.6
1008	Device name	ETG.1000.6
1009	Hardware version	ETG.1000.6
100A	Software version	ETG.1000.6
1018	Identify	ETG.1000.6
10F3	Diagnosis history	ETG.1020
10F8	Timestamp	ETG.1020
1C00	SyncManager type	ETG.1000.6
1C12	RxPDO assign	ETG.1000.6
1C13	TxPDO assign	ETG.1000.6
1C32	SM output parameter	ETG.1020
1C33	SM input parameter	ETG.1020
F000	Modular device profile	ETG.5001.1
F002	Detect modules command	ETG.5001.1
F030	Configured module ident list	ETG.5001.1
F050	Detected module ident list	ETG.5001.1

ETG.1000.6 Application layer protocol specification  
 ETG.1020 EtherCAT® protocol enhancements  
 ETG.5001.1 General MDP device model specification

## 14.2 Module-specific CoE objects

Index (hex)	Subindex	Object name	Data type	Length	Rights	Meaning	
16nn	01 ... 03*	Module n RxPDO Mapping		4	R	Bit 31 ... bit 16	Index of the associated output data object (e.g., 7010 <sub>hex</sub> for module 2)
						Bit 15 ... bit 8	Subindex of the associated output data object
						Bit 7 ... bit 0	Subindex length of the associated output data object
1Ann	01 ... 03*	Module n TxPDO Mapping		4	R	Bit 31 ... bit 16	Index of the associated input data object (e.g., 6010 <sub>hex</sub> for module 2)
						Bit 15 ... bit 8	Subindex of the associated input data object
						Bit 7 ... bit 0	Subindex length of the associated input data object
6nn0	01 ... 03*	Module n Inputs	Octet string	Depending on module	R	n module input process data	
7nn0	01 ... 03*	Module n Outputs	Octet string	Depending on module	R	n module output process data	
9nn0		Module n Identification				Identification of module n	E.g., module 1: 9000 <sub>hex</sub> , module 2: 9010 <sub>hex</sub> etc.
	0A	Module ident	Unsigned 32	4	R	Unique number for module identification (connection to device description)	
						Bit 31 ... bit 16	0
						Bit 15 ... bit 8	Length code
						Bit 7 ... bit 0	Module ID

\* The 02 and 03 subindices only exist for modules with a width of more than 30 bytes at the input or output process data.

### 14.3 Objects for access to PCP objects (tunnel objects)

You can access the PCP objects of the modules of a station via EtherCAT<sup>®</sup>. CoE objects 20nn<sub>hex</sub> and 30nn<sub>hex</sub> are used, with which a tunnel method can be implemented.

The CoE objects in the 2000<sub>hex</sub> to 203F<sub>hex</sub> area create PCP write access to acyclic EtherCAT<sup>®</sup> services. Once the local bus configuration has been successfully read in, for each detected local bus device, there is a CoE object, e.g., 2000<sub>hex</sub> for module 1, 2001<sub>hex</sub> for module 2, etc.

The CoE objects in the 3000<sub>hex</sub> to 303F<sub>hex</sub> area create PCP read access to acyclic EtherCAT<sup>®</sup> services. Once the local bus configuration has been successfully read in, for each detected local bus device, there is a CoE object, e.g., 3000<sub>hex</sub> for module 1, 3001<sub>hex</sub> for module 2, etc.

For I/O modules that are not PCP devices, these tunnel objects have no function. Access to this is answered with a negative confirmation with Error\_Code 00<sub>hex</sub> and Error\_Class 02<sub>hex</sub> (Feature not supported).

Index (hex)	Subindex	Object name	Data type	Length	Rights	Meaning	
20nn	00	Module n PDI Write Tunnel				Write access to the PCP objects in module n via the PCP channel Mapping to PDI write service (service code 01 <sub>hex</sub> ) at slot n	
	01	Command	Octet string	251	R/W	Data for the PCP write request	
						Byte 0	Invoke ID
						Byte 1, 2	Index PCP object
						Byte 3	Subindex PCP object
						Byte 4	Length of the data to be written
	Byte 5 ... n	User data (max. 246 bytes)					
	02	Status	Unsigned 8	1	R	Status of the last write access	
						01 <sub>hex</sub>	Last access completed successfully (positive confirmation received)
						03 <sub>hex</sub>	Last access not completed successfully (negative confirmation received)
						FF <sub>hex</sub>	Access is executed
	03	Response	Octet string	9	R	Result of the last write access Data for PDI write response The data is only valid if subindex 2 ≠ FF <sub>hex</sub>	
						Byte 0	Subslot
						Byte 1, 2	Index PCP object
						Byte 3	Subindex PCP object
						Byte 4	Length (= 0)
Positive confirmation							
Byte 5 ... 8						0	
Negative confirmation							
Byte 5						Error class	
Byte 6						Error code	
Byte 7, 8	Additional error code						

Index (hex)	Subindex	Object name	Data type	Length	Rights	Meaning	
30nn	00	Modul n PDI Read Tunnel				Read access to PCP objects in module n via the PCP channel Mapping to PDI read service (service code 00 <sub>hex</sub> ) at slot n	
	01	Command	Octet string	4	R/W	Data for PCP read request	
						Byte 0	Invoke ID
						Byte 1, 2	Index PCP object
						Byte 3	Subindex PCP object
	02	Status	Unsigned 8	1	R	Status of the last read access	
						01 <sub>hex</sub>	Last access completed successfully (positive confirmation received)
						03 <sub>hex</sub>	Last access not completed successfully (negative confirmation received)
						FF <sub>hex</sub>	Access is executed
	03	Response	Octet string	251	R	Result of the last read access Data for PCP read response The data is only valid if subindex 2 ≠ FF <sub>hex</sub>	
						Byte 0	Invoke ID
						Byte 1, 2	Index PCP object
						Byte 3	Subindex PCP object
						Positive confirmation	
						Byte 4	Length
						Byte 5, 6	0
Byte 7 ... n						Data for PCP read response	
Negative confirmation							
Byte 4						0	
Byte 5						Error class	
Byte 6						Error code	
Byte 7, 8	Additional error code						

## 14.4 Objects for local bus diagnostics

### 14.4.1 F100<sub>hex</sub>: Local bus diag info

CoE object F100<sub>hex</sub> can be used to request the status information of the local bus master.

Index (hex)	Subindex	Object name	Data type	Length	Rights	Meaning
F100	00	Local bus diag info				Read access to diagnostic information of the local bus master
	01	State	Unsigned 16	2	R	INTERBUS diagnostic status register
	02	Parameter	Unsigned 16	2	R	INTERBUS diagnostic parameter register
	03	Ext. parameter	Unsigned 16	2	R	INTERBUS extended diagnostic parameter register

The data for object F100<sub>hex</sub> is additionally provided in the cyclic input data of the Inline station, see also “Process data of the bus coupler”.

### 14.4.2 F101<sub>hex</sub>: local bus diag counters

The Inline bus coupler has multiple diagnostic counters that pertain to the local bus. Access to these statistics is via the local bus master (mapping the DDI service “Get\_Diag\_Info” with the “Global\_Count” attribute)

You can query the diagnostic counter via the CoE object F101<sub>hex</sub>.

Index (hex)	Subindex	Object name	Data type	Length	Rights	Meaning
F101	00	Local bus diag counters	Record			Access to diagnostic counter for the local bus
	01	Cycle count	Unsigned 32	4	R	Counter for INTERBUS cycles
	02	Cycle error count	Unsigned 32	4	R	Counters for faulty bus cycles
	03	ID cycle count	Unsigned 32	4	R	Counter for ID cycles
	04	ID cycle error count	Unsigned 32	4	R	Counter for faulty ID cycles
	05	Data cycle count	Unsigned 32	4	R	Counter for data cycles
	06	Data cycle error count	Unsigned 32	4	R	Counter for faulty data cycles
	07	Clear counters	Boolean	0.1	R/W	Writing any value resets the diagnostic counters.

The data for this object is not provided in the cyclic input data of the Inline station.

### 14.4.3 F102<sub>hex</sub>: local bus baud rate

You can query the current transmission speed on the local bus via the CoE object F102<sub>hex</sub>.

Index (hex)	Subindex	Object name	Data type	Length	Rights	Meaning	
F102	00	Local bus baud rate	Unsigned 8	1	R	Currently used transmission speed on the local bus	
						00 <sub>hex</sub>	2 Mbps
						01 <sub>hex</sub>	500 kbps

The data for this object is not provided in the cyclic input data of the Inline station.

#### 14.4.4 F103<sub>hex</sub>: remaining system active

You can query via the CoE object F103<sub>hex</sub> whether a remaining system was detected during startup with the currently available local bus configuration.

A remaining configuration is available if more I/O modules are expected during system startup than are physically available on the bus coupler through the EtherCAT<sup>®</sup> master.

For this detection to occur successfully, the bus coupler must be in "Validate ModuleIdent List: On" mode (CoE object F802<sub>hex</sub>).

The expected master module list must be written to the CoE object F030<sub>hex</sub>.

Index (hex)	Subindex	Object name	Data type	Length	Rights	Meaning	
F103	00	Remaining system active	Unsigned 8	1	R	Remaining system detected	
						00 <sub>hex</sub>	No remaining system was detected in startup, normal operation.
						01 <sub>hex</sub>	A remaining system was detected in startup.

The data for object F103<sub>hex</sub> is additionally provided in the cyclic input data of the Inline station, see also "Process data of the bus coupler".

## 14.5 Objects for bus coupler configuration

The bus coupler has objects which are used for the configuration of the bus coupler. Write access to these objects is only possible in the PREOP state.

The contents of the objects are stored not retentively in the bus coupler.

### 14.5.1 EtherCAT® reset behavior F801<sub>hex</sub>

With the F801<sub>hex</sub> object, you can parameterize the substitute value behavior of the outputs of the local bus devices in the event of a fault.

Index (hex)	Subindex	Object name	Data type	Length	Rights	Meaning
F801	00	EtherCAT® reset behavior	Unsigned 8	1	R/W	Parameterization of the output reset behavior
						00 (Default) All outputs are set to "0".
						01 All outputs keep the last value.

### 14.5.2 Validate module ident list F802<sub>hex</sub>

Object F802<sub>hex</sub> can be used to check the connected module configuration.

Index (hex)	Subindex	Object name	Data type	Length	Rights	Meaning
F802	00	Validate module configuration	Unsigned 8	1	R/W	Validation of the module configuration
						00 The bus coupler does not check the module configuration.
						01 (Default) During the transition from PREOP to SAFEOP, the bus coupler checks the module configuration.

In order for the module configuration to be checked, the master must write object F030<sub>hex</sub> with the expected module configuration during the state transition from PREOP to SAFEOP. If this is not done, validation is not carried out. When the object is written, it must be done so correctly and consistently. The contents of object F030<sub>hex</sub> are reset on a state transition from SAFEOP to PREOP.

If the bus coupler is configured so that the module configuration does not have to be checked, it can only be operated if the process data length of the connected modules matches the process data length of the expected modules.

### 14.5.3 Local bus auto restart F803<sub>hex</sub>

With the F803<sub>hex</sub> object, you can configure the behavior of the bus coupler when a local bus fault occurs.

Index (hex)	Subindex	Object name	Data type	Length	Rights	Meaning
F803	00	Local bus auto restart	Unsigned 8	1	R/W	Bus coupler behavior when a local bus fault occurs
					00	Wait for PREOP: The bus coupler goes into the ERR-SAFE-OP state. There is no attempt to automatically restart the local bus. Restarting the system can only be triggered by means of an ESM state transition back to PREOP and then a subsequent state transition back to OP.
					01	(Default) Auto restart: The bus coupler is trying to restart the local bus. If this is successful, the following reaction depends on whether operating the local bus is permitted with the remaining configuration. This depends on the configuration in the CoE object "Startup with remaining system", Index F804 <sub>hex</sub> .

#### 14.5.4 Startup with remaining system F804<sub>hex</sub>

With the F804<sub>hex</sub> object, you can configure the startup behavior of the bus coupler when operating the local bus with the remaining configuration.

A remaining configuration is available if more I/O modules are expected during system startup than are physically available on the bus coupler through the EtherCAT<sup>®</sup> master.

For this detection to occur successfully, the bus coupler must be in "Validate ModuleIdent List: On" mode (CoE object F802<sub>hex</sub>).

The expected master module list must be written to the CoE object F030<sub>hex</sub>.

Index (hex)	Subindex	Object name	Data type	Length	Rights	Meaning
F804	00	Startup with remaining system	Unsigned 8	1	R/W	Startup behavior of the bus coupler when operating the local bus with remaining configuration
					00	Not permitted: Startup with fewer I/O modules than expected by the master is not permitted. If the remaining configuration is detected in startup, this leads to a fault. Any status transition is terminated with an error (see diagnostics).
					01	(Default) Permitted: Startup with fewer I/O modules than expected by the master is permitted. If remaining configuration is detected during startup, the output process data of the unavailable modules is ignored by the bus coupler. "0" is transmitted for the unavailable modules in the input process data.

## 15 Process data

### 15.1 Process data of the bus coupler

In addition to the cyclic IN and OUT process data, which is defined by the connected Inline terminals, the bus coupler itself has data which is inserted in the cyclic process image. This data has a total length of 8 bytes.

In accordance with the EtherCAT® standard, this data appears before the IN process data of the first Inline terminal in the process image (SyncManager 3 bytes 0 ... 7). The objects for the corresponding PDO mapping can be found in 1AFF<sub>hex</sub>.

Process data words 1 ... 3 contain status and diagnostic information for the Inline bus coupler and can also be called via acyclic services using CoE. They appear in the form of object F100<sub>hex</sub>.

The process data contains the following information:

Word 0, byte 0							
7	6	5	4	3	2	1	0
Reserved				InputUpdateCounter		Remaining system active	New Diagnosis Message
				Counter, which is incremented after each valid local bus cycle		Mapping of the "Remaining system active" object, index F103 <sub>hex</sub> subindex 00	Mapping of the "Diagnosis history" object, index 10F3 <sub>hex</sub> subindex 04

Word 0, byte 1							
7	6	5	4	3	2	1	0
Reserved							

Word 1							
Byte 3				Byte 2			
Diagnostic status register							
Mapping of the "Local bus diag info" object, index F100 <sub>hex</sub> subindex 01							

Word 2							
Byte 5				Byte 4			
Diagnostic parameter register							
Mapping of the "Local bus diag info" object, index F100 <sub>hex</sub> subindex 02							

Word 3							
Byte 7				Byte 6			
Extended diagnostic parameter register							
Mapping of the "Local bus diag info" object, index F100 <sub>hex</sub> subindex 03							

### 15.2 Process data of the local bus modules

Depending on the data direction, a maximum process data width of 512 bytes is supported for the I/O modules' process data.

The modules' input and output process data is displayed according to their process data description.

The process data of an I/O module always begins with a full byte boundary, even for modules with process data smaller than eight bits. The unused bits are reserved.

## 16 Diagnostics strategy

### 16.1 Mechanisms

Different mechanisms are used to diagnose the bus coupler.

Mechanism		Diagnostics
EtherCAT <sup>®</sup> state machine		EtherCAT <sup>®</sup> system diagnostics
EtherCAT <sup>®</sup> hardware watchdog		
Emergency messages		Errors are indicated to the master
Diagnostic objects in the CoE object dictionary		Advanced diagnostics, e.g., of I/O errors
	F100	Local bus diag info
	F101	Local bus diag counters
	F103	Remaining system active
	F802	Validate module ident list
Diagnosis history object		16 diagnostic messages could not be stored
	10F3	Diagnosis history
Diagnostic status register		Local bus diagnostics in the input process data

## 16.2 EtherCAT® state machine

An error is indicated as follows:

- Error bit in the “AL status code” register is set.
- An error code is written in the “AL status code” register by the slave.

The following codes are implemented on the bus coupler:

AL status code (hex)	Meaning
0000	No error: There is no error.
0011	Invalid requested state change: The state change requested is invalid.
0012	Unknown requested state: The state requested does not exist.
0016	Invalid mailbox configuration: Error when configuring the SyncManager for mailbox communication.
001B	SyncManager watchdog: The hardware watchdog which monitors the SyncManager process data has expired.
001D	Invalid output configuration: Error in the SyncManager configuration for output process data.
001E	Invalid input configuration: Error in the SyncManager configuration for input process data.
0024	Invalid input mapping: The parameterized PDO mapping for the input process data is faulty (e.g., process data that is not available was included in the mapping).
0025	Invalid output mapping: The parameterized PDO mapping for the output process data is faulty (e.g., process data that is not available was included in the mapping).
0026	Inconsistent settings: The inconsistent settings parameterized by the master lead to a fault during the status transition (e.g., checking the module lists downloaded by the master fails).
0028	SyncMode not supported: The master attempts to set an operating mode that is not supported (SM synchronous, DC synchronous)
0029	FreeRun needs 3Buffer mode: One or both process data SyncManagers were configured in the 1Buffer mode. This is not permitted in the FreeRun operating mode.

### 16.3 Emergency messages

Emergency messages are an unverified service based on CoE. As such, all errors can be indicated to the master by the slave, taking the form of messages which are specified in ETG.1000.6.

- “Emergency messages” can be switched off via the CoE object 10F3<sub>hex</sub>.
- Only incoming faults are reported in “Emergency messages”.
- Unused data bytes are filled with 00<sub>hex</sub>.

The faults which could occur in the Inline system are separated into two groups with different message designs.

Detail of Inline bus and I/O errors on a CoE emergency message:

CoE emergency message	2 bytes	1 byte	5 bytes			
	Error code	Error reg	Data			
Peripheral fault	2 bytes	1 byte	2 bytes	1 byte	1 byte	1 byte
	Error code	80 <sub>hex</sub>	Error location	0	0	0

#### Peripheral fault

For the error codes for I/O errors, please refer to the data sheets for the I/O modules.

#### Local bus failure

For the error codes for local bus errors, please refer to the table.

The error code is displayed in the Emergency Message data area.

Error code (hex)	Meaning	Data
<b>Local bus failure</b>		
B000	Generic fault	
B001	No module present	Error location
B002	Wrong module present	Error location
B004	More modules present than expected	Error location
B012	Application on the module not ready	Error location
B013	Module reset	Error location
B021	Time-out	Error location
B022	Multiple transmission errors	Error location
B023	I/O data communication error	Error location
B024	Management data communication error	Error location
B025	Bus error on the module	Error location
B030	Configuration errors	
B041	Hardware fault	
B042	Firmware error	
F001	Inline I/O error	Error location
<b>Local module errors and warnings</b>		
6010	Device watchdog	
3221	U <sub>M</sub> supply voltage faulty	
3223	U <sub>S</sub> supply voltage faulty	
3225	U <sub>L</sub> supply voltage faulty	
F010	Checking the module list downloaded by the master failed	First faulty position in the list

**CoE emergency message**

<b>Error code (hex)</b>	<b>Meaning</b>
00xx	Error reset or no error
10xx	Generic error
20xx	Current
21xx	Current, device input side
22xx	Current inside the device
23xx	Current, device output side
30xx	Voltage
31xx	Mains voltage
32xx	Voltage inside the device
33xx	Output voltage
40xx	Temperature
41xx	Ambient temperature
42xx	Device temperature
50xx	Device hardware
60xx	Device software
61xx	Internal software
62xx	User software
63xx	Data set
70xx	Additional modules
80xx	Monitoring
81xx	Communication
82xx	Protocol error
8210	PDO not processed due to length error
8220	PDO length exceeded
90xx	External error
A0xx	ESM transition error
F0xx	Additional functions
FFxx	Device specific

#### 16.4 Diagnosis history 10F3<sub>hex</sub>

The object 10F3<sub>hex</sub> is implemented as a ring memory in Overwrite mode. The last 16 diagnostic messages are always stored; older messages are deleted.

The error codes of the Inline bus and I/O errors are stored in the object's diagnostic messages.

The following table shows the design of a diagnostic message from the Inline bus coupler for EtherCAT® as well as detailing specific Inline information.

Index (hex)	Subindex	Object name	Data type	Length	Rights	Meaning
10F3	00	Diagnosis history	Record			Diagnostic statistics
	01	Maximum messages	Unsigned 8	1	R	Maximum number of messages
	02	Newest message	Unsigned 8	1	R	Newest message
	03	Newest acknowledged message	Unsigned 8	1	R/W	Newest acknowledged message Writing a "0" deletes the message from the ring memory.
	04	New messages available	Boolean	0.1	R	New message present The information is also made available in the bus coupler input process data.
	05	Flags	Unsigned 16	2	R/W	Setting for the behavior of the object. See ETG.1020 and the following table.
	06 ... 21	Diagnosis message	Octet string	Variable	R	Diagnosis messages

Subindex 05 <sub>hex</sub> : flags		
Bit	Contents (hex)	Meaning
0	0	Switch off sending of "Emergency messages".
	1	Switch on sending of "Emergency messages".
1	0	Save diagnosis messages of type "Info".
	1	Do not save diagnosis messages of type "Info".
2	0	Save diagnosis messages of type "Warning".
	1	Do not save diagnosis messages of type "Warning".
3	0	Save diagnosis messages of type "Error".
	1	Do not save diagnosis messages of type "Error".
4 ... 15	0	Reserved

## 17 SafetyBridge

The bus coupler supports SafetyBridge V3.

Use a maximum of 16 safety modules in the Inline station.

## 18 Firmware update

It is possible to carry out a firmware update via EtherCAT®.

The File Access over EtherCAT® (FoE) mechanism is used for this, which is provided via your engineering system.

For detailed instructions for the firmware update with TwinCAT®, please refer to application note AH EN FIRMWARE UPDATE AXL F BK EC / IL EC BK-PAC.

The application note can be downloaded at [phoenixcontact.net/products](http://phoenixcontact.net/products).



# SCATTERGOOD & JOHNSON LTD

ELECTRICAL ENGINEERING & FLUID CONTROL DISTRIBUTORS

Est.1899

At Scattergood & Johnson Ltd, we pride ourselves on being a technical distributor to specialist industries.

Working with a range of quality product suppliers across a number of specialist markets, we are not your average 'box shifter' - we are your technical and supply chain partner.

We fully support every product we sell - for free! Our internal team and external sales engineers can answer any product or application question, no matter the complexity.

Backing up this technical ability is a range of 50,000+ products available from stock for nationwide next day delivery (same day if required!), or you can collect what you need from any of our trade counters around the UK.

Select your specialist interest below to learn more about how we can help.

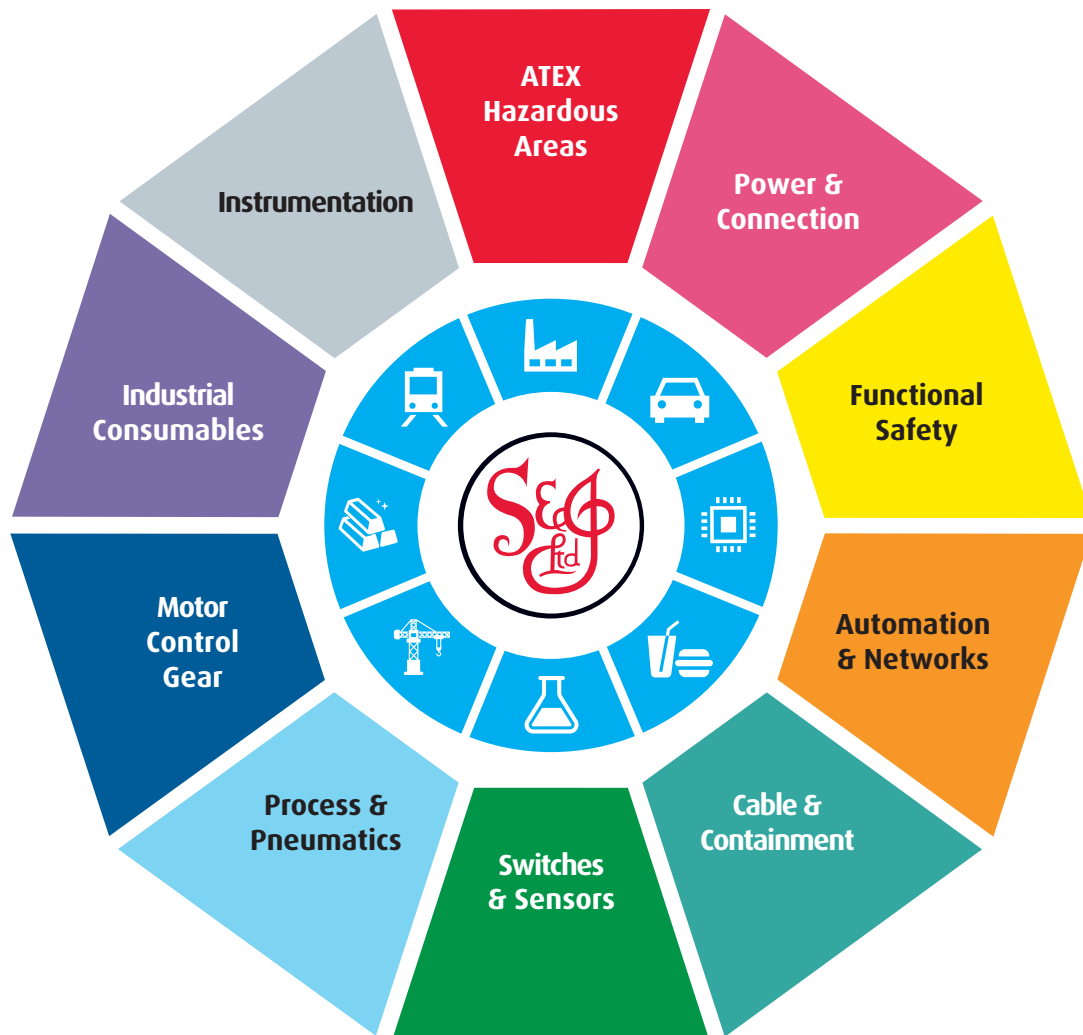

Online, In Branch and On the Road - Scattergood & Johnson Ltd, there when you need us.

# [www.scatts.co.uk](http://www.scatts.co.uk)