

IB IL 24 DO 8/HD-ECO

**Inline ECO, digital output terminal,
digital outputs: 8, 24 V DC, 500 mA**

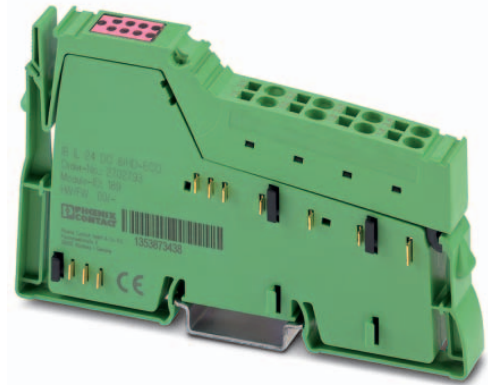

Data sheet
107135_en_00

© PHOENIX CONTACT 2016-11-03

1 Description

The terminal is designed for use within an Inline station. It is used to output digital signals. Inline ECO terminals are approved for the temperature range from 0°C to +55°C. The electronics base and Inline connector are supplied as standard.

Features

- 8 digital outputs
- Connection of actuators in single-wire technology
- Nominal current per output: 500 mA
- Total current of the terminal: 4 A
- Short-circuit-proof and overload-protected outputs
- Diagnostic and status indicators



This data sheet is only valid in association with the IL SYS INST UM E user manual.



Make sure you always use the latest documentation. It can be downloaded from the product at phoenixcontact.net/products.

2	Table of contents	
1	Description	1
2	Table of contents	2
3	Ordering data	3
4	Technical data	3
5	Internal circuit diagram	7
6	Terminal point assignment.....	7
7	Connection notes and examples	8
8	Local diagnostic and status indicators	9
9	Process data.....	9

3 Ordering data

Description	Type	Order No.	Pcs./Pkt.
Inline ECO, Digital output terminal, Digital outputs: 8, 24 V DC, 500 mA, Connection method: 1-wire, Transmission speed in the local bus 500 kBit/s, Degree of protection IP20, including Inline connector	IB IL 24 DO 8/HD-ECO	2702793	1
Accessories	Type	Order No.	Pcs./Pkt.
Connector, for digital 1, 2 or 8-channel Inline terminals (Connector/Adapter)	IB IL SCN-8	2726337	10
Labeling field, width: 12.2 mm (Marking)	IB IL FIELD 2	2727501	10
Inline terminal for power distribution (GND), complete with accessories, (connector and labeling field) connections for GND	IB IL PD GND-PAC	2862990	1
VARIOFACE front adapter for Inline HD modules, for transferring 8 digital signals. (Connector/Adapter)	FLKM 14-PA-INLINE/DIO8	2900889	1
Documentation	Type	Order No.	Pcs./Pkt.
User manual, English, Automation terminals of the Inline product range	IL SYS INST UM E	-	-
Data sheet, English, INTERBUS addressing	DB GB IBS SYS ADDRESS	-	-

4 Technical data

Dimensions (nominal sizes in mm)

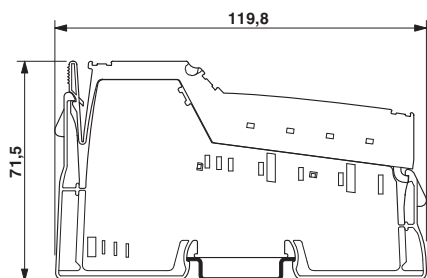

Width	12.2 mm
Height	119.8 mm
Depth	71.5 mm
General data	
Color	green
Weight	60 g (with connector)
Operating mode	Process data mode with one byte
Ambient temperature (operation)	0 °C ... 55 °C

General data

Ambient temperature (storage/transport)	-25 °C ... 85 °C
Permissible humidity (operation)	10 % ... 95 % (according to DIN EN 61131-2)
Permissible humidity (storage/transport)	10 % ... 95 % (according to DIN EN 61131-2)
Air pressure (operation)	70 kPa ... 106 kPa (up to 3000 m above sea level)
Air pressure (storage/transport)	70 kPa ... 106 kPa (up to 3000 m above sea level)
Degree of protection	IP20
Protection class	III, IEC 61140, EN 61140, VDE 0140-1

Connection data

Designation	Inline connector
Connection method	Spring-cage connection
Conductor cross section solid / stranded	0.08 mm ² ... 1.5 mm ² / 0.08 mm ² ... 1.5 mm ²
Conductor cross section [AWG]	28 ... 16
Stripping length	8 mm

Interface Inline local bus

Connection method	Inline data jumper
Transmission speed	500 kbps

Power consumption

Segment circuit supply U_S	24 V DC (nominal value)
Current consumption from U_S	max. 4 A DC
Communications power U_L	7.5 V DC
Current consumption from U_L	max. 45 mA
Power consumption	max. 0.62 W (at U_L)

Digital outputs

Number of outputs	8
Connection method	Spring-cage connection
Connection method	1-wire
Nominal output voltage	24 V DC
Voltage difference with nominal current	≤ 1 V
Maximum output current per channel	500 mA
Maximum output current per device	4 A
Nominal load, ohmic	12 W (48 Ω)
Nominal load, inductive	12 VA (1.2 H, 50 Ω)
Nominal load, lamp	12 W
Signal delay when switching on an ohmic nominal load	typ. 500 μs
Signal delay when switching on an inductive nominal load	typ. 500 μs (1.2 H, 50 Ω)
Signal delay when switching on a lamp nominal load	typ. 100 ms
Signal delay when switching off an ohmic nominal load	typ. 1 ms
Signal delay when switching off an inductive nominal load	typ. 50 ms (1.2 H, 50 Ω)
Signal delay when switching off a lamp nominal load	typ. 1 ms

Digital outputs

Maximum operating frequency with ohmic nominal load	max. 300 Hz (this switching frequency is limited by the number of bus devices, the structure of the bus, the software used and the control or computer system used)
Maximum operating frequency with inductive nominal load	max. 0.5 Hz (1.2 H, 50 Ω)
Maximum operating frequency with lamp nominal load	max. 8 Hz (this switching frequency is limited by the number of bus devices, the structure of the bus, the software used and the control or computer system used)
Reaction time with short-circuit	ca. 1 s
Reaction time with ohmic overload	ca. 3 s
Behavior at voltage switch-off	The output follows the power supply without delay
One-time unsolicited energy	300 mJ
Limitation of the voltage induced on circuit interruption	-45.8 V ... -15 V
Output voltage when switched off	max. 1 V
Output current when switched off	max. 300 μ A
Behavior with overload	Auto restart
Behavior with inductive overload	Output can be destroyed
Restart frequency with ohmic overload	400 Hz
Restart frequency with lamp overload	400 Hz
Reverse voltage resistance to short pulses	Reverse voltage proof
Resistance to permanent reverse voltage	max. 500 mA
Overcurrent shut-down	min. 0.7 A
Overload protection, short-circuit protection of outputs	Zener diode in output chip

Programming data (INTERBUS, local bus)

ID code (hex)	BD
ID code (dec.)	189
Length code (hex)	81
Length code (dec.)	129
Process data channel	8 Bit
Input address area	0 Byte
Output address area	1 Byte
Parameter channel (PCP)	0 Bit
Register length (bus)	8 Bit



For the programming data/configuration data of other bus systems, please refer to the corresponding electronic device data sheet (e.g., GSD, EDS).

Configuration and parameter data in a PROFIBUS system

Required parameter data	3 Byte
Need for configuration data	4 Byte

Error messages to the higher level control or computer system

Short-circuit / overload of the digital outputs	Error message in the diagnostic code (bus) and display (2 Hz) via the LED (D) on the module
---	---

Protective circuit

Short-circuit protection, overload protection in the segment circuit Electronic, for each module

Electrical isolation/isolation of the voltage areas**Test section****Test voltage**

7.5 V supply (bus logics)/24 V supply (I/O) 500 V AC, 50 Hz, 1 min.

7.5 V supply (bus logics) / functional earth ground 500 V AC, 50 Hz, 1 min.

24 V supply (I/O) / functional earth ground 500 V AC, 50 Hz, 1 min.



To achieve electrical isolation between the logic level and the I/O area, supply these areas from separate power supply units. Interconnection of the power supply units in the 24 V area is not permitted (see IL SYS INST UM E user manual).

Approvals

For the latest approvals, please visit phoenixcontact.net/products.

5 Internal circuit diagram

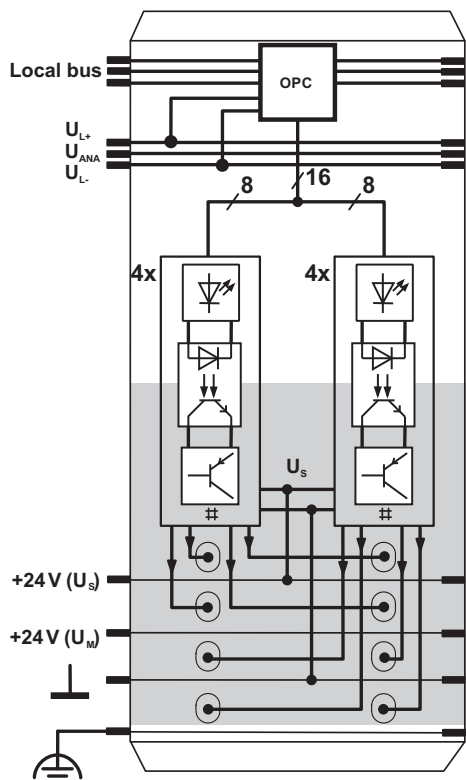









Figure 1 Internal wiring of the terminal points

Key:

-  Protocol chip
(Bus logic including voltage conditioning)
-  LED (status indicator)
-  Optocoupler
-  Transistor
-  Digital output
-  Electrically isolated area

 Explanation for other used symbols has been provided in the IL SYS INST UM E user manual.

6 Terminal point assignment

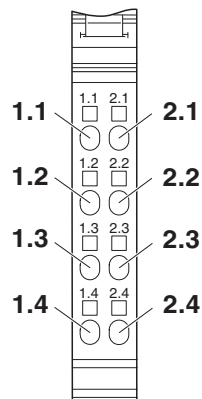

Figure 2 Terminal point assignment

Terminal point	Assignment
1.1 / 2.1	Signal output (OUT01 / OUT02)
1.2 / 2.2	Signal output (OUT03 / OUT04)
1.3 / 2.3	Signal output (OUT05 / OUT06)
1.4 / 2.4	Signal output (OUT07 / OUT08)

7 Connection notes and examples

i When connecting the actuators, observe the assignment of the terminal points to the process data.

! **NOTE: Malfunction**
 GND of the actuators and GND of the supply voltage U_S , which supply the actuators, must have the same potential.

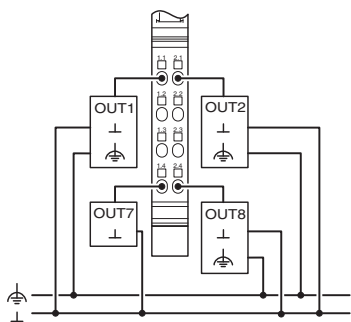

Figure 3 Typical connection of actuators when using external busbars

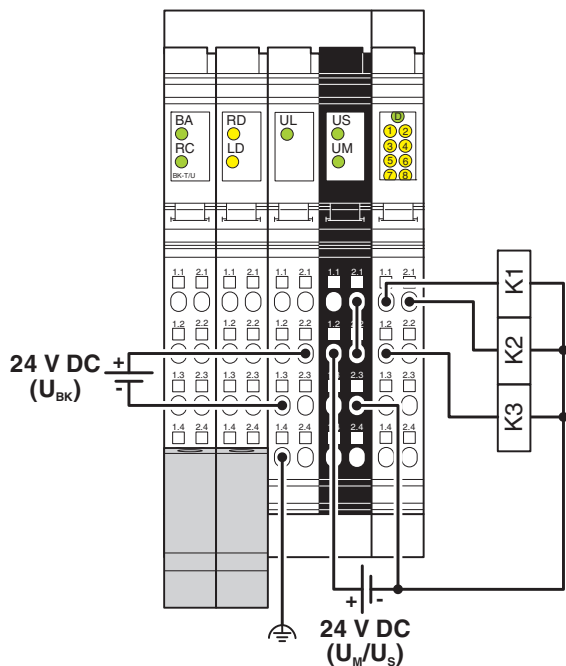

Figure 4 Connection of contactors when using external busbars

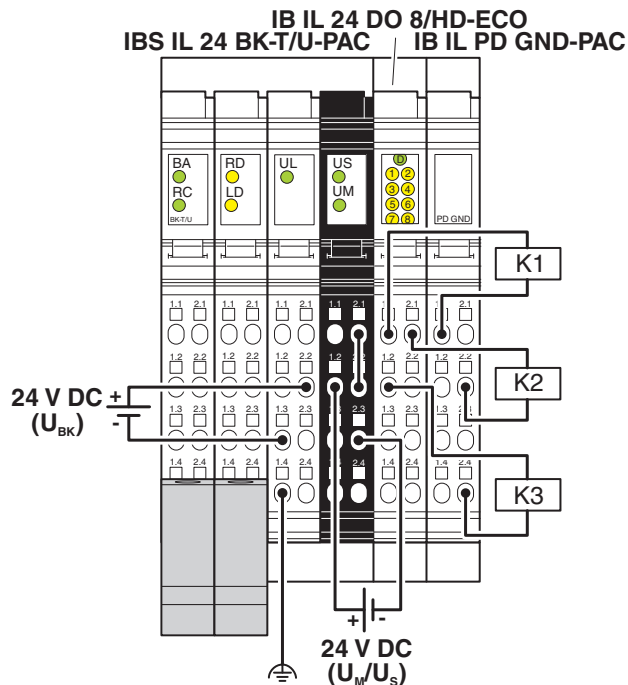

Figure 5 Connection of contactors when using the IB IL PD GND-PAC terminal

8 Local diagnostic and status indicators

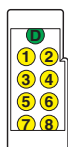

Figure 6 Local diagnostic and status indicators

Designation	Color	Meaning
D	Green	Diagnostics (bus and logic voltage)
1 ... 8	Yellow	Status of the outputs

Function identification

Pink

9 Process data

Assignment of the terminal points to the output process data

(Byte.Bit) view	Byte	Byte 0							
	Bit	7	6	5	4	3	2	1	0
Assignment	Signal	OUT08	OUT07	OUT06	OUT05	OUT04	OUT03	OUT02	OUT01
	Terminal point (signal)	2.4	1.4	2.3	1.3	2.2	1.2	2.1	1.1
Status indicator	LED	8	7	6	5	4	3	2	1



For the assignment of the illustrated (byte.bit) view to your INTERBUS control or computer system, please refer to the DB GB IBS SYS ADDRESS data sheet.



SCATTERGOOD & JOHNSON LTD

ELECTRICAL ENGINEERING & FLUID CONTROL DISTRIBUTORS

Est.1899

At Scattergood & Johnson Ltd, we pride ourselves on being a technical distributor to specialist industries.

Working with a range of quality product suppliers across a number of specialist markets, we are not your average 'box shifter' - we are your technical and supply chain partner.

We fully support every product we sell - for free! Our internal team and external sales engineers can answer any product or application question, no matter the complexity.

Backing up this technical ability is a range of 50,000+ products available from stock for nationwide next day delivery (same day if required!), or you can collect what you need from any of our trade counters around the UK.

Select your specialist interest below to learn more about how we can help.



Online, In Branch and On the Road - Scattergood & Johnson Ltd, there when you need us.

www.scatts.co.uk