

# IB IL 24 DO 4/EF-ECO

**Inline ECO, digital output terminal,  
digital outputs: 4, 24 V DC, 500 mA**

Data sheet  
107450\_en\_00

© PHOENIX CONTACT 2016-11-25

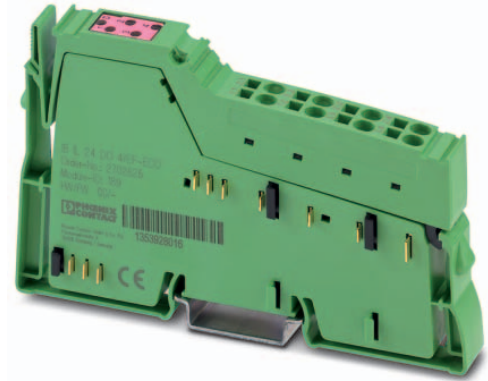

## 1 Description

The terminal is designed for use within an Inline station. It is used to output digital signals. Inline ECO terminals are approved for the temperature range from 0°C to +55°C. The electronics base and Inline connector are supplied as standard.

### Features

- 4 digital outputs
- Connection of actuators in 2 and 3-wire technology
- Nominal current per output: 500 mA
- Total current of the terminal: 2 A
- Short-circuit-proof and overload-protected outputs
- Diagnostic and status indicators
- Approved for use in a safety-related segment circuit.



This data sheet is only valid in association with the IL SYS INST UM E user manual.



Make sure you always use the latest documentation. It can be downloaded from the product at [phoenixcontact.net/products](http://phoenixcontact.net/products).



When using the terminal in a safety-related segment circuit, pay attention to the corresponding notes!

---

<b>2</b>	<b>Table of contents</b>	
1	Description .....	1
2	Table of contents .....	2
3	Ordering data .....	3
4	Technical data .....	3
5	Additional tables .....	7
	5.1 Output characteristic curve.....	7
	5.2 Power dissipation .....	7
	5.3 Limitation of simultaneity, derating .....	7
6	Internal circuit diagram .....	8
7	Terminal point assignment.....	8
8	Connection notes and examples .....	9
9	Notes on using the terminal in a safety-related segment circuit .....	9
10	Local diagnostic and status indicators .....	9
11	Process data.....	9

### 3 Ordering data

Description	Type	Order No.	Pcs./Pkt.
Inline ECO, Digital output terminal, Digital outputs: 4, 24 V DC, 500 mA, Connection method: 3-conductor, Transmission speed in the local bus 500 kbps, Degree of protection IP20, including Inline connector	IB IL 24 DO 4/EF-ECO	2702825	1
Accessories	Type	Order No.	Pcs./Pkt.
Connector, for digital 1, 2 or 8-channel Inline terminals (Connector/Adapter)	IB IL SCN-8	2726337	10
Labeling field, width: 12.2 mm (Marking)	IB IL FIELD 2	2727501	10
Documentation	Type	Order No.	Pcs./Pkt.
User manual, English, Automation terminals of the Inline product range	IL SYS INST UM E	-	-
Data sheet, English, INTERBUS addressing	DB GB IBS SYS ADDRESS	-	-
Application note, English, The safety-related segment circuit	AH EN IL SAFE	-	-

### 4 Technical data

#### Dimensions (nominal sizes in mm)

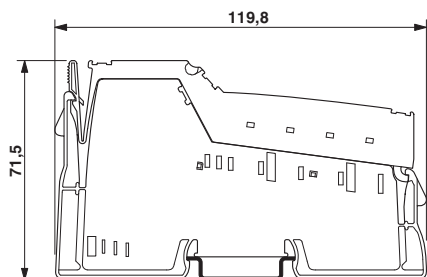

Width	12.2 mm
Height	119.8 mm
Depth	71.5 mm

#### General data

Color	green
Weight	60 g (with connector)
Operating mode	Process data operation with 4 bits
Ambient temperature (operation)	0 °C ... 55 °C
Ambient temperature (storage/transport)	-25 °C ... 85 °C
Permissible humidity (operation)	10 % ... 95 % (according to DIN EN 61131-2)

<b>General data</b>	
Permissible humidity (storage/transport)	10 % ... 95 % (according to DIN EN 61131-2)
Air pressure (operation)	70 kPa ... 106 kPa (up to 3000 m above sea level)
Air pressure (storage/transport)	70 kPa ... 106 kPa (up to 3000 m above sea level)
Degree of protection	IP20
Protection class	III, IEC 61140, EN 61140, VDE 0140-1
<b>Connection data</b>	
Designation	Inline connector
Connection method	Spring-cage connection
Conductor cross section solid / stranded	0.08 mm <sup>2</sup> ... 1.5 mm <sup>2</sup> / 0.08 mm <sup>2</sup> ... 1.5 mm <sup>2</sup>
Conductor cross section [AWG]	28 ... 16
Stripping length	8 mm
<b>Interface Inline local bus</b>	
Connection method	Inline data jumper
Transmission speed	500 kbps
<b>Power consumption</b>	
Segment circuit supply U <sub>S</sub>	24 V DC (nominal value)
Current consumption from U <sub>S</sub>	max. 2 A
Communications power U <sub>L</sub>	7.5 V DC
Current consumption from U <sub>L</sub>	max. 44 mA
Power consumption	max. 0.33 W (at U <sub>L</sub> )
<b>Digital outputs</b>	
Number of outputs	4
Connection method	Spring-cage connection
Connection method	3-conductor
Nominal output voltage	24 V DC
Voltage difference with nominal current	≤ 1 V
Maximum output current per channel	500 mA
Maximum output current per device	2 A
Nominal load, ohmic	12 W (48 Ω)
Nominal load, inductive	12 VA (1.2 H, 50 Ω)
Nominal load, lamp	12 W
Signal delay when switching on an ohmic nominal load	typ. 100 μs
Signal delay when switching on an inductive nominal load	typ. 100 ms (1.2 H, 50 Ω)
Signal delay when switching on a lamp nominal load	typ. 100 ms (for switching frequencies up to 8 Hz, above this frequency, the lamp load behaves like an ohmic load)
Signal delay when switching off an ohmic nominal load	typ. 1 ms
Signal delay when switching off an inductive nominal load	typ. 50 ms (1.2 H, 50 Ω)
Signal delay when switching off a lamp nominal load	typ. 1 ms

**Digital outputs**

Maximum operating frequency with ohmic nominal load	max. 300 Hz (this switching frequency is limited by the number of bus devices, the structure of the bus, the software used and the control or computer system used)
Maximum operating frequency with inductive nominal load	max. 0.5 Hz (1.2 H, 50 $\Omega$ )
Maximum operating frequency with lamp nominal load	max. 300 Hz (this switching frequency is limited by the number of bus devices, the structure of the bus, the software used and the control or computer system used)
Reaction time with short-circuit	ca. 850 ms
Reaction time with ohmic overload	ca. 3 s
Behavior at voltage switch-off	The output follows the power supply without delay
Output data validity	typ. 5 ms (after switching the 24 V voltage supply (power up))
One-time unsolicited energy	400 mJ
Limitation of the voltage induced on circuit interruption	-46 V ... -15 V
Output voltage when switched off	max. 2 V
Output current when switched off	max. 300 $\mu$ A
Behavior with overload	Auto restart
Behavior with inductive overload	Output can be destroyed
Restart frequency with ohmic overload	250 Hz
Restart frequency with lamp overload	250 Hz
Reverse voltage resistance to short pulses	Reverse voltage proof
Resistance to permanent reverse voltage	to 2 A DC
Resistance to permanently applied surge voltage	No
Overcurrent shut-down	min. 0.7 A
Output current with ground connection interrupt when switched off	max. 25 mA
Switching capacity	typ. 100 mW (in the case of ground connection interrupt, at 1 k $\Omega$ load resistance)
Inrush current	max. 1.5 A (for 20 ms)
Overload protection, short-circuit protection of outputs	Zener diode in output chip The four channels are thermally coupled, i.e. an error in one channel can also influence the other channels.

**Programming data (INTERBUS, local bus)**

ID code (hex)	BD
ID code (dec.)	189
Length code (hex)	41
Length code (dec.)	65
Process data channel	4 Bit
Input address area	0 Byte
Output address area	4 Bit

**Programming data (INTERBUS, local bus)**

Parameter channel (PCP)	0 Bit
Register length (bus)	4 Bit



For the programming data/configuration data of other bus systems, please refer to the corresponding electronic device data sheet (e.g., GSD, EDS).

**Configuration and parameter data in a PROFIBUS system**

Required parameter data	3 Byte
Need for configuration data	4 Byte

**Error messages to the higher level control or computer system**

Short-circuit / overload of the digital outputs	Error message in the diagnostic code (bus) and display (2 Hz) via the LED (D) on the module
---	---

**Protective circuit**

Short-circuit protection, overload protection in the segment circuit	Electronic, for each module
--	-----------------------------

**Electrical isolation/isolation of the voltage areas**

Test section	Test voltage
5 V supply, incoming remote bus/7.5 V supply (bus logics)	500 V AC, 50 Hz, 1 min.
5 V supply, outgoing remote bus/7.5 V supply (bus logics)	500 V AC, 50 Hz, 1 min.
7.5 V supply (bus logics)/24 V supply (I/O)	500 V AC, 50 Hz, 1 min.
24 V supply (I/O) / functional earth ground	500 V AC, 50 Hz, 1 min.



To achieve electrical isolation between the logic level and the I/O area, supply these areas from separate power supply units. Interconnection of the power supply units in the 24 V area is not permitted (see IL SYS INST UM E user manual).

**Approvals**

For the latest approvals, please visit [phoenixcontact.net/products](http://phoenixcontact.net/products).

## 5 Additional tables

### 5.1 Output characteristic curve

Output characteristic curve when switched on (typical)	
Output current (A)	Differential output voltage (V)
0	0
0.1	0.04
0.2	0.08
0.3	0.12
0.4	0,16
0.5	0,20

### 5.2 Power dissipation

**Formula for calculating the power dissipation of the electronics**

$$P_{EL} = 0,19 \text{ W} + \sum_{i=1}^n (0,10 \text{ W} + I_{Li}^2 \times 0,40 \Omega)$$

Where:

$P_{EL}$	Total power dissipation in the terminal
$i$	Continuous index
$n$	Number of outputs set ( $n = 1 \dots 4$ )
$I_{Li}$	Load current of output $i$

### Power dissipation of the housing

Maximum 0.6 W (within the permissible operating temperature)

### 5.3 Limitation of simultaneity, derating

Ambient temperature $T_{amb}$	Maximum load current		
	100 % simultaneity	75 % simultaneity	50 % simultaneity
$\leq 35 \text{ }^\circ\text{C}$	0.5 A	0.5 A	0.5 A
$\leq 45 \text{ }^\circ\text{C}$	0.375 A	0.5 A	0.5 A
$\leq 55 \text{ }^\circ\text{C}$	0.25 A	0.33 A	0.5 A

At 100 % simultaneity, a load current of 0.5 A per channel is permissible within the ambient temperature range up to 35 °C, a load current of 0.375 A in the range from 35 °C to 45 °C and a load current of 0.25 A in the range from 45 °C to 55 °C.

If a maximum of two channels are operated in the overall permissible ambient temperature range (50% simultaneity), a load current of 0.5 A may be tapped.

If all channels are used, the permissible working point must be defined according to the above-stated formula.



An example for calculating the working point can be found in the user manual IL SYS INST UM E.

### 6 Internal circuit diagram

### 7 Terminal point assignment

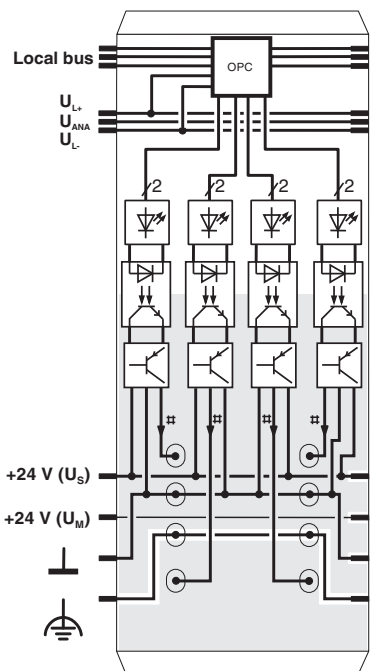









Figure 1 Internal wiring of the terminal points

Key:

-  Protocol chip  
(Bus logic including voltage conditioning)
-  LED (status indicator)
-  Optocoupler
-  Transistor
-  Digital output
-  Electrically isolated area

 Explanation for other used symbols has been provided in the IL SYS INST UM E user manual.

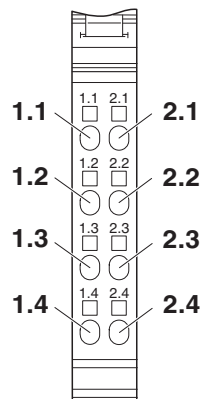

Figure 2 Terminal point assignment

Terminal point	Assignment
1.1 / 2.1	Signal output (OUT01 / OUT02)
1.2 / 2.2	Ground contact (GND) for 2 and 3-wire connection
1.3 / 2.3	FE connection for 3-wire connection
1.4 / 2.4	Signal output (OUT03 / OUT04)

## 8 Connection notes and examples



When connecting the actuators, observe the assignment of the terminal points to the process data.



### WARNING: Loss of electrical and functional safety

When using the terminal in a safety-related segment circuit, observe the following:

The actuators that are connected to this terminal must be fully wired to this terminal.

An external ground or functional earth ground must not be used.

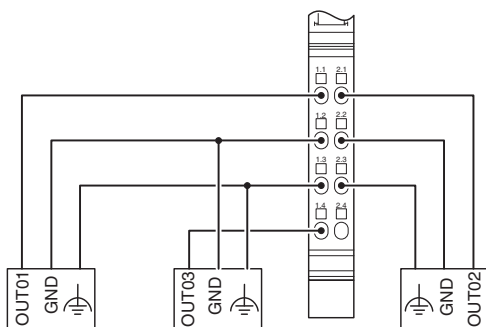

Figure 3 Typical connection of actuators

## 9 Notes on using the terminal in a safety-related segment circuit

As of hardware revision 00, the terminal is approved for use in a safety-related segment circuit.



The hardware revision is marked on the side of the housing of each terminal.



When using the terminal in a safety-related segment circuit, also observe the requirements in the documentation of the safety terminal as well as in the AH DE IL SAFE / AH EN IL SAFE application notes!

The documentation can be found on the Internet at [phoenixcontact.net/products](http://phoenixcontact.net/products).

## 10 Local diagnostic and status indicators

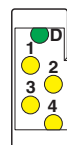

Figure 4 Local diagnostic and status indicators

Designation	Color	Meaning
D	Green	Diagnostics (bus and logic voltage)
1 ... 4	Yellow	Status of the outputs

### Function identification

Pink

## 11 Process data

### Assignment of the terminal points to the output process data

(Byte.Bit) view	Byte.Bit	0.3	0.2	0.1	0.0
Assignment	Signal	OUT04	OUT03	OUT02	OUT01
	Terminal point (signal)	2.4	1.4	2.1	1.1
	Terminal point (GND)	2.2	1.2	2.2	1.2
	Terminal point (FE)	2.3	1.3	2.3	1.3
Status indicator	LED	4	3	2	1



For the assignment of the illustrated (byte.bit) view to your INTERBUS control or computer system, please refer to the DB GB IBS SYS ADDRESS data sheet.



# SCATTERGOOD & JOHNSON LTD

ELECTRICAL ENGINEERING & FLUID CONTROL DISTRIBUTORS

Est.1899

At Scattergood & Johnson Ltd, we pride ourselves on being a technical distributor to specialist industries.

Working with a range of quality product suppliers across a number of specialist markets, we are not your average 'box shifter' - we are your technical and supply chain partner.

We fully support every product we sell - for free! Our internal team and external sales engineers can answer any product or application question, no matter the complexity.

Backing up this technical ability is a range of 50,000+ products available from stock for nationwide next day delivery (same day if required!), or you can collect what you need from any of our trade counters around the UK.

Select your specialist interest below to learn more about how we can help.



Online, In Branch and On the Road - Scattergood & Johnson Ltd, there when you need us.

# [www.scatts.co.uk](http://www.scatts.co.uk)