

Inline DeviceNet™ Bus Coupler IL DN BK3

Data Sheet 1435D

August 2005

1. Description

The Inline DeviceNet™ bus coupler (IL DN BK3) allows for communications between the Phoenix Contact family of Inline I/O modules and a DeviceNet™ network. See Figure 1. The bus coupler is housed in a 91 mm (3.58 in.) wide package. Diagnostic indicators are provided for both the Inline local I/O and DeviceNet™ communications. The IL DN BK3 is UL/cUL recognized and has received the CE mark of approval. The IL DN BK3 has also been conformance tested and certified by the ODVA.

2. Inline Features

- Connects up to 63 I/O modules
- Advanced diagnostics
- Field installable with no software required for automatic station configuration
- Latching inputs
- Latched diagnostics
- Reservation of I/O memory for future expansion (No hardware needed)
- Types of Inline modules supported:
 - Digital input and output
 - Analog input and output
 - Intelligent function modules
 - Machine-mount Loop 2 I/O modules



WARNING

THIS EQUIPMENT IS SUITABLE FOR USE IN CLASS 1, DIVISION 2, GROUPS A, B, C, AND D OR NON-HAZARDOUS LOCATIONS ONLY.

WARNING – EXPLOSION HAZARD – SUBSTITUTION OF COMPONENTS MAY IMPAIR SUITABILITY FOR CLASS 1, DIVISION 2.

WARNING – EXPLOSION HAZARD – DO NOT DISCONNECT EQUIPMENT UNLESS POWER HAS BEEN SWITCHED OFF OR THE AREA IS KNOWN TO BE NON-HAZARDOUS.

3. DeviceNet™ Features

- I/O peer-to-peer Yes
- Explicit peer-to-peer messaging Yes
- Consistent configuration Yes
- Faulted node recovery Yes
- Baud rates:
 - 125K Yes
 - 250K Yes
 - 500K Yes
- I/O slave messaging:
 - Polled Yes
 - Cyclic Yes
 - Change of state (COS) Yes
 - Bit Strobe Yes

- | | |
|--------------------------------|--|
| 1 Mounting Rail | 7* Labeling Field |
| 2 Grounding Terminal (USLKG 5) | 8 Grounding Wire 0.2 to 1.5 mm ² (24 to 16 AWG) |
| 3* End Clamp (CLIPFIX 35) | 9 Twin COMBICON DeviceNet™ Network Connector |
| 4 Bus Coupler | 10 Electronic Data Sheet (EDS) Disk |
| 5 End Plate | |
| 6* Power Connector | |

* Included with IL DN BK3-PAC

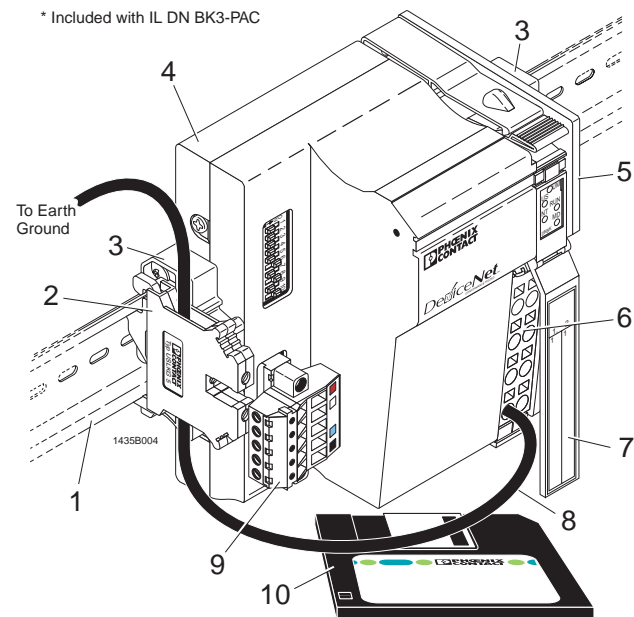

Figure 1. Inline DeviceNet™ Bus Coupler

DeviceNet™ is a trademark of Open DeviceNet Vendor Association, Inc.

4. Wiring the Bus Coupler

a. Bus Coupler Connector Numbering

Figure 2 shows the standard numbering scheme for wiring the bus coupler. Figure 2, View A shows connector numbering for the 2-row (5 contacts per row) network connector. View B shows connector numbering for the 2-row power connector.

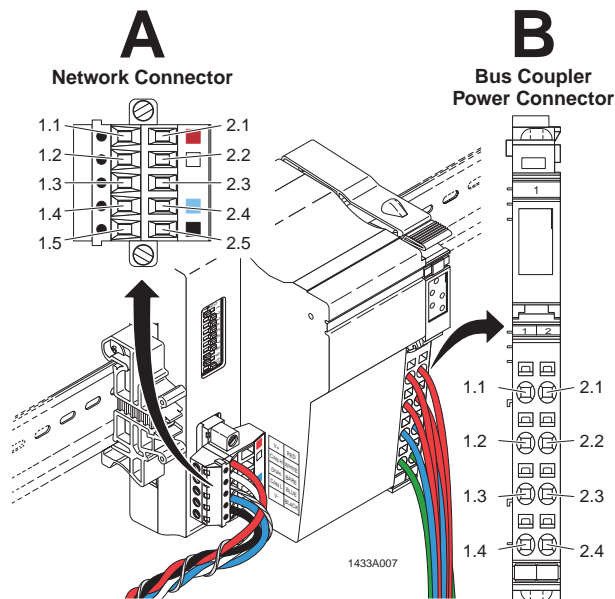

Figure 2. Bus Coupler Numbering and Terminal Assignments

b. Bus Coupler Terminal Assignments

Table 1 lists terminal assignments for the bus coupler connectors. Figure 3 shows a wiring schematic for the power connector that includes internal connections. Note that the bus coupler provides I/O power to the main (U_M) and segment (U_S) circuits for the Inline station. Logic power (communications) and analog power are supplied by the bus coupler through the U_L connection.

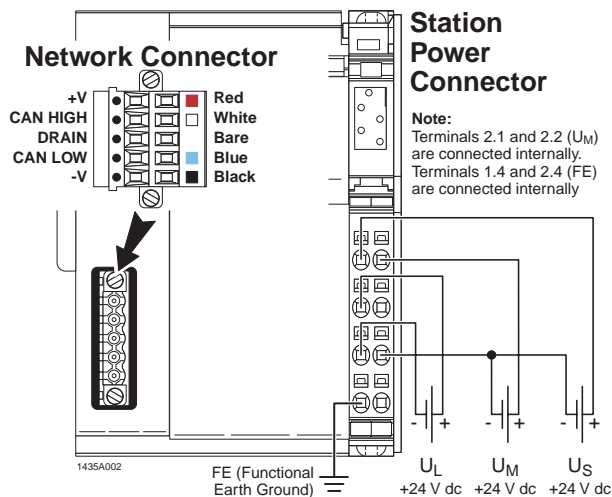

Figure 3. Bus Coupler Power Connections

Table 1. Bus Coupler Network and Power Connector Terminal Assignments

Network Connector	
Row & Terminal No.	Description
1.1 & 2.1	+V (+24 V), [red]
1.2 & 2.2	CAN H (white)
1.3 & 2.3	Drain (bare)
1.4 & 2.4	CAN L (blue)
1.5 & 2.5	-V (+24 V RTN), [black]
Power Connector	
Row & Terminal No.	Description
1.1	+24 V dc (Segment circuit U_S), [red]
1.2	+24 V dc (Logic circuit U_L), [red]
1.3	U_L GND (Logic ground), [blue]
1.4	FE (Functional Earth ground), [green]
2.1 & 2.2	+24 V dc (Main circuit U_M), [red]
2.3	GND (U_S and U_M), [blue]
2.4	FE (Functional Earth ground), [green]

1433A011

c. Bus Coupler Power Supplies



Observe the current carrying capacity. The maximum total current that can flow through U_S , U_M and common ground potential jumpers is 8 amps.

Ground the bus coupler to earth ground using one of the FE terminals (1.4 or 2.4) on the power connector. See Figure 3. Then using a piece of 1.5 to 0.2 mm² (16 to 24 AWG) wire, connect the FE terminal to a grounding terminal block. Refer to Figure 1, Item 2.

d. 24 V Segment Supply (U_S) and 24 V Main Supply (U_M)

Both the segment supply and the main supply have the same reference potential. Therefore, an isolated voltage area on the I/O side cannot be created without adding a power terminal.

Both the main supply and the segment supply are protected against polarity reversal and surge voltage.



The main supply and the segment supply do not have short circuit protection. The user must provide short circuit protection. The rating of the fuse must be such that the maximum permissible load current is not exceeded.

Segment voltage can be supplied at the bus coupler or a power terminal. There are several ways of providing the segment voltage to the bus coupler:

1. You can provide the segment voltage separately by using terminals 1.1 and 2.3 (GND) of the power connector. See Table 1.
2. You can jumper the connections 1.1 and 2.1 or 2.2 to ensure that the segment circuit is supplied from the main circuit.
3. With a switch between the terminal points 1.1 and 2.1 or 2.2 you can create a segment circuit (e.g. an emergency stop circuit).

e. 24 V Logic and Analog Supply (U_L)

U_L provides communications voltage and analog voltage to the connected Inline I/O modules. It is recommended that a separate supply is used.

The U_L supply has protection against polarity reversal and surge voltage. These elements will protect the power supply unit.

! CAUTION

The U_L supply does not have short-circuit protection.

The user must provide short circuit protection. The rating of the fuse must be such that the maximum permissible load current is not exceeded.

5. Networking Information

DeviceNet™ utilizes a linear bus topology. See Figure 4. Terminating resistors are required at each end of the trunk cable. Drop cables, made of trunk or drop cable, may be as long as 6 m (20 feet), and each drop can support one or more nodes. The total length of trunk and drop cable that can be used on the network depends upon the type of cable and/or the baud rate.

If network is based on data rate, see Table 2 to determine the maximum length of a network. See the DeviceNet™ specification for more details on network lengths vs. current draw.

a. Trunk Cable

The trunk cable is used to connect individual nodes and drop segments together to form a network. See Figure 4. Trunk cable is used when drop segments are not required. If drops are required, taps must be installed at the junction between the drop cable and the trunk cable. The maximum number of nodes on a DeviceNet™ network is 64.

b. Drop Cable

The drop cable is used to connect drop segment nodes to the trunk cable. See Figure 4. The drop cable connection is made by using a network tap. Drop cable is typically thinner and more flexible than trunk cable and is rated to carry less current.

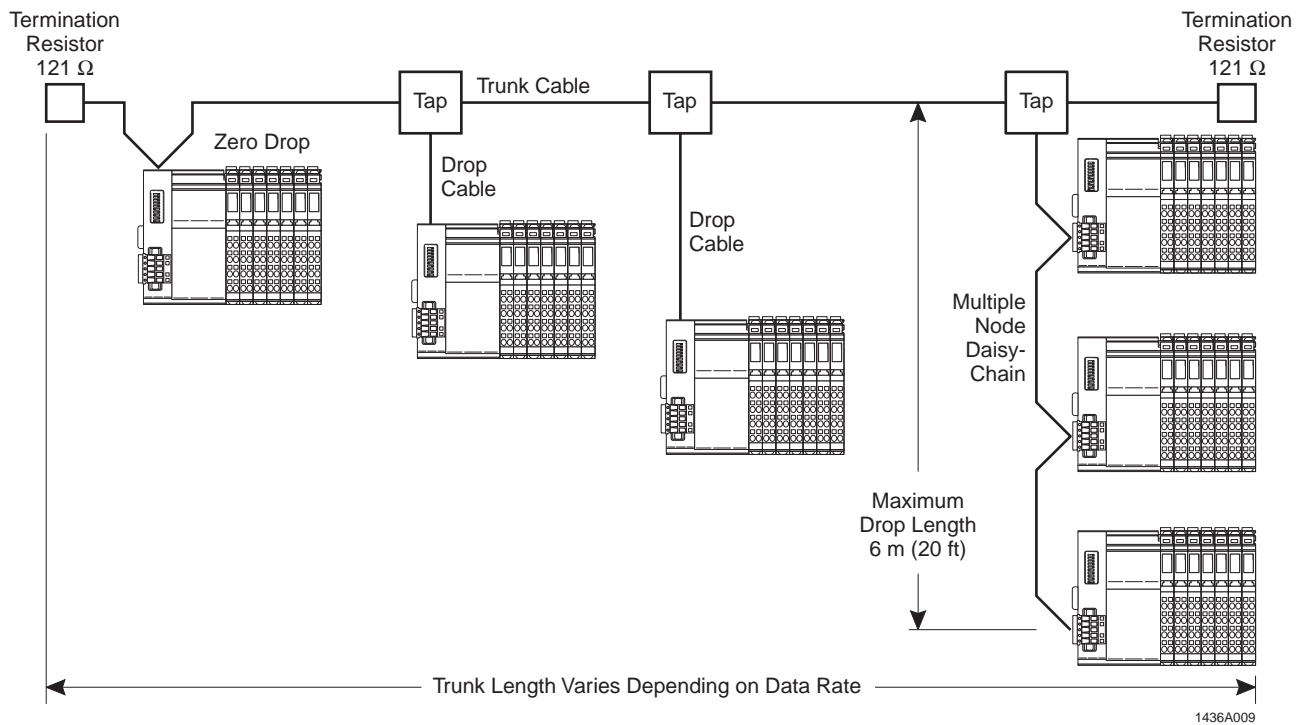

Figure 4. Example DeviceNet™ Topology

Table 2. Maximum Cable Length

Baud Rate	Baud Rate DIP-Switch Settings	Trunk Distance		Drop Length	
		Thick	Thin	Maximum	Cumulative
125k baud	8 OFF, 9 OFF	500 m (1640 ft)	100 m (328 ft)	6 m (20 ft)	156 m (512 ft)
250k baud	8 OFF, 9 ON	250 m (820 ft)	100 m (328 ft)	6 m (20 ft)	78 m (256 ft)
500k baud	8 ON, 9 OFF	100 m (328 ft)	100 m (328 ft)	6 m (20 ft)	39 m (128 ft)

1436A076

c. Termination Resistors

To reduce unwanted reflections and to ensure stable communications, termination resistors must be installed at the extreme ends of the main DeviceNet™ trunk, including drops. See Figure 4. For DeviceNet™ trunks with drops, the required termination resistor is a 121 ohms, 1% metal film with a power dissipation rating of 0.25 watts. Termination resistors are not supplied with the bus coupler.

6. DIP Switch Settings for Address and Baud Rate

Each bus coupler has 10 DIP switches. These switches are located on the left side of the bus coupler, see Figure 5. DIP switches 1 through 7 are used to set the node address and DIP switches 8 and 9 are used to set the baud rate. DIP switch 10 sets the bus coupler configuration mode as described in Figure 5.

a. Setting the Node Address

The node address (MAC ID) is set using DIP switches 1 through 7. DIP switch 7 is the least significant digit of the MAC ID and DIP switch 1 is the most significant digit. Valid MAC ID settings range from 0 to 63. Note that DeviceNet™ power must be cycled (OFF & ON) in order to implement any changes in a hardware selected node address (MAC ID).

b. Setting the Baud Rate

The baud rate is set using DIP switches 8 and 9. DIP-switch settings for various baud rates are shown in Figure 5. Note that DeviceNet™ power must be cycled in order to implement any changes to the baud rate.

c. Restoring Factory Default Settings

Set DIP switches 1 through 7 to the ON position. Then apply power to the bus coupler to restore all settings to factory default.

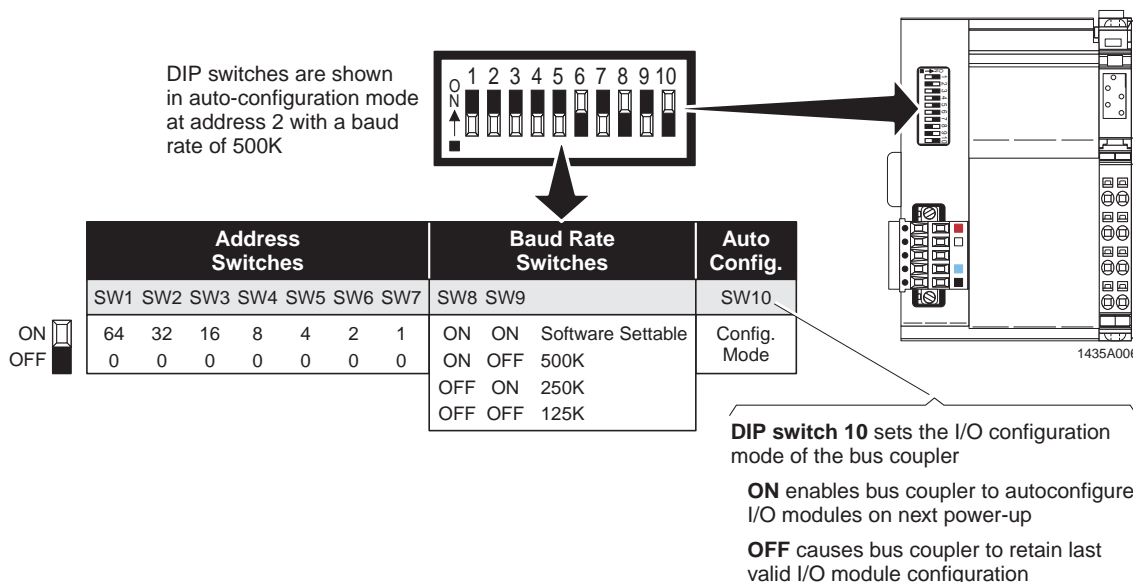

Figure 5. DIP Switch Meanings

7. Configuring the Bus Coupler Using the DIP Switches

Auto-configuration using the DIP switches allows for "in-the-field" configuration of the bus coupler without the use of any software. It will configure using the following default settings:

- Inline Status word added as the first two bytes in the produced response.
- All digital, analog and special function modules are added to produced response and/or consumed request.

a. Auto-configuration Procedure

To use the auto-configuration option, proceed as described in the following steps:

1. Set the node address and baud rate using DIP switches 1 through 9.
2. Set DIP switch 10 to the "ON" position.
3. Power up the bus coupler (DeviceNet™ and U_L power) with the required I/O connected. When the MD and RUN LEDs become solid green on the bus coupler, the station will have stored the I/O configuration in the flash memory.
4. Set DIP switch 10 to the "OFF" position. This will disable the auto-configuration feature on the next power-up and ensure that the present configuration is the same on the next power-up.

b. Understanding I/O Memory Mapping

An input memory map may contain the Inline Status word, which is included by default in the produced data. In addition to the Inline Status word, input data for digital input, analog input and special function modules may be included in the input memory map.

An output memory map may contain the control byte, which is not included by default. In addition to the control byte, output data for digital output, analog output and special function modules may be included in the input memory map.

I/O mapping order is determined by the type and position of a I/O module. Modules closest to the bus coupler will map first. All digital points are mapped before all analog channels and before special function modules, without regard to physical location on the Inline station. Analog channels are mapped before special function data words. Inline special function modules include the following module types:

- IB IL SSI — Absolute Encoder
- IB IL INC — Incremental Encoder
- IB IL CNT — High-speed Counter

- ASI MA IB IL — Inline to AS-i controller
- IB IL RS 232* — RS232 Module
- IB IL RS 485/422* — RS485/422 Module

Note

If any diagnostic status data is to be included in the produced-data, such as the Inline Status word, then that type of data would appear in the input image before any digital, analog or special function input data. If the command byte is to be included in the consumed data, then it would appear in the output image before any digital, analog or special function output data.

If the total number of digital points, of the same image, is not modulus 8, there will be unused bits between the digital data area and the analog (or special function) data area.

Note:

I/O modules that are connected to the bus coupler determine whether or not analog data starts on an even or odd byte. In those cases when analog or special function data starts on an odd byte, analog data could span two words in the master scanner. If you prefer to have analog data to start on an even byte, an optional I/O padding function "Pad I/O" can be enabled to ensure that analog and special function data starts on an even byte boundary. This option can be enabled by using the EDS file or by sending an explicit message.

c. Example I/O Table (Memory Map)

Figure 6 displays a memory map example for mixed input and output module configurations.

The total amount of input bytes (includes the Inline Status word) would be 11 and the total amount of output bytes would be 7. This example consist of the following I/O modules:

- 2-bit digital input (DI2)
- 1-channel analog output (AO1)
- 2-bit digital output (DO2)
- 4-bit digital input (DI4)
- 2-channel analog input (AI2)
- 4-bit digital output (DO4)
- 1 High-speed counter (CNT)

* Module is not supported in bus coupler firmware Version 1.01.

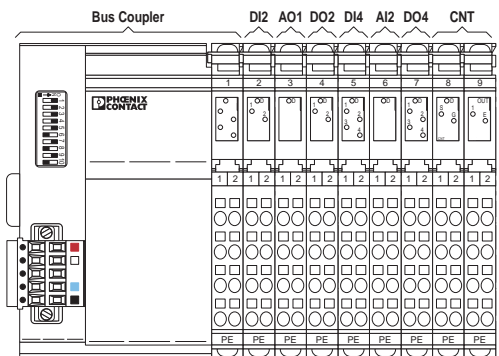

I/O Data Tables	
Input Data	Output Data
Byte 0 Bit 7 ← 0 Input Status Word, Low Byte	Bit 7 ← 0 Not Used Not Used DO-4 Bit 3 DO-4 Bit 2 DO-4 Bit 1 DO-4 Bit 0 DO-2 Bit 1 DO-2 Bit 0
Byte 1 Bit 15 ← 8 Input Status Word, High Byte	Bit 7 ← 0 Analog Output, Low Byte
Byte 2 Bit 7 ← 0 Not Used Not Used DI-4 Bit 3 DI-4 Bit 2 DI-4 Bit 1 DI-2 Bit 1 DI-2 Bit 0	Bit 15 ← 8 Analog Output, High Byte
Byte 3 Bit 7 ← 0 Analog Input, Low Byte 1	Bit 7 ← 0 Counter Word 0, Low Byte
Byte 4 Bit 15 ← 8 Analog Input, High Byte 1	Bit 15 ← 8 Counter Word 0, High Byte
Byte 5 Bit 7 ← 0 Analog Input, Low Byte 2	Bit 7 ← 0 Counter Word 1, Low Byte
Byte 6 Bit 15 ← 8 Analog Input, High Byte 2	Bit 15 ← 8 Counter Word 1, High Byte
Byte 7 Bit 7 ← 0 Counter Word 0, Low Byte	
Byte 8 Bit 15 ← 8 Counter Word 0, High Byte	
Byte 9 Bit 7 ← 0 Counter Word 1, Low Byte	
Byte 10 Bit 15 ← 8 Counter Word 1, High Byte	

Figure 6. Example I/O Table

8. Diagnostics

a. LED Diagnostic Indicators

Figure 7 shows the definition for each LED on the bus coupler.

b. Diagnostic Objects

Note

A detailed explanation of the following can be found in the IL DN BK3 Users Manual.

Diagnostic information is available through mapped attributes from the Configuration Object, class code 100 (64 hex), found in the Inline DeviceNet™ IL DN BK3 Users Manual.

By default the Inline diagnostic data (Inline Status word) is made available to the user. Diagnostic data will start in byte 0 of the input area data table and takes up 2 bytes as shown in Figure 6.

Using the default mapping, the first byte of the produced response contains the Inline fault code status and the second byte contains the number of the first I/O module on the Inline station that is faulted.

Inline Status Byte 0

- Bit 7 Not Used
- Bit 6 Outputs Set to DeviceNet™ Fault States
- Bit 5 Module Connection Error
- Bit 4 Configuring Error (I/O can't be configured)
- Bit 3 Module Change Error
- Bit 2 Power Fault
- Bit 1 Peripheral Fault
- Bit 0 CRC Error

Inline Status Byte 1

Contains the device number which represents the position on the Inline station where a failure or warning has occurred. These positions are numbered starting at the IL DN BK3 being assigned with 1. The numbering will continue in physical order left to right up to 64 which is the maximum number of devices that can be connected to an Inline station. (63 I/O devices + 1 bus coupler)

9. Inline Fault Control

a. Fault Response Modes

Fault response is a configurable setting that will control the behavior of the Inline station outputs in the event of one of the 3 below listed errors occur:

- **Module Change Error**
 - Bit 3 in the Inline status word
- **Configuring Error**
 - Bit 4 in the Inline status word
- **Module Connection Error**
 - Bit 5 in the Inline status word

The IL DN BK3 has the ability to run in the fault response modes described in the following paragraphs.

(1) Fault Response Mode 0: Stop on Fault (Default)

Outputs are turned OFF automatically when a local failure occurs. Once the failure(s) is fixed, either a reconfiguration (Class 64 hex, Instance 1, Attribute 6) or a power cycle (U_L and DeviceNet™ power) needs to occur before the station becomes operational again.

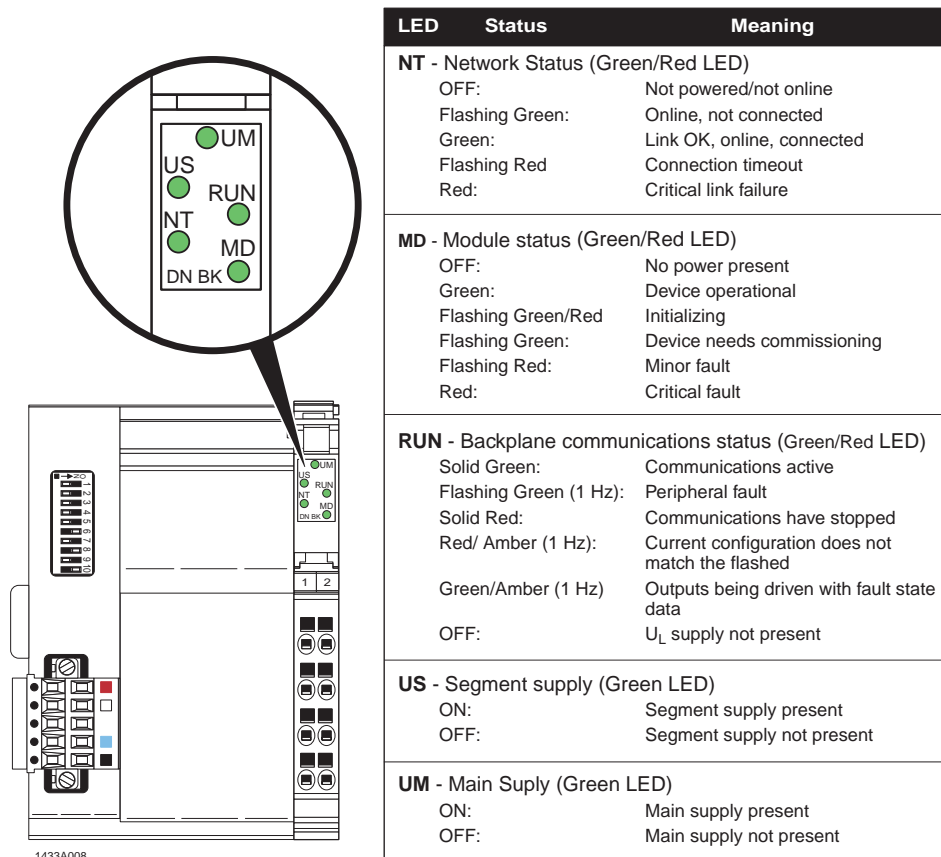

Figure 7. Status LEDs and Meanings

(2) Fault Response Mode 1: Auto Restart

Outputs are turned OFF automatically when a local failure occurs. Once a failure is fixed, the station will begin to update I/O automatically.

Fault Response modes 0 and 1 can be selected either by sending an explicit message or by selecting the mode in the Fault Response parameter in the EDS file.

(3) Fault Response Mode 2: Goto Fault State

Outputs are turned OFF automatically for up to two seconds when a local failure occurs. After two seconds the station will attempt to set the outputs to the pre-programmed DeviceNet™ fault states. The station will not recover its lost I/O, even after the fault condition has been cleared, without a reconfiguration or power cycle (U_L, DeviceNet™). The default for a preprogrammed fault state is OFF.

(4) Fault Response Mode 3: Continue on Fault

Outputs are turned OFF automatically for up to two seconds when a local failure occurs. After two seconds the station will continue to update all I/O that is

still on line. The station will not recover it's lost I/O, even after the fault condition is cleared, without a reconfiguration or power cycle (U_L, DeviceNet™).

Note

The use of Loop 2 I/O will only allow the station to operate in modes 0 or 1. If you are running your station in modes 2 or 3 and Loop 2 is added, the mode will automatically change to mode 0.

b. DeviceNet™ Fault State and Value Attributes

The IL DN BK3 supports the standard DeviceNet™ fault states and value attributes for digital and analog outputs. This will allow for the user to configure each instance of an output to go to the preprogrammed state and value in the event of a loss of DeviceNet™ communications. Preprogramming is accomplished through an explicit message and will be retained in flash memory. These states include:

- Hold last state/value
- Turn off (low limit for analog outputs)
- Turn on (high limit for analog outputs)
- Predetermined value (analog outputs)

10. Technical Data (see Tables 3 thru 12)

Table 3. General Bus Coupler Data.

Order designation	IL DN BK3-PAC
Order number	27 18 78 5
Housing dimensions (width x height x depth)	91 mm x 120 mm x 71.5 mm
Degree of protection	IP20 according to IEC 60536
Class of protection	Class 3, according to VDE 0106, IEC 60536
Weight	210 g (without connector)

1436A065

Table 4. Inline DeviceNet™ System Data

Transmission speed	500 kbits/s, 250 kbits/s, 125 kbits/s
Transmission reliability.....	CRC check
Maximum distance	500 m (1640 ft)
Protocol	control and information (CIP) with CAN as the transport layer
Nodes	64 maximum
Bus coupler voltage range (+V, -V)	11-28 V
Bus coupler nominal current (+V, -V)	45-50 mA
Bus coupler certification	ODVA

1436B062

Table 5 . Ambient Conditions

Regulations.....	developed according to VDE 0160, UL 508
Ambient temperature, operating.....	-25°C to +55°C
Ambient temperature, storage/transport	-25°C to +85°C
Temperature cycles (speed of changing from positive-to-negative and vice versa)....	0.5 K/min. (no condensation)
Humidity, operating.....	75% on average; 85% occasionally (no condensation)
Note: Ranging from -25°C to +55°C, appropriate measures must be taken against increased humidity (>85%).	
Humidity, storage/transport	75% average; 85% occasionally
Note: For a short period, slight condensation may appear on the housing, if for example, the terminal is brought into a closed room with a vehicle.	
Degree of protection according to IEC 60529	IP20
Degree of protection according to IEC 60536	Class 3
Housing material, basic.....	plastic Arnite PVC-Free PA6.6, self-extinguishing (V0)
Degree of pollution according to EN 50178.....	2; condensation not permissible in operation
Surge voltage class.....	II (low-level signal); III (power level)
Gases that endanger the functions (according to DIN 40046-36, DIN 40046-37)	
Sulphur dioxide (SO ₂) concentration 10 ± 0.3 ppm. Ambient conditions:	
Temperature	25°C (± 2°C)
Humidity	75% (± 5%)
Test duration.....	10 days
Hydrogen sulfide (H ₂ S) concentration 1 ± 0.3 ppm. Ambient conditions:	
Temperature	25°C (± 2°C)
Humidity	75% (± 5%)
Test duration.....	4 days
Resistance of the housing material to termites.....	resistant
Resistance of the housing material to fungi.....	resistant

1436A072

10. Technical Data (continued)

Table 6. Inline I/O System Data

Number of I/O devices in an Inline system	63 max.
Maximum current of the bus coupler module in the logic area (UL)	2 A
Maximum current consumption of the I/O modules	see module-specific data sheet
Maximum current carrying capacity of the voltage jumper U_{ANA}	0.5 A
Maximum current carrying capacity of the voltage jumpers U_M and U_S (total current)	8 A
<p>Note: Observe the current consumption of every device when configuring an Inline station. The logic current consumption values are listed in each terminal-specific data sheet. Current consumption can differ, depending on the type of module. If the maximum current carrying capacity of a voltage jumper (8 A) is reached, an additional power terminal must be used.</p>	

1605A006

Table 7. Bus Coupler Emissions Tests

Housing emissions	
Radiated.....	EN55011, Group 1, Class A
Conducted.....	EN55011, Group 1, Class A
Harmonic disturbances	EN61000-3-2

1436A059

Table 8. Mechanical Data

Vibration test according to IEC 60068-2-6	
Low-level signal, 24VDC, 120VAC, 230VAC areas	5 g load, 2 hours for each space direction (bus coupler, digital and analog I/O modules, etc.)
Power level, 400VAC areas (motor starter, etc.).....	2 g load, 2 hours for each space direction
Shock test according to IEC 60068-2-27	30 g load for 11 ms, half sinusoidal wave, three shocks in each space direction and orientation

1490A038

Table 9. Bus Coupler Immunity Tests

Immunity Test Regulations: EN61000-6-2:1999, In accordance with:	
Voltage fluctuations and flickers	EN61000-3-3
Electrostatic discharge (ESD)	EN 61000-4-2, Criteria B
Air discharge	±8 kV
Contact discharge	±6 kV
Continuous radiated fields.....	EN61000-4-3
Electrical fast transients (EFT) / bursts	EN 61000-4-4, Criteria B
AC/DC power ports.....	4 kV
Signal port	2 kV
Conducted immunity	EN61000-4-6, Criteria B, 10 V
Voltage surge	EN 61000-4-5, Criteria B
DC power port (differential and common)	±2 kV, ±1 kV, ±0.5 kV
Shield for Signal lines	±2 kV, ±1 kV, ±0.5 kV
Power frequency magnetic fields.....	EN 61000-4-8, Criteria A, 50 Hz, 30 A/m
Voltage dips and interruptions.....	EN 61000-4-11, Criteria B

1436A060

10. Technical Data (continued)

Table 10. U_L (7.5 Vdc Logic Supply)

Nominal voltage	7.5 V (converted from external 24 V dc)
Ripple	$\pm 5\%$
Load current	2 A maximum
Connection	voltage jumpers on the sides of the module housing

Notes:

1. Voltage is produced in the bus coupler by a DC/DC converter from the 24 V supply voltage.
2. U_L is not electrically isolated from the 24 V bus coupler voltage.
3. U_L is not electrically isolated from the I/O voltage U_M and U_S .
4. Communications power U_L is electronically short-circuit protected.

1436A067

Table 11. U_S and U_M (24 Vdc Digital Signal Supplies)

Nominal voltage	24 V dc
Tolerance	-15%/+20%
Ripple	$\pm 5\%$
Permissible voltage range	19 V dc to 30 V dc, ripple included
Load current	8 A maximum
Connection	voltage jumpers on the sides of the module housing

Notes:

1. Segment circuit U_S — All digital outputs and initiator supplies without individual short-circuit protection are connected to the segment circuit U_S .
2. Main circuit U_M — Initiator supplies with individual short-circuit protection are connected to the main U_M .

1436A066

Table 12. U_{ANA} (24Vdc Analog Supply)

Nominal voltage	24 V dc
Tolerance	-15%/+20%
Ripple	$\pm 5\%$
Permissible voltage range	19 V dc to 30 V dc, ripple included
Load current	500 mA maximum
Connection	voltage jumpers on the sides of the module housing

Notes:

1. Isolation of the 24 V input voltage by means of a diode.
2. Smoothing through π -filter; corner frequency 9.8 kHz and attenuation of 40 dB/decade.
3. U_{ANA} is not electrically isolated from the 24 V bus coupler supplies and the 7.5 V communications power.

1436A069

11. DeviceNet™ Class Services and Object Classes (see Tables 13 and 14)

Table 13. IL DN BK3 Supported DeviceNet™ Class Services

Service Code	Service Name
05 (0x05)	Reset
14 (0x0E)	Get_Attribute_Single
16 (0x10)	Set_Attribute_Single

1110A160

Table 14. IL DN BK3 Supported DeviceNet™ Object Classes

Class Code	Object Type
01 (0x01)	Identity
02 (0x02)	Router
03 (0x03)	DeviceNet
05 (0x05)	Connection
08 (0x08)	Digital Input Point
09 (0x09)	Digital Output Point
10 (0x0A)	Analog Input Point
11 (0x0B)	Analog Output Point
43 (0x2D)	Acknowledge Handler
100 (0x64)	Configuration Object
101 (0x65)	Inline Interface Object
102 (0x66)	Inline Module Object
103 (0x67)	Inline Special Function Object
104 (0x68)	COS Mask Object
105 (0x69)	PCP Special Function Object
106 (0x70)	Serial Communications Object

1436B054

12. Ordering Data (see Tables 15 and 16)

Table 15. IL DN BK3 Ordering Information

Description	Type	Order Number
DeviceNet™ Inline Bus Coupler(includes connectors & end clamps)	IL DN BK3-PAC	27 18 78 5
DeviceNet™ IL DN BK3 Users Manual	IL DN BK3 UM E	56 03 32 6

1435A003

Table 16. Accessories

Description	Type	Order No.	Pcs/Pkt
Coding Profile (see COMBICON catalog)	CP-MSTB	17 34 63 4	100
Zack "Quick" Marker Strips for labeling terminals (see CLIPLINE catalog)	Marking Strips	ZBFM6..	—
Labeling Field, 2-row width	IB IL Field 2	27 27 50 1	10
Labeling Field, 8-row width	IB IL Field 8	27 27 51 5	10
DIN-Rail, perforated	NS 35/7.5	08 01 73 3	2 meters
DIN-Rail, unperforated	NS 35/7.5	08 01 68 1	2 meters
End Clamp	CLIPFIX 35	30 22 21 8	50
Grounding Terminal Block, 10 to 24 AWG	USLKG 5	04 41 50 4	50
Screwdriver, blade type, 3.5 mm wide	SZF 1	12 04 51 7	1
Wire stripper, 10 to 30 AWG	QUICK-WIREFOX 6	12 04 38 4	1
Wire stripper, up to 25 mm insulation dia.	KAMES 2	12 06 00 7	1
Power supply, 120 V ac to 24 V dc, 1 amp	QUINT-PS 120AC/24DC/1	29 39 24 7	1
Power supply, 120 V ac to 24 V dc, 2.5 amp	QUINT-PS 120AC/24DC/2.5	29 39 05 6	1
Power supply, 120 V ac to 24 V dc, 5 amp	QUINT-PS 120AC/24DC/5	29 39 06 9	1
Power supply, 120 V ac to 24 V dc, 10 amp	QUINT-PS 120AC/24DC/10	29 39 07 2	1
Power supply, 230 V ac to 24 V dc, 1 amp	QUINT-PS 230AC/24DC/1	29 39 44 1	1
Power supply, 230 V ac to 24 V dc, 2.5 amp	QUINT-PS 230AC/24DC/2.5	29 39 15 3	1
Power supply, 230 V ac to 24 V dc, 5 amp	QUINT-PS 230AC/24DC/5	29 39 16 6	1
Power supply, 230 V ac to 24 V dc, 10 amp	QUINT-PS 230AC/24DC/10	29 39 17 9	1
Power Connector, with color code	IB IL SCN-PWR IN-CP	27 27 63 7	10
Power Connector, without color code	IB IL SCN-PWR IN	27 27 46 2	10
I/O Connector, 2 signals, 4-wire connection, without color code	IB IL SCN-8	27 26 33 7	10
I/O Connector, 2 signals, 4-wire connection, color coded	IB IL SCN-8-CP	27 27 60 8	10
I/O Connector, 4 signals, 3-wire connection, without color code	IB IL SCN-12	27 26 34 0	10
I/O Connector, digital input modules, 4 signals, 3-wire connection, color coded	IB IL SCN-12-ICP	27 27 61 1	10
I/O Connector, digital output modules, 4 signals, 3-wire connection, color coded	IB IL SCN-12-OCP	27 27 62 4	10
I/O Connector with shield clamp	B IL SCN-6 SHIELD	27 26 35 3	5
Bus Coupler Network Connector	MSTBP 2,5/5-STF-5.08 AU PRTD	28 62 57 6	50

1605A007

NOTES

A large grid of graph paper for taking notes, consisting of approximately 30 columns and 40 rows of small squares.

0001A164

The information given herein is based on data believed to be reliable, but Phoenix Contact Inc. makes no warranties expressed or implied as to its accuracy and assumes no liability arising out of its use by others. This publication is not to be taken as a license to operate under, or recommendation to infringe, any patent.

Headquarters, U.S.

Phoenix Contact Inc.
P.O. Box 4100
Harrisburg, PA 17111-0100
Phone: 800-888-7388
717-944-1300
Fax: 717-944-1625
Email: info@phoenixcon.com
Website: www.phoenixcon.com

Technical Service
Phone: 800-322-3225

Headquarters, Canada

Phoenix Contact Ltd.
235 Watline Avenue
Mississauga, Ontario L4Z 1P3
Phone: 905-890-2820
Fax: 905-890-0180

Technical Service
Phone: 800-890-2828





SCATTERGOOD & JOHNSON LTD

ELECTRICAL ENGINEERING & FLUID CONTROL DISTRIBUTORS

Est.1899

At Scattergood & Johnson Ltd, we pride ourselves on being a technical distributor to specialist industries.

Working with a range of quality product suppliers across a number of specialist markets, we are not your average 'box shifter' - we are your technical and supply chain partner.

We fully support every product we sell - for free! Our internal team and external sales engineers can answer any product or application question, no matter the complexity.

Backing up this technical ability is a range of 50,000+ products available from stock for nationwide next day delivery (same day if required!), or you can collect what you need from any of our trade counters around the UK.

Select your specialist interest below to learn more about how we can help.



Online, In Branch and On the Road - Scattergood & Johnson Ltd, there when you need us.

www.scatts.co.uk