

FLS PB M12 DI 16 M12

Fieldline Stand-Alone device for PROFIBUS DP
with 16 digital inputs

AUTOMATION

Data sheet
6866_en_02

© PHOENIX CONTACT - 01/2009

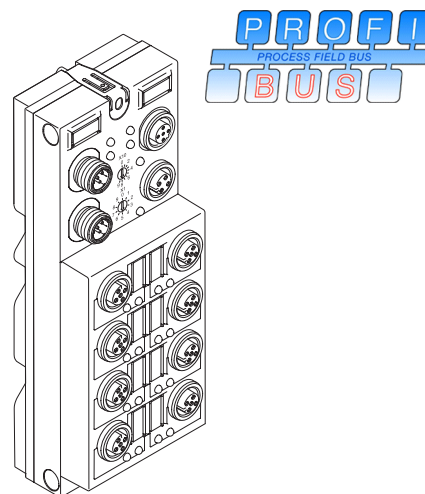

1 Description

This device is used to acquire digital signals.

Features

- Connection to PROFIBUS DP using M12 connectors (B-encoded)
- Baud rate with up to 12 Mbaud autobaud
- Connection of digital sensors using M12 connectors
- Flexible power supply concept
- Diagnostic and status indicators
- Short-circuit and overload protection of the sensor supply
- IP65/IP67 protection



Make sure you always use the latest documentation.
It can be downloaded at www.phoenixcontact.com.



This data sheet is only valid in association with the FLS FLM SYS INST UM E and FLS FLM PB SYS PRO UM E user manuals.

2 Ordering data

Products

Description	Type	Order No.	Pcs./Pkt.
Fieldline Stand-Alone device for PROFIBUS with 16 digital inputs	FLS PB M12 DI 16 M12	2736220	1

Accessories

Description	Type	Order No.	Pcs./Pkt.
Protective caps (for unused female connectors)	PROT-M12	1680539	5
Protective caps (for unused male connectors)	PROT-M12-FS	1513596	5
5-pos. shielded female connector, M12 B-encoded, for the incoming remote bus	SACC-M12FSB-5CON-PG9 SH AU	1507777	1
5-pos. shielded male connector, M12 B-encoded, for the outgoing remote bus	SACC-M12MSB-5CON-PG9 SH AU	1507764	1
PROFIBUS M12 T-piece, 12 Mbaud	SAC-M12T/2XM12 PB DP	1507780	1
PROFIBUS M12 termination resistor	SAC-5P-M12MS PB TR	1507803	1
Marking labels	ZBF 12:UNBEDRUCKT	0809735	10



For additional accessories for connecting the sensors, please refer to the Phoenix Contact PLUSCON catalog.

Documentation

Description	Type	Order No.	Pcs./Pkt.
"Installation of devices in the Fieldline product range" user manual	FLS FLM SYS INST UM E	-	-
"Configuring a PROFIBUS system using devices in the Fieldline product range" user manual	FLS FLM PB SYS PRO UM E	-	-

3 Technical data

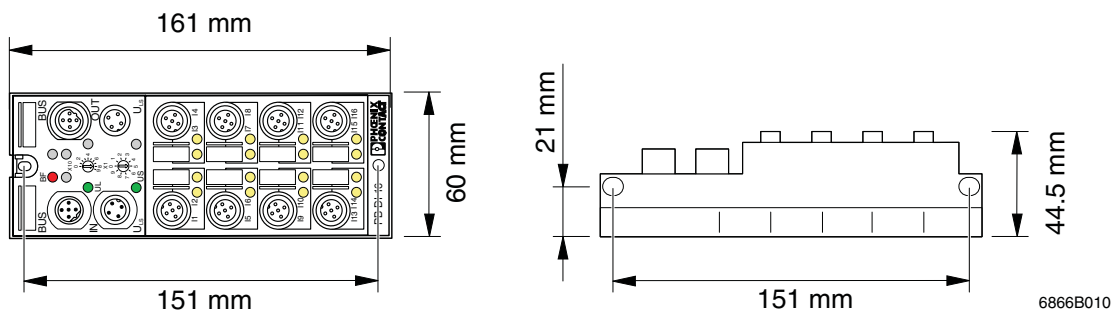

Figure 1 Dimensions of the device

General data

Order designation	FLS PB M12 DI 16 M12
Order No.	2736220
Housing dimensions (width x height x depth)	60 mm x 161 mm x 44.5 mm
Weight	310 g, approximately
Operating mode	Process data mode with 16 bits
Connection method for sensors	2, 3 or 4-wire technology
Permissible temperature (operation)	-25°C to +60°C
Permissible temperature (storage/transport)	-25°C to +85°C
Permissible humidity (storage/transport)	95%



For a short period, slight condensation may appear on the outside of the housing.

Permissible air pressure (operation)	80 kPa to 106 kPa (up to 2000 m above sea level)
Permissible air pressure (storage/transport)	70 kPa to 106 kPa (up to 3000 m above sea level)
Degree of protection	IP65/IP67 according to IEC 60529
Protection class	Class 3 according to VDE 0106, IEC 60536

Mechanical requirements

Vibration test, sinusoidal vibrations according to EN 60068-2-6	5g load in each space direction
Shock test according to EN 60068-2-27	30g load, half sinusoidal wave positive and negative in each space direction



For additional information about mechanical requirements and ambient conditions, please contact Phoenix Contact.

Power supply

Supply voltage	24 V DC
Range	11 V DC to 30 V DC
Current consumption at U_{L+} at 24 V DC	35 mA, typical (100 mA, maximum)
Current consumption at U_S at 24 V DC	8 mA + sensor current, typical (1.2 A, maximum)

Digital inputs

Number	16
Input design	According to IEC 61131-2 Type 1
Definition of switching thresholds	
Maximum low-level voltage	$U_{Lmax} < 5 \text{ V}$
Minimum high-level voltage	$U_{Hmin} > 11 \text{ V}$
Nominal input voltage	24 V DC
Range	-3 V DC < U_{IN} < +30 V DC
Nominal input current	3 mA
Current flow	Constant
Delay time	$t_{ON} < 1 \text{ ms}$, typical $t_{OFF} = 2 \text{ ms}$, typical
Permissible cable length to the sensor	100 m

Sensor supply

Minimum sensor voltage	$U_S - 1 \text{ V}$
Nominal current per channel	75 mA
Nominal current per device	1.2 A
Overload protection	Electronic per device
Short-circuit protection	Electronic per device

Error messages to the higher-level control or computer system

Sensor supply short circuit	Yes
Sensor supply overload	Yes



If an error is triggered by an overload or short circuit of the sensor supply, the device switches off the sensor supply to all the channels and sends an error message to the master.

If the sensor supply U_S is too low, the device sends an error message to the master (see "Diagnostic data" on page 10).

Interface

Bus system	PROFIBUS DP
------------	-------------

Incoming bus

Coupling of shield connection	Directly to FE
Transmission speed	12 Mbaud, maximum

Outgoing bus

Coupling of shield connection	Directly to FE
Transmission speed	12 Mbaud, maximum



For transmission speeds of more than 3 Mbaud, T-pieces with integrated series inductance must be used.

Electrical isolation/isolation of the voltage areas



For device connection, please note the instructions and regulations in the "Installation of devices in the Fieldline product range" user manual, FLS FLM SYS INST UM E.

Separate potentials in the FLS PB M12 DI 16 M12 input device

Test distance	Test voltage
24 V supply (bus logic)/bus connection	500 V AC, 50 Hz, 1 min.
24 V supply (bus logic)/FE	500 V AC, 50 Hz, 1 min.
24 V supply (bus logic)/digital inputs (sensor supply)	500 V AC, 50 Hz, 1 min.
Bus connection/FE	500 V AC, 50 Hz, 1 min.
Bus connection/digital inputs (sensor supply)	500 V AC, 50 Hz, 1 min.
FE/digital inputs (sensor supply)	500 V AC, 50 Hz, 1 min.

Approvals

For the latest approvals, please visit www.download.phoenixcontact.com or eshop.phoenixcontact.com.

4 Pin assignment

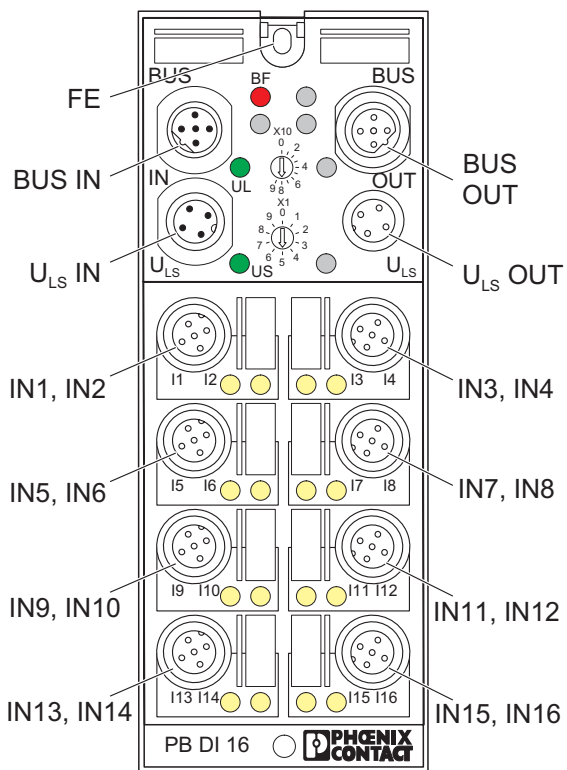

Designation	Meaning
FE	Functional earth ground
BUS IN	PROFIBUS IN
BUS OUT	PROFIBUS OUT
ULS IN	Power supply IN (logic and sensors)
ULS OUT	Power supply OUT (logic and sensors) for additional devices
IN1 to IN16	Inputs 1 to 16

6866A002

Figure 2 Connections of the FLS PB M12 DI 16 M12

4.1 PROFIBUS pin assignment

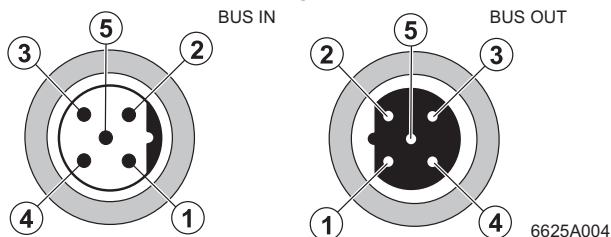

Figure 3 Pin assignment of the PROFIBUS connection (M12 B-encoded)

Pin	IN	OUT
1	VP	VP
2	RxD/TxD-N (A)	RxD/TxD-N (A)
3	DGND	DGND
4	RxD/TxD-P (B)	RxD/TxD-P (B)
5	Shield	Shield



The thread is used for additional shielding.

4.2 Pin assignment of the power supply U_{LS}

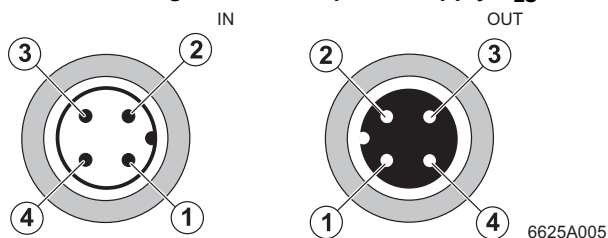

Figure 4 Pin assignment of the power supply U_{LS}

Pin	IN	OUT
1	$U_L +24\text{ V}$	$U_L +24\text{ V}$
2	$U_S\text{ GND}$	$U_S\text{ GND}$
3	$U_L\text{ GND}$	$U_L\text{ GND}$
4	$U_S +24\text{ V}$	$U_S +24\text{ V}$

4.3 Pin assignment of the inputs

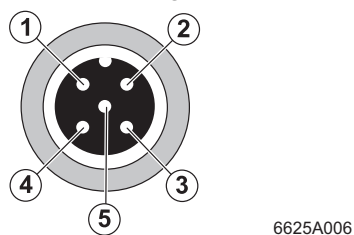
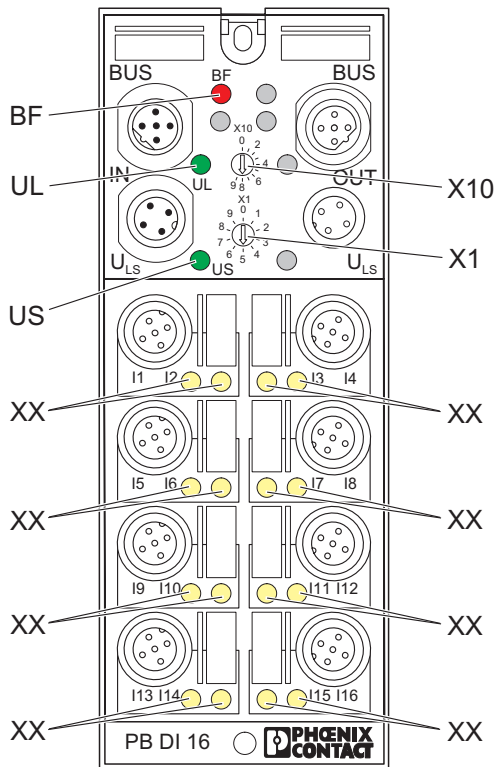

Figure 5 Pin assignment of the inputs

Pin	Female input connector
1	$U_S +24\text{ V}$
2	Input 2, 4, 6, ... 16
3	GND
4	Input 1, 3, 5, ... 15
5	FE

5 Local diagnostic and status indicators



6866A003

Figure 6 Indicators and rotary encoding switches of the FLS PB M12 DI 16 M12

Rotary encoding switches

The station address is set using rotary encoding switches X10 (for tens) and X1 (for units). The PROFIBUS master addresses the device by means of this station address.



The valid value range is between 1 and 99.
A new address value is only applied on device power up.

Des.	Color	Meaning
BF	Red LED	Bus error (bus failure)
		ON: No cyclic data transmission: <ul style="list-style-type: none"> - PROFIBUS not connected, master not active - Incorrect settings (configuration via master, station address) - Synchronization or parameterization running - Timeout elapsed OFF: <ul style="list-style-type: none"> - Device is addressed by PROFIBUS and is in the "cyclic process data exchange" state - Device supply not present (In this state the "UL" LED is also off due to the missing 24 V communications power.)
UL	Green LED	Communications power
		ON: Communications power present
		OFF: Communications power too low
US	Red/green LED	Power supply for IN1 to IN16
		ON (red): Power supply for IN1 to IN16 overloaded
		ON (green): Power supply for IN1 to IN16 present
		OFF: Power supply for IN1 to IN16 too low
XX	Yellow LED	Status indicators for the inputs
		ON: Input active
		OFF: Input not active

6 Internal basic circuit diagram

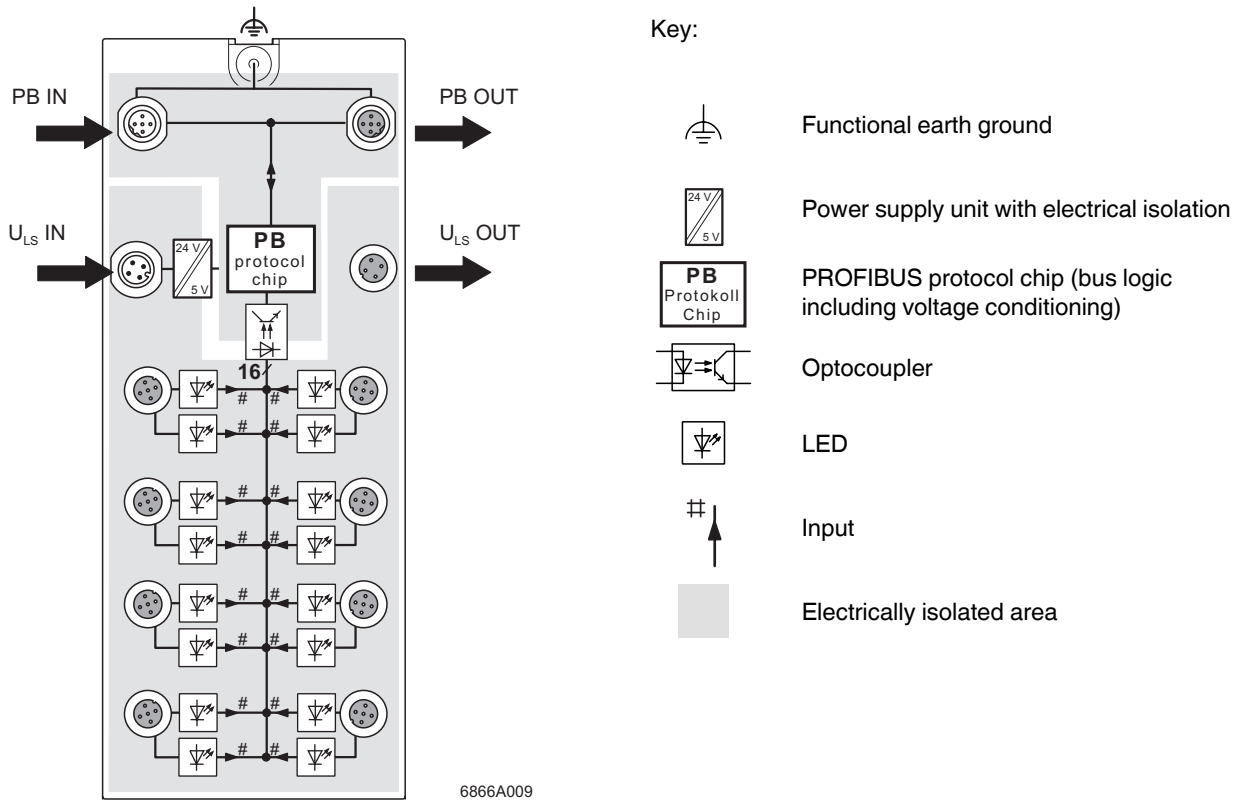

Figure 7 Internal wiring of the connections



For information about the electrically isolated areas, please refer to page 4.

7 Connection example

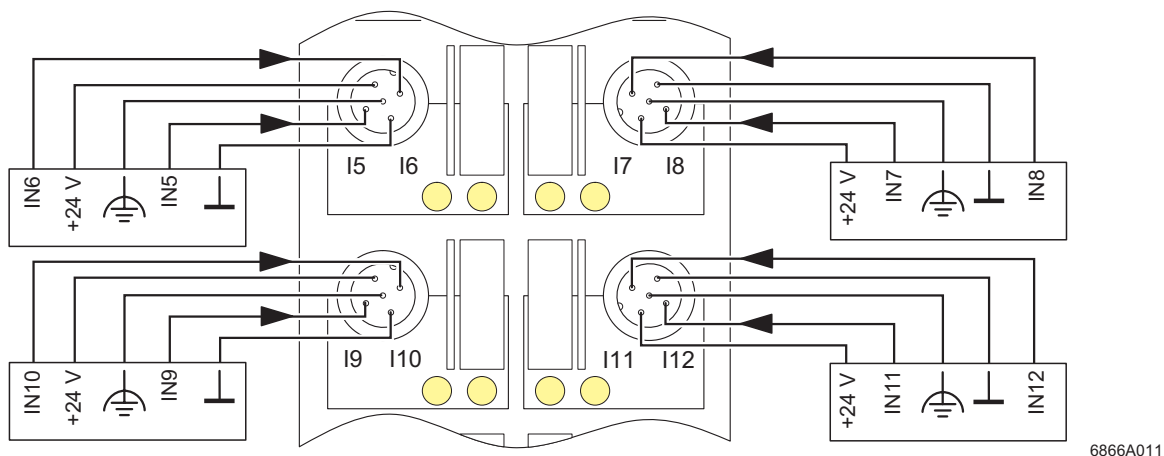

Figure 8 Typical connection of sensors

6866A011

8 Connection notes



NOTE: Meet noise immunity requirements

Connect FE using a mounting screw or a cable connection to the FE connection latch (when mounting on the side or on a non-conductive surface).



NOTE: Ensure degree of protection

To ensure IP65/IP67 protection, cover unused female connectors with protective caps.



NOTE: Avoid damage to the electronics

Only supply the sensors with the voltage U_S provided at the terminal points.



NOTE: Avoid polarity reversal

Avoid polarity reversal of the supply voltages U_L and U_S in order to prevent damage to the device.



NOTE: Observe connection assignment

When connecting the sensors, observe the assignment of the connections to the PROFIBUS input data (see "Process data" on page 10).

9 Configuration data

ID number	06FB _{hex}
Input address area	16 bits

10 Process data

10.1 Assignment of the terminal points to the IN process data

(Word.byte) view	Word	Word 0															
(Byte.bit) view	Byte	Byte 0								Byte 1							
	Bit	7	6	5	4	3	2	1	0	7	6	5	4	3	2	1	0
Device	Input	8	7	6	5	4	3	2	1	16	15	14	13	12	11	10	9

11 Diagnostic data

11.1 Mapping of diagnostic data in PROFIBUS

Diagnostic data	Bit 7	Bit 6	Bit 5	Bit 4	Bit 3	Bit 2	Bit 1	Bit 0	Remark
Byte 0	X	X	X	X	X	X	X	X	Station status 1
Byte 1	X	X	X	X	X	X	X	X	Station status 2
Byte 2	X	X	X	X	X	X	X	X	Station status 3
Byte 3	X	X	X	X	X	X	X	X	Diagnostic master address
Byte 4	0	0	0	0	0	1	1	0	High ID number
Byte 5	0	1	1	0	1	0	1	1	Low ID number
Byte 6	0	0	0	0	0	1	1	1	Diagnostic header
Byte 7	M.7	M.6	M.5	M.4	M.3	M.2	M.1	M.0	Device diagnostics (see page 10)
Byte 8	0	0	0	0	0	0	0	0	Reserved
Byte 9	0	0	0	0	0	0	0	0	Reserved
Byte 10	0	0	0	0	0	0	0	0	Reserved
Byte 11	0	0	0	0	0	0	0	0	Reserved
Byte 12	X	X	0	0	0	0	0	0	Reserved



Bytes 0 to 6 are PROFIBUS standard. Bytes 7 to 12 are device-specific.

11.2 Diagnostic data for device diagnostics

Bit	Remark	Assignment
M.0 - M.2	Reserved	0
M.3	Status of the sensor supply U_S	1, if U_S is too low
M.4 - M.5	Reserved	0
M.6	Status of the device supply U_L	1, if U_L too low
M.7	Overload status of the sensor supply U_S	1, if sensor supply is overloaded



SCATTERGOOD & JOHNSON LTD

ELECTRICAL ENGINEERING & FLUID CONTROL DISTRIBUTORS

Est.1899

At Scattergood & Johnson Ltd, we pride ourselves on being a technical distributor to specialist industries.

Working with a range of quality product suppliers across a number of specialist markets, we are not your average 'box shifter' - we are your technical and supply chain partner.

We fully support every product we sell - for free! Our internal team and external sales engineers can answer any product or application question, no matter the complexity.

Backing up this technical ability is a range of 50,000+ products available from stock for nationwide next day delivery (same day if required!), or you can collect what you need from any of our trade counters around the UK.

Select your specialist interest below to learn more about how we can help.



Online, In Branch and On the Road - Scattergood & Johnson Ltd, there when you need us.

www.scatts.co.uk