

AUTOMATION



User Manual

FLS FLM SYS INST UM E

Installation of Devices in the Fieldline Product Range

AUTOMATION

User Manual

Installation of Devices in the Fieldline Product Range

06/2010

Designation: FLS FLM SYS INST UM E

Revision: 07

This user manual is valid for:

Devices of the Fieldline product range connected to different bus systems

Please observe the following notes

In order to ensure the safe use of the product described, you have to read and understand this manual. The following notes provide information on how to use this manual.

User group of this manual

The use of products described in this manual is oriented exclusively to qualified electricians or persons instructed by them, who are familiar with applicable standards and other regulations regarding electrical engineering and, in particular, the relevant safety concepts.

Phoenix Contact accepts no liability for erroneous handling or damage to products from Phoenix Contact or third-party products resulting from disregard of information contained in this manual.

Explanation of symbols used and signal words



This is the safety alert symbol. It is used to alert you to potential personal injury hazards. Obey all safety messages that follow this symbol to avoid possible injury or death.



DANGER

This indicates a hazardous situation which, if not avoided, will result in death or serious injury.



WARNING

This indicates a hazardous situation which, if not avoided, could result in death or serious injury.



CAUTION

This indicates a hazardous situation which, if not avoided, could result in minor or moderate injury.

The following types of messages provide information about possible property damage and general information concerning proper operation and ease-of-use.



NOTE

This symbol and the accompanying text alerts the reader to a situation which may cause damage or malfunction to the device, either hardware or software, or surrounding property.



This symbol and the accompanying text provides additional information to the reader. It is also used as a reference to other sources of information (manuals, data sheets, literature) on the subject matter, product, etc.

**For use in potentially explosive environments, please observe the following:**

- THIS EQUIPMENT IS SUITABLE FOR USE IN CLASS I, DIVISION 2, GROUPS A, B, C AND D OR NON-HAZARDOUS LOCATIONS ONLY.
- WARNING - EXPLOSION HAZARD - SUBSTITUTION OF COMPONENTS MAY IMPAIR SUITABILITY FOR CLASS I, DIVISION 2.
- WARNING - EXPLOSION HAZARD - DO NOT DISCONNECT EQUIPMENT UNLESS POWER HAS BEEN SWITCHED OFF OR THE AREA IS KNOWN TO BE NON-HAZARDOUS.
- ALL WIRING OF THESE DEVICES MUST BE IN ACCORDANCE WITH THE NATIONAL ELECTRICAL CODE ARTICLE 501.4(B) FOR CLASS I, DIVISION 2.

We Are Interested in Your Opinion

We are constantly striving to improve the quality of our manuals.

Should you have any suggestions or recommendations for improvement of the contents and layout of our manuals, please send us your comments.

PHOENIX CONTACT GmbH & Co. KG
Documentation Services
32823 Blomberg
Germany

Phone +49 - 52 35 - 30 0
Fax + 49 - 52 35 - 34 20 21
E-mail tecdoc@phoenixcontact.com

General terms and conditions of use for technical documentation

Phoenix Contact reserves the right to alter, correct, and/or improve the technical documentation and the products described in the technical documentation at its own discretion and without giving prior notice, insofar as this is reasonable for the user. The same applies to any technical changes that serve the purpose of technical progress.

The receipt of technical documentation (in particular data sheets, installation instructions, manuals, etc.) does not constitute any further duty on the part of Phoenix Contact to furnish information on alterations to products and/or technical documentation. Any other agreement shall only apply if expressly confirmed in writing by Phoenix Contact. Please note that the supplied documentation is product-specific documentation only and that you are responsible for checking the suitability and intended use of the products in your specific application, in particular with regard to observing the applicable standards and regulations. Although Phoenix Contact makes every effort to ensure that the information content is accurate, up-to-date, and state-of-the-art, technical inaccuracies and/or printing errors in the information cannot be ruled out. Phoenix Contact does not offer any guarantees as to the reliability, accuracy or completeness of the information. All information made available in the technical data is supplied without any accompanying guarantee, whether expressly mentioned, implied or tacitly assumed. This information does not include any guarantees regarding quality, does not describe any fair marketable quality, and does not make any claims as to quality guarantees or guarantees regarding the suitability for a special purpose.

Phoenix Contact accepts no liability or responsibility for errors or omissions in the content of the technical documentation (in particular data sheets, installation instructions, manuals, etc.).

The aforementioned limitations of liability and exemptions from liability do not apply, in so far as liability must be assumed, e.g., according to product liability law, in cases of premeditation, gross negligence, on account of loss of life, physical injury or damage to health or on account of the violation of important contractual obligations. Claims for damages for the violation of important contractual obligations are, however, limited to contract-typical, predictable damages, provided there is no premeditation or gross negligence, or that liability is assumed on account of loss of life, physical injury or damage to health. This ruling does not imply a change in the burden of proof to the detriment of the user.

FLS FLM SYS INST UM E

Statement of legal authority

This manual, including all illustrations contained herein, is copyright protected. Use of this manual by any third party is forbidden. Reproduction, translation, and public disclosure, as well as electronic and photographic archiving or alteration requires the express written consent of Phoenix Contact. Violators are liable for damages.

Phoenix Contact reserves all rights in the case of patent award or listing of a registered design. Third-party products are always named without reference to patent rights. The existence of such rights shall not be excluded.

How to contact us**Internet**

Up-to-date information on Phoenix Contact products and our Terms and Conditions can be found on the Internet at:

www.phoenixcontact.com.

Make sure you always use the latest documentation.

It can be downloaded at:

www.phoenixcontact.net/download.

Subsidiaries

If there are any problems that cannot be solved using the documentation, please contact your Phoenix Contact subsidiary.

Subsidiary contact information is available at www.phoenixcontact.com.

Published by

PHOENIX CONTACT GmbH & Co. KG
Flachmarktstraße 8
32825 Blomberg
Germany
Phone +49 - (0) 52 35 - 3-00
Fax +49 - (0) 52 35 - 3-4 12 00

PHOENIX CONTACT
P.O. Box 4100
Harrisburg, PA 17111-0100
USA
Phone +1-717-944-1300

Should you have any suggestions or recommendations for improvement of the contents and layout of our manuals, please send your comments to

tecdoc@phoenixcontact.com.

Table of Contents

1	Fieldline	1-1
1.1	The Fieldline Product Range	1-1
1.2	Documentation for Fieldline Devices	1-4
1.3	Product Description of the Fieldline Stand-Alone Devices.....	1-5
1.4	Product Description of the Fieldline Modular M12 Devices.....	1-6
1.5	Product Description of the Fieldline Modular M8 Devices.....	1-8
1.6	For Your Safety.....	1-9
1.6.1	Correct Usage	1-9
1.6.2	Regulations	1-9
1.6.3	Safety Notes	1-9
1.7	Using Fieldline Devices in Safety Applications	1-9
2	Description of the Fieldline Stand-Alone Devices	2-1
2.1	Housing Versions for Fieldline Stand-Alone Devices.....	2-1
2.2	Housing Dimensions for Fieldline Stand-Alone Devices.....	2-2
2.3	Basic Structure of the Fieldline Stand-Alone Devices.....	2-3
2.4	Labeling for Fieldline Stand-Alone Devices	2-4
2.5	Diagnostic and Status Indicators of the Fieldline Stand-Alone Devices.....	2-5
3	Description of Fieldline Modular Devices	3-1
3.1	Housing Versions for Fieldline Modular Devices	3-1
3.2	Housing Dimensions for Fieldline Modular Devices.....	3-2
3.3	Basic Structure of the Fieldline Modular Devices.....	3-3
3.3.1	Structure of Fieldline Modular Bus Couplers	3-3
3.3.2	Structure of the Digital Fieldline Modular Input and Output Devices (M12)	3-4
3.3.3	Structure of the Analog Fieldline Modular Input and Output Devices (M12)	3-5
3.3.4	Structure of the Fieldline Modular Bluetooth Base Station	3-6
3.3.5	Structure of a Digital Fieldline Modular Bluetooth Device	3-7
3.3.6	Structure of the Digital Fieldline Modular Input and Output Devices (M8)	3-8
3.4	Labeling of the Fieldline Modular Devices	3-8
3.5	Diagnostic and Status Indicators of the Fieldline Modular Devices.....	3-9
3.6	Structure of a Fieldline Modular Station.....	3-14
4	Mounting Fieldline Devices and Connecting Cables	4-1
4.1	General Information on Installation	4-1
4.1.1	Installing Bus Lines Between Buildings	4-3
4.1.2	Interference Suppression Measures	4-4
4.1.3	Grounding Concept	4-4
4.2	Installation Instructions	4-5

FLS FLM SYS INST UM E

4.3	Mounting Distances	4-5
4.4	Mounting Fieldline Stand-Alone Devices	4-6
4.4.1	Front Mounting for Fieldline Stand-Alone Devices	4-7
4.4.2	Side Mounting for Fieldline Stand-Alone Devices	4-9
4.5	Mounting Fieldline Modular Devices	4-10
4.5.1	Direct Mounting on a Flat Mounting Surface	4-10
4.5.2	Mounting on a Mounting Plate	4-13
4.6	Setting the Address and Transmission Speed for Fieldline Devices	4-15
4.7	Connecting the Power Supply	4-17
4.7.1	Power Supplies U_L and U_S	4-17
4.7.2	Power Supply U_A	4-22
4.7.3	Power Supply for Sensors and Actuators in Individual Fieldline Stand-Alone Devices	4-25
4.7.4	Power Supply for Sensors and Actuators in Individual Fieldline Modular M12 Devices	4-27
4.7.5	Power Supply for Sensors and Actuators in Individual Fieldline Modular M8 Devices	4-30
4.7.6	Voltage Supply Examples	4-32
4.7.7	Calculation Examples for Sensor and Actuator Currents	4-36
4.7.8	Supply Line and Current Supply (M12)	4-46
4.7.9	Supply Line and Current Supply (M8)	4-47
4.8	Connecting Sensors and Actuators	4-48

1 Fieldline

1.1 The Fieldline Product Range

The input and output devices in the Fieldline product range are designed for distributed automation tasks in harsh environmental conditions. The devices meet the requirements for IP65/IP67 protection. They enable direct connection of sensors and actuators in an environment close to the station.

The Fieldline product range includes the Fieldline Stand-Alone (FLS) and Fieldline Modular (FLM) product groups. FLS devices are available in M12 connection method. With FLM devices you can choose between M12 and M8 connection method. If not mentioned explicitly, the M12 connection method is used in this manual.







Fieldline Stand-Alone devices cannot be extended and have a directly integrated fieldbus connection and I/O level. They are used for distribution in the field when only a few digital I/O points are required.

Fieldline Modular systems consist of a bus coupler (gateway) and I/O devices that can be connected. They are used for special functions, primarily for applications with a high I/O node density and complex functions.

Directly on the field level the Fieldline Modular M8 devices complement the Fieldline product range to form a sophisticated system. The Fieldline Modular M8 devices are perfectly designed for acquisition and output of signals in the direct proximity to the process when only limited space is available.

Bus systems

The Fieldline devices are available for the following bus systems:

INTERBUS	
PROFIBUS-DP	
PROFINET	
DeviceNet™	
CANopen	
Ethernet	

FLS FLM SYS INST UM E

The following tables provide an overview of the meaning of the product designations used within the Fieldline product range.

Table 1-1 Structure of the product designation

Type	Basic Devices	Fieldbus	Bus Connection	I/O Type	I/O Connection	Extension
FLS		IB	M12	DI x	M8	-2A
FLM	BK	PB	M8	DO y	M12	DIAG
		DN		DIO x/y		RTD
		CO		AI		2TX
		ETH		AO		SF
		EIP		IOL		EF
		PN		TEMP		

Examples:

FLS		PB	M12	DIO 4/4	M12	-2A
FLM	BK	IB	M12	DI 8	M12	
FLM				AI 4 SF	M12	
FLM				DIO8/4	M8	

Table 1-2 Structure of the product designation for Bluetooth devices

Type	Bus Connection	Basic Device	Type	I/O Type	I/O Connection
FLM	BT	BS	3		
FLM	BT		P2P	DIO x/y	M12

Examples:

FLM	BT	BS	3		
FLM	BT			DIO 8/8	M12

Table 1-3 Meaning of the product designation

Abbrev.	Meaning
FLS	Fieldline Stand-Alone
FLM	Fieldline Modular
BK	Bus coupler
BS	Base station
IB	INTERBUS
PB	PROFIBUS-DP
DN	DeviceNet™
CO	CANopen
ETH	Ethernet
BT	Bluetooth
EIP	Ethernet IP
PN	PROFINET
P2P	Point-to-point
M8	M8 connector
M12	M12 connector
DI x	x digital inputs
DO y	y digital outputs
DIO x/y	x digital inputs; y digital outputs
AI x SF	x analog inputs, (standard function)
AO y SF	y analog outputs, (standard function)
-2A	Nominal current of an output is 2 A
DIAG	Extended diagnostics
RTD	Shunt
2TX	2 ports, twisted pair
IOL	IO link
TEMP	Temperature
EF	Extended function

1.2 Documentation for Fieldline Devices

The documentation for Fieldline devices is modular, providing you with the optimum information for your specific bus system.

User manual: Installation of Devices in the Fieldline Product Range

This user manual describes the Fieldline Stand-Alone and Fieldline Modular devices for all bus systems. This includes:

- The device properties, which are the same for all bus systems
- Mounting
- The power supply concept
- Station structure examples

User manuals: Configuring a ... System Using Devices in the Fieldline Product Range

User manuals for the bus systems

INTERBUS	DeviceNet™
PROFIBUS-DP	CANopen
PROFINET	Ethernet

A separate user manual is available for each bus system.

Each user manual describes the special features of the Fieldline Stand-Alone and Fieldline Modular devices when used in the relevant bus system.

Device-Specific Data Sheets

The data sheet describes the specific properties of a device. This includes:

- Function
- Ordering data
- Technical data
- Local diagnostic and status indicators
- Connector pin assignment and connection example
- Programming data/configuration data



This user manual only describes the Fieldline Stand-Alone and Fieldline Modular devices without reference to the specific bus system. For complete information, please refer to the Fieldline user manual for your bus system and the data sheets for the devices used.



The Phoenix Contact AUTOMATION and PLUSCON catalogs contain the ordering data for all Fieldline products.

This includes:

- Fieldline devices
- Bus cables
- Shielded bus connectors
- Unshielded connectors
- Assembly systems
- Termination resistors
- Other accessories

1.3 Product Description of the Fieldline Stand-Alone Devices

Versions

The Fieldline Stand-Alone product group includes digital devices with the following functions:

- DI

Digital input devices acquire digital control signals from the process level. These signals are transferred to the higher-level automation equipment via the bus. The signal status is indicated on the Fieldline Stand-Alone device using LEDs. Sensors are connected via screw-cage M12 connectors. The sensors are supplied from the sensor voltage U_S .

- DO

Digital output devices transfer the digital control signals from the automation equipment to the process level on to the actuators. The specified load currents for the outputs of various devices can be found in the data sheet. The signal status is indicated on the Fieldline Stand-Alone device using LEDs. Actuators are connected via screw-cage M12 connectors. The outputs are protected against short circuits and overloads. The actuators are supplied from the actuator voltage U_A .

When using the devices in a safety application, the information given in the AH EN FLS FLM SAFE application note must be strictly observed.

- DIO

Digital I/O devices have digital inputs and digital outputs with the same properties as on the input and output devices.

- IOL

These devices are provided with I/O link ports for sensors capable of communications in order to dynamically modify the sensor parameters directly using the PLC.

Connections

The bus, I/O devices, and supply are connected via screw-cage M12 connectors. Every Fieldline Stand-Alone device is connected directly to the bus system.

Degree of protection

The devices have IP65/67 protection.

1.4 Product Description of the Fieldline Modular M12 Devices

Versions

The Fieldline Modular M12 product group includes bus couplers as well as digital and analog devices with the following functions:

BK

The bus coupler provides the transition from the higher-level network to the local bus. It provides the power supply for the local bus devices within a Fieldline Modular station. Local bus devices are the Fieldline Modular I/O devices used to implement a local bus station.

The bus coupler can be connected with up to eight digital sensors using M12 connectors. The slots are double-assigned. The bus coupler supplies the supply voltage for the sensors and reads in the provided signals.

BT BS

The base station receives the I/O data of the Bluetooth I/O devices and integrates them in the process data of the Fieldline Modular local bus.

- DI

Digital input devices acquire digital control signals from the process level. These signals are transferred to the higher-level automation equipment via the bus. The signal status is indicated on the Fieldline Modular device using LEDs. Sensors are connected using screw-cage connectors. The sensors are supplied from the sensor voltage U_S .

- DO

Digital output devices transfer the digital control signals from the automation equipment to the process level on to the actuators. The specified load currents for the outputs of various devices can be found in the data sheet. The signal status is indicated on the Fieldline Modular device using LEDs. Actuators are connected using screw-cage connectors. The outputs are protected against short circuits and overloads. The actuators are supplied from the actuator voltage U_A .

- DIO

Digital I/O devices have digital inputs and digital outputs with the same properties as on the input and output devices.

- AI

Analog input devices acquire analog control signals from the process level. These signals are transferred to the higher-level automation equipment via the bus. Sensors are connected via screw-cage M12 connectors. The sensors are supplied from the sensor voltage U_S .

- AO

Analog output devices transfer the control signals from the automation equipment to the process level on to the actuators. For the specified signal forms of the outputs of various devices, please refer to the device-specific data sheet. Actuators are connected via screw-cage M12 connectors. The outputs are protected against short circuits and overloads. The actuators are supplied from the supply voltage U_S (U_{ANA}).

- RTD

The analog input devices have four inputs for resistive temperature sensors. The measured values are represented by standardized 16-bit values.

- IOL

These devices are provided with I/O link ports for sensors capable of communications in order to dynamically modify the sensor parameters directly using the PLC.

Connection to Inline	The IB IL 24 FLM-PAC branch terminal can be used to connect the Fieldline M12 local bus to the end of an Inline station. This allows for integrating sensors and actuators, which are connected near the station to the Fieldline Modular M12 devices with IP65/67 protection, in an Inline system. Conversion of the physical transmission method of the Inline local bus to the physical transmission method of the Fieldline Modular M21 local bus is performed using the Inline branch terminal. The U_{LS} supply voltage should be supplied separately.
Connections	The bus, I/O devices, and supply are connected using M12 connectors with quick connection method or using radio (local bus only).
Degree of protection	The devices have IP65/67 protection.

1.5 Product Description of the Fieldline Modular M8 Devices

Versions

The Fieldline Modular M8 product range includes digital devices with the following functions:

- DI

Digital input devices acquire digital control signals from the process level. These signals are transferred to the higher-level automation equipment via the bus. The signal status is indicated on the Fieldline Modular device using LEDs. Sensors are connected via screw-cage M8 connectors. The sensors are supplied from the sensor voltage U_S .

- DO

Digital output devices transfer the digital control signals from the automation equipment to the process level on to the actuators. The specified load currents for the outputs of various devices can be found in the data sheet. The signal status is indicated on the Fieldline Modular device using LEDs. Actuators are connected via screw-cage M8 connectors. The outputs are protected against short circuits and overloads. When mounting the device onto a metallic surface, derating does not need to be taken into account. The actuators are supplied from the actuator voltage U_A .

- DIO

On the digital input and digital output devices are four fixed digital inputs and four selectable digital inputs or outputs. Digital I/O devices have digital inputs and digital outputs with the same properties as on the input and output devices. The sensors and actuators are supplied from the actuator voltage U_A .

Connection to Inline

The IB IL 24 FLM-PAC branch terminal can be used to connect the Fieldline M8 local bus to the end of an Inline station. The IB IL 24 FLM MULTI-PAC terminal can be used to connect the FLM local bus several times to an Inline station at any point. This allows for integrating sensors and actuators, which are connected near the station to the Fieldline Modular M8 devices with IP65/67 protection, in an Inline system. Conversion of the physical transmission method of the Inline local bus to the physical transmission method of the Fieldline Modular M8 local bus is performed using the Inline branch terminal.

An segment terminal with fuse (IB IL 24 SEG/F-D) must be used directly before the Inline branch terminal because the M8 system cable also provides the communications and sensor power.

Connection to a Fieldline Modular M12 Station

The FLM APAP M12/M8 adapter can be used to connect the Fieldline M8 local bus to a Fieldline Modular M12 station. The adapter is used to connect the Fieldline Modular M8 devices to a bus coupler or an I/O devices of the Fieldline Modular M12 system. The adapter is provided with the local bus and the communications and sensor power via M12 connectors. For the M8 system cable the local bus, communications and sensor power are converted to 4-pos. M8 female and male connectors for the incoming and outgoing M8 local bus including the power supply.

Connections

The bus, I/O devices, and supply are connected via M8 connectors.

Degree of protection

The devices have IP65/67 protection.

1.6 For Your Safety

1.6.1 Correct Usage

Fieldline devices are designed for use as specified in this user manual and in the device-specific data sheets.

Always observe the data specified in the user manual and in the data sheets. If the operating instructions and safety notes for configuration, installation, and operation given in the documentation are followed, the devices should not normally present a risk to people or property.

1.6.2 Regulations

During device configuration, installation, startup, and maintenance, the valid safety and accident prevention regulations for the specific application must be observed.

1.6.3 Safety Notes



NOTE:

Avoid polarity reversal of the power supplies, as this may damage the device (see Section "Connecting the Power Supply" on page 4-17).



NOTE:

To ensure IP65/67 protection, cover unused connections with protective caps.



NOTE:

Ground devices to provide immunity to interference (see page 4-6).



NOTE:

Only operate Fieldline devices with a safety extra-low voltage of 30 V, maximum, according to IEC 60950/EN 60950/VDE 0805.

1.7 Using Fieldline Devices in Safety Applications

Fieldline devices with an actuator supply that can be disconnected separately can be used in safety applications.

The supply voltage for the output modules is switched off in a safety-related procedure using a safety switching devices (e.g., PSR safety relay from Phoenix Contact). In this way, the outputs are set to the deenergized state independent of the communications and sensor power.



The ordering data of the Fieldline devices approved for use in safety applications and additional information can be found in the application note AH EN FLS FLM SAFE.

FLS FLM SYS INST UM E

2 Description of the Fieldline Stand-Alone Devices

2.1 Housing Versions for Fieldline Stand-Alone Devices

Independent of the bus system two different housing versions are available for the Fieldline Stand-Alone devices.

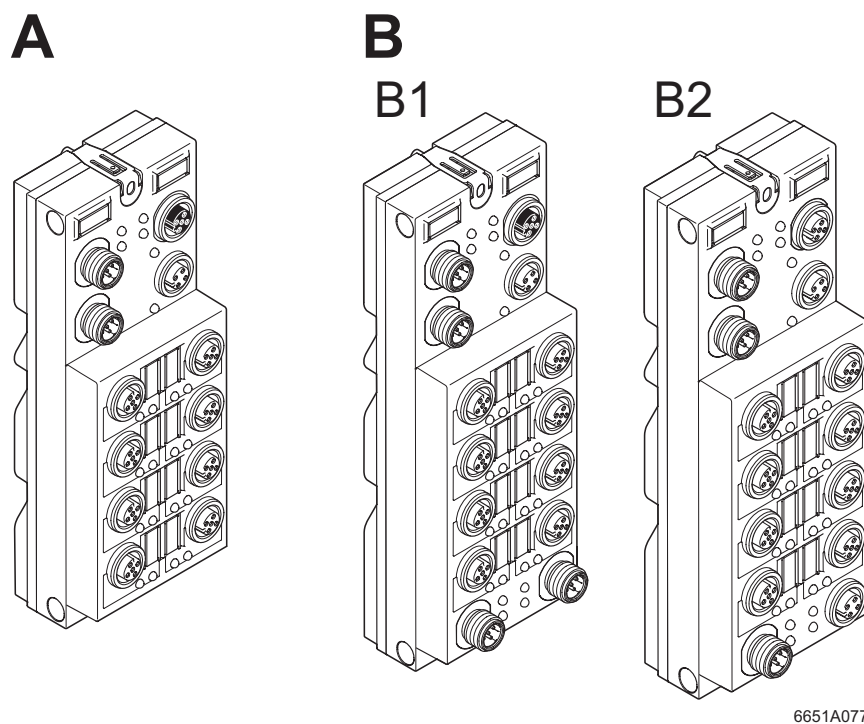
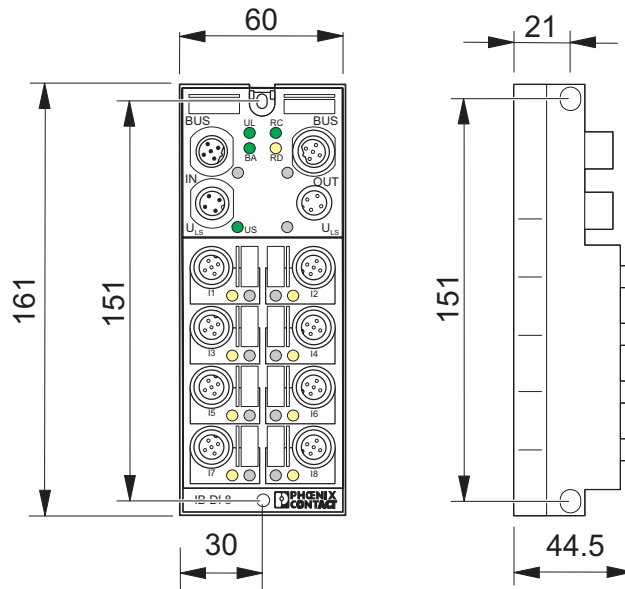

Figure 2-1 Housing versions for the Fieldline Stand-Alone devices

- A** Devices without actuator supply (e.g., digital input device)
- B1** Devices with two connections for the actuator supply (e.g., digital output device)
- B2** Devices with one connection for the incoming supply and one connection to forward the actuator supply (e.g., digital I/O device)

2.2 Housing Dimensions for Fieldline Stand-Alone Devices



6651B010

Figure 2-2 Housing dimensions in mm for FLS devices without actuator supply

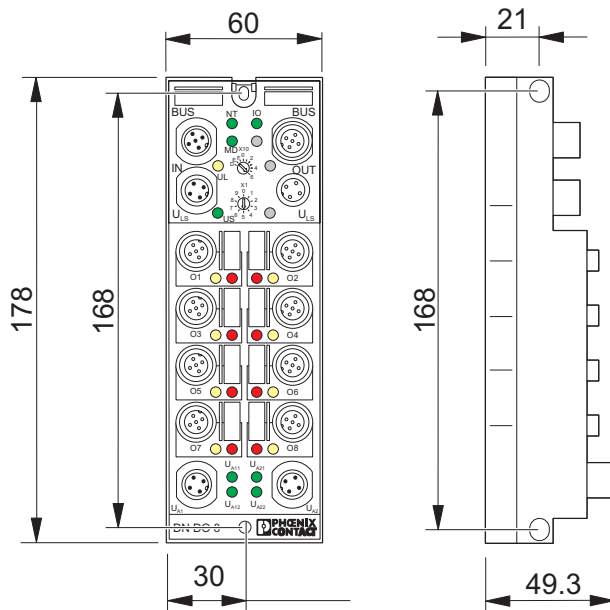

6651B011

Figure 2-3 Housing dimensions in mm for FLS devices with actuator supply

2.3 Basic Structure of the Fieldline Stand-Alone Devices

Figure 2-4 shows the basic structure of the Fieldline Stand-Alone devices. Depending on the bus system and the device function, the device may **not** have all of the elements shown. These elements are marked with an asterisk.

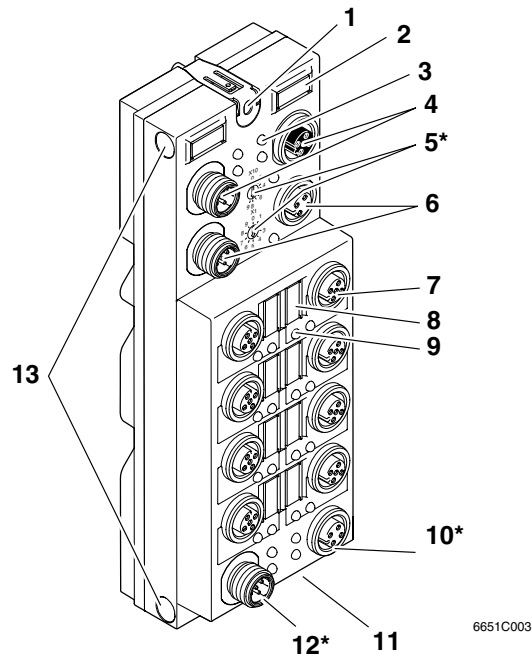

Figure 2-4 Basic structure of the Fieldline Stand-Alone devices

- | | |
|--|--|
| 1 Upper mounting hole (FE connection) | 7 Connections for inputs or outputs |
| 2 Slot for labeling field | 8 Slot for labeling field |
| 3 Diagnostic and status indicators for bus and supply voltages (U_L and U_S) | 9 Status indicator for the inputs/outputs |
| 4 Bus connection (IN and OUT) | 10 Forwarding of actuator supply voltage for DIO devices or connection of actuator supply voltage for DO devices |
| 5 Rotary encoding switch (not for INTERBUS) | 11 Lower mounting hole |
| 6 Connection for the supply voltages for communications power (U_L) and sensors (U_S) (IN and OUT) | 12 Connection for actuator supply voltage (not for DI devices) |
| | 13 Side mounting holes |

2.4 Labeling for Fieldline Stand-Alone Devices

The devices can be labeled above the bus connections (2 in Figure 2-4) and at every I/O connection (8 in Figure 2-4).

Ten labeling fields without color print are supplied as standard with the devices.

When labeling, proceed as follows:

- Complete a labeling field and snap it into the relevant slot.
- If you want to change a labeling field, it can be removed using a small screwdriver.



For professional labeling, Phoenix Contact offers the CMS-MARK-WIN software (see Phoenix Contact CLIPLINE catalog).

2.5 Diagnostic and Status Indicators of the Fieldline Stand-Alone Devices

Diagnostics

Diagnostic indicators (green/red) indicate whether an error is present or not. In the event of an error, they indicate the error type and location. The Fieldline Stand-Alone device is functioning correctly if all the green LEDs are on.

Status

Status indicators (yellow) indicate the signal status of the corresponding input/output. If the yellow status indicators are on, this indicates the signal state "1" of the input/output signal.

Fieldline Stand-Alone devices have three main areas for diagnostic and status indicators. These areas are illustrated in Figure 2-5.

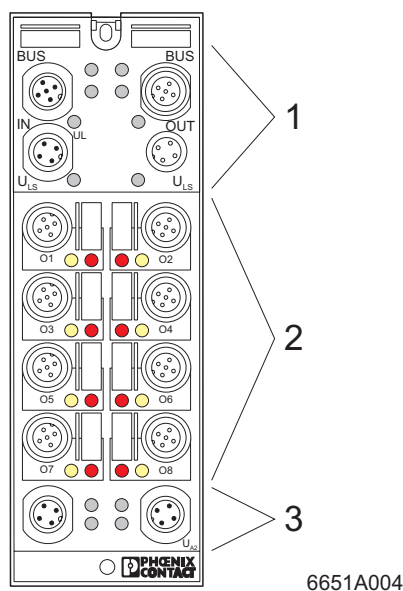

Figure 2-5 Main diagnostic and status indicators for the Fieldline Stand-Alone devices

- 1 Bus-specific indicators
- 2 Inputs and outputs (device-specific)
- 3 Actuator supply (device-specific)



For additional information on the diagnostic and status indicators, please refer to the data sheet for the relevant device.

FLS FLM SYS INST UM E

3 Description of Fieldline Modular Devices

3.1 Housing Versions for Fieldline Modular Devices

Independent of the bus system five different housing versions are available for the Fieldline Modular devices.

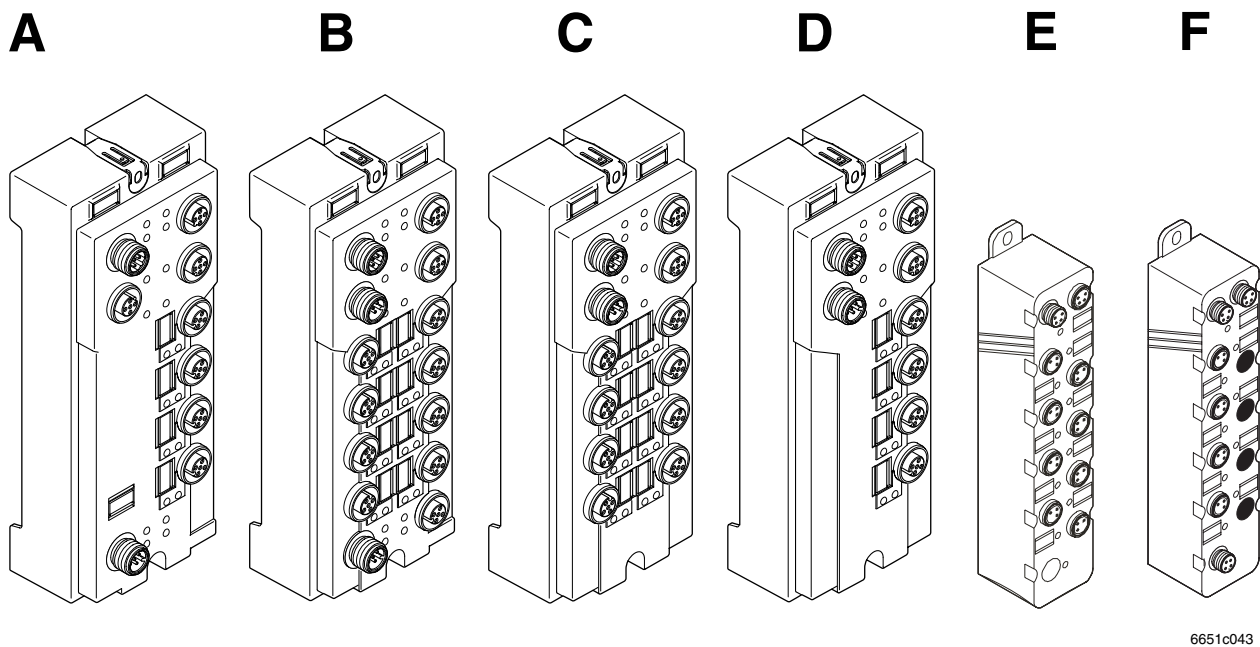

6651c043

Figure 3-1 Housing versions for the Fieldline Modular devices

- A** Bus coupler/base station (BK/BT)
- B** Digital devices (DO/DIO)
- C** Digital devices (DI)
- D** Analog devices (AI/AO)
- E** Digital M8 devices (DI/DIO)
- F** Digital M8 devices (DO)



If not mentioned explicitly, the M12 connection method is used in this manual.

3.2 Housing Dimensions for Fieldline Modular Devices

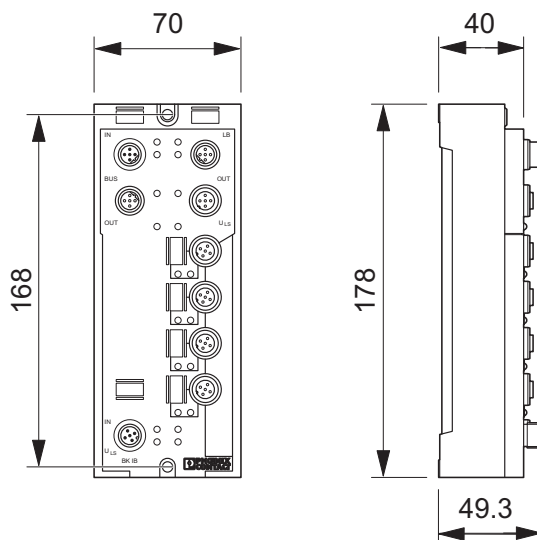

6651B045

Figure 3-2 Housing dimensions in mm for Fieldline Modular devices (M12)

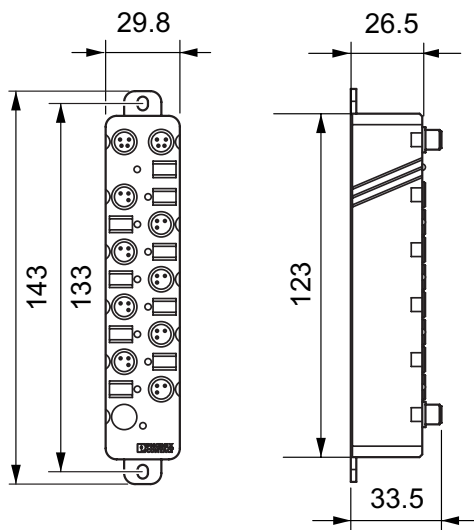

6651A001

Figure 3-3 Housing dimensions in mm for Fieldline Modular devices (M8)

3.3 Basic Structure of the Fieldline Modular Devices

Figure 3-4 to Figure 3-6 show the basic structure of the devices. Depending on the network and the device function, the device may **not** have all of the elements shown. These elements are marked with an asterisk.

3.3.1 Structure of Fieldline Modular Bus Couplers

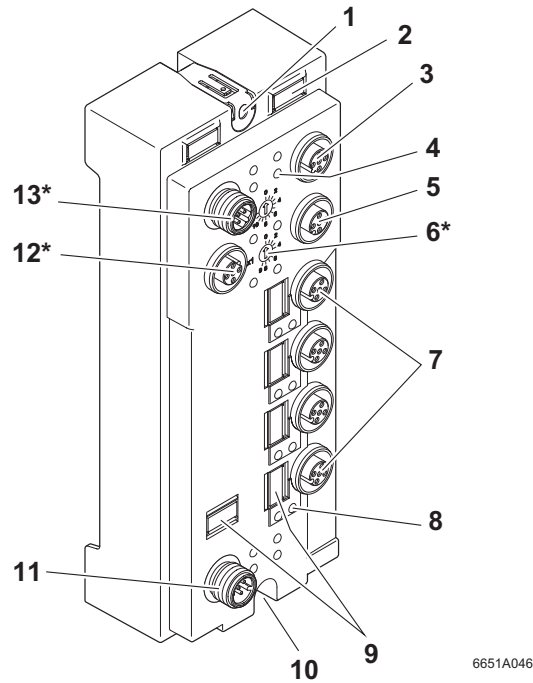

Figure 3-4 Basic structure of Fieldline Modular bus couplers

- | | | | |
|---|---|----|---|
| 1 | Upper mounting hole (FE connection) | 7 | Connections for the inputs |
| 2 | Slot for labeling field | 8 | Status indicator for the inputs |
| 3 | Connection for local bus (LB OUT) | 9 | Slot for labeling fields |
| 4 | Diagnostic and status indicators for bus and supply voltages (U_L and U_S) | 10 | Lower mounting hole |
| 5 | Connection for the supply voltages for communications power and sensors (U_{LS} OUT) | 11 | Connection for the supply voltage (U_{LS} IN) |
| 6 | Rotary encoding switch (not for INTERBUS and Ethernet) | 12 | Connection for the bus (OUT), port 2 for Ethernet |
| | | 13 | Connection for the bus (IN), port 1 for Ethernet |

3.3.2 Structure of the Digital Fieldline Modular Input and Output Devices (M12)

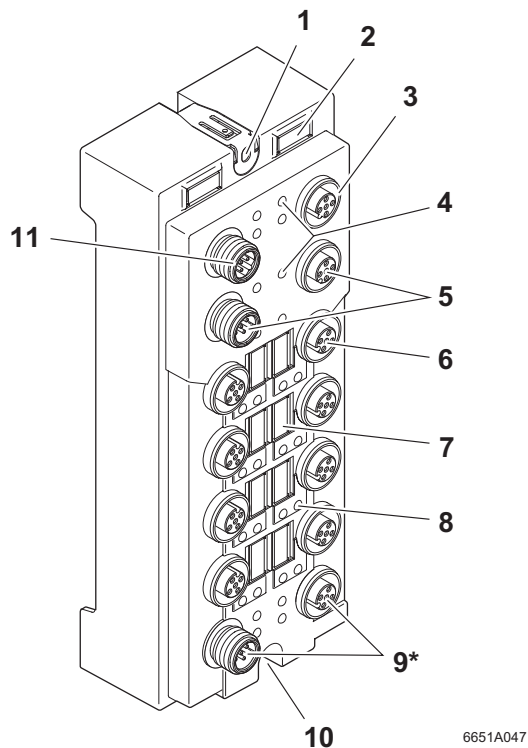

Figure 3-5 Basic structure of the digital Fieldline Modular input and output devices
* see page 3-3

- | | | | |
|---|--|----|---|
| 1 | Upper mounting hole (FE connection) | 7 | Slot for labeling field |
| 2 | Slot for labeling field | 8 | Status indicator for the inputs or outputs |
| 3 | Connection for local bus (LB OUT) | 9 | Connection for the actuator supply voltages (U_A IN and U_A OUT), not for DI devices |
| 4 | Diagnostic and status indicators for bus and supply voltages (U_L and U_S) | 10 | Lower mounting hole |
| 5 | Connection for the supply voltages for communications power and sensors (U_{LS}) | 11 | Connection for local bus (LB IN) |
| 6 | Connections for inputs or outputs | | |

3.3.3 Structure of the Analog Fieldline Modular Input and Output Devices (M12)

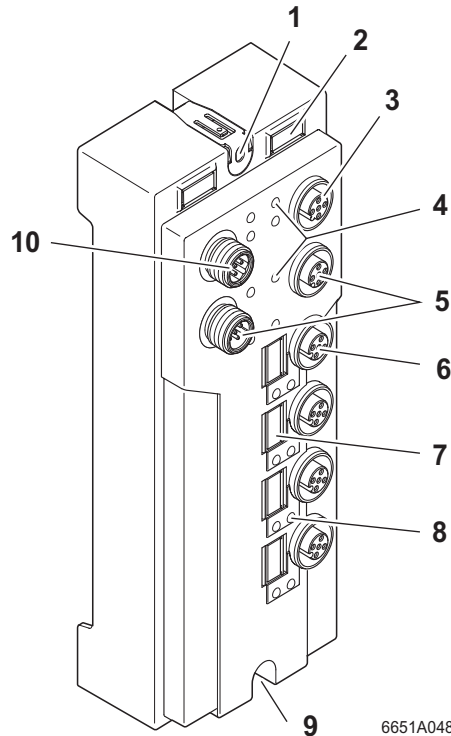

Figure 3-6 Basic structure of the analog Fieldline Modular input and output devices

- | | | | |
|---|--|----|--|
| 1 | Upper mounting hole (FE connection) | 6 | Connections for inputs or outputs |
| 2 | Slot for labeling field | 7 | Slot for labeling field |
| 3 | Local bus (LB OUT) | 8 | Status indicator for the inputs or outputs |
| 4 | Diagnostic and status indicators for bus and supply voltages (U_L and U_S) | 9 | Lower mounting hole |
| 5 | Connection for the supply voltages for communications power and sensors (U_{LS}) and actuators | 10 | Local bus (LB IN) |

3.3.4 Structure of the Fieldline Modular Bluetooth Base Station

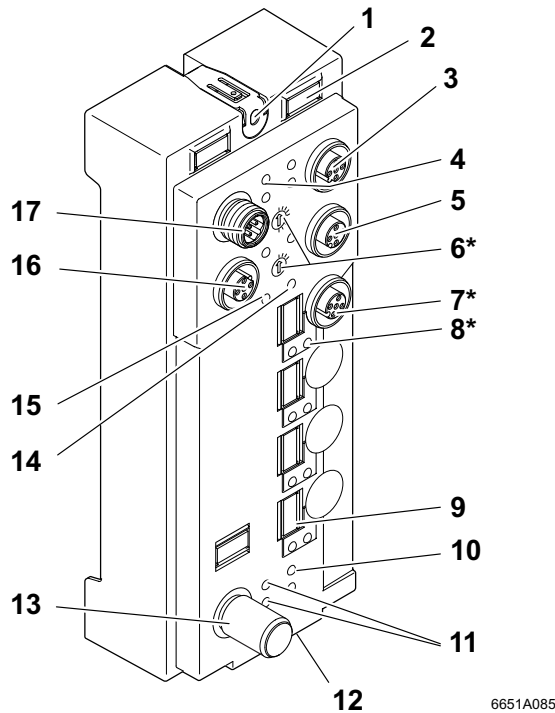

Figure 3-7 Basic structure of the Fieldline Modular Bluetooth base station
* see page 3-3

- | | |
|--|---|
| 1 Upper mounting hole (FE connection) | 9 Slot for labeling field |
| 2 Slot for labeling field | 10 Indicator for wireless connection |
| 3 Connection for local bus (LB OUT) | 11 Indicator for quality of Bluetooth connection (BT) |
| 4 Diagnostic and status indicators for bus and supply voltages (D) | 12 Lower mounting hole |
| 5 Connections for the supply voltages for communications power and sensors (U_{LS} OUT) | 13 Antenna |
| 6 Rotary encoding switch (not for FLM BT BS P2P) | 14 Indicator for transmission speed (2MBD) |
| 7 Programming interface for ID PLUG (not for FLM BT BS P2P) | 15 Indicator for supply voltage (US) |
| 8 Indicator for ID PLUG programming (not for FLM BT BS P2P) | 16 Connection for the supply voltages for communications power and sensors (U_{LS} IN) |
| | 17 Connection for local bus (LB IN) |

3.3.5 Structure of a Digital Fieldline Modular Bluetooth Device

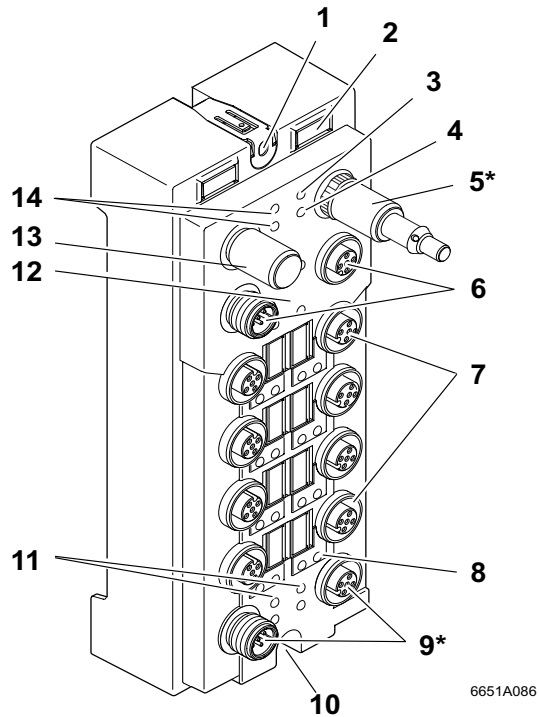
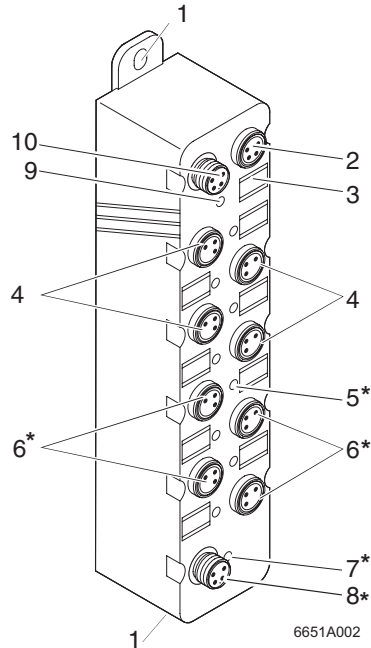

Figure 3-8 Basic structure of a digital Fieldline Modular Bluetooth device
* see page 3-3

- | | |
|---|---|
| 1 Upper mounting hole (FE connection) | 9 Connections for the actuator supply voltage (U_A IN/OUT) |
| 2 Slot for labeling field | 10 Lower mounting hole |
| 3 Indicator for failsafe status (FS) | 11 Indicator for actuator supply (U_A , E_A) |
| 4 Indicator for ID-PLUG status | 12 Diagnostic and status indicators for bus and supply voltages (U_L , U_S , E) |
| 5 ID-PLUG | 13 Antenna |
| 6 Connections for the supply voltages for communications power and sensors (U_{LS} IN/OUT) | 14 Indicator for link quality |
| 7 Connections for inputs or outputs | |
| 8 Status indicator for the inputs or outputs | |

3.3.6 Structure of the Digital Fieldline Modular Input and Output Devices (M8)



15 Basic structure of the digital Fieldline Modular input and output devices (M8),
* see page 3-3

- | | |
|--|--|
| <p>1 Upper and lower mounting latch (FE connection)</p> <p>2 Connection for the local bus (LB OUT) and connection for the supply voltage (U_{LS} OUT)</p> <p>3 Slot for labeling field</p> <p>4 Connections for inputs or outputs</p> <p>5 Status indicator for the inputs/outputs</p> <p>6 Connections for inputs and/or outputs</p> | <p>7 Indicator for the sensor/actuator supply voltage (not for DI devices)</p> <p>8 Connection for the sensor/actuator supply voltage (not for DI modules)</p> <p>9 Indicator for bus diagnostics (D)</p> <p>10 Connection for the local bus (LB IN) and for the supply voltage (U_{LS} IN)</p> |
|--|--|

3.4 Labeling of the Fieldline Modular Devices

When labeling the Fieldline Modular devices, please proceed as for labeling the Fieldline Stand-Alone devices (see page 2-4).

3.5 Diagnostic and Status Indicators of the Fieldline Modular Devices

Diagnostics

The diagnostic indicators (green/yellow/red) indicate whether an error is present or not. In the event of an error, they indicate the error type and location. The Fieldline Modular device is functioning correctly if all the green LEDs are on.

Status indicators

Status indicators (yellow) indicate the signal status of the corresponding input/output. If the yellow status indicators are on, this indicates the signal state "1" of the input/output signal.

Fieldline Modular bus coupler

Fieldline Modular bus couplers have three main areas for diagnostic and status indicators. These areas are illustrated in Figure 3-9.

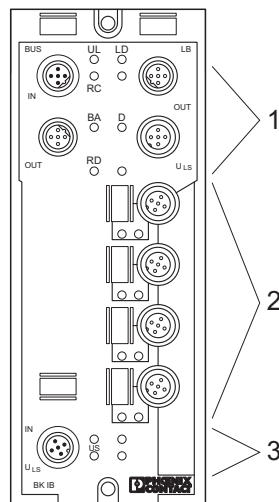

6651A049

Figure 3-9 Main diagnostic and status indicators for the Fieldline Modular bus couplers

- 1 Bus-specific indicators and power supply indicators for additional devices
- 2 Inputs (device-specific)
- 3 Power supply IN (device-specific)



For additional information on the diagnostic and status indicators, please refer to the data sheet for the relevant device.

Digital Fieldline Modular input and output devices, M12 and M8

Digital Fieldline Modular input and output devices have three main areas for diagnostic and status indicators. These areas are illustrated in Figure 3-10.

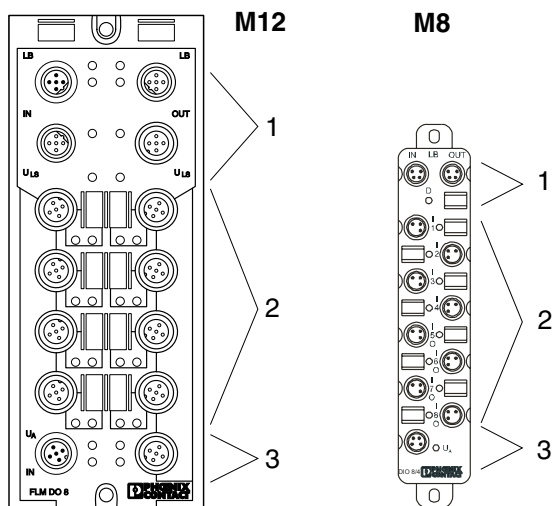

6651B050

Figure 3-10 Main diagnostic and status indicators for the digital Fieldline Modular input and output devices

- 1 Bus-specific indicators and power supply indicators
- 2 Inputs and outputs (device-specific)
- 3 Sensor/actuator supply voltage and error indicator (device-specific)



For additional information on the diagnostic and status indicators, please refer to the data sheet for the relevant device.

Description of Fieldline Modular Devices

Fieldline Modular analog devices

Analog Fieldline Modular devices have two main areas for diagnostic and status indicators. These areas are illustrated in Figure 3-11.

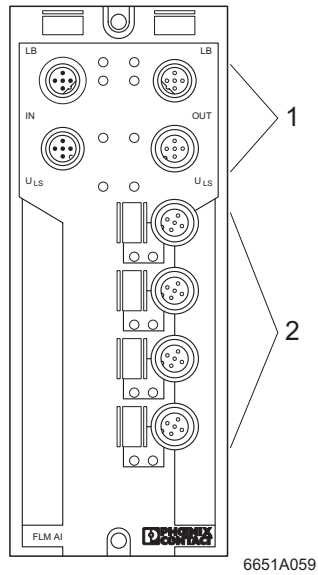

Figure 3-11 Main diagnostic and status indicators for the Fieldline Modular analog devices

- 1 Bus-specific indicators and power supply indicators
- 2 Inputs and outputs (device-specific)



For additional information on the diagnostic and status indicators, please refer to the data sheet for the relevant device.

FLS FLM SYS INST UM E

Fieldline Modular Bluetooth base station

The Fieldline Modular Bluetooth base station has three main areas for diagnostic and status indicators. These areas are illustrated in Figure 3-12.

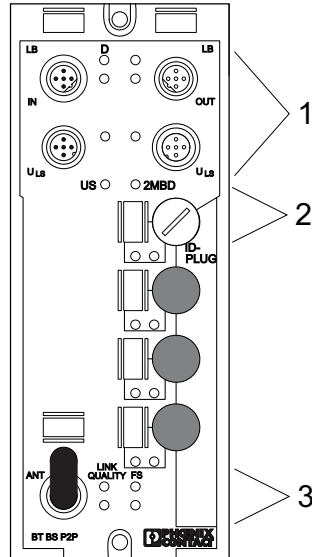

6651A082

Figure 3-12 Main diagnostic and status indicators for the Fieldline Modular Bluetooth base station

- 1 Bus-specific indicators and power supply indicators
- 2 ID PLUG indicators
- 3 Indicator for Bluetooth communication



For additional information on the diagnostic and status indicators, please refer to the data sheet for the relevant device.

Description of Fieldline Modular Devices

Digital Fieldline Modular Bluetooth input and output devices

Digital Fieldline Modular Bluetooth input and output devices have four main areas for diagnostic and status indicators. These areas are illustrated in Figure 3-13.

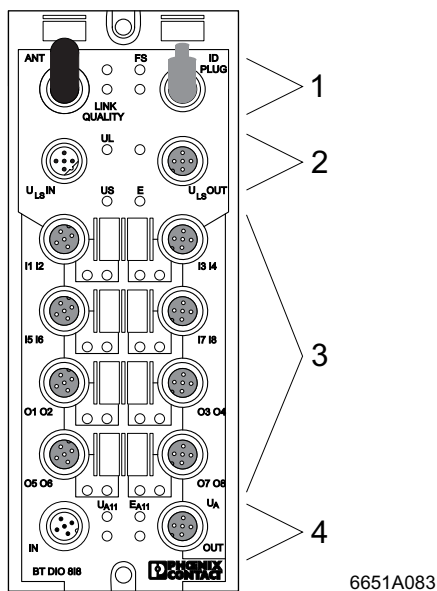

Figure 3-13 Main diagnostic and status indicators for the digital Fieldline Modular Bluetooth input and output devices

- 1 Indicators for Bluetooth communication and ID PLUG
- 2 Power supply indicators
- 3 Inputs and outputs (device-specific)
- 4 Actuator supply and error indicator (device-specific)



For additional information on the diagnostic and status indicators, please refer to the data sheet for the relevant device.

3.6 Structure of a Fieldline Modular Station

The bus coupler opens a powerful local bus, which can be used to connect up to 16 additional devices. The devices used are Fieldline Modular local bus devices for implementing a local bus station. The communications power and sensor voltage supply are also provided via the bus coupler.

The total length of a local bus is 20 m, maximum. The transmission speed can be switched from 500 kbaud to 2 Mbaud.

Using four double-assigned slots the bus coupler can also be connected to up to eight digital sensors via M12 connectors. The bus coupler supplies the sensors with the required voltage and reads the available signals.

Fieldline Modular M12 station

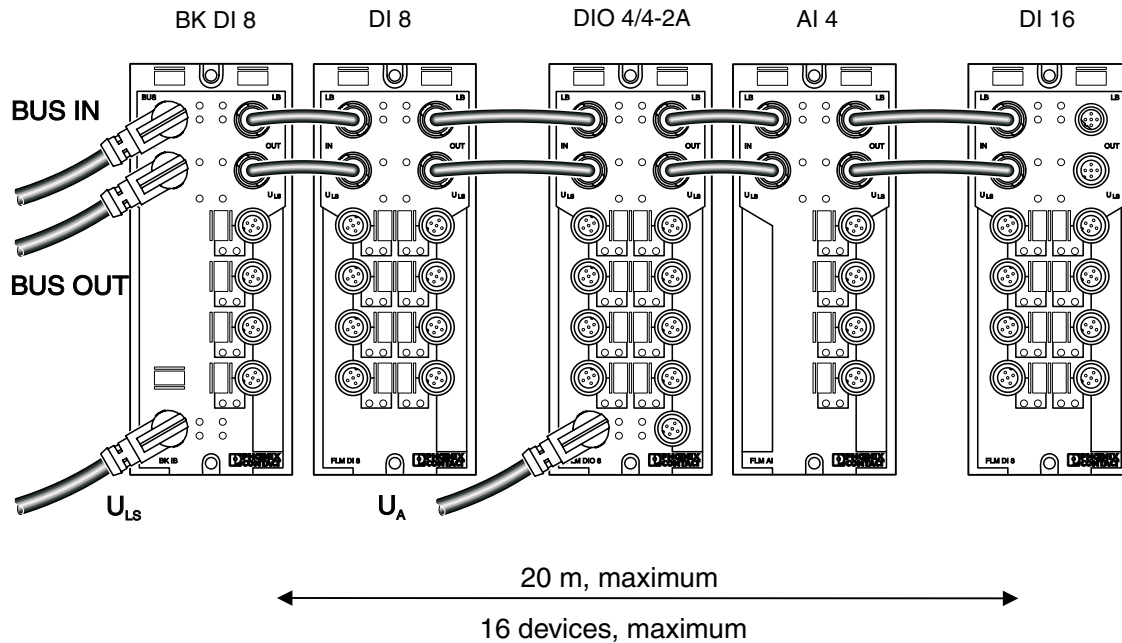

6651B044

Figure 3-14 Example structure of a Fieldline Modular M12 station

The maximum length of the local bus for Fieldline Modular M12 devices is 20 m. A maximum of 16 devices can be connected.

Fieldline Modular M8 station

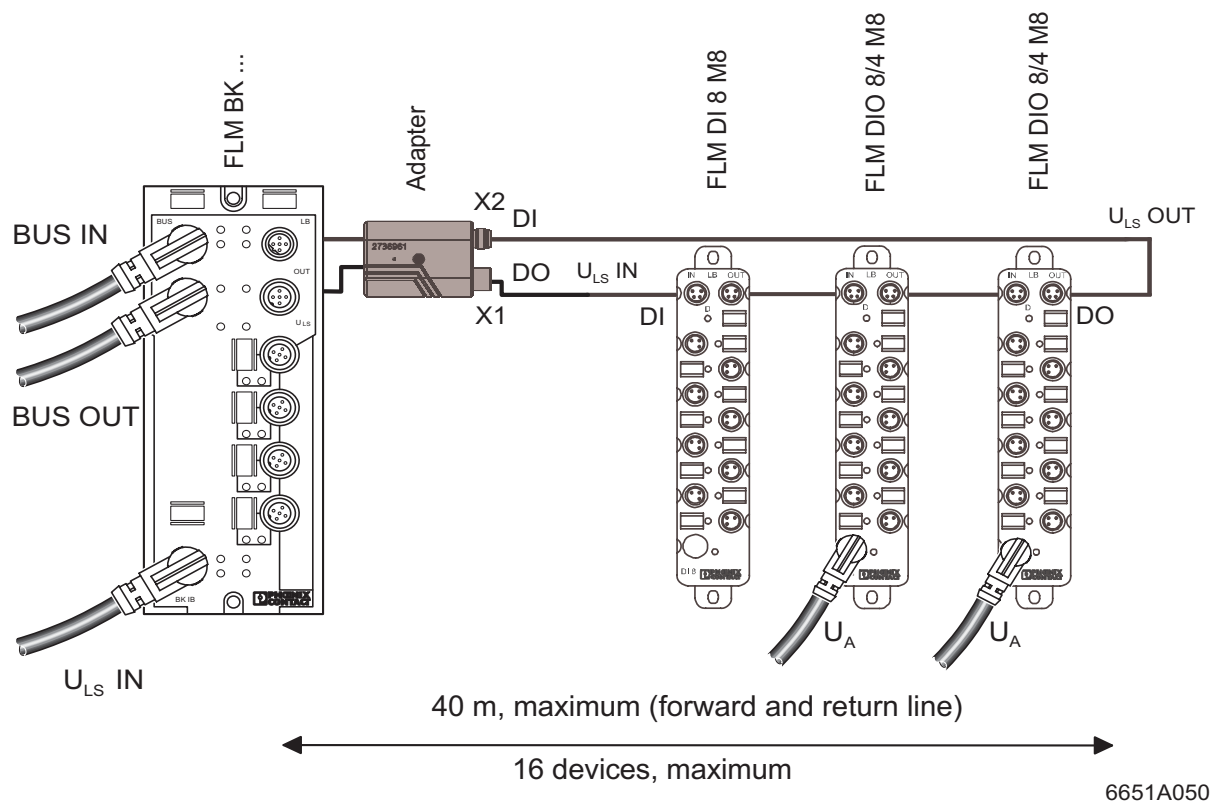

Figure 3-15 Example structure of a Fieldline Modular M8 station

The maximum length of the local bus for Fieldline Modular M8 devices is 40 m. A maximum of 16 devices can be connected. The maximum distance between two M8 devices is 20 m.



Always connect DI to DO.



If U_{LS} is directly supplied to the adapter from the bus coupler, the maximum current load is 2 A. If power is supplied again at an M12 bus device before the adapter, the maximum current load for the M8 bus devices on the local bus is 3 A.

If U_A is supplied in 4-pos. method at an M8 bus device, the maximum current load is 2×3 A.

FLS FLM SYS INST UM E

Fieldline Modular station
(M12/M8, mixed)

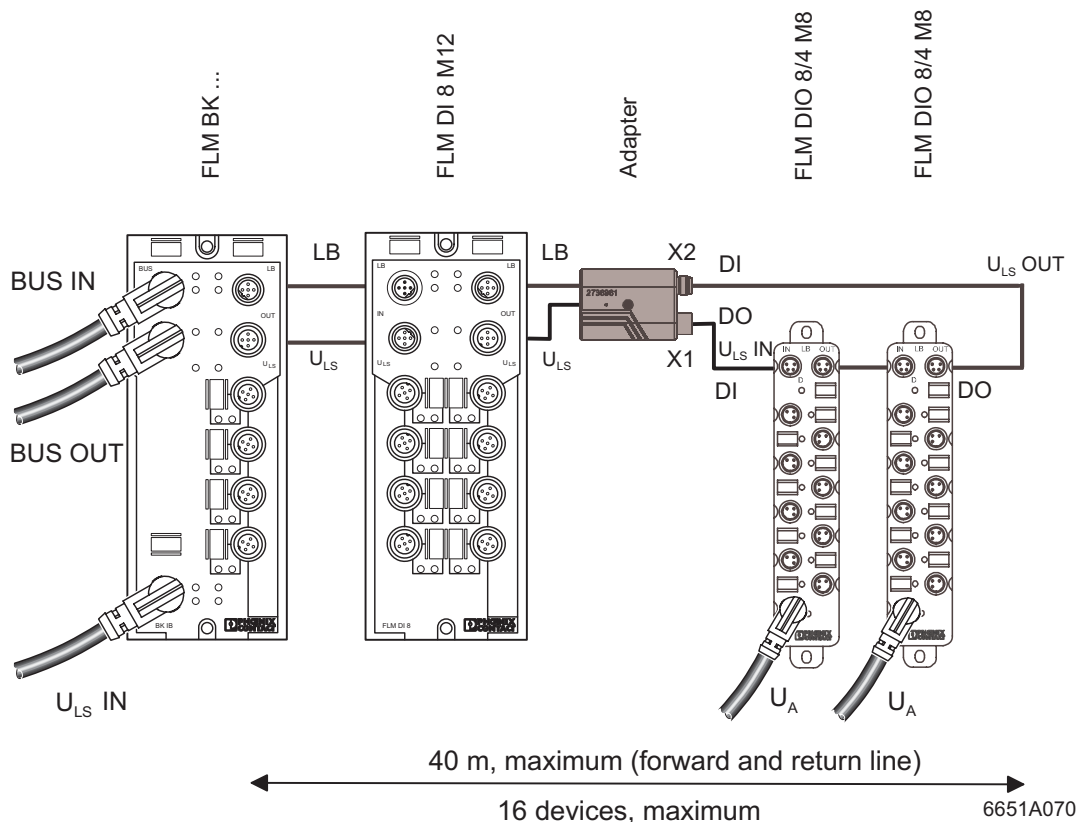

Figure 3-16 Example structure of a Fieldline Modular station (M12/M8, mixed)

The maximum length of the local bus for a station consisting of Fieldline Modular M12 and M8 devices is 40 m. A maximum of 16 devices can be connected. The maximum distance between two M8 devices is 20 m.



Always connect DI to DO.



If U_{LS} is directly supplied to the adapter from the bus coupler, the maximum current load is 2 A. If power is supplied again at an M12 bus device before the adapter, the maximum current load for the M8 bus devices on the local bus is 3 A.

If U_A is supplied in 4-pos. method at an M8 bus device, the maximum current load is 2×3 A.

Description of Fieldline Modular Devices

FLM M8 station connected to Inline using the IB IL 24 FLM MULTI-PAC branch terminal

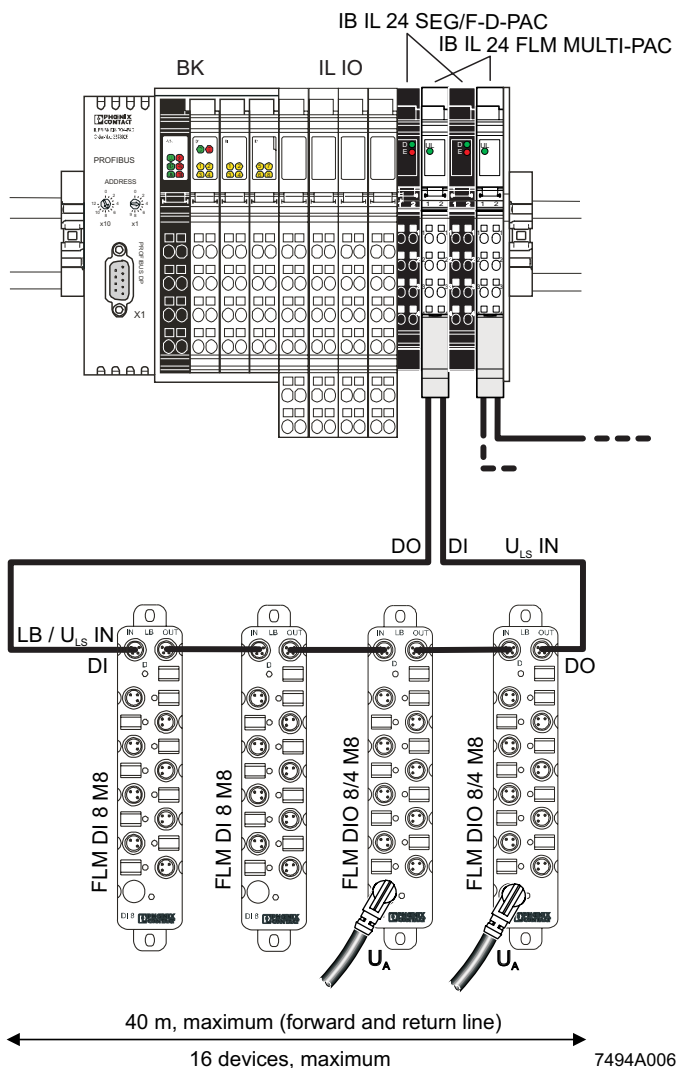

Figure 3-17 Example structure of a Fieldline Modular M8 station connected to Inline

Using the IB IL 24 FLM MULTI-PAC branch terminal it is possible to integrate a Fieldline Modular M8 local bus in the Inline system. When using **one** branch terminal in an Inline station it can be installed at any position. When using **more than one** branch terminals in an Inline station they should be installed at the end of the Inline station.

The **maximum cable length of the Fieldline Modular M8 local bus** is 40 m. The **maximum number of devices of a Fieldline Modular M8 local bus** is 16.

The **maximum number of devices of an Inline station** including the connected Fieldline Modular M8 devices is 63. This number only includes the bus devices (the branch terminal, for example, is not a bus device).

FLS FLM SYS INST UM E



To supply the Fieldline Modular M8 system with power, install a segment terminal with fuse and diagnostics directly before the branch terminal. In this way, the supply voltage for the Fieldline Modular M8 system is guaranteed and diagnostics of the supply voltage is possible.



Always connect DI to DO.



Always supply the U_{LS} supply voltage via U_{LS} IN and U_{LS} OUT from both sides in order for the devices to indicate the error location in the event of a defective local bus cable.



In the event of supplying the U_{LS} power supply from both sides the maximum current load is 2 x 2 A.

Description of Fieldline Modular Devices

**FLM M12 station
connected to Inline using
the IB IL 24 FLM-PAC
branch terminal**

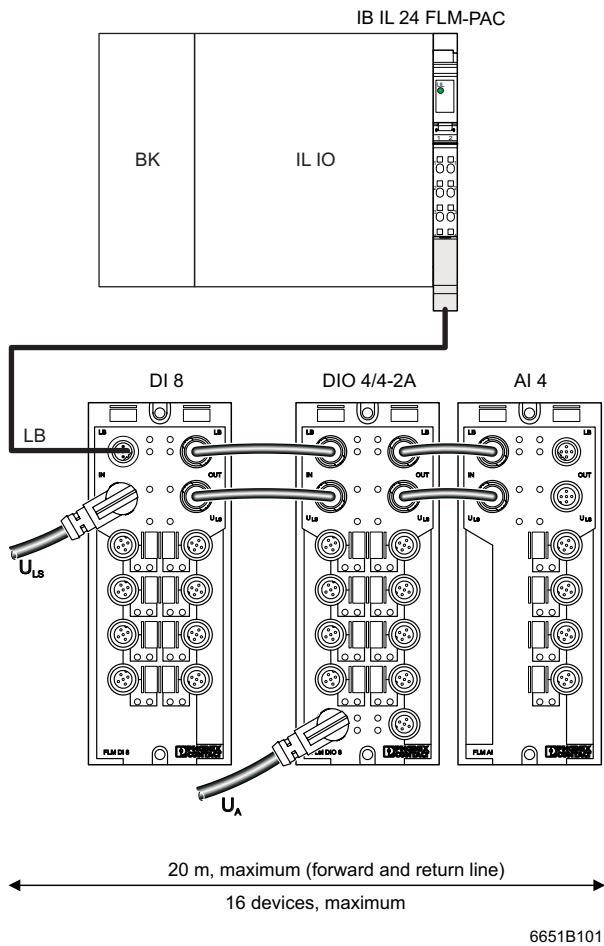

6651B101

Figure 3-18 Example structure of a Fieldline Modular M12 station connected to Inline

Key

- BK Bus coupler
- IL IO Any Inline terminals

Using the IB IL 24 FLM-PAC branch terminal it is possible to integrate a Fieldline Modular M12 or M8 local bus in the Inline system.

**NOTE: Only install the branch terminal as the last terminal in an Inline station.**

The data jumpers for the local bus are **not** available in the position behind the branch terminal. If you snap on terminals in the position behind the branch terminal, the first INTERBUS device behind the branch terminal indicates an interface error (D LED D flashes at 4 Hz). In this case, the Inline station has to be changed in order for the branch terminal to be the last terminal in the station.

The **maximum cable length of the Fieldline Modular M12 local bus** is 20 m. The **maximum cable length of the Fieldline Modular M8 local bus** is 40 m.

The **maximum number of devices of a Fieldline Modular M12 or M8 local bus** is 16.

The **maximum number of devices of an Inline station** including the connected Fieldline Modular devices is 63. This number only includes the bus devices (the branch terminal, for example, is not a bus device).



When installing a Fieldline Modular M8 system, install a segment terminal with fuse and diagnostics directly before the IB IL 24 FLM-PAC branch terminal. In this way, the supply voltage for the Fieldline Modular system is guaranteed and diagnostics of the supply voltage is possible.



When installing a Fieldline Modular M12 system, supply the U_{LS} supply voltage separately at the first FLM device, if possible, in order to use the logic and sensor current of 4 A, maximum, for the FLM station.



In general, the maximum current load of 4 A per contact must not be exceeded.

Description of Fieldline Modular Devices

Fieldline Modular
Bluetooth station (M12)

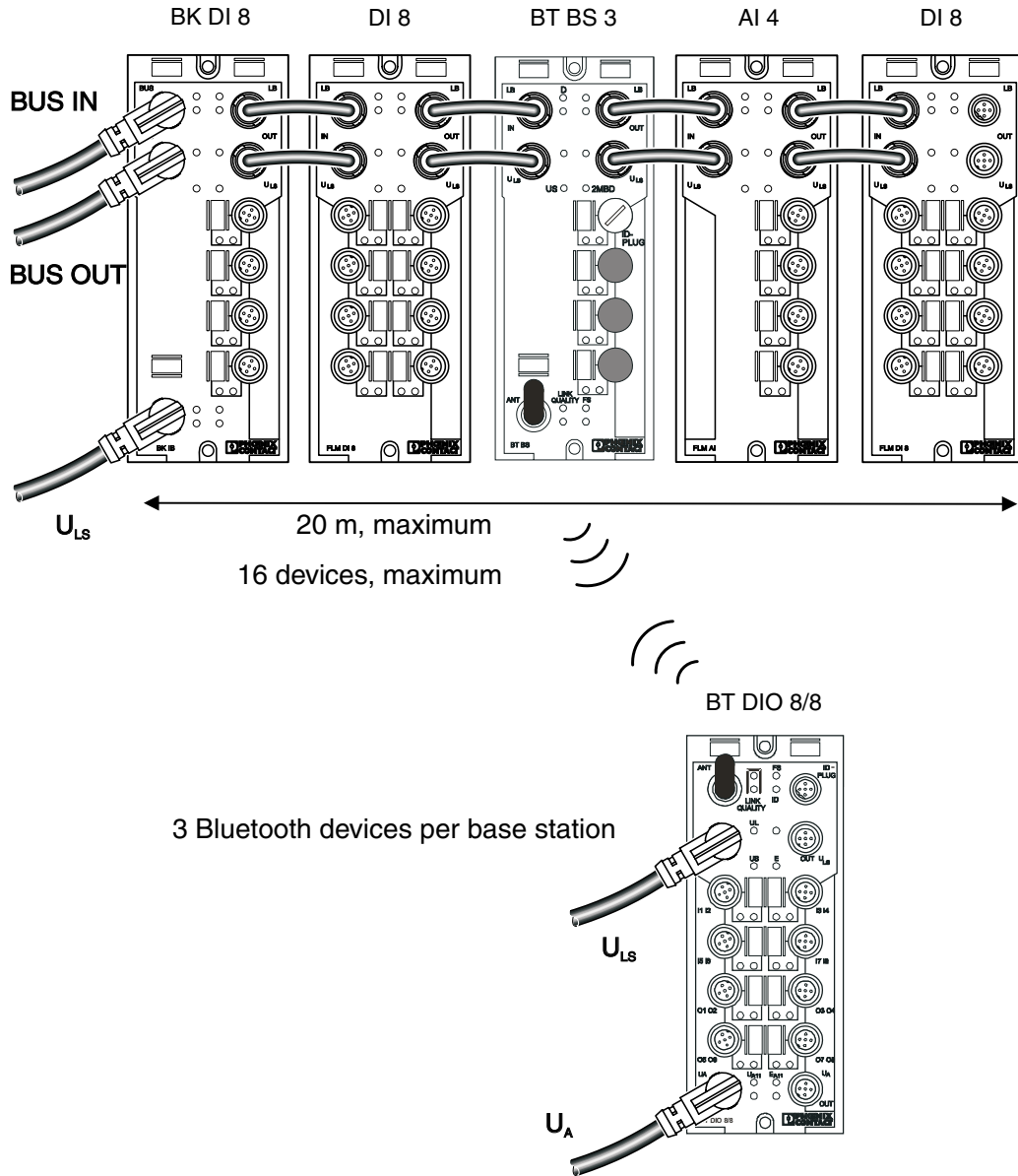

6651B071

Figure 3-19 Example structure of a Fieldline Modular Bluetooth station (M12)



The FLM BT BS 3 M12 device including the Bluetooth I/O devices counts as **one** device on the local bus.

FLS FLM SYS INST UM E

**Fieldline Modular
Bluetooth station (M12)
connected to Inline**

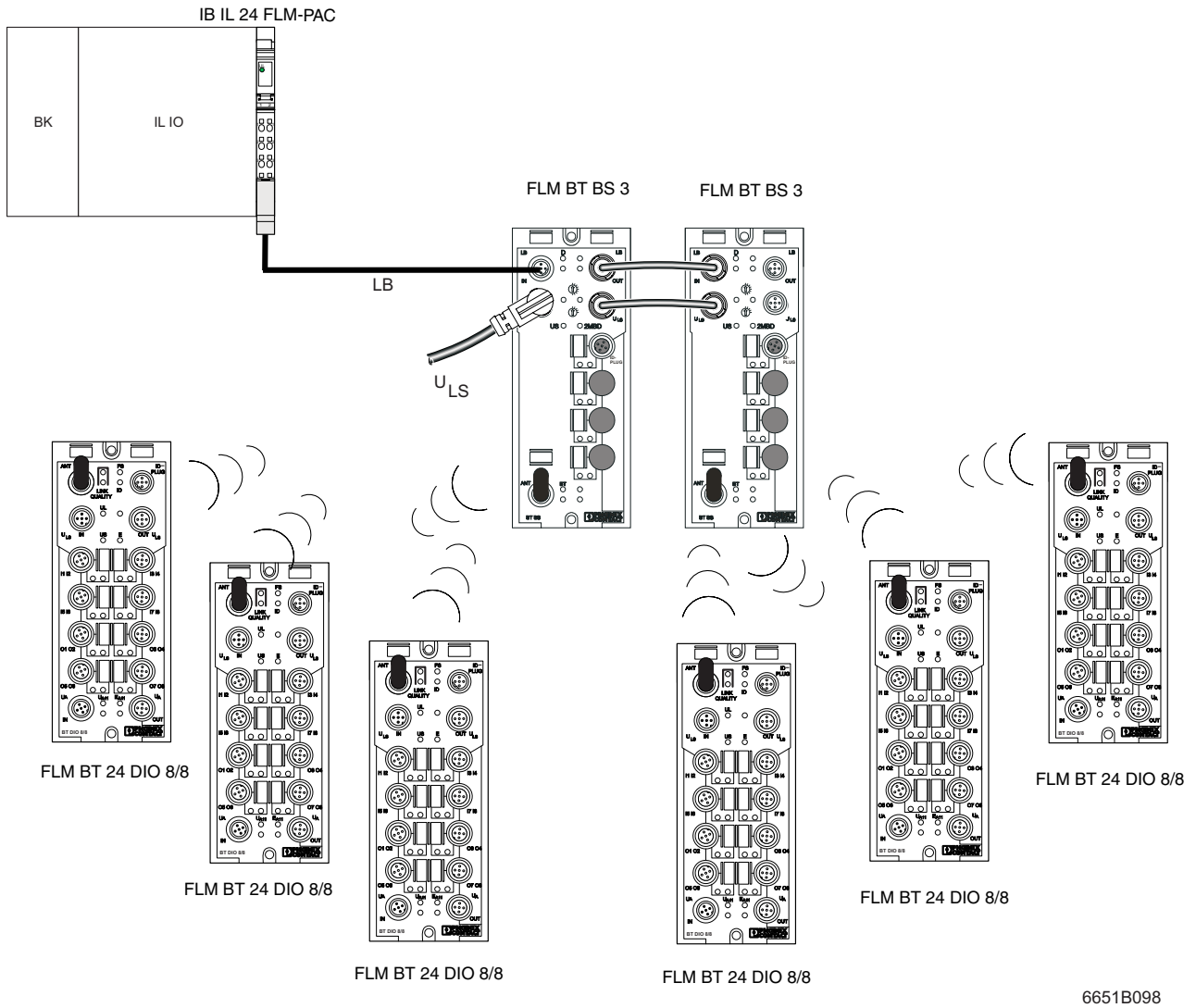

Figure 3-20 Example structure of a Fieldline Modular Bluetooth station (M12) connected to Inline

4 Mounting Fieldline Devices and Connecting Cables

4.1 General Information on Installation

When preparing for cable installation, the local conditions and the corresponding mounting regulations are of major importance. Cables can be installed, for example, in cable ducts or on cable jumpers.



NOTE:

A minimum distance between the cabling and possible sources of interference (e.g., machines, welding equipment, power cables) is defined in the relevant regulations and standards. During system planning and installation, these regulations and standards must be taken into account and observed.



NOTE:

Protect the bus lines from sources of electric/magnetic interference and mechanical strain.



NOTE:

Observe the following regulations for "Electromagnetic Compatibility" (EMC) to keep mechanical risks and interference to a minimum.

Mechanical strain

- Select the correct cable type for each application (e.g., indoor or outdoor installation, flexible drag chains).
- Observe the minimum bending radius.
- Cables must not enter the shear area of moving machine parts.
- Do not install bus lines at right angles to driving paths and machine movements.
- Use cable ducts or cable jumpers.



Observe the specifications for the cable used.

FLS FLM SYS INST UM E

Interference

- Signal and power supply lines should not be installed in parallel. If necessary, metal isolating segments should be placed between the power supply and signal lines.
- Only use connectors with metal housings and connect as much of the shielding as possible to the housing.
- Refer to "Installing Bus Lines Between Buildings" on page 4-3 when grounding outdoor cables running between buildings.
- During installation, all connector interlocks (screws, cap nuts) must be firmly tightened to ensure the best possible contact between shielding and ground. Before initial startup, the connection for the cable ground or shielding must be checked for low-resistance continuity.

Routing of buses in control cabinets

- Install bus lines in separate cable ducts or separate cable bundles.
- Avoid the installation of bus lines parallel to power supply lines.
- Install bus lines with a minimum distance of 10 cm to power cables.

Routing of buses in buildings

- If possible, use metal cable hangers.
- Do not install bus lines together with or parallel to power supply lines.
- Separate bus lines on cable jumpers or in cable ducts from the power supply lines using isolating segments.
- Install bus lines as far away as possible from sources of interference, for example, motors and welding equipment.
- For long line connections, install an additional equipotential bonding line between the connection points.

Routing of buses outside buildings

- Install the bus lines in metal pipes that are grounded on both sides or in concrete cable ducts with continuous reinforcement.
- For long line connections, install an additional equipotential bonding line between the connection points.

Transmission via Bluetooth

- The Bluetooth devices transmit the I/O data via radio.

4.1.1 Installing Bus Lines Between Buildings

Surge voltages

Surge voltages result from switching operations, electrostatic discharges, and lightning discharges. Surge voltages can be coupled inductively, capacitively or galvanically to the electrical lines for power supply, measured value transmission, and data transmission. In this way, surge voltages reach power supply units and the interfaces of systems and termination devices.

Grounding cable shielding

Ground the cable shielding (2 in Figure 4-1) directly after it has been installed in the building to avoid surge voltages. The cable shielding must have a diameter that meets all applicable standards.

Equipotential bonding line

Install an additional equipotential bonding line between the grounding points of buildings (3 in Figure 4-1) that preferably is designed as

- a metal reinforced concrete channel
- an additional grounding cable
- a metal pipe

Surge voltage protection devices

Phoenix Contact recommends that all cable wires are connected to surge voltage protection devices (1 in Figure 4-1) to protect the modules against surge voltages.



For information on the surge voltage protection devices, please refer to the TRABTECH catalog. Observe all national and international regulations when installing surge voltage protection devices.

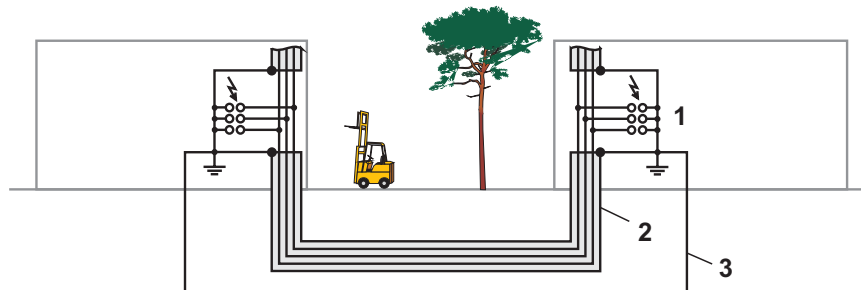

6651A041

Figure 4-1 Surge voltage protection measures

- 1 Surge voltage protection devices
- 2 Cable shielding
- 3 Equipotential bonding line

4.1.2 Interference Suppression Measures

Phoenix Contact recommends connecting relay coils or motor coils with an RC element to protect the devices against interference. Depending on the application, the delay time of the relay can be increased by approximately 1 ms.

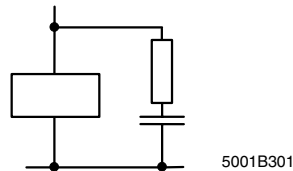

Figure 4-2 Relay coil with RC element

When sizing the RC element, the following values are recommended: $R = 100 \Omega$ to 200Ω ; $C = 220 \text{ nF}$ to 470 nF .

4.1.3 Grounding Concept



WARNING:

Grounding protects people and machines against hazardous voltages. To avoid these hazards, correct grounding, taking the local conditions into account, is vital. Ensure that the devices you are using are properly grounded before startup.

Fieldline devices operate in the low-level signal voltage range. In low-level signal devices, interference is discharged via functional earth ground (FE).

Functional Earth Ground Connection for Fieldline Devices

Fieldline devices are designed for screw-mounting on a flat mounting surface (direct mounting). FE connection for the housing can be achieved using a mounting screw on a grounded mounting surface or an external grounding connection (latch) (see Section "Mounting Fieldline Stand-Alone Devices" on page 4-6 and Section "Mounting Fieldline Modular Devices" on page 4-10).

4.2 Installation Instructions

**NOTE: Electrostatic discharge!**

The device contains components that can be damaged or destroyed by electrostatic discharge. When handling the device, observe the necessary safety precautions against electrostatic discharge (ESD), in accordance with EN 61340-5-1 and EN 61340-5-2, as well as IEC 61340-5-1 and IEC 61340-5-2.

**NOTE:**

Only qualified personnel should mount and remove a device while observing the ESD regulations.

**NOTE: Meet noise immunity requirements**

Connect functional earth ground as described in "Mounting Fieldline Stand-Alone Devices" on page 4-6 and "Mounting Fieldline Modular Devices" on page 4-10.

**NOTE: Ensure IP65/67 protection**

To ensure IP65/67 protection, cover unused connections with protective caps.

**NOTE: Avoid damage to the electronics**

Only supply the sensors with the voltage U_S provided at the connection points.

**NOTE: Avoid polarity reversal**

Avoid polarity reversal of the supply voltages U_L , U_S , and U_A .

4.3 Mounting Distances

No specific distances are required between devices or from a device to a cabinet door or cover. Mounting distances are determined solely by the connectors used and the bending radii of the cables.

4.4 Mounting Fieldline Stand-Alone Devices

There are two options for mounting Fieldline Stand-Alone devices:

- Direct mounting on the front on a flat mounting surface
- Direct mounting on the side on a flat mounting surface



NOTE:

The mounting surface must be flat to avoid strain in the housing when tightening the screws.

Functional earth grounding



NOTE:

Functional earth grounding is absolutely essential for error-free bus operation.

For direct mounting on the front on a grounded mounting surface, the devices are grounded using the upper mounting screw (see Figure 4-4).

For side mounting and for front mounting on an ungrounded mounting surface, the devices are grounded using cable lugs (2.8 mm) via the external grounding connection (connection latch), see page 4-8 and page 4-9.

Mounting

You can directly mount the devices on the mounting surface or on mounting profiles using two mounting holes (\varnothing 4 mm, cylindrical sinking 8 mm). Please refer to the dimensional drawings in Section "Housing Dimensions for Fieldline Stand-Alone Devices" on page 2-2 for the drill hole distance.

The mounting materials required are two screws with a diameter of 4 mm (M4) and a maximum head diameter of 7 mm and two retaining washers. The length of the screws depends on the mounting method used (at least 30 mm for front mounting, at least 40 mm for side mounting).

The tightening torque is 2.8 Nm.

4.4.1 Front Mounting for Fieldline Stand-Alone Devices

- Screw the device directly onto the flat mounting surface using two mounting screws (1 and 2 in Figure 4-3).

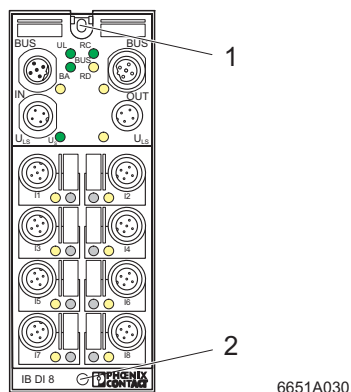

Figure 4-3 Front mounting (FLS)

Grounded mounting surface

If the mounting surface is grounded, the device is connected to functional earth ground via the upper mounting screw (Figure 4-4).

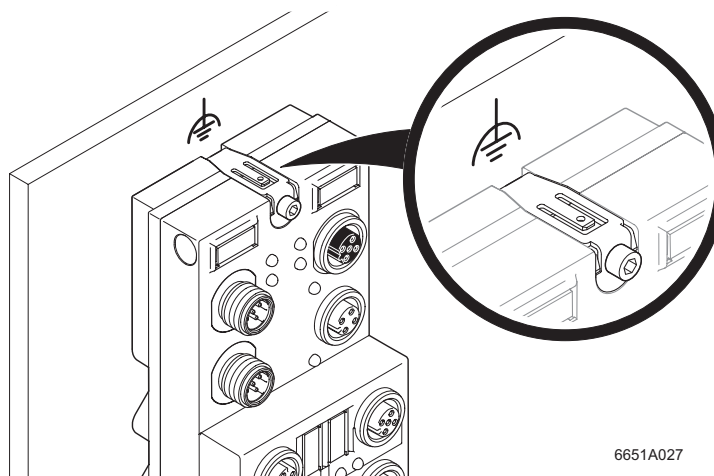

Figure 4-4 Functional earth grounding with grounded mounting surface (FLS)

FLS FLM SYS INST UM E**Ungrounded mounting surface**

If the mounting surface is not grounded, the device must be grounded via the external FE connection.

To connect functional earth ground, proceed as shown in Figure 4-5:

- Bend the connection latch back (1).
- Insert a cable lug (2.8 mm), which is connected to FE, in this connection (2).

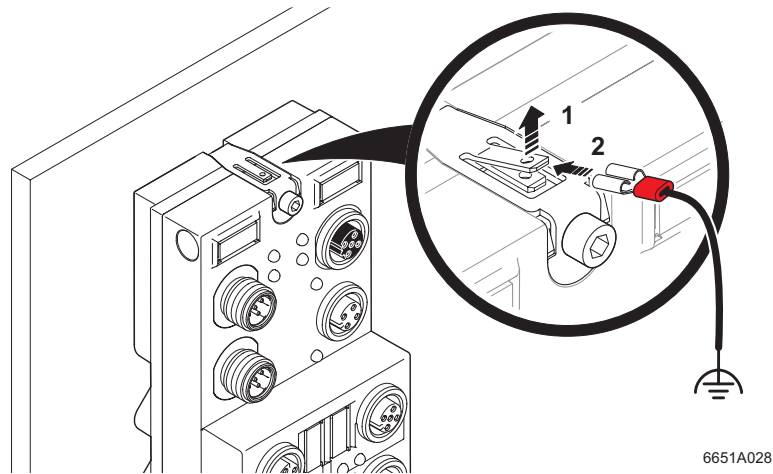

Figure 4-5 Functional earth grounding via external FE connection for front mounting (FLS)

4.4.2 Side Mounting for Fieldline Stand-Alone Devices

- Screw the device onto the mounting surface using two mounting screws in the side mounting holes (1 and 2 in Figure 4-6).

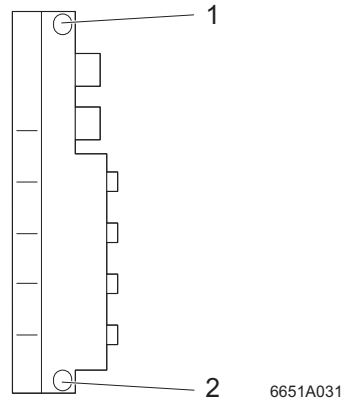

Figure 4-6 Side mounting (FLS)

As in this case the mounting screws have no contact with FE, the device must be grounded via the external FE connection.

To connect functional earth ground, proceed as shown in Figure 4-7:

- Bend the connection latch back (1).
- Insert a cable lug (2.8 mm), which is connected to FE, in this connection (2).

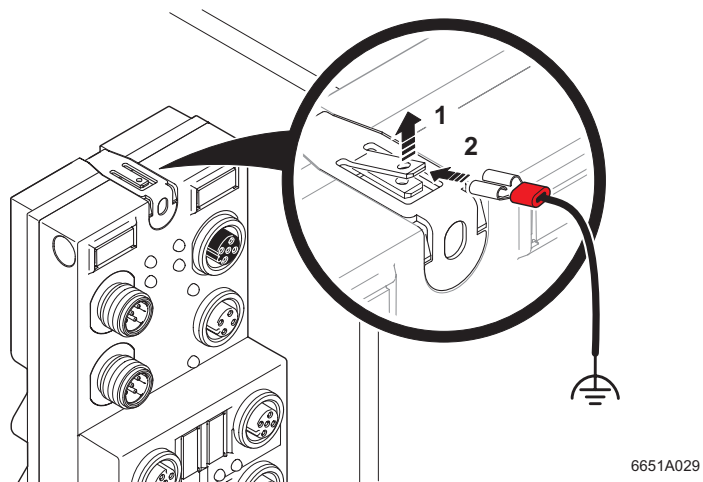

Figure 4-7 Functional earth grounding via external FE connection for side mounting (FLS)

4.5 Mounting Fieldline Modular Devices

There are two options for mounting Fieldline Modular devices:

- Direct mounting on the front on a flat mounting surface (M8 or M12)
- Mounting the devices side by side on a mounting plate (M12 only)

4.5.1 Direct Mounting on a Flat Mounting Surface



NOTE:

The mounting surface must be flat to avoid strain in the housing when tightening the screws. Do not use this device to bridge gaps in order to prevent forces to be transmitted onto the device.

Functional earth grounding



NOTE:

Functional earth grounding is absolutely essential for error-free bus operation.

For direct mounting on the front on a grounded mounting surface, the devices are grounded using the upper mounting screw (see Figure 4-8).

For front mounting on an ungrounded mounting surface, the devices are grounded using cable lugs (2.8 mm) via the external grounding connection (connection latch), see Figure 4-10.

Mounting

You can directly mount the devices on the mounting surface, using two mounting holes (\varnothing 4 mm, cylindrical sinking 8 mm). Please refer to the dimensional drawings in Section "Housing Dimensions for Fieldline Modular Devices" on page 3-2 for the drill hole distance.



For Fieldline Modular M8 devices tighten the fixing screws at the girder metal sheet with a maximum of 2.8 Nm.

Mounting Fieldline Devices and Connecting Cables

Screw the device directly onto the mounting surface using two mounting screws (1 and 2 in Figure 4-8).

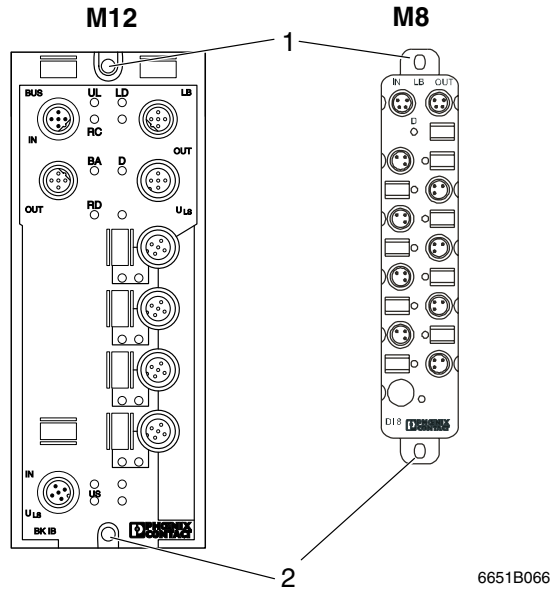

Figure 4-8 Front mounting (FLM)

Grounded mounting surface, FLM M12

If the mounting surface is grounded, the device is connected to functional earth ground via the upper mounting screw (Figure 4-9).

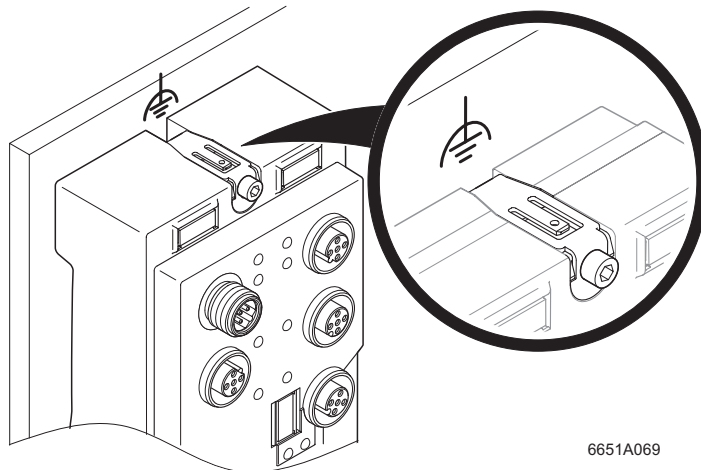

Figure 4-9 Functional earth grounding with grounded mounting surface (FLM M12)

FLS FLM SYS INST UM E

Ungrounded mounting surface, FLM M12

If the mounting surface is not grounded, the device must be grounded via the external FE connection.

To connect functional earth ground, proceed as shown in Figure 4-10:

- Bend the connection latch back (1).
- Insert a cable lug (2.8 mm), which is connected to FE, in this connection (2).

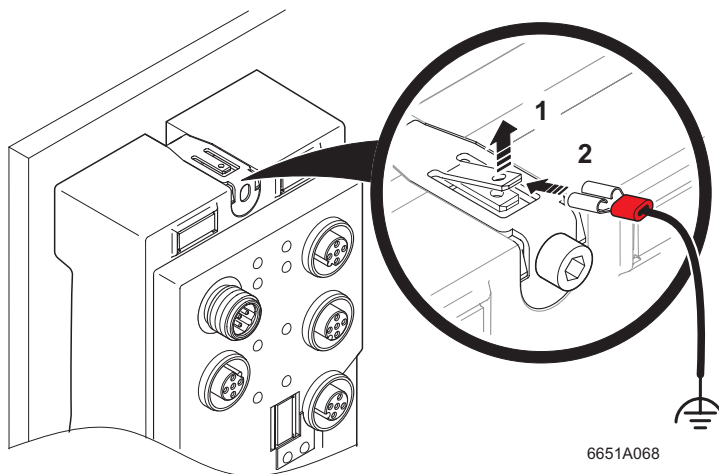

Figure 4-10 Functional earth grounding via external FE connection (FLM M12)

Grounded mounting surface, FLM M8

When mounting the devices bottom on a conductive surface, the device is connected to functional earth ground via the mounting screw.

Ungrounded mounting surface, FLM M8

When mounting the devices bottom on a non-conductive surface, the device is connected to functional earth ground using the mounting screw via a cable lug.

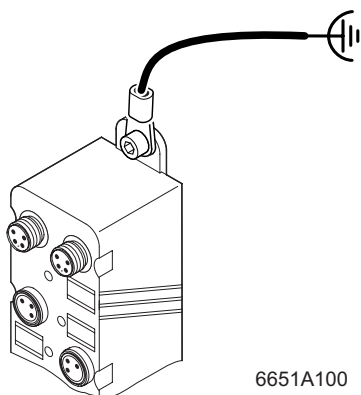

Figure 4-11 Functional earth grounding using a mounting screw via a cable lug (FLM M8)

4.5.2 Mounting on a Mounting Plate



For mounting Fieldline Modular M12 devices Phoenix Contact recommends using a mounting plate. The FLM MP5 mounting plate (Order No. 2736660) can be used to mount up to five devices. The FLM MP7 mounting plate (Order No. 2736673) supports up to seven devices.

Mounting

You can directly mount the devices on the mounting plate using two mounting holes (\varnothing 4 mm, cylindrical sinking 8 mm). The device is connected to functional earth ground via the upper mounting screw, see Figure 4-9 on page 4-11.



Use standard M4 x 40 mm screws. The torque is 2.8 Nm.

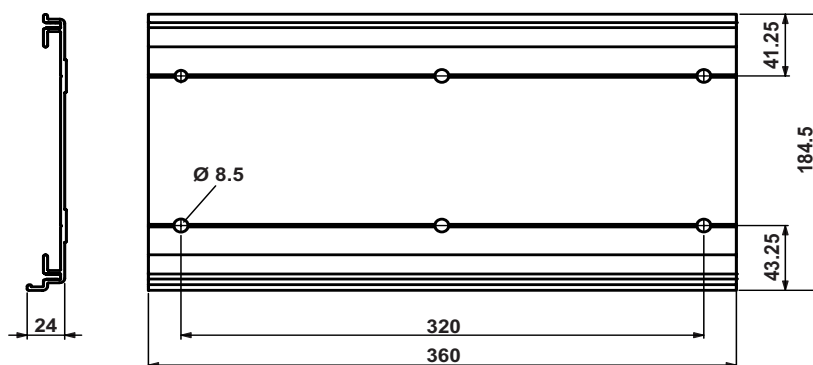

6651a0074

Figure 4-12 Dimensional drawing for FLM MP5 mounting plate (mm)

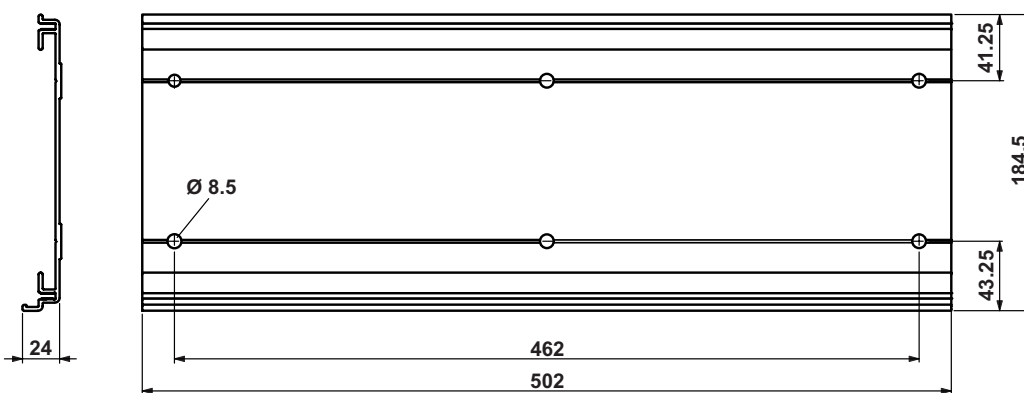

6651a0075

Figure 4-13 Dimensional drawing for FLM MP7 mounting plate (mm)

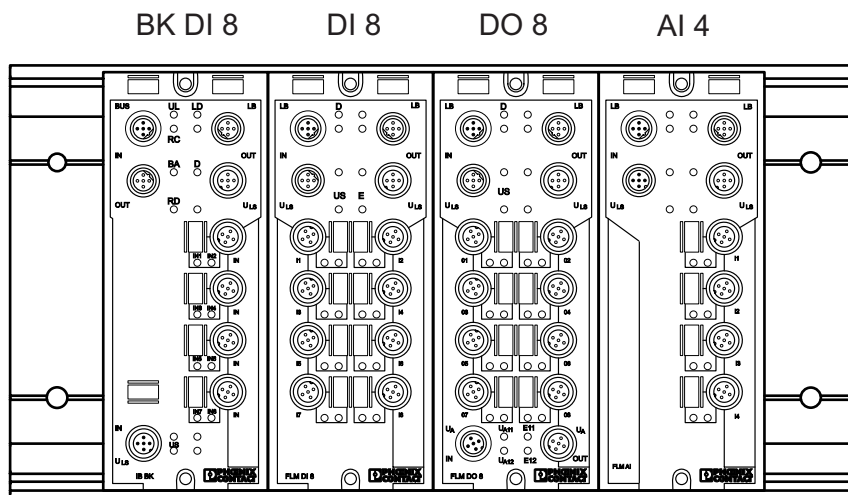

6651B076

Figure 4-14 Fieldline Modular M12 devices on an FLM MP5 mounting plate

4.6 Setting the Address and Transmission Speed for Fieldline Devices

PROFIBUS-DP, DeviceNet™, CANopen

Fieldline devices for **PROFIBUS-DP**, **DeviceNet™**, and **CANopen** bus systems have rotary encoding switches for setting the address and, if necessary, the transmission speed (see user manual for the relevant bus system). Rotary encoding switch X10 is used to specify the tens and switch X1 is used to specify the units of the device ID (module ID).

Example:

Setting address 46 (e.g., PROFIBUS-DP):

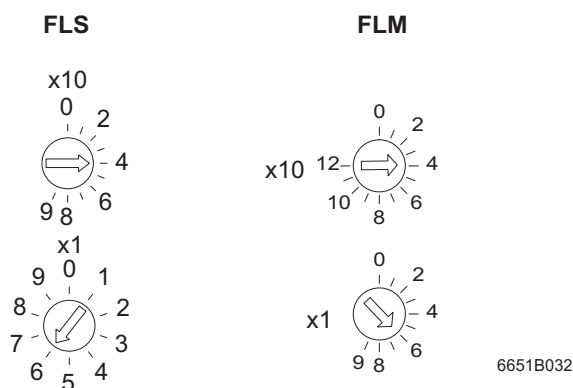

Figure 4-15 Example: address 46 (FLS and FLM BK)



Adjust the rotary encoding switches using a suitable screwdriver (according to DIN 5264: blade width 3.0 mm or 2.5 mm). Use of an unsuitable tool may damage the rotary encoding switches.



For additional information on addresses and transmission speeds, please refer to the Fieldline user manual for your bus system and the device-specific data sheet.

FLS FLM SYS INST UM E

Bluetooth

The device address is set using rotary encoding switches on the base station. The ID-PLUG is programmed using the base station. If the ID-PLUG is plugged on the base station, the device address is read by the rotary encoding switch and, together with the connection parameters, written to the ID-PLUG. The ID-PLUG stores the connection parameters (Bluetooth address of the base station and pass key) and the device address. During programming the ID-PLUG LED is yellow. After successful programming the ID-PLUG is green.

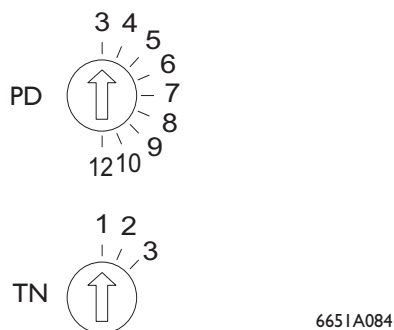

Figure 4-16 Rotary encoding switch on the FLM BT BS 3 device



For further information on setting up an FLM BT BS 3 local bus device, please refer to the device-specific data sheet.

4.7 Connecting the Power Supply

For Fieldline devices, a distinction is made between three different voltages:

- U_L to supply the communications power for the device electronics (always required)
- U_S to supply the sensors (only required for devices with inputs)
- U_A to supply the actuators (only required for devices with outputs)



With Fieldline Modular M8 DIO devices U_A also supplies the sensors.

Connection

All supply voltages are connected via M8 or M12 connectors.

Current carrying capacity



NOTE:

Connect each of the supply voltages completely (to +24 V and GND). Do not connect several supply voltages via one GND, as this exceeds the current carrying capacity of the contacts.

4.7.1 Power Supplies U_L and U_S

The voltages U_L and U_S are supplied via the U_{LS} IN connection.

The power supply U_L is required to supply the communications power for the device electronics. It must be connected to every device. If this supply voltage is disconnected, the device does not function.

Install the power supply for the device electronics independently of the power supply for the actuators. Protect the power supplies independently. In this way the bus continues to run even if some I/O devices are switched off.

The power supply U_S supplies the sensors. It is only connected to devices with inputs and is supplied at the U_{LS} connection.

For **INTERBUS**, **PROFIBUS-DP** and **Ethernet**, the voltages U_L and U_S are supplied via the U_{LS} IN connection and, if other devices are also to be supplied, forwarded via U_{LS} OUT.

For **DeviceNet™**, the voltage U_L is always transferred via the bus cable and supplied at the BUS IN connection via V+/V- and then forwarded via BUS OUT.

For **CANopen**, the voltage CAN U_L is transferred via the bus cable and supplied at the BUS IN connection via V+/V- and then forwarded via BUS OUT.

For Fieldline Modular devices, the voltage U_L for the bus coupler is supplied at the U_{LS} connection.

For information on using the communications power for other bus systems, please refer to the device-specific data sheets

FLS FLM SYS INST UM E

Power supply U_{LS} for Fieldline Stand-Alone devices

Connect the power supplies for the communications power and the sensors U_{LS} to female connector U_{LS} IN. To supply other devices, connect the cable for the outgoing supply voltage to female connector U_{LS} OUT.



NOTE:

The current carrying capacity of the M12 connectors is 4 A per contact. Ensure that this value is not exceeded. Please note that the connection for the outgoing supply voltage is not monitored for overload. Exceeding the permissible current carrying capacity may lead to connector damage.



Phoenix Contact recommends the use of pre-assembled cables.

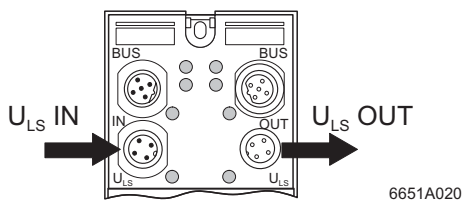

Figure 4-17 Connections for the power supply U_{LS} (FLS)

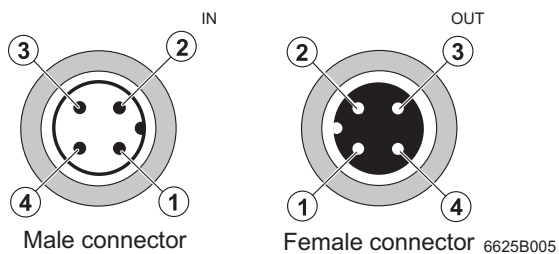

Figure 4-18 Pin assignment of the power supply U_{LS} (connections on the Fieldline Stand-Alone device)

Table 4-1 Pin assignment of the power supply U_{LS} (FLS)

Pin	IN	OUT	Wire Color
1	$U_L +24\text{ V}$	$U_L +24\text{ V}$	Brown
2	$U_S\text{ GND}$	$U_S\text{ GND}$	White
3	$U_L\text{ GND}$	$U_L\text{ GND}$	Blue
4	$U_S +24\text{ V}$	$U_S +24\text{ V}$	Black



NOTE:

The power supplies U_L and U_S should only be supplied with SELV (Safety Extra-Low Voltage).

Mounting Fieldline Devices and Connecting Cables

Power supply U_{LS} for Fieldline Modular M12 Devices

Connect the power supplies for the communications power and the sensors U_{LS} to female connector U_{LS} IN. To supply other devices, connect the cable for the outgoing supply voltage to female connector U_{LS} OUT.



NOTE:

The current carrying capacity of the M12 connectors is 4 A per contact. Ensure that this value is not exceeded. Please note that the connection for the outgoing supply voltage is not monitored for overload. Exceeding the permissible current carrying capacity may lead to connector damage.



Phoenix Contact recommends the use of pre-assembled cables.

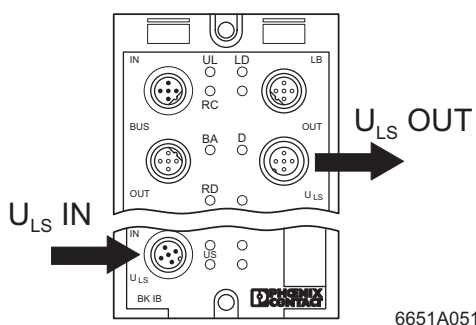

6651A051

Figure 4-19 Connections for the power supply U_{LS} of the bus couplers (FLM)



NOTE:

Voltages U_L and U_S at female connector U_{LS} OUT can each only carry a maximum current of 2 A.

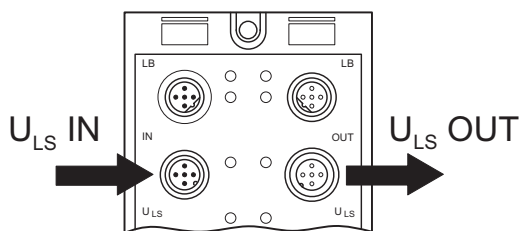

6651A052

Figure 4-20 Connections for the power supply U_{LS} on the digital and analog M12 input and output devices (FLM)



NOTE:

Voltages U_L and U_S at female connector U_{LS} OUT can each only carry a maximum current of 4 A.

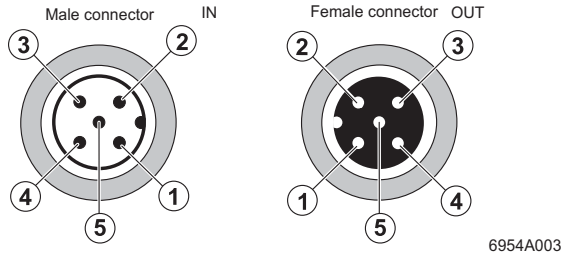

Figure 4-21 Pin assignment of the power supply U_{LS} (connections on the Fieldline Modular M12 device)

Table 4-2 Pin assignment of the power supply U_{LS} for Fieldline Modular M12 devices (FLM)

Pin	IN	OUT	Wire Color
1	$U_L +24\text{ V}$	$U_L +24\text{ V}$	Brown
2	$U_S\text{ GND}$	$U_S\text{ GND}$	White
3	$U_L\text{ GND}$	$U_L\text{ GND}$	Blue
4	$U_S +24\text{ V}$	$U_S +24\text{ V}$	Black
5	500 kbaud / 2 Mbaud	500 kbaud / 2 Mbaud	Green/yellow or gray



The transmission speed is switched to 2 Mbaud by jumpering +24 V (U_L , pin 1) to pin 5 on the bus coupler. For safety reasons, the pins should be jumpered on the last device of the local bus station.
For Ethernet and PROFINET IO, please refer to the relevant data sheet.

Mounting Fieldline Devices and Connecting Cables

Power supply U_{LS} for Fieldline Modular M8 devices



NOTE:

The current carrying capacity of the M8 connectors is 3 A per contact. Ensure that this value is not exceeded. Please note that the connection for the outgoing supply voltage is not monitored for overload. Exceeding the permissible current carrying capacity may lead to connector damage.



Phoenix Contact recommends the use of pre-assembled cables.

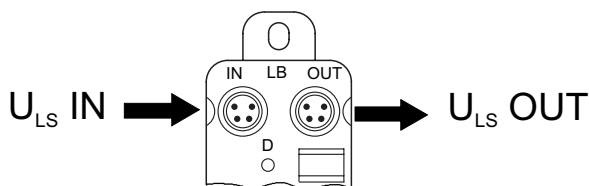

6651B073

Figure 4-22 Connections for the power supply on the digital FLM M8 input and output devices



With FLM M8 DI devices, voltage U_{LS} supplies the sensors and logic.
With FLM M8 DIO devices, voltage U_{LS} supplies the logic and voltage U_A the sensors and actuators.

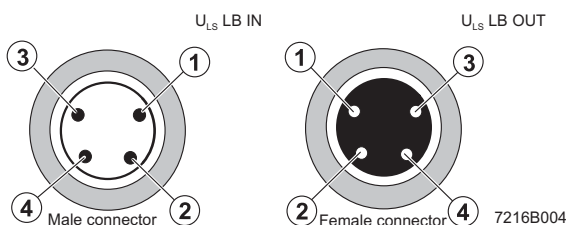

Figure 4-23 Pin assignment of the power supply U_{LS} and the local bus (FLM M8)

Pin assignment of the power supply U_{LS} and the local bus (FLM M8)

Pin	IN	OUT	Wire Color
1	$U_{LS} +24\text{ V}$	$U_{LS} +24\text{ V}$	Red
2	DI	DO	Yellow
3	$U_{LS}\text{ GND}$	$U_{LS}\text{ GND}$	Blue
4	$\overline{\text{DI}}$	$\overline{\text{DO}}$	Green



NOTE:

Voltage U_{LS} at female connector OUT can only carry a maximum current of 3 A. The thread is used for shielding.

4.7.2 Power Supply U_A

Power supply U_A for FLS and FLM M12 devices

The power supply U_A is required to supply the actuators. It is only connected to devices with outputs.



NOTE:

The connections for U_A have different functions for output devices (DO devices) and I/O devices (DIO devices). Figure 4-24 provides examples for the different device types.

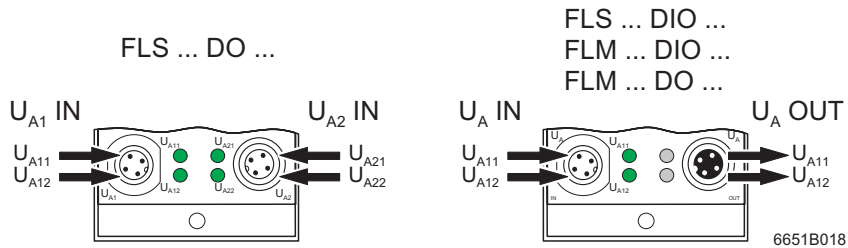

Figure 4-24 U_A connections for DO and DIO devices (FLS and FLM M12)

The different functions of the connections - supply for DO devices and supply and forwarding for DIO devices - are due to the different number of outputs and their nominal current. Two voltages are connected to each connection for supplying U_A , e.g., the voltages U_{A11} and U_{A12} at U_{A1} . Each of these supply voltages supplies a group of outputs. The advantage of this structure is that the outputs can be switched off in groups.

For information about which outputs are supplied from which voltage, see the examples in Section "Power Supply for Sensors and Actuators in Individual Fieldline Stand-Alone Devices" on page 4-25 and Section "Power Supply for Sensors and Actuators in Individual Fieldline Modular M12 Devices" on page 4-27.



NOTE:

Connect each of the supply voltages completely (to +24 V and GND). Do not connect several supply voltages via one GND, as this would exceed the current carrying capacity of the contacts.

When determining the load for a supply voltage, take into account the number of outputs, the nominal current, and the simultaneity.

Power supply U_A for M8 devices

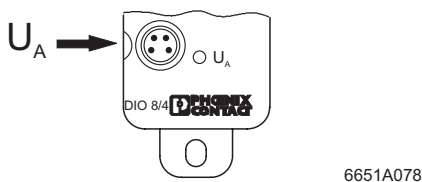

Figure 4-25 U_A connection for Fieldline Modular DIO/DO M8 devices

With Fieldline Modular M8 devices, voltage U_A is led twice through the supply line. This allows for a total current carrying capacity of 6 A.

For information about which outputs are supplied from which voltage, see the examples in Section "Power Supply for Sensors and Actuators in Individual Fieldline Modular M8 Devices" on page 4-30.

Pin assignment of the power supply U_A for Fieldline Stand-Alone devices

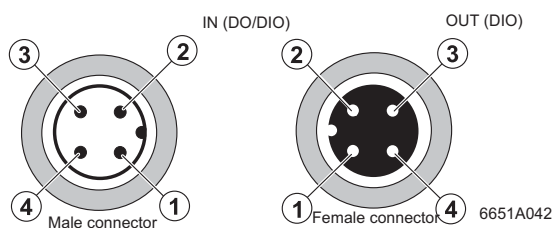

Figure 4-26 Pin assignment of the power supply U_A of the outputs (connections on the Fieldline Stand-Alone device)

Table 4-3 Pin assignment of the power supply U_A (FLS)

Pin	IN (DIO/DO)	OUT (DIO)	IN (DO-2A)	Wire Color
1	$U_{A11} +24\text{ V}$	$U_{A11} +24\text{ V}$	$U_{A21} +24\text{ V}$	Brown
2	$U_{A12}\text{ GND}$	$U_{A12}\text{ GND}$	$U_{A22}\text{ GND}$	White
3	$U_{A11}\text{ GND}$	$U_{A11}\text{ GND}$	$U_{A21}\text{ GND}$	Blue
4	$U_{A12} +24\text{ V}$	$U_{A12} +24\text{ V}$	$U_{A22} +24\text{ V}$	Black



NOTE:

The power supply U_A should only be supplied with SELV (Safety Extra-Low Voltage).

Pin assignment of the power supply U_A for Fieldline Modular M12 devices

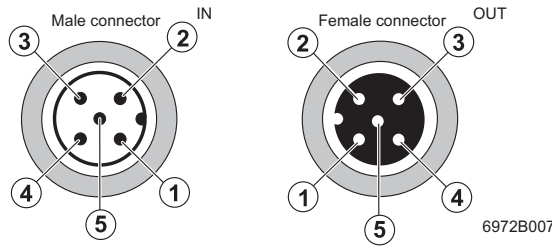

Figure 4-27 Pin assignment of the power supply U_A of the outputs (connections on the Fieldline Modular device)

Table 4-4 Pin assignment of the power supply U_A of the outputs (connections on the Fieldline Modular M12 device)

Pin	IN	OUT	Wire Color
1	$U_{A11} +24\text{ V}$	$U_{A11} +24\text{ V}$	Brown
2	$U_{A12}\text{ GND}$	$U_{A12}\text{ GND}$	White
3	$U_{A11}\text{ GND}$	$U_{A11}\text{ GND}$	Blue
4	$U_{A12} +24\text{ V}$	$U_{A12} +24\text{ V}$	Black
5	Not used	Not used	Green/yellow or gray



NOTE:

The power supply U_A should only be supplied with SELV (Safety Extra-Low Voltage).

Pin assignment of the power supply U_A for Fieldline Modular M8 devices

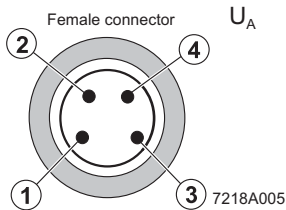

Figure 4-28 Pin assignment of the power supply U_A of the outputs (connections on the Fieldline Modular M8 device)

Table 4-5 Pin assignment of the power supply U_A of the outputs (connections on the Fieldline Modular M8 device)

Pin	Assignment	Wire Color
1	24 V U_A	Brown
2	GND U_A	White
3	GND U_A	Blue
4	24 V U_A	Black



NOTE:

The power supply U_A should only be supplied with SELV (Safety Extra-Low Voltage). With the FLM DIO 8/4 M8, U_A is also used to supply the sensors.

4.7.3 Power Supply for Sensors and Actuators in Individual Fieldline Stand-Alone Devices



The following figures provide **examples** of which inputs and outputs are supplied by which supply voltage.

For the actual assignment of your device, please refer to the device-specific data sheet.

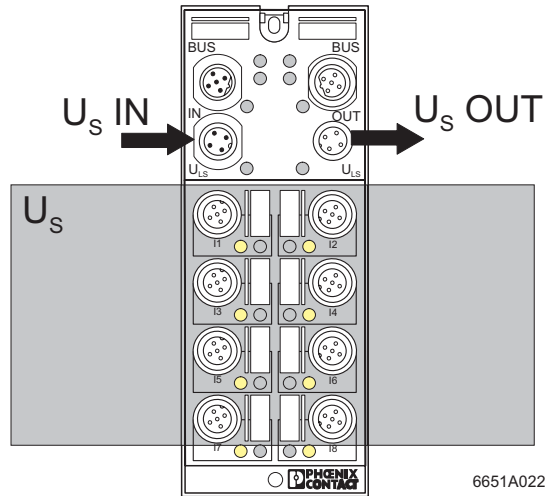

Figure 4-29 Input supply
(digital input device, e.g., FLS IB M12 DI 8 M12)

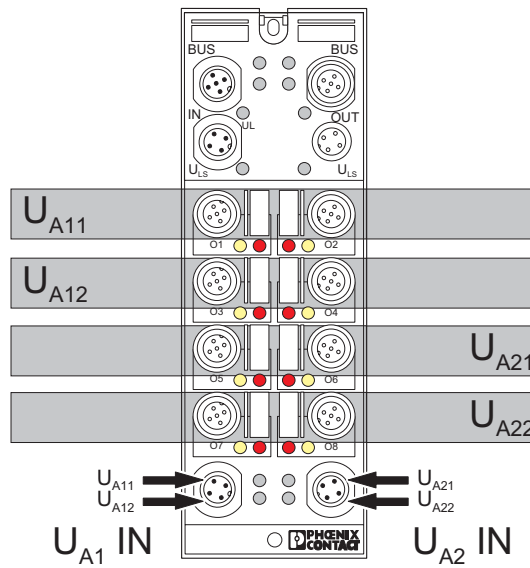

Figure 4-30 Output supply
(digital output device, e.g., FLS IB M12 DO 8 M12-2A)

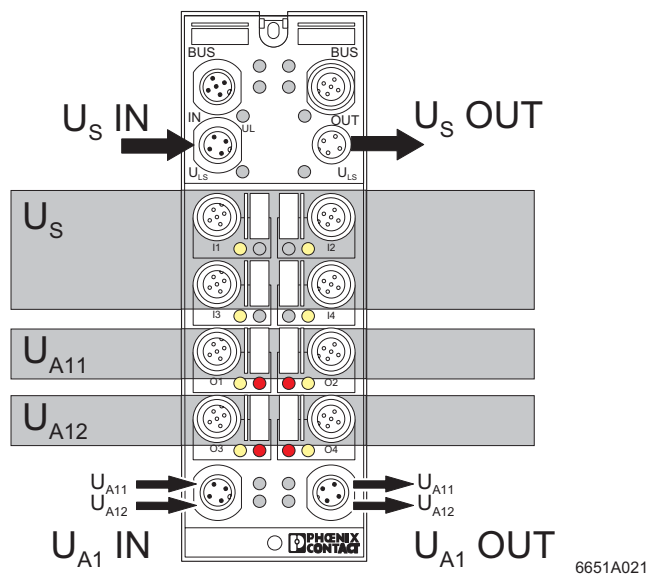
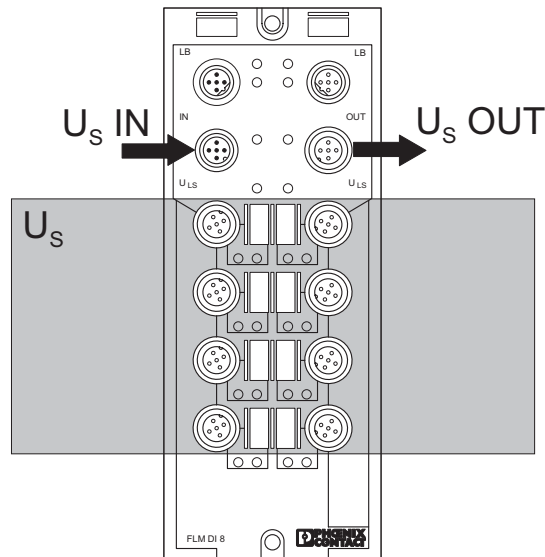

Figure 4-31 Input and output supply (digital I/O device, e.g., FLS IB M12 DIO 4/4 M12-2A)

4.7.4 Power Supply for Sensors and Actuators in Individual Fieldline Modular M12 Devices



The following figures provide **examples** of which inputs and outputs are supplied by which supply voltage.
 For the actual assignment of your device, please refer to the device-specific data sheet.



6651A055

Figure 4-32 Input supply
 (digital input device, e.g., FLM DI 8 M12)

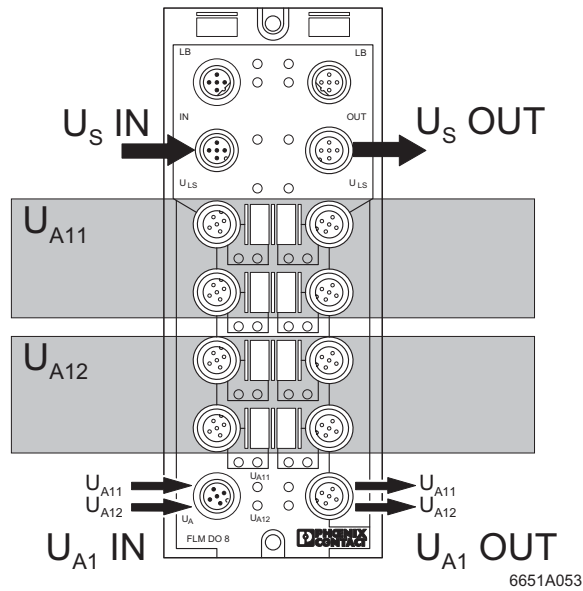

Figure 4-33 Output supply
(digital output device, e.g., FLM DO 8 M12)

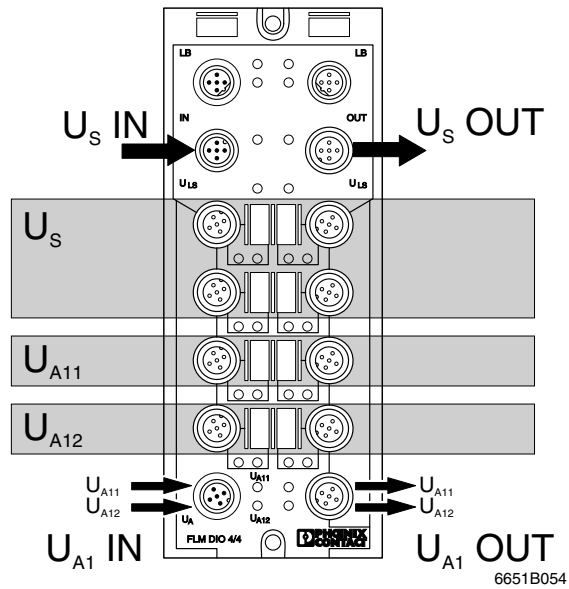

Figure 4-34 Input and output supply
(digital I/O device, e.g., FLM DIO 4/4 M12-2A)

Mounting Fieldline Devices and Connecting Cables

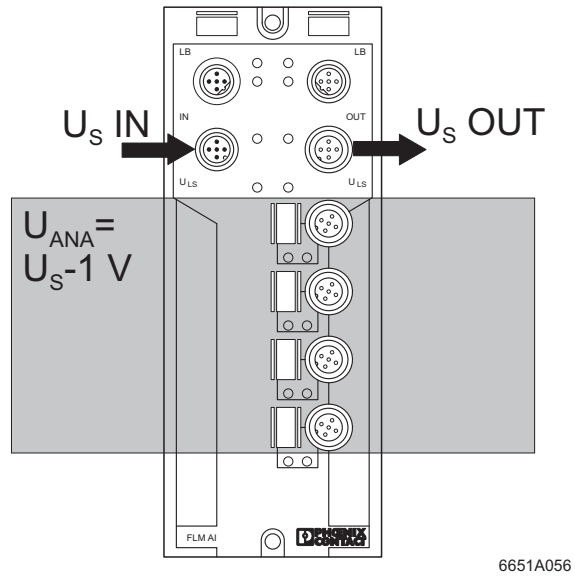

Figure 4-35 Input and output supply (analog device, e.g., FLM AI 4 SF M12)

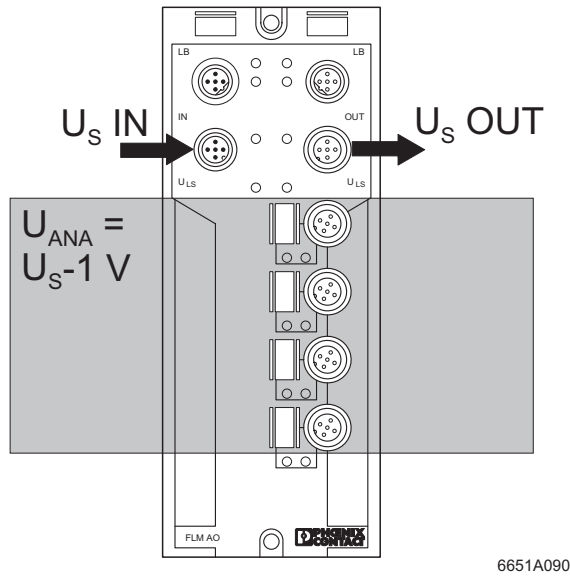

Figure 4-36 Output supply (analog device, e.g., FLM AO 4 SF M12)

4.7.5 Power Supply for Sensors and Actuators in Individual Fieldline Modular M8 Devices



The following figures provide **examples** of which inputs and outputs are supplied by which supply voltage.
 For the actual assignment of your device, please refer to the device-specific data sheet.

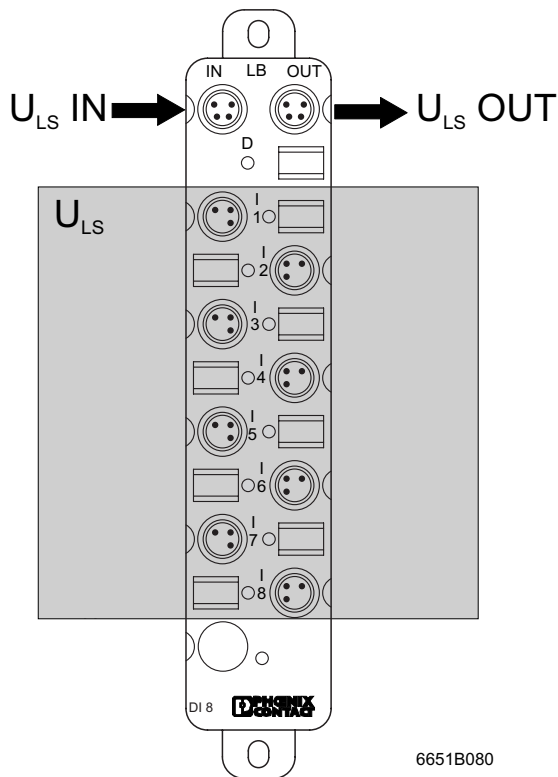
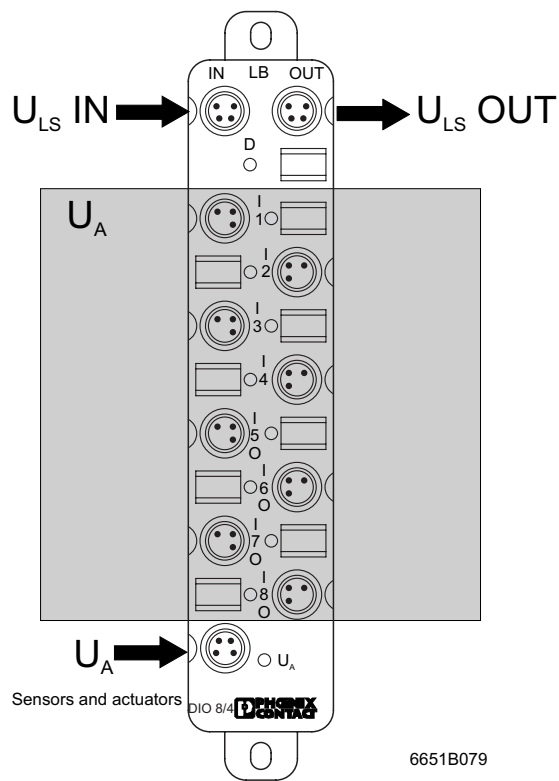

Figure 4-37 Input supply (digital input device, e.g., FLM DI 8 M8)

Mounting Fieldline Devices and Connecting Cables



6651B079

Figure 4-38 Input and output supply
(digital I/O device, e.g., FLM DIO 8/4 M8)



Output devices and combined input and output devices only use the communications power from the M8 system cable.

4.7.6 Voltage Supply Examples

FLS

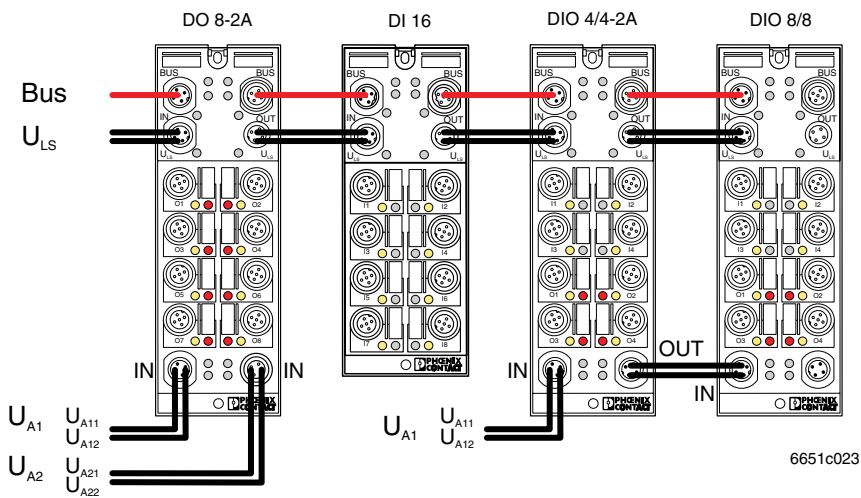

Figure 4-39 Example for the supply and forwarding of supply voltages (FLS)

FLM M12

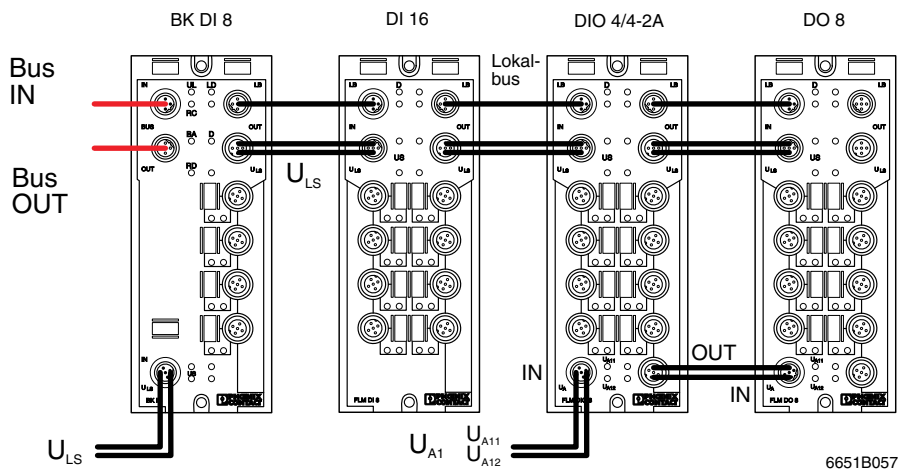

Figure 4-40 Example for the supply and forwarding of supply voltages (FLM M12)



NOTE:

The current carrying capacity of the M12 connectors is 4 A per contact. Ensure that this value is not exceeded. Please note that the connection for the outgoing supply voltage is not monitored for overload. Exceeding the permissible current carrying capacity may lead to connector damage.

Mounting Fieldline Devices and Connecting Cables

FLM M8

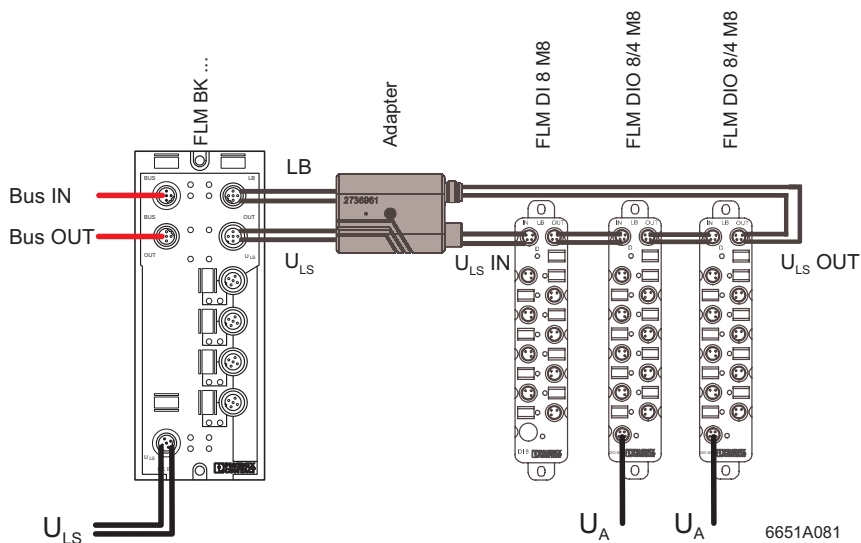

Figure 4-41 Example for the supply and forwarding of supply voltages (FLM M8)



NOTE:

The current carrying capacity of the M8 connectors is 3 A per contact. Ensure that this value is not exceeded. Please note that the connection for the outgoing supply voltage is not monitored for overload. Exceeding the permissible current carrying capacity may lead to connector damage.



If U_{LS} is directly supplied to the adapter from the bus coupler, the maximum current load is 2 A. If power is supplied again at an M12 bus device before the adapter, the maximum current load for the M8 bus devices on the local bus is 3 A.

If U_A is supplied in 4-pos. method at an M8 bus device, the maximum current load is 2 x 3 A.

**Example for Optional Supply Via a Y Cable With Reduced Current
(for Fieldline Stand-Alone Devices Only)**

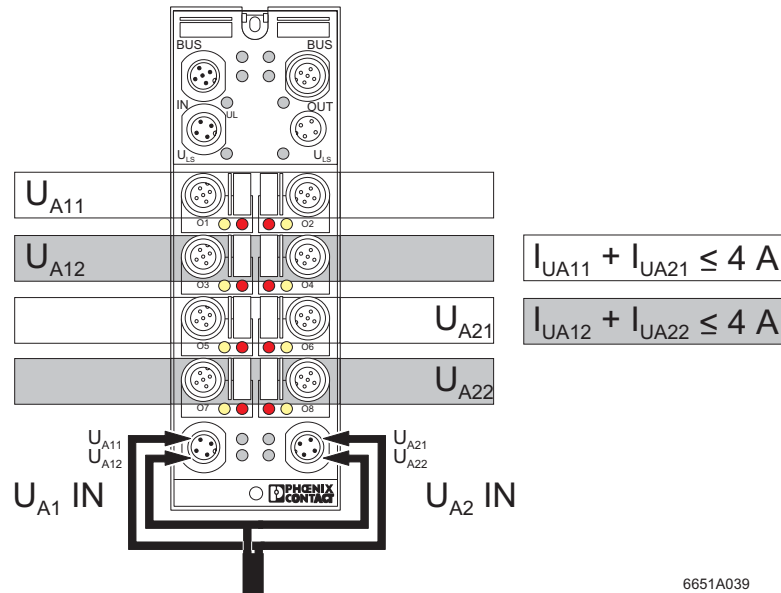

Figure 4-42 Supply via a Y cable (FLS)

If you are working with reduced current, you can use a Y cable to supply the supply voltages U_A . In this case, the following conditions must be met for the currents:



NOTE:

The total current at U_{A11} and U_{A21} must not exceed 4 A.
The total current at U_{A12} and U_{A22} must not exceed 4 A.

Mounting Fieldline Devices and Connecting Cables

Example of Switching Off Specific Outputs on a Fieldline Stand-Alone M12 Device

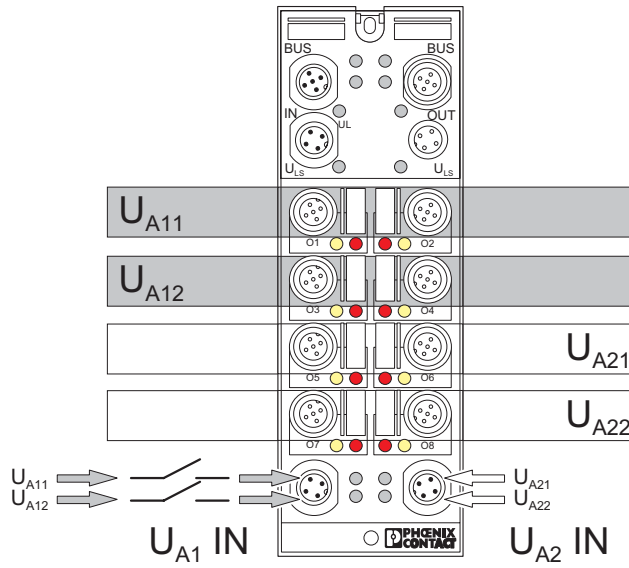

6651A040

Figure 4-43 Switching off specific outputs (FLS)

If you switch off the voltage U_{A11}/U_{A12} , outputs O1 to O4 are switched off. Outputs O5 to O8 can still be operated independently.

4.7.7 Calculation Examples for Sensor and Actuator Currents

Calculation example for an FLM bus coupler

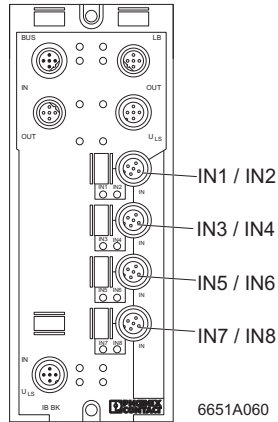

Figure 4-44 FLM BK IB M12 DI 8 M12

Sensor type:	Current consumption:
2 x reflex optical data link with 2 output signals	30 mA each
2 x inductive sensors	15 mA each

Calculation example for a bus coupler

IN1, IN2	Reflex optical data link	30 mA
IN3, IN4	Reflex optical data link	+ 30 mA
IN5	Inductive sensor	+ 15 mA
IN7	Inductive sensor	+ 15 mA

Sensor supply = **90 mA**

Current consumption of inputs (5 mA for each input used) + **30 mA**

I_{US} total = **120 mA**

With this configuration, the FLM BK loads U_S with approximately 120 mA. U_L is loaded with approximately 70 mA (see data sheet).



NOTE:

Voltages U_L and U_S each have a maximum load of 2 A at the bus coupler.

Mounting Fieldline Devices and Connecting Cables

Calculation example for an FLM DI 8 M12 device

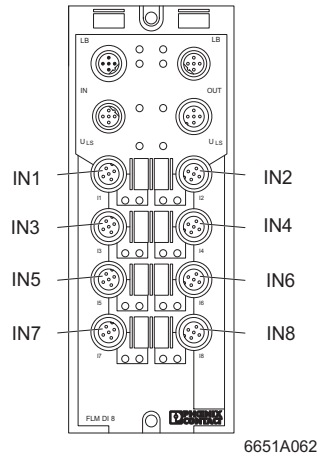

Figure 4-45 FLM DI 8 M12

Sensor type:

1 x reflex optical data link with 2 output signals

2 x inductive sensors

3 x proximity switches

Current consumption:

30 mA

15 mA each

10 mA each

Calculation example for an FLM DI 8 M12 device

IN1, IN2	Reflex optical data link	30 mA
IN3	Inductive sensor	+ 15 mA
IN4	Inductive sensor	+ 15 mA
IN5	Proximity switch	+ 10 mA
IN6	Proximity switch	+ 10 mA
IN7	Proximity switch	+ 10 mA

Sensor supply = 90 mA

**Current consumption of inputs
(5 mA for each input used) + 35 mA**

I_{US} total = 125 mA

With this configuration, the FLM DI 8 M12 device loads U_S with approximately 125 mA. U_L is loaded with approximately 40 mA (see data sheet).

FLS FLM SYS INST UM E

Calculation example for an
FLS DIO 4/4 device

Figure 4-46 FLS M12 DIO 4/4 M12-2A

Sensor type:

1 x reflex optical data link with 2 output signals
2 x proximity switches

Current consumption:

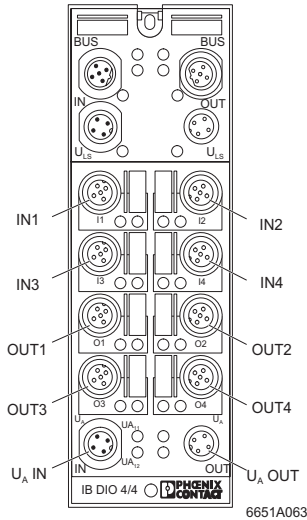
30 mA
15 mA each

Actuator type:

2 x solenoid valves (hydraulic)
2 x solenoid valves (pneumatic)

1.3 A each
67 mA each

Calculation example for an FLS DIO 4/4 device

IN1, IN2	Reflex optical data link	30 mA
IN3	Proximity switch	+ 15 mA
IN4	Proximity switch	+ 15 mA

Sensor supply = **60 mA**

Current consumption of inputs (5 mA for each input used) + **20 mA**

I_{US} total = **80 mA**

Current consumption of actuators U_{A11}

OUT1	Solenoid valve (hydraulic)	+ 1.3 A
OUT2	Solenoid valve (pneumatic)	+ 67 mA

I_{UA11} total = **1.367 A**

Current consumption of actuators U_{A12}

OUT3	Solenoid valve (hydraulic)	1.3 A
OUT4	Solenoid valve (pneumatic)	+ 67 mA

I_{UA12} total = **1.367 A**

With this configuration, the FLS DIO 4/4 device loads U_S with approximately 80 mA. U_L is loaded with approximately 40 mA (see data sheet). U_{A11} is loaded with approximately 1.367 A. U_{A12} is loaded with approximately 1.367 A.

Calculation example for an FLM DO 8 M12 device

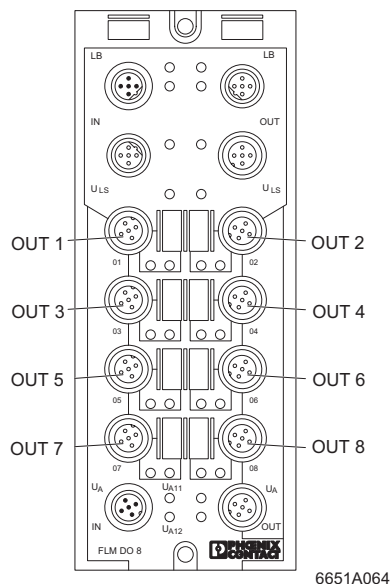

Figure 4-47 FLM DO 8 M12

Actuator type:

4 x solenoid valves (pneumatic)

Current consumption:

67 mA

Calculation example for an FLM DO 8 M12 device

Current consumption of actuators U_{A11}

OUT1	Solenoid valve (pneumatic)	67 mA
OUT2	Solenoid valve (pneumatic)	+ 67 mA

I_{UA11} total 134 mA

Current consumption of actuators U_{A12}

OUT5	Solenoid valve (pneumatic)	67 mA
OUT6	Solenoid valve (pneumatic)	+ 67 mA

I_{UA12} total 134 mA

With this configuration, the FLM DO 8 M12 device never loads U_S .

U_L is loaded with approximately 40 mA (see data sheet).

U_{A11} is loaded with approximately 134 mA. U_{A12} is loaded with approximately 134 mA.

Calculation example for an FLM DI 8 M8 device

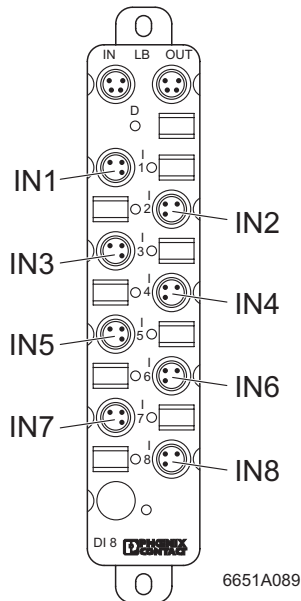

Figure 4-48 FLM DI 8 M8

Sensor type:

- 1 x reflex optical data link with 2 output signals
- 2 x inductive sensors
- 3 x proximity switches

Current consumption:

- 30 mA
- 15 mA each
- 10 mA each

Calculation example for an FLM DI 8 M8 device

IN1, IN2	Reflex optical data link	30 mA
IN3	Inductive sensor	+ 15 mA
IN4	Inductive sensor	+ 15 mA
IN5	Proximity switch	+ 10 mA
IN6	Proximity switch	+ 10 mA
IN7	Proximity switch	+ 10 mA

Sensor supply	= 90 mA
----------------------	----------------

Current consumption of inputs (5 mA for each input used)	+ 35 mA
---	----------------

I_{US} total	= 125 mA
----------------------------------	-----------------

With this configuration, the FLM DI 8 M8 device loads U_S with approximately 125 mA. U_L is loaded with approximately 40 mA (see data sheet). U_{LS} is thus loaded with approximately 165 mA.

Calculation example for an FLM DIO 8/4 M8 device

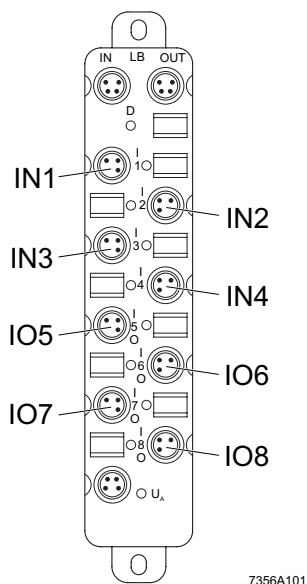

Figure 4-49 FLM DIO 8/4 M8

Sensor type:

1 x reflex optical data link with 2 output signals

2 x proximity switches

Actuator type:

1 x solenoid valve (hydraulic)

1 x solenoid valve (hydraulic)

2 x solenoid valves (pneumatic)

Current consumption:

30 mA

15 mA each

0.5 A

0.3 A

67 mA

Calculation example for an FLM DIO 8/4 M8 device

IN1, IN2	Reflex optical data link	30 mA
IN3	Proximity switch	+ 15 mA
IN4	Proximity switch	+ 15 mA

Sensor supply = **60 mA**

Current consumption of inputs (5 mA for each input used) + **20 mA**

I_{US} total = **80 mA**

Current consumption of actuators U_A

OUT1	Solenoid valve (hydraulic)	+ 0.5 A
OUT2	Solenoid valve (pneumatic)	+ 67 mA
OUT3	Solenoid valve (hydraulic)	0.3 A
OUT4	Solenoid valve (pneumatic)	+ 67 mA

I_{UA} total = **0.934 A**

With this configuration, the FLM DIO 8/4 M8 device loads U_S with approximately 80 mA. U_L is loaded with approximately 55 mA (see data sheet). Due to the outputs U_A is loaded with approximately 0.934 A. The total load U_a and U_S is 1.114 A.

Calculation example for an FLM DO4 M8-2A device

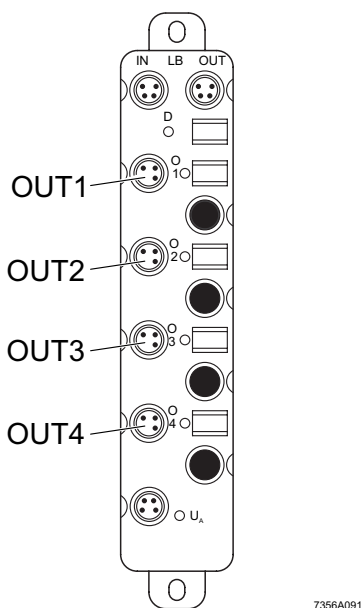

Figure 4-50 FLM DO 4 M8-2A

Calculation example for an FLM DO 4 M8-2A device

Current consumption of actuators I_{UA}

OUT1	Solenoid valve (hydraulic)	0.8 A
OUT2	Solenoid valve (pneumatic)	+ 67 mA
OUT3	Solenoid valve (hydraulic)	0.8 A
OUT4	Solenoid valve (pneumatic)	+ 67 mA
I_{UA} total		1.734 A

With this configuration, the FLM DO 4 M8-2A device loads U_L with approximately 55 mA (see data sheet). Due to the outputs U_A is loaded with approximately 1.734 A.

Mounting Fieldline Devices and Connecting Cables

Calculation example for an FLM M12 station

The following example combines the individual devices from the previous examples to form a station.

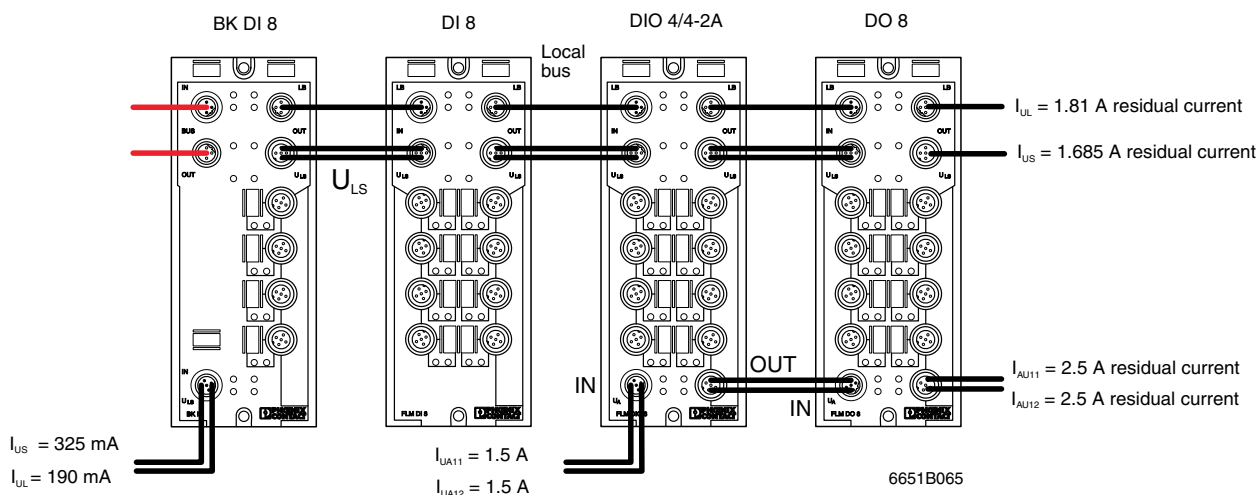

Figure 4-51 FLM M12 station

	Bus Coupler	DI 8 Device	DIO 4/4 Device	DO 8 Device	Station	Maximum Current
I_{UL}	+ 70 mA	+ 40 mA	+ 40 mA	+ 40 mA	= 190 mA	2 A
I_{US}	+ 120 mA	+ 125 mA	+ 80 mA	-	= 325 mA	2 A
I_{UA11}	-	-	1.367 A	+ 134 mA	= 1.5 A	4 A
I_{UA12}	-	-	1.367 A	+ 134 mA	= 1.5 A	4 A



NOTE:
 Voltages U_{A11} and U_{A12} should be loaded equally.

FLS FLM SYS INST UM E

Calculation example for an FLM M12/M8 station

The following example combines the individual devices from the previous examples to form a station.

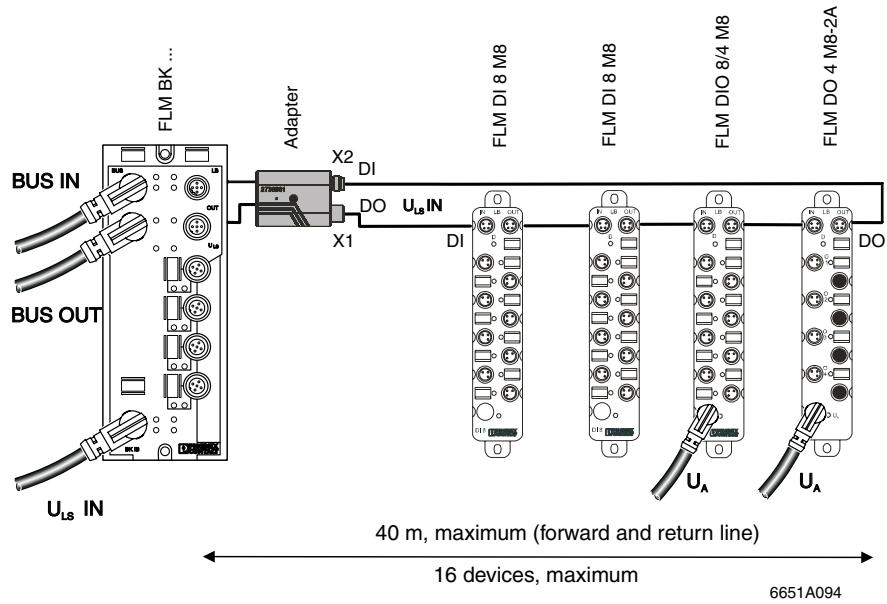

Figure 4-52 FLM M12/M8 station

	Bus Coupler	DI 8 Device	DI 8 Device	DIO 8/4 Device	DO 4 Device	Station	Maximum Current
I_{UL}	+ 70 mA	+ 40 mA	+ 40 mA	+ 55 mA	+ 55 mA	= 260 mA	2 A
I_{US}	+ 120 mA	+ 125 mA	+ 125 mA	+ 80 mA	-	= 450 mA	2 A
I_{UA}	-	-	-	1.114 A	1.734 A	= 2.848 A	2 x 3 A



NOTE:

Voltages U_{A11} and U_{A12} should be loaded equally.

Mounting Fieldline Devices and Connecting Cables

Calculation example for an FLM M8 station connected to Inline

The following example combines the individual devices from the previous examples to form a station.

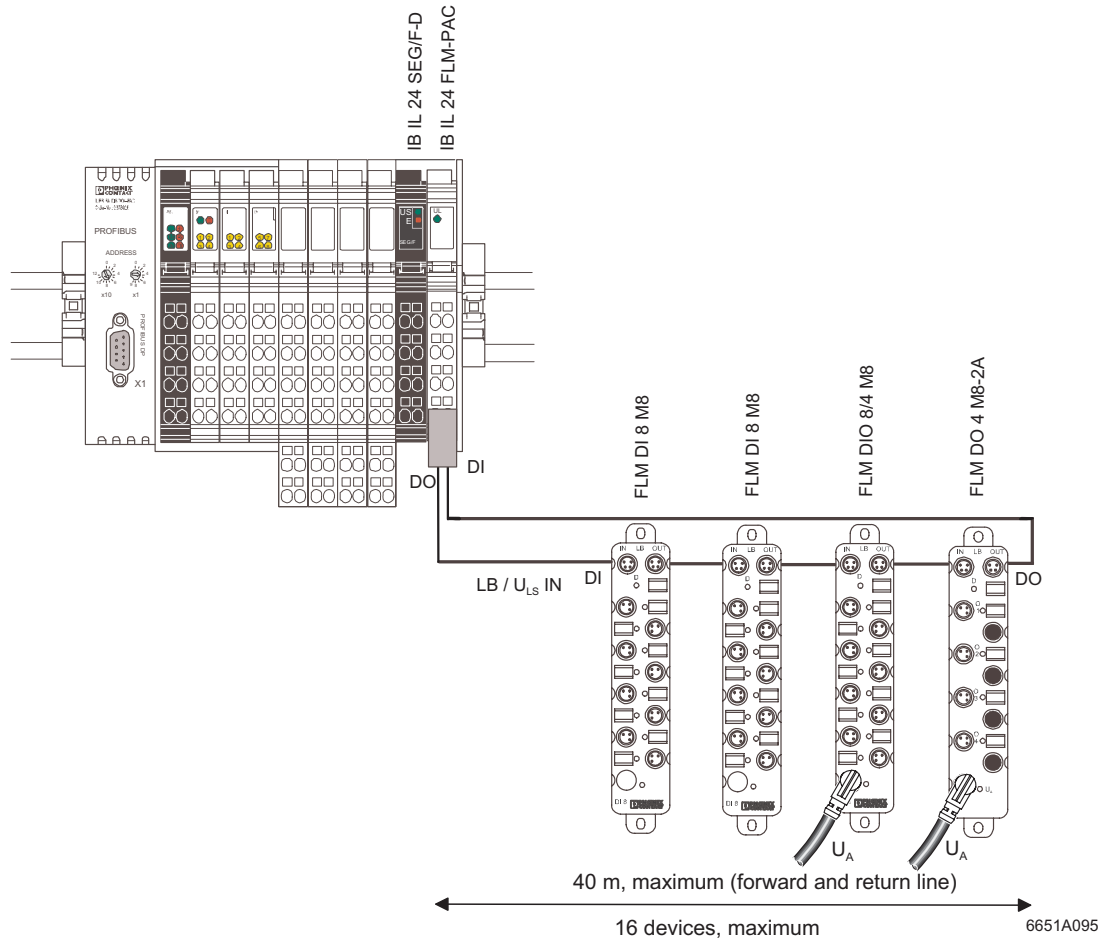

Figure 4-53 InLine/M8 station

	DI 8 Device	DI 8 Device	DIO 8/4 Device	DO 4 Device	Station	Maximum Current
I_{UL}	+ 40 mA	+ 40 mA	+ 55 mA	+ 55 mA	= 190 mA	3 A
I_{US}	+ 125 mA	+ 125 mA	+ 80 mA	-	= 330 mA	3 A
I_{UA}	-	-	1.114 A	1.734 A	= 2.848 A	2 x 3 A

4.7.8 Supply Line and Current Supply (M12)

For M12 connectors in Fieldline devices, a **maximum of 4 A per contact** is permitted.

To ensure this condition is met, the following factors should be considered:

1. Current consumption of the Fieldline devices (see data sheets)
2. Current consumption of the connected sensors
3. Current consumption of the connected actuators
4. Length of the cables and losses on these cables



It is particularly important to observe these factors when forwarding the supply voltage.

Examples

Detail A in Figure 4-54: On an FLS IB DIO 4/4 M12-2A Fieldline device, if both outputs of a group are loaded with 2 A simultaneously, the supply voltage for these outputs cannot be forwarded.

Detail B in Figure 4-54: On the same Fieldline device, if both outputs of a group are loaded with 0.5 A simultaneously, the supply voltage for these outputs can be forwarded. Forwarding would also be permitted, for example, if the outputs were each loaded with 2 A but simultaneity was not permitted.

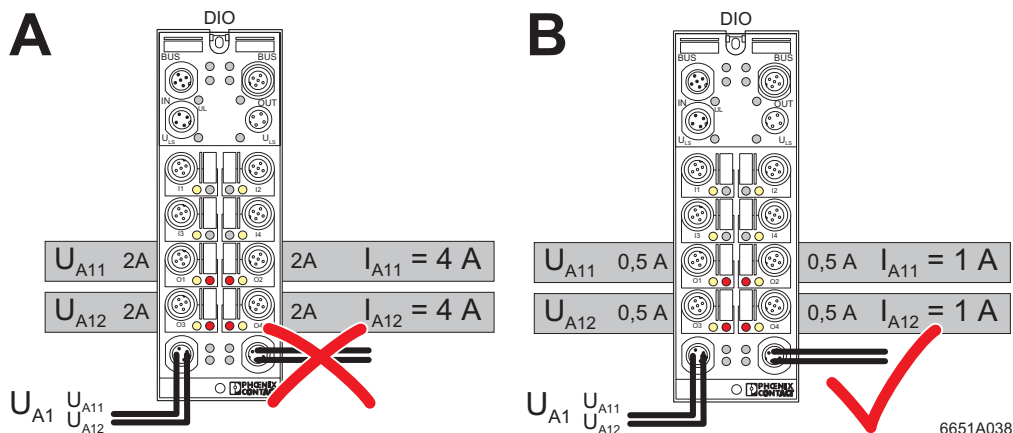

Figure 4-54 Forwarding the supply voltage

6651A038

Losses on the Cables

The voltage drop on the cables can be calculated using the formula

$$U_A = I \times R \times 2$$

Where:

U_A	Voltage drop
I	Current strength
R	Conductor resistance
2	Calculation for forward and return path

For a power supply cable 4 x 0.75 mm² cable type 186 (e.g., SAC-4P-M12MS/...-186/M12FS), the conductor resistance is 26 Ω/km.

With 4 A:

$$U_A = 4 \text{ A} \times 26 \text{ } \Omega/\text{km} \times 2 = 208 \text{ V/km} \quad \text{which corresponds to 2.08 V on 10 m}$$

With 2 A:

$$U_A = 2 \text{ A} \times 26 \text{ } \Omega/\text{km} \times 2 = 104 \text{ V/km} \quad \text{which corresponds to 1.04 V on 10 m}$$

Other cables have other specific resistance values, which can be used to calculate the voltage drop according to the above formula.

4.7.9 Supply Line and Current Supply (M8)

For M8 connectors in Fieldline devices, **a maximum of 3 A per contact** is permitted.

To ensure this condition is met, the following factors should be considered:

5. Current consumption of the Fieldline devices (see data sheets)
6. Current consumption of the connected sensors
7. Current consumption of the connected actuators
8. Length of the cables and losses on these cables

For Fieldline Modular M8 devices, it is useful to supply the ULS supply voltage on both sides. The total current for an M8 station is limited to 4 A when using an Inline segment terminal (IB IL 24 SEG/F) and the M12/8 adapter.

4.8 Connecting Sensors and Actuators

Connect the sensors and actuators using M12 or M8 connectors.



Phoenix Contact recommends the use of pre-assembled cables.



For the pin assignment of the inputs and outputs, please refer to the device-specific data sheet.



NOTE:

The maximum cable length for connecting sensors and actuators is 30 m.



SCATTERGOOD & JOHNSON LTD

ELECTRICAL ENGINEERING & FLUID CONTROL DISTRIBUTORS

Est.1899

At Scattergood & Johnson Ltd, we pride ourselves on being a technical distributor to specialist industries.

Working with a range of quality product suppliers across a number of specialist markets, we are not your average 'box shifter' - we are your technical and supply chain partner.

We fully support every product we sell - for free! Our internal team and external sales engineers can answer any product or application question, no matter the complexity.

Backing up this technical ability is a range of 50,000+ products available from stock for nationwide next day delivery (same day if required!), or you can collect what you need from any of our trade counters around the UK.

Select your specialist interest below to learn more about how we can help.

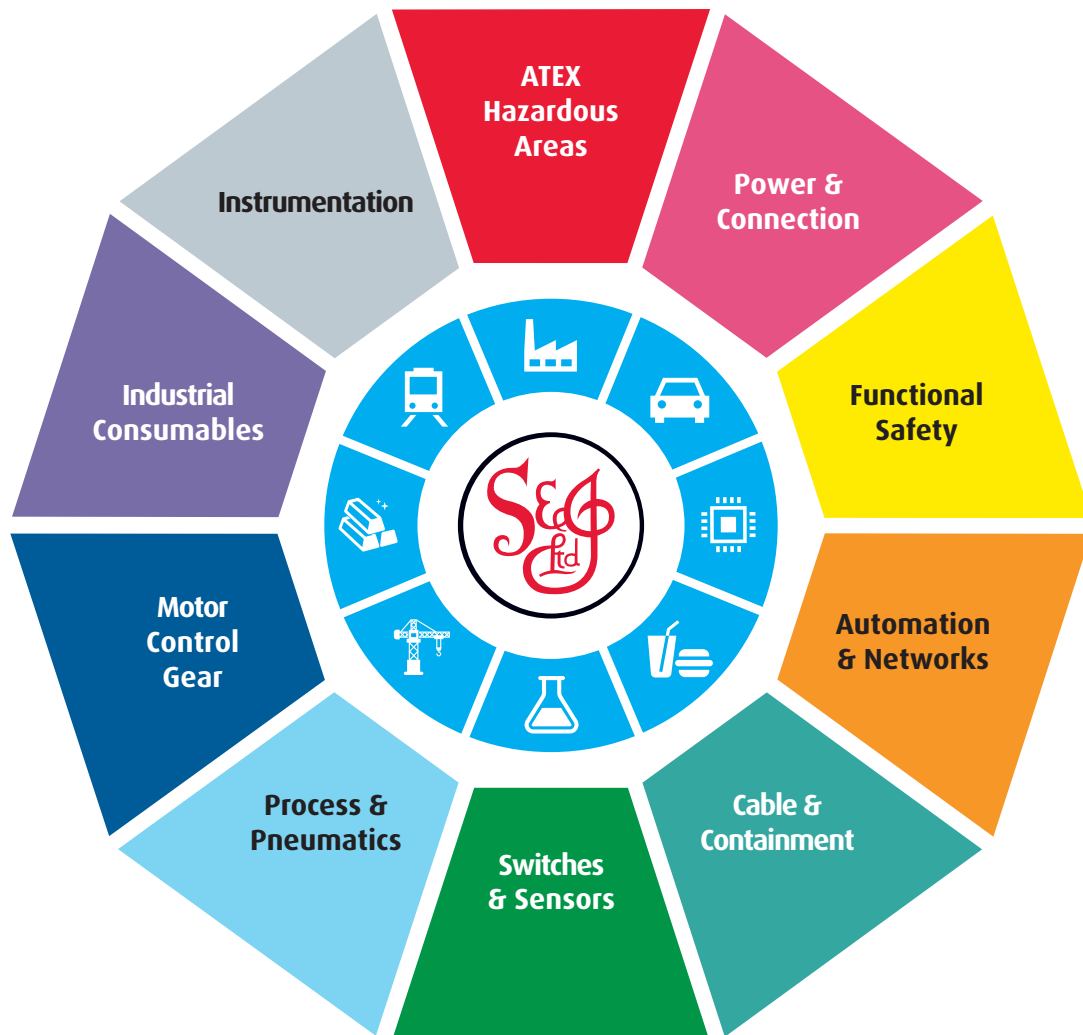

Online, In Branch and On the Road - Scattergood & Johnson Ltd, there when you need us.

www.scatts.co.uk