

# ASI MA IL UNI

## AS-Interface Gateway for Inline

Data Sheet 704100

06/2004

7041A000

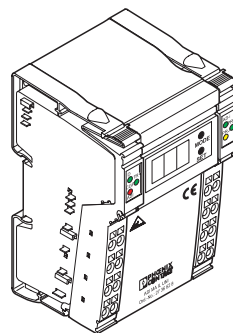

This data sheet is only valid in association with the IB IL SYS PRO UM E (Order No. 27 43 04 8) and UM EN ASI MA IL UNI (Order No. 26 99 67 1) user manuals.

## Function

The AS-Interface gateway (AS-i) is used to integrate AS-i into an Inline station.

## Features

- Diagnostic and status indicators
- Three-digit 7-segment display
- AS-i connection via Inline connector
- Local bus connection via Inline potential distributor
- Up to 62 AS-i slaves with a maximum of 248 inputs and 186 outputs
- Up to 100 m (328.08 ft.) of cable in one AS-i system

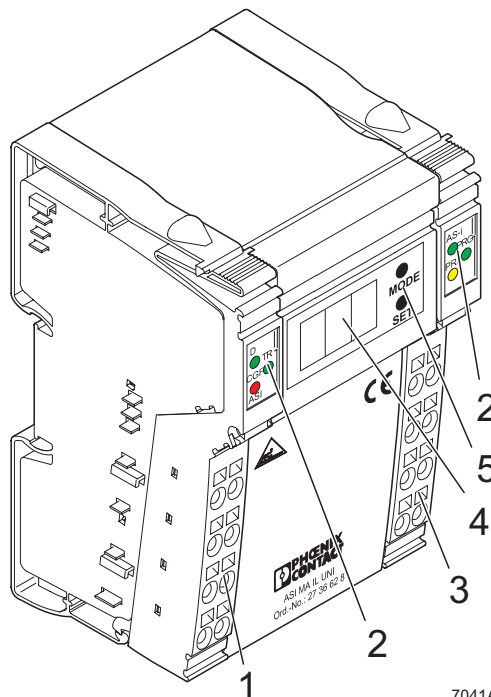

7041A001

Figure 1 ASI MA IL UNI AS-i Gateway

The AS-i gateway consists of the following components:

- 1 Configuration connector
- 2 Diagnostic and status indicators
- 3 AS-i connection
- 4 7-segment display
- 5 Configuration and diagnostic button

ASI MA IL UNI

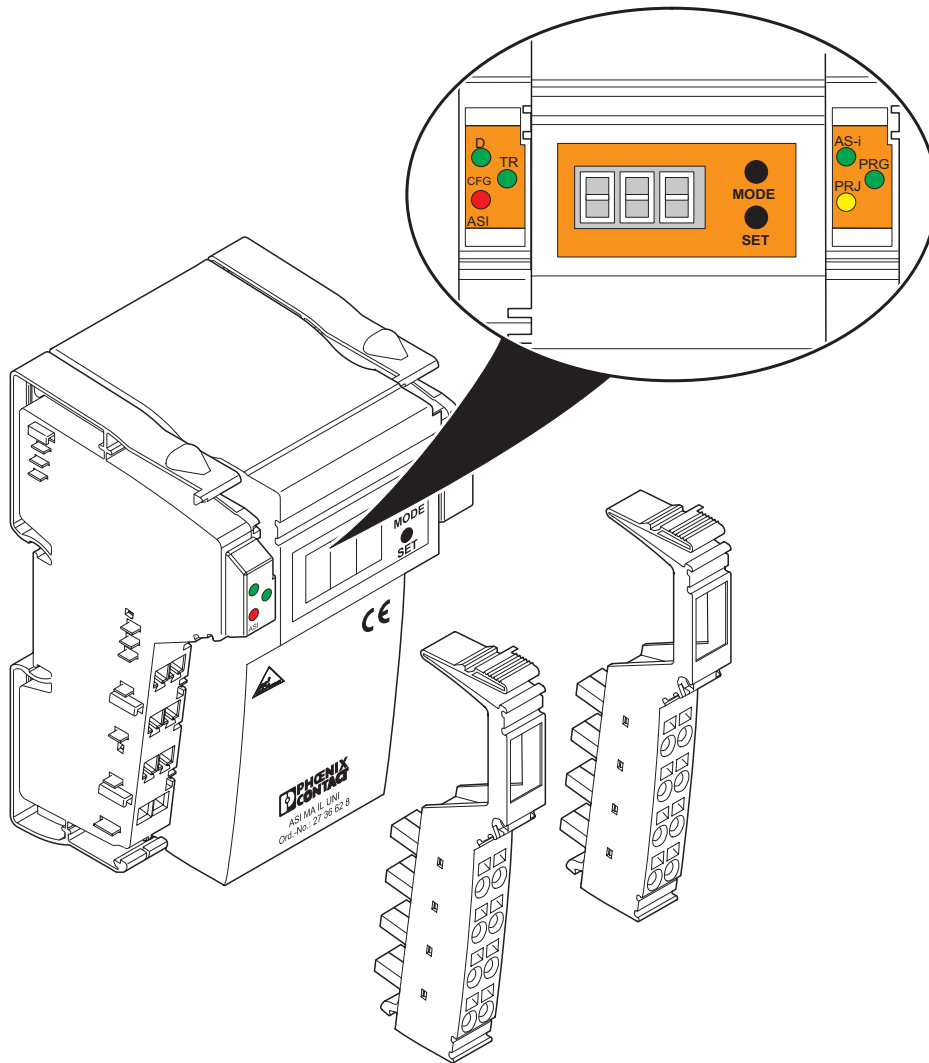

7041A003

Figure 2 ASI MA IL UNI with appropriate connectors

### Local Diagnostic and Status Indicators

Des.	Color	Meaning
<b>D</b>	Green LED	Diagnostics
	ON:	Bus active
	Flashing:	
	0.5 Hz:	Supply present, bus not active
	2 Hz:	Bus active, I/O error
	4 Hz:	Cable interrupt before the gateway
	OFF:	No communications power, bus not active
<b>TR</b>	Green LED	PCP communication
	ON:	PCP channel not active
	OFF:	PCP channel active
<b>CFG</b>	Red LED	AS-i configuration error or I/O error  The 7-segment display indicates the lowest AS-i address at which a configuration or I/O error was detected. Once the error at this AS-i address has been removed, the next AS-i address at which an error was detected is displayed if applicable.
	ON:	At least one slave address has a configuration error
	Flashing:	At least one AS-i slave has an I/O error
	OFF:	No error
<b>AS-i</b>	Green LED	AS-i operating voltage
	ON:	AS-i operating voltage is present
	OFF:	AS-i operating voltage is not present
<b>PRG</b>	Green LED	Automatic address programming
	ON:	Automatic address programming is possible  One slave is missing in the AS-i configuration, and automatic addressing is activated in the gateway (default setting). When an appropriate new slave is connected it is automatically assigned to the unused address.
	OFF:	Automatic address programming is not possible  All slaves are present in the AS-i configuration or this function is deactivated in the gateway.
<b>PRJ</b>	Yellow LED	Configuration mode
	ON:	Configuration mode is active
	OFF:	Configuration mode is not active

## ASI MA IL UNI

### Buttons

Button	Meaning
<b>MODE</b>	Activates and deactivates configuration mode Saves configuration data
<b>SET</b>	Modifies configuration data

### 7-Segment Display

The 7-segment display contains different information depending on the operating state:

- During normal operation it displays a chasing light.
- In the event of a configuration or I/O error, it displays the lowest AS-i address at which an error was detected.
- In configuration mode it indicates the slave addresses and error messages.

## An Example of INTERBUS/AS-Interface Topology

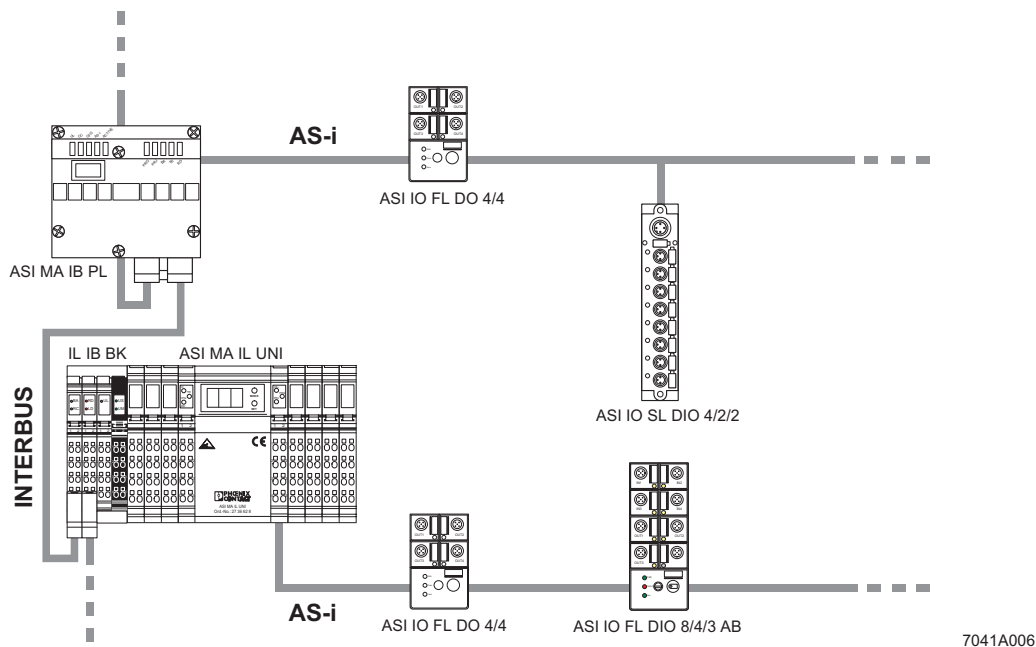
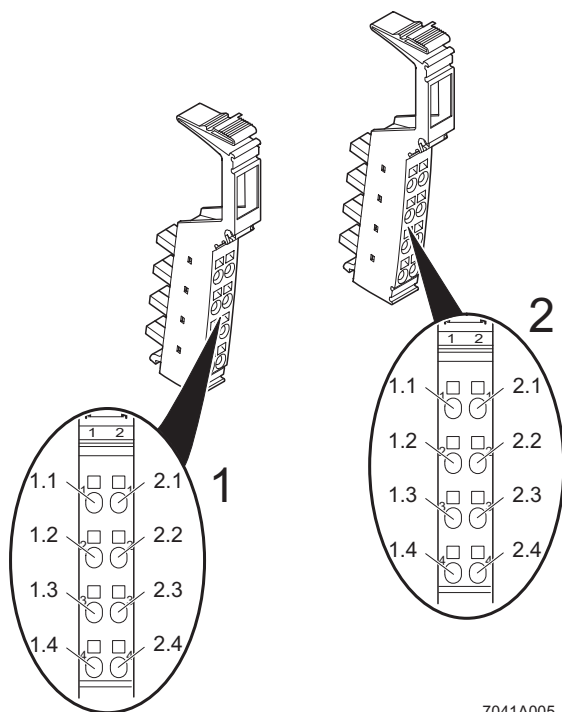

Figure 3 An example of INTERBUS/AS-Interface topology

# Terminal Point Assignment

## AS-i Connection (Connector 2)

Terminal Point	Assignment
1.1, 1.2, 1.3, 1.4	AS-i +
2.1, 2.2, 2.3, 2.4	AS-i -



7041A005

Figure 4 Terminal point assignment

## Determining the Process Data Length (Connector 1)

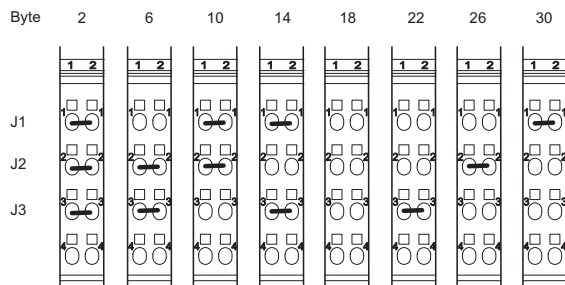

6342A002

To determine the process data length, insert jumpers in the configuration connector (connector 1) as shown in Figure 5 "Determining the process data length".

- J1 between 1.1 and 2.1
- J2 between 1.2 and 2.2
- J3 between 1.3 and 2.3

Figure 5 Determining the process data length

## Internal Circuit Diagram

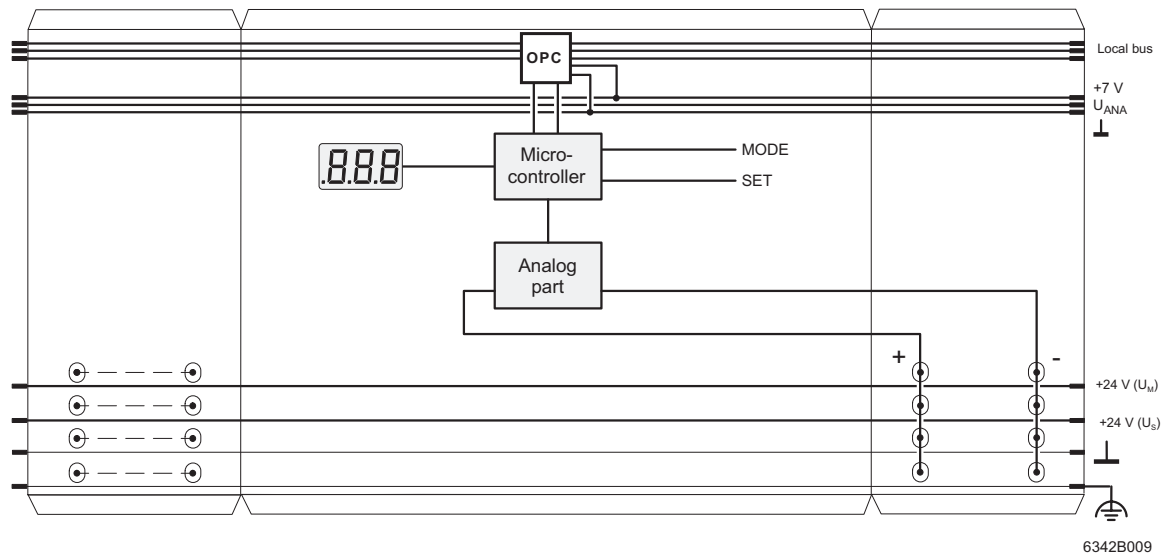

Figure 6 Internal wiring of the AS-Interface gateway

## Connection Notes



**Meet noise immunity requirements and enable insulation resistance measuring**

Observe the Inline grounding concept.

Key:



Protocol chip



Terminal point



Jumper



Other symbols used are explained in the IB IL SYS PRO UM E user manual.

## Exchanging Information via the Local Bus

### Register Structure

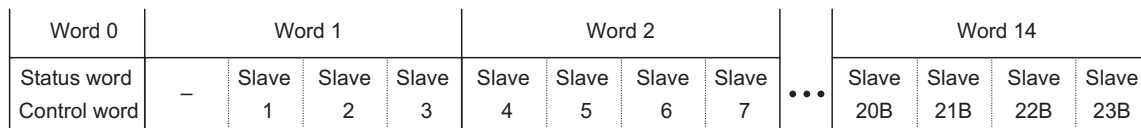

6342A008

Figure 7 Structure of the register

### Control Word

The control word is used to control the AS-i gateway. The control word is transmitted in every bus cycle.

Bus reference	Word	Control Word (Word 0)															
	Bit	15	14	13	12	11	10	9	8	7	6	5	4	3	2	1	0
(Byte.bit) view	Byte	Byte 0							Byte 1								
	Bit	7	6	5	4	3	2	1	0	7	6	5	4	3	2	1	0
Channel 1	Bit									Block module error on AS-i power failure	Block module error on AS-i configuration error	Offline phase on AS-i configuration error			Auto_prog_Dis	Offline	Data_Exchange_inactive

## ASI MA IL UNI

---

Auto_prog_Dis	Disables the option of addressing a replacement slave.
Offline	All AS-i slaves are reset. There is no communication in the AS-i network. When this bit is cleared, the AS-i network starts up again.
Data_Exchange_inactive	Data exchange in the AS-i network is interrupted, but continues immediately when this bit is cleared.
Offline phase on AS-i configuration error	If this bit is set, every configuration error triggers offline mode during normal operation in protected operating mode. If this bit is not set, the PCP object 5FDB can be used to specify separately for every slave address whether a configuration error should trigger a switch to offline mode.
Block module error on AS-i configuration error	Inhibits the module error message "AS-i configuration error".
Block module error on AS-i power failure	Inhibits the module error message "AS-i power failure".

## Status Word

The status word indicates the state of the AS-i gateway to the bus master. The status word is transmitted in every bus cycle.

Bus reference	Word	Status Word (Word 0)															
	Bit	15	14	13	12	11	10	9	8	7	6	5	4	3	2	1	0
(Byte.bit) view	Byte	Byte 0								Byte 1							
	Bit	7	6	5	4	3	2	1	0	7	6	5	4	3	2	1	0
Channel 1	Bit								Periphery_OK	Offline_Ready	APF	Normal_Mode_Active	Configuration_Mode_Active	Auto_prog_Avail	Auto_prog	LDS.0	Config_OK

Config\_OK

The desired configuration of the AS-i network is the same as the actual configuration, i.e., all parts of the AS-i network are operating and are configured correctly.

LDS.0

A slave with address 0 is connected to the AS-i network (LDS: List of **D**etected **S**laves).

Auto\_prog

Automatic slave addressing is possible.

Auto\_prog\_Avail

An error has occurred, which can be removed by automatic programming. This state occurs, e.g., if only one slave is missing. This is typical for a field repair.

## ASI MA IL UNI

Configuration_Mode_Active	The AS-i gateway is in configuration mode.
Normal_Mode_Active	The AS-i gateway is in normal operation, the AS-i cycle is running.
APF	Power failure in AS-i network (APF: <b>AS-i Power Failure</b> ). In this case, the AS-i gateway reinitializes all AS-i slaves. This is necessary because the slaves are supplied with operating voltage via the AS-i network and lose their parameter settings when the power fails.
Offline_Ready	After powerup, if the bus master has reset the AS-i gateway via the control word, and after a voltage failure in the AS-i network, the AS-i gateway takes some time to initialize and test the AS-i network. This signal is only active once this phase is complete.
Periphery_OK	None of the connected AS-i slaves are indicating an I/O error.

### Process Data Channel

In the process data channel, logical states are exchanged between the control system (PLC) and the digital sensors and actuators. In the control system, sensors and actuators are mapped in the memory as follows:

Bus reference	Word	Word 1															
	Bit	15	14	13	12	11	10	9	8	7	6	5	4	3	2	1	0
(Byte.bit) view	Byte	Byte 0								Byte 1							
	Bit	7	6	5	4	3	2	1	0	7	6	5	4	3	2	1	0
Sensors/actuators	Bit	-	-	-	-	D3	D2	D1	D0	D3	D2	D1	D0	D3	D2	D1	D0
						Slave 1/1A				Slave 2/2A				Slave 3/3A			

Bus reference	Word	Word 2															
	Bit	15	14	13	12	11	10	9	8	7	6	5	4	3	2	1	0
(Byte.bit) view	Byte	Byte 0								Byte 1							
	Bit	7	6	5	4	3	2	1	0	7	6	5	4	3	2	1	0
Sensors/actuators	Bit	D3	D2	D1	D0	D3	D2	D1	D0	D3	D2	D1	D0	D3	D2	D1	D0
		Slave 4/4A				Slave 5/5A				Slave 6/6A				Slave 7/7A			

Bus reference	Word	Word 3															
	Bit	15	14	13	12	11	10	9	8	7	6	5	4	3	2	1	0
(Byte.bit) view	Byte	Byte 0								Byte 1							
	Bit	7	6	5	4	3	2	1	0	7	6	5	4	3	2	1	0
Sensors/ actuators	Bit	D3	D2	D1	D0	D3	D2	D1	D0	D3	D2	D1	D0	D3	D2	D1	D0
		Slave 8/8A				Slave 9/9A				Slave 10/10A				Slave 11/11A			

...

Bus reference	Word	Word 8															
	Bit	15	14	13	12	11	10	9	8	7	6	5	4	3	2	1	0
(Byte.bit) view	Byte	Byte 0								Byte 1							
	Bit	7	6	5	4	3	2	1	0	7	6	5	4	3	2	1	0
Sensors/ actuators	Bit	D3	D2	D1	D0	D3	D2	D1	D0	D3	D2	D1	D0	D3	D2	D1	D0
		Slave 28/28A				Slave 29/29A				Slave 30/30A				Slave 31/31A			

Bus reference	Word	Word 9															
	Bit	15	14	13	12	11	10	9	8	7	6	5	4	3	2	1	0
(Byte.bit) view	Byte	Byte 0								Byte 1							
	Bit	7	6	5	4	3	2	1	0	7	6	5	4	3	2	1	0
Sensors/ actuators	Bit	-	-	-	-	D3	D2	D1	D0	D3	D2	D1	D0	D3	D2	D1	D0
						Slave 1B				Slave 2B				Slave 3B			

Bus reference	Word	Word 10															
	Bit	15	14	13	12	11	10	9	8	7	6	5	4	3	2	1	0
(Byte.bit) view	Byte	Byte 0								Byte 1							
	Bit	7	6	5	4	3	2	1	0	7	6	5	4	3	2	1	0
Sensors/ actuators	Bit	-	-	-	-	D3	D2	D1	D0	D3	D2	D1	D0	D3	D2	D1	D0
		Slave 4B				Slave 5B				Slave 6B				Slave 7B			

...

## ASI MA IL UNI

---

Bus reference	Word	Word 14															
	Bit	15	14	13	12	11	10	9	8	7	6	5	4	3	2	1	0
(Byte.bit) view	Byte	Byte 0								Byte 1							
	Bit	7	6	5	4	3	2	1	0	7	6	5	4	3	2	1	0
Sensors/actuators	Bit	-	-	-	-	D3	D2	D1	D0	D3	D2	D1	D0	D3	D2	D1	D0
		Slave 20B				Slave 21B				Slave 22B				Slave 23B			



As the length of the process data channel is limited, the data for slaves 24B to 31B is not displayed. This data must be accessed via the PCP channel.

- D0 Input I1 or output O1
- D1 Input I2 or output O2
- D2 Input I3 or output O3
- D3 Input I4 or output O4

With AS-i, one bit position can be used for both input and output purposes. AS-i slaves have up to four inputs and outputs, which have their own bit positions. The data of AS-i slave 0 cannot be accessed because this address is reserved for configuration mode.

### Parameter Data Channel (PCP)

Data transmission is more flexible via the parameter data channel than via the process data channel. Individual AS-i slaves can be specifically controlled or data requested.

When commands are issued, the AS-i gateway operates in pure server mode, i.e., it recognizes certain commands, which the client can send. The client is always the bus master. If several words are required per command for data transmission via the parameter data channel, these words are transmitted in successive bus cycles.

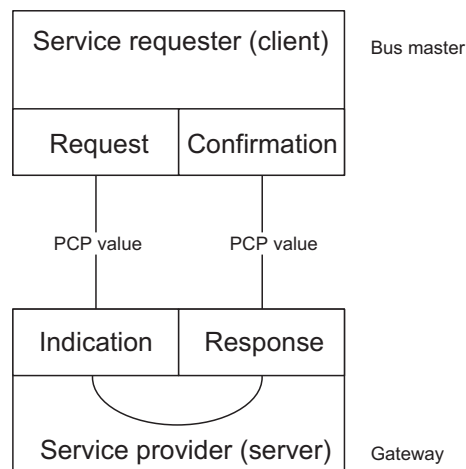

7041A010

Figure 8 Services via PCP word

ASI MA IL UNI

Technical Data

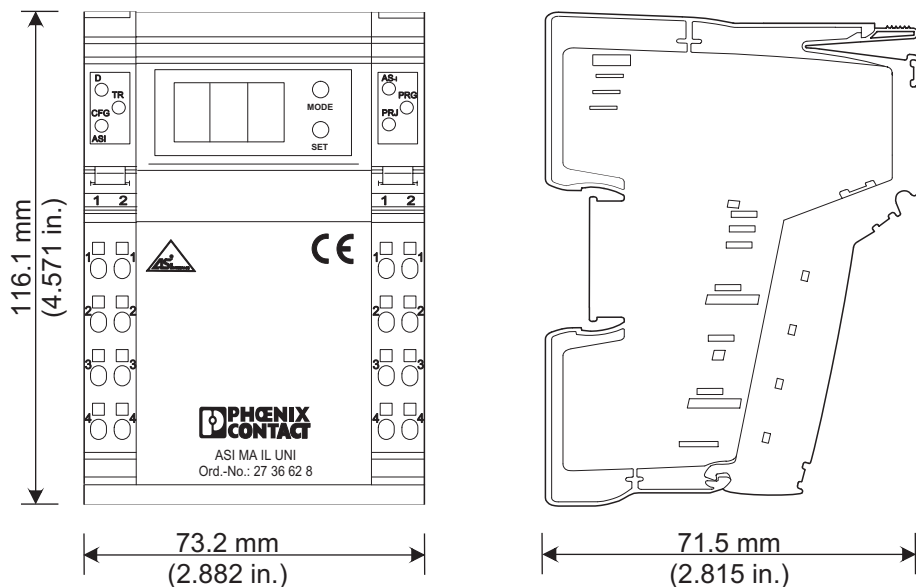

7041A007

Figure 9 Gateway dimensions

General Data	
Order designation	ASI MA IL UNI
Order No.	27 36 62 8
Housing dimensions (width x height x depth)	73.2 mm x 116.1 mm x 71.5 mm (2.882 x 4.571 x 2.815 in.)
Housing material	PA 6.6
Weight (typical)	210 g, approximately
Permissible temperature (operation)	-25°C to +55°C (-13°F to +131°F)
Permissible temperature (storage/transport)	-25°C to +85°C (-13°F to +185°F)
Permissible humidity (operation)	75% permanent, 85% occasionally
Permissible humidity (storage/transport with unused interfaces [standard packaging])	75% permanent, 85% occasionally

For a short period, slight condensation may appear on the outside of the housing if, for example, the terminal is brought into a closed room from a vehicle.

<b>General Data (Continued)</b>	
Permissible air pressure (operation)	80 kPa to 106 kPa (up to 2000 m [6562 ft.] above sea level)
Permissible air pressure (storage/transport)	70 kPa to 106 kPa (up to 3000 m [9843 ft.] above sea level)
Degree of protection	IP20 according to DIN 40050
Class of protection	Class 3 according to VDE 0106, IEC 60536
Free from substances that would hinder coating with paint or varnish	Yes

<b>Mechanical Requirements</b>	
Vibration test sinusoidal vibrations according to IEC 60068-2-6; EN 60068-2-6	2 g load, 2 hours in each space direction

<b>Power Supply</b>	
Communications power $U_L$	7.5 V
Current consumption at $U_L$	160 mA
Power consumption at $U_L$	1.2 W
AS-i voltage	26.5 V DC to 31.6 V DC
Current consumption of AS-i	200 mA
Insulation voltage	$\geq 500$ V AC

**ASI MA IL UNI**

<b>Programming Data</b>	
ID code	DF <sub>hex</sub> (223 <sub>dec</sub> )
Input address area	16 to 240 bits (can be set in increments of 32 bits)
Output address area	16 to 240 bits (can be set in increments of 32 bits)
PCP communication	Yes (1 word)
Register length	2/4/6/8/10/12/14/16 words Default: 10 words
Module error message on	AS-i voltage interrupt (can be deactivated)
Module error message on	AS-i configuration error (can be deactivated)

<b>Approvals</b>	
CE	Yes
AS-i certification	Yes

**Conformance With EMC Directive 89/336/EEC**

Conformance is only achieved if the gateway is connected to functional earth ground (FE).

**Noise Immunity Test According to EN 61000-6-2**

Electrostatic discharge (ESD)	EN 61000-4-2 IEC 61000-4-2	Criterion B 6 kV contact discharge 8 kV air discharge
Electromagnetic fields	EN 61000-4-3 IEC 61000-4-3	Criterion A Field strength: 10 V/m
Fast transients (burst)	EN 61000-4-4 IEC 61000-4-4	Criterion B Supply lines: 2 kV Signal/data lines: 2 kV
Conducted interference	EN 61000-4-6 IEC 61000-4-6	Criterion A, test voltage 7 V Criterion B, test voltage 10 V



The functional reliability of the gateway can be reduced by the influence of conducted interference caused by high-frequency fields.

**Noise Emission Test According to EN 61000-6-4**

Noise emission of housing	EN 55011	Class A
---------------------------	----------	---------

## ASI MA IL UNI

---

### Ordering Data

Description	Order Designation	Order No.
AS-Interface gateway for Inline	ASI MA IL UNI	27 36 62 8
"Configuring and Installing the AS-Interface Gateway for Inline" user manual	UM EN ASI MA IL UNI	26 99 67 1
AS-Interface system manual	ASI DOC SYSTEM UM E	26 98 56 2
"Configuring and Installing the INTERBUS Inline Product Range" user manual	IB IL SYS PRO UM E	27 43 04 8



Make sure you always use the latest documentation. It can be downloaded at [www.phoenixcontact.com](http://www.phoenixcontact.com).

Phoenix Contact GmbH & Co. KG  
 Flachsmarktstr. 8  
 32825 Blomberg  
 Germany



+49 - 52 35 - 30 0



+49 - 52 35 - 34 12 00



[www.phoenixcontact.com](http://www.phoenixcontact.com)



Worldwide Locations:

[www.phoenixcontact.com/salesnetwork](http://www.phoenixcontact.com/salesnetwork)



# SCATTERGOOD & JOHNSON LTD

ELECTRICAL ENGINEERING & FLUID CONTROL DISTRIBUTORS

Est.1899

At Scattergood & Johnson Ltd, we pride ourselves on being a technical distributor to specialist industries.

Working with a range of quality product suppliers across a number of specialist markets, we are not your average 'box shifter' - we are your technical and supply chain partner.

We fully support every product we sell - for free! Our internal team and external sales engineers can answer any product or application question, no matter the complexity.

Backing up this technical ability is a range of 50,000+ products available from stock for nationwide next day delivery (same day if required!), or you can collect what you need from any of our trade counters around the UK.

Select your specialist interest below to learn more about how we can help.

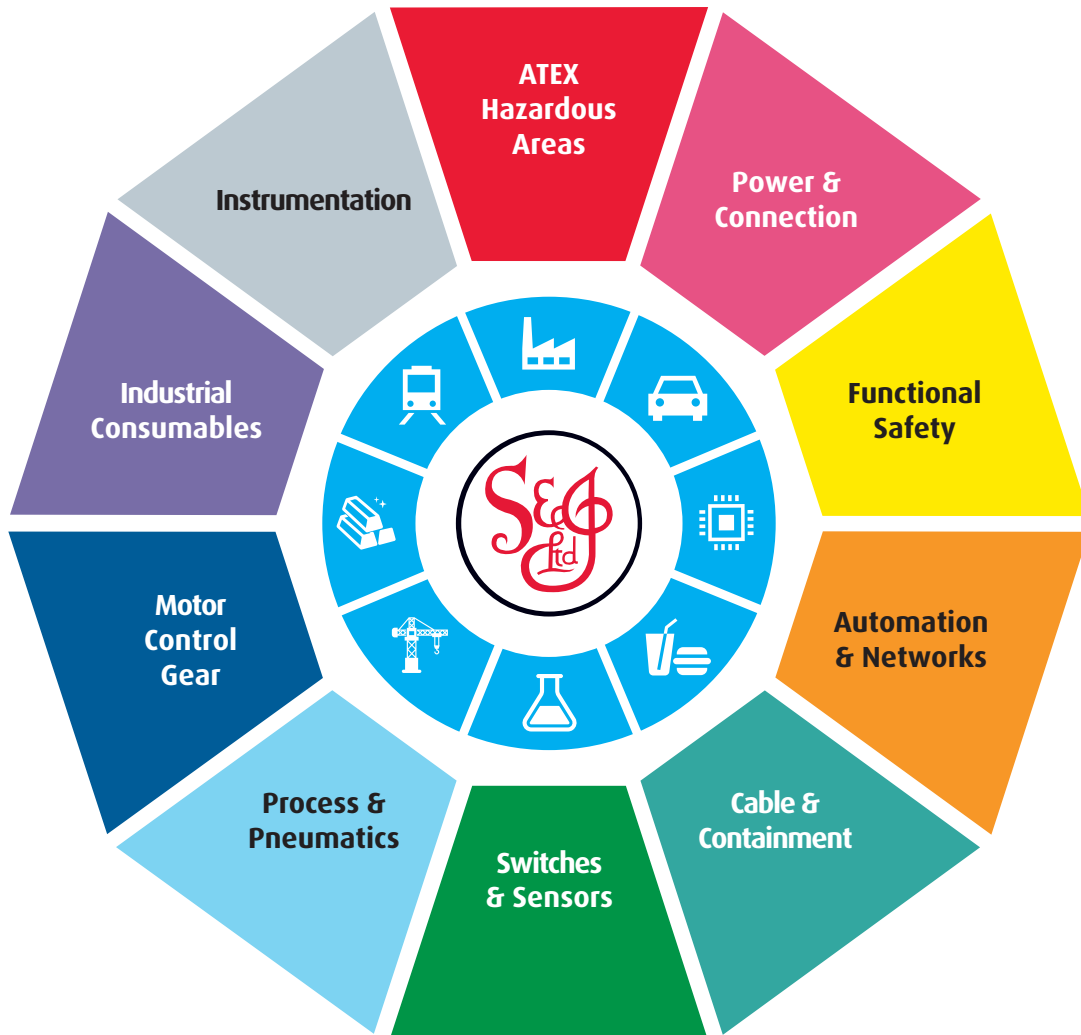

Online, In Branch and On the Road - Scattergood & Johnson Ltd, there when you need us.

# [www.scatts.co.uk](http://www.scatts.co.uk)