

Ethernet

ILB ETH 24 DI16 DIO16-2TX

Inline Block IO Module
for Ethernet With 16 Digital Inputs
and 16 Digital Inputs or Outputs

AUTOMATIONWORX

Data Sheet
7046_en_02

© PHOENIX CONTACT - 03/2007

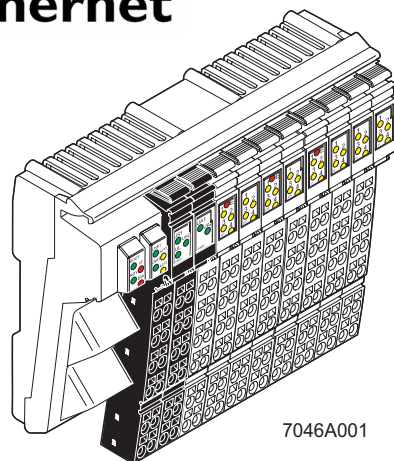

7046A001

1 Description

The ILB ETH 24 DI16 DIO16-2TX module is designed for use within an Ethernet network. It is used to acquire and output digital signals.

1.1 Ethernet Features

- 2 x Ethernet twisted pair according to 802.3u with auto negotiation, and auto crossover connected via an integrated managed 3-port switch (2 external ports, 1 internal port)
- Transmission rates of 10 Mbps and 100 Mbps
- IP parameter setting via BootP
- Software interface: Modbus/TCP or DDI (Device Driver Interface)
- Management via WEB and SNMP
- OPC server 2.14 support

1.2 Input Features

- Connections for 16 digital sensors
- Connection of sensors in 2 and 3-wire technology
- Maximum permissible load current per sensor: 125 mA
- Maximum permissible load current from the sensor supply: 2.0 A

1.3 Combined Input and Output Features

- Connections for 16 digital sensors/actuators
- Each single channel can only be used as an input or as an output
- Connection of sensors in 2 and 3-wire technology
- Maximum permissible load current per sensor: 125 mA
- Maximum permissible load current from the sensor supply: 2.0 A
- Connection of actuators in 2-wire technology
- Nominal current per output: 0.5 A
- Total current of all outputs: 8 A
- Short-circuit and overload protected outputs



The ILB ETH 24 DI16 DIO16-2TX module is designed for SELV operation according to DIN VDE 0805 / EN 60950 / IEC 60950.



Please refer to the "Mounting and Removing Inline Block IO Modules" application note (see "Ordering Data" on page 4).



Make sure you always use the latest documentation. It can be downloaded at www.download.phoenixcontact.com.
A conversion table is available on the Internet at www.download.phoenixcontact.com/general/7000_en_00.pdf.



For OPC server use an example configuration file can be downloaded at www.download.phoenixcontact.com.

Table of Contents

1	Description.....	1
1.1	Ethernet Features	1
1.2	Input Features	1
1.3	Combined Input and Output Features.....	1
2	Ordering Data	4
3	Technical Data.....	5
4	Internal Circuit Diagram.....	9
5	Relevant Notes	10
6	Local Diagnostic and Status Indicators	10
7	Connecting Ethernet, the Supply, and Actuators and Sensors	12
7.1	Connecting Ethernet	12
7.2	Connecting the Supply, Actuators and Sensors.....	13
7.3	Terminal Point Assignment of the Power Connectors (Connectors 1 and 2 in Figure 6).....	13
7.4	Terminal Point Assignment of the Input and Output Connectors (Connectors 3 and 6 in Figure 6 on page 13)	14
7.5	Terminal Point Assignment of the Input Connectors (Connectors 7 to 10 in Figure 6 on page 13).....	14
8	Connection Example	15
9	Startup	16
9.1	Default upon Delivery/Default Settings	16
9.2	Starting the Firmware.....	16
9.3	Sending BootP Requests.....	17
9.4	Reconfiguration Button.....	17
10.1	Calling Web-Based Management	17
10.2	Structure of the Web Pages	17
10.3	"IP Configuration" Menu	18
10.4	Password Protection	18
10.5	Firmware Update via WBM	19
10.6	Process Data Access via XML	19
10.7	XML File Structure	20
11	SNMP	21
11.1	MIBs.....	21
11.2	Traps.....	21
12	Monitoring Functions	22
12.1	Setting the Required Fault Response Mode	22
12.2	Process Data Watchdog/Process Data Monitoring	23
12.3	Fault Response Acknowledgement.....	24

13	Modbus/TCP Protocol	25
13.1	Modbus Connections	25
13.2	Modbus Interface	25
13.3	Modbus Conformity Classes	25
13.4	Modbus Function Codes	25
13.5	Modbus Table	25
13.6	Process Data Assignment (Modbus).....	26
14	Device Driver Interface (DDI)	27
14.1	Connection and Error Monitoring	27
14.2	Services for Process Data Monitoring.....	27
14.3	Services for Ethernet Connection Management	27
14.4	Structure of the DTI Area	27
14.5	Process Data Assignment (DDI)	28
15	Diagnostic Register	29
15.1	Status Register.....	29
15.2	I/O Diagnostic Register	29
15.3	NetFail Reason	29
16	Special Register	30
16.1	Modbus Connection Timeout	30
16.2	Process Data Watchdog Timeout	30
16.3	Fault Response Mode	30
16.4	Command Register	30

2 Ordering Data

Product

Description	Type	Order No.	Pcs./Pkt.
Inline Block IO module for Ethernet with 16 digital inputs and 16 digital outputs or outputs	ILB ETH 24 DI16 DIO16-2TX	2832962	1

Accessories: Ethernet

Description	Type	Order No.	Pcs./Pkt.
Gray RJ45 connector set for linear cable	FL PLUG RJ45 GR/2	2744856	2
Green RJ45 connector set for crossed cable	FL PLUG RJ45 GN/2	2744571	2
Double sheathed Ethernet cable	FL CAT5 HEAVY	2744814	1
Flexible Ethernet cable	FL CAT5 FLEX	2744830	1
Assembly tool for RJ45 connector	FL CRIMPTOOL	2744869	1



Matching dust protection covers and safety systems for RJ45 connections can be found in the product range of Reichle & De Massari/Switzerland.

Accessories: Software

Description	Type	Order No.	Pcs./Pkt.
Factory Manager, network management software	FL SWT	2831044	1



You can use **Factory Manager** for Ethernet network diagnostics as well as for firmware updates of the ILB ETH 24 DI16 DIO16-2TX module. However, it is not required for module startup.

INTERBUS OPC server CD-ROM with German and English product version 2.1x and online documentation. Additional language versions are available on request.	IBS OPC SERVER	2729127	1
--	----------------	---------	---

Accessories: Connectors as Replacement Item

Description	Type	Order No.	Pcs./Pkt.
Connector for the supply (color print)	ILB SCN-12-PWR IN-CP	2863164	5
Connector for digital 4-channel or 16-channel Inline input terminals, with color print	IB IL SCN-12-ICP	2727611	10

Accessories: Other

Description	Type	Order No.	Pcs./Pkt.
Recommended end clamp; placed both to the right and left of the module to secure it on the DIN rail	CLIPFIX 35-5	3022276	50

Documentation

Description	Type	Order No.	Pcs./Pkt.
"Mounting and Removing Inline Block IO Modules" application note	AH ILB INSTALLATION	9014931	1
"Firmware Updates for Devices Supporting TFTP Firmware Updates" application note	AH EN TFTP FIRMWARE UPDATE	7090	1
"Driver Reference Manual for G4-Based Controller Boards Using PC Bus and Ethernet" user manual	IBS PC SC SWD UM E	2745172	1

3 Technical Data

General Data	
Housing dimensions with connectors (width x height x depth)	156 mm x 55 mm x 141 mm
Weight	500 g (with connectors)
Operating mode	Process data mode with 4 bytes
Transmission speed	10 Mbps and 100 Mbps with auto negotiation and auto crossover
Type of sensor and actuator connection	2 and 3-wire technology

Housing Dimensions

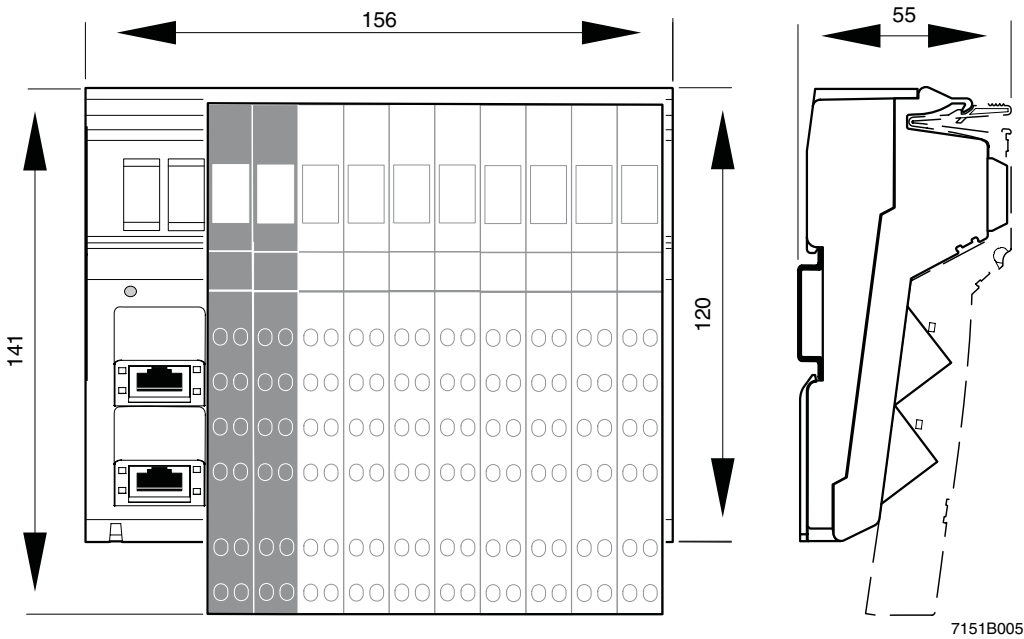

Figure 1 Housing dimensions of the module (dimensions in mm)

Ambient Conditions	
Regulations	Developed according to VDE 0160/EN 50178/IEC 62103, UL 508
Ambient temperature (operation)	-25°C to +60°C
Ambient temperature (storage/transport)	-25°C to +85°C
Humidity (operation/storage/transport)	10% to 95%, according to EN 61131-2
Air pressure (operation)	80 kPa to 108 kPa (up to 2000 m above sea level)
Air pressure (storage/transport)	66 kPa to 108 kPa (up to 3500 m above sea level)
Degree of protection according to IEC 60529	IP20
Class of protection	Class 3 according to VDE 0106/IEC 60536
Air and creepage distances	According to DIN VDE 0110/IEC 60664, IEC 60664A, DIN VDE 0160/EN 50178/IEC 62103
Housing material	Plastic, PVC-free, PBT, self-extinguishing (V0)
Pollution degree according to EN 60664-1/IEC 60664-1, EN 61131-2/IEC 61131-2	2; condensation not permitted during operation
Surge voltage class	II

Electrical Isolation/Isolation of the Voltage Areas**Test Distance**

Test Distance	Test Voltage
I/O / Logic	500 V AC, 50 Hz, 1 min
I/O / functional earth ground	500 V AC, 50 Hz, 1 min
Logic / functional earth ground	500 V AC, 50 Hz, 1 min
Ethernet interface signals / logic	1500 V rms, 50 Hz to 60 Hz, 1 min

Mechanical Requirements

Vibration test, sinusoidal vibrations according to EN 60068-2-6/IEC 60068-2-6	5g load, 2.5 hours in each space direction
Shock test according to EN 60068-2-27/IEC 60068-2-27	25g load for 11 ms, half sinusoidal wave, 3 shocks in each space direction and orientation
Broadband noise according to EN 60068-2-64/IEC 60068-2-64	0.78g load, 2.5 hours in each space direction

Conformance With EMC Directive 89/336/EEC**Noise Immunity Test According to EN 61000-6-2**

Electrostatic discharge (ESD)	EN 61000-4-2 IEC 61000-4-2	Criterion B 4 kV contact discharge 8 kV air discharge
Electromagnetic fields	EN 61000-4-3 IEC 61000-4-3	Criterion A Field strength: 10 V/m
Fast transients (burst)	EN 61000-4-4 IEC 61000-4-4	Criterion B Remote bus: 2 kV Power supply: 2 kV I/O cables: 2 kV Criterion A All interfaces: 1 kV
Surge voltage	EN 61000-4-5 IEC 61000-4-5	Criterion B DC supply lines: ± 0.5 kV/ ± 1.0 kV (symmetrical/asymmetrical) Signal lines: ± 1 kV/ ± 1 kV (symmetrical/asymmetrical)
Conducted interference	EN 61000-4-6 IEC 61000-4-6	Criterion A Test voltage 10 V

Noise Emission Test According to EN 61000-6-4

Noise emission of housing	EN 55011	Class A
---------------------------	----------	---------

Interface

Ethernet interface	2 x Ethernet twisted pair according to 802.3u via RJ45 connector; shielding directly connected to functional earth ground
--------------------	---

24 V Module Supply (Communications Power, Sensor and Actuator Supply; U_L , U_S and U_A)

Nominal value	24 V DC
Tolerance	-15%/+20% according to EN 61131-2
Ripple	$\pm 5\%$ according to EN 61131-2
Permissible range	19.2 V DC to 30.0 V DC
Current consumption at U_L	70 mA
Current consumption at U_{S1} and U_{S2}	2 x 2 A
Current consumption at U_{A1} and U_{A2}	2 x 4 A
Safety equipment for communications power	Surge protection and protection against polarity reversal
Safety equipment for sensor supply	Surge, overload and short-circuit protection
Safety equipment for actuator supply	Surge protection
Connection	Via power connectors

Digital Outputs

Number	16 (freely selectable)
Connection method for actuators	2-wire technology
Nominal output voltage U_{OUT}	24 V DC
Differential voltage at I_{nom}	≤ 1 V
Nominal current I_{nom} per channel	0.5 A
Total current	2 x 4 A
Protection	Short-circuit and overload protection
Nominal load	
Ohmic	48 Ω / 12 W
Lamp	12 W
Inductive	12 VA (1.2 H, 50 Ω)
Switching frequency with nominal inductive load	0.5 Hz (1.2 H, 50 Ω), maximum
Overload response	Auto restart
Response with inductive overload	Output may be damaged
Reverse voltage protection against short pulses	Protected against reverse voltages
Resistance to permanently applied reverse voltages	Protected against reverse voltages, permissible current 2 A, maximum
Response upon power down	The output follows the supply voltage without delay.
Limitation of the voltage induced on circuit interruption	-41.0 V
One-time unsolicited energy	1 J, maximum
Protective circuit type	Integrated free running circuit in the output chip
Overcurrent shutdown	0.7 A, minimum
Maximum output current when switched off	10 μ A



When not loaded, a voltage can be measured even at an output that is not set.

Error message to the higher-level control system	Short circuit/overload of outputs
--	-----------------------------------

Digital Inputs

Number	32 (16 permanent, 16 freely selectable)
Connection method for sensors	2 and 3-wire technology
Input design	According to EN 61131-2 Type 1
Definition of switching thresholds	
Maximum low-level voltage	$U_{Lmax} < 5$ V
Minimum high-level voltage	$U_{Hmin} > 15$ V
Common potentials	Sensor supply U_S , ground
Nominal input voltage U_{IN}	24 V DC
Permissible range	-30 V < U_{IN} < +30 V DC
Nominal input current for U_{IN}	5 mA, typical
Current flow	Linear in the range 1 V < U_{IN} < 30 V
Delay time	≤ 500 μ s
Permissible cable length to the sensor	100 m
Use of AC sensors	AC sensors in the voltage range < U_{IN} are limited in application
Error message to the higher-level control system	Sensor supply not present Short circuit/overload of sensor supply

Power Dissipation

Formula to Calculate the Power Dissipation of the Electronics

$$P_{TOT} = 1.68 \text{ W} + (I_{S36}^2 + I_{S710}^2) \times 0.06 \Omega + \sum_{i=1}^n (0.129 \text{ W} + I_{Li}^2 \times 0.28 \Omega + I_{Li} \times 0.35 \text{ V}) + \sum_{j=1}^m 0.125 \text{ W}$$

Where

- P_{TOT} Total power dissipation of the module
- I_{S36} Current from the sensor supply at slots 3 to 6
- I_{S710} Current from the sensor supply at slots 7 to 10
- i Continuous index
- n Number of set outputs (n = 1 to 16)
- I_{Li} Load current of output i
- j Continuous index
- m Number of set inputs (n = 1 to 32)

Limitation of Simultaneity

No limitation of simultaneity, derating

Derating

Ambient Temperature (T_A)

Total Current (I_{tot})

Outputs, Connectors 3 to 6

-25°C to +30°C

8 A

+30°C to +60°C

8 A - ((T_A - 30°C) x 0.2 A/°C)

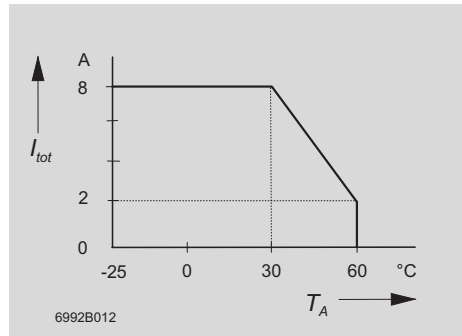

Sensor Supply, Connectors 3 to 6

-25°C to +30°C

2 A

+30°C to +60°C

2 A - ((T_A - 30°C) x 0.05 A/°C)

Sensor Supply, Connectors 7 to 10

-25°C to +30°C

2 A

+30°C to +60°C

2 A - ((T_A - 30°C) x 0.05 A/°C)

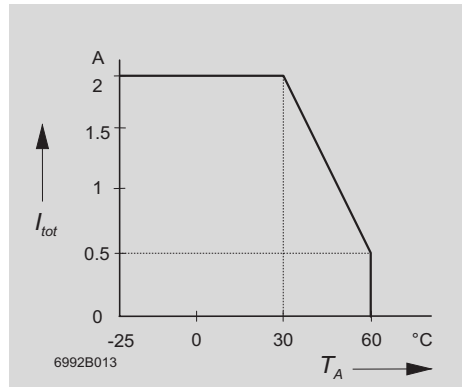

Approvals

For the latest approvals, please visit www.download.phoenixcontact.com.

4 Internal Circuit Diagram

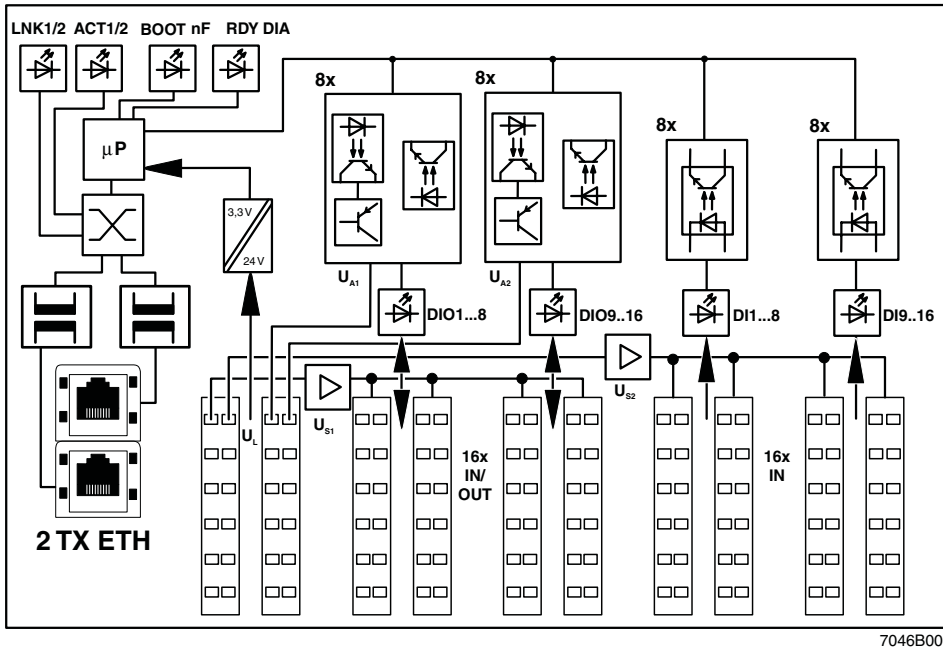

7046B004

Figure 2 Internal wiring of the terminal points

Key:

- LED
- Microprocessor
- Switch
- Transmitter

- Power supply unit with electrical isolation
- Optocoupler
- Short-circuit-proof output
- Short-circuit-proof sensor supply

5 Relevant Notes



Shielding

The shielding ground of the connected twisted pair cables is electrically connected with FE. When connecting network segments, avoid ground loops, potential transfers, and equipotential bonding currents using the braided shield.



Electrostatic discharge

The module contains components that can be damaged or destroyed by electrostatic discharge. When handling this module, observe the necessary safety precautions against electrostatic discharge (ESD) in accordance with EN 61340-5-1 and EN 61340-5-2.



Housing
 Only authorized Phoenix Contact personnel are permitted to open the housing.

6 Local Diagnostic and Status Indicators

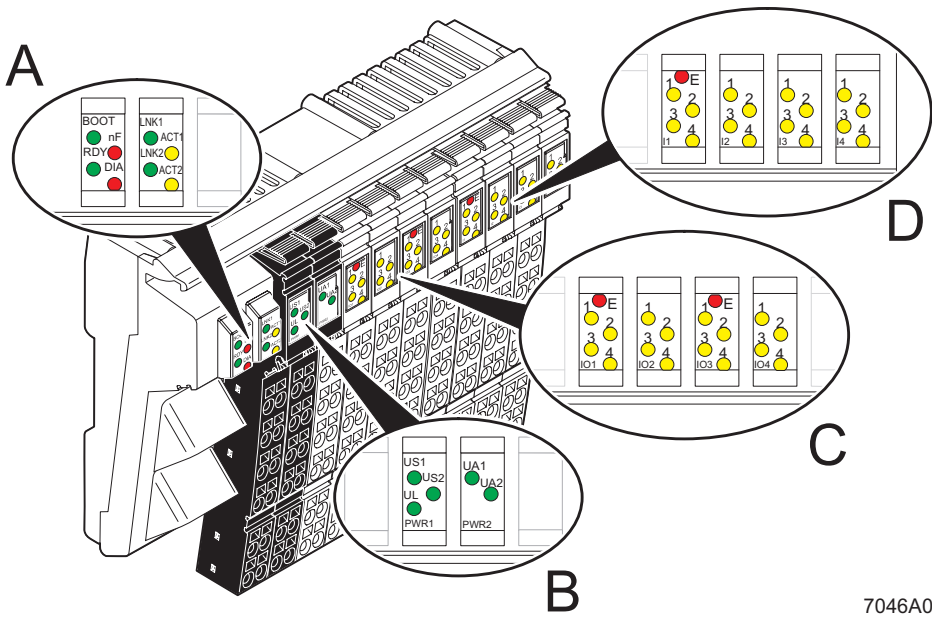

7046A002

Figure 3 Diagnostic and status indicators of the ILB ETH 24 DI16 DIO16-2TX module

Designation	Color		Meaning
A: Module and Ethernet			
BOOT	Green	OFF	Boot loader inactive / firmware successfully started
		Flashing	Waiting for BootP reply
		ON	Start firmware
RDY	Green	OFF	Firmware not active
		Flashing	Firmware ready to operate
		ON	Connection to a process data client established
nF	Red	OFF	No network error
		ON	Network error occurred; connection monitoring, for example, has tripped or an error occurred during the firmware update.
		Flashing	Firmware error
		Flashing together with DIA	Hardware watchdog triggered
DIA	Red	OFF	There is no module diagnostics.
		ON	There is module diagnostics. (A bit is set in the diagnostic register.)
		Flashing	Firmware error
		Flashing together with nF	Hardware watchdog triggered
LNK1/2	Green	OFF	No connection established via port 1/2
		ON	Connection via Ethernet to a module via port 1/2 established
ACT1/2	Yellow	OFF	No transmission or reception of Ethernet telegrams at port 1/2
		ON	Transmission or reception of Ethernet telegrams at port 1/2
B: PWR			
US1/2	Green	ON	Sensor supply 1/2 present
		OFF	Sensor supply 1/2 not present
UL	Green	ON	24 V communications power present
		OFF	24 V communications power not present
UA1/2	Green	ON	Actuator supply 1/2 present
		OFF	Actuator supply 1/2 not present
C: IN/OUT, Each Connector			
E	Red	ON	Short circuit or overload of the outputs
		OFF	No output error
1 to 4	Yellow	ON	Input/output active
		OFF	Input/output not active
D: IN, Each Connector			
E	Red	ON	Short circuit or overload of one of the sensor supplies
		OFF	No sensor supply error
1 to 4	Yellow	ON	Input active
		OFF	Input not active



If the error LED (E) of a group of eight outputs (e.g., connector 3/4 or connector 5/6) lights up this indicates that a short circuit or overload is present at one or more of the outputs in this group.

7 Connecting Ethernet, the Supply, and Actuators and Sensors

7.1 Connecting Ethernet

By default upon delivery, the Ethernet connections have been set to auto negotiation with auto crossover.

If a port is set to fixed transmission parameters (speed, duplex mode), auto crossover is deactivated. In this case the port acts like a switch port (MDI-X). The pin assignment is specified accordingly. The module must be connected to termination devices using a 1:1 cable and to other configuration devices using a cross-over cable.



For further information on Ethernet cabling, please refer to www.iaona-eu.com.

Connect Ethernet to the module using an 8-pos. RJ45 connector. For the pin assignment of the RJ45 female connector, please refer to the following table:

Pin	Assignment
1	RD+ (receive data +)
2	RD- (receive data -)
3	TD+ (transmit data +)
4	Reserved
5	Reserved
6	TD- (transmit data -)
7	Reserved
8	Reserved

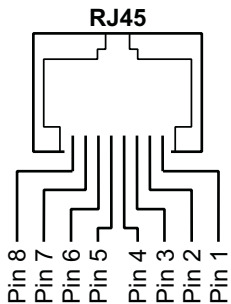
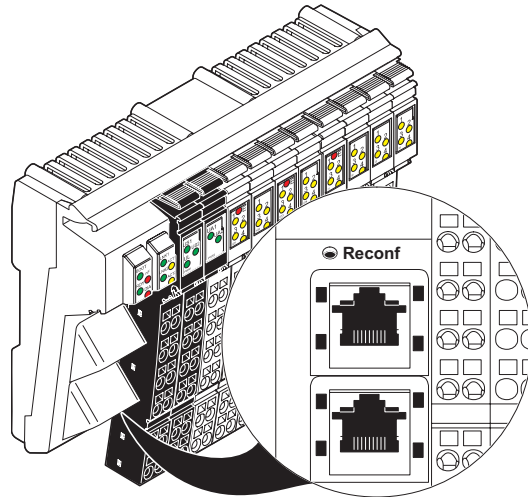

Figure 4 Pin assignment of the RJ45 female connector



7046A006

Figure 5 8-pos. RJ45 female connectors



For further information on the reconfiguration button, please refer to page 16.

7.2 Connecting the Supply, Actuators and Sensors

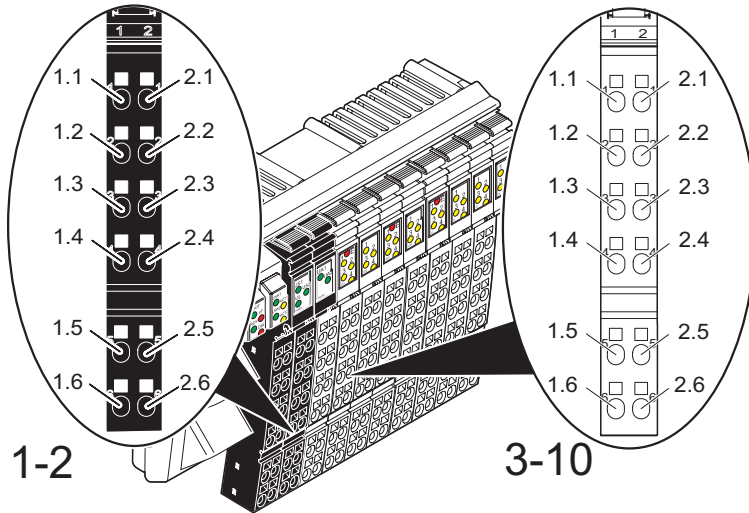

7046A003

Figure 6 Terminal point assignment of the Inline connectors

7.3 Terminal Point Assignment of the Power Connectors (Connectors 1 and 2 in Figure 6)

Terminal Point	Assignment	Terminal Point	Assignment
Connector 1 (PWR 1)			
1.1	24 V sensor supply U_{S1}	2.1	24 V sensor supply U_{S2}
1.2	24 V communications power U_L	2.2	24 V communications power U_L
1.3	GND	2.3	GND
1.4	FE	2.4	FE
1.5	24 V communications power U_L	2.5	24 V communications power U_L
1.6	GND	2.6	GND
Connector 2 (PWR 2)			
1.1	Actuator supply U_{A1}	2.1	Actuator supply U_{A2}
1.2	24 V communications power U_L	2.2	24 V communications power U_L
1.3	GND	2.3	GND
1.4	FE	2.4	FE
1.5	24 V communications power U_L	2.5	24 V communications power U_L
1.6	GND	2.6	GND



The terminal points can have a total current of 8 A per terminal point. The maximum current carrying capacity of 8 A must not be exceeded. If the total output current in your application is > 8 A, supply the module via a minimum of two terminal points connected in parallel.



The supply points have the same ground potential. All ground supplies on a module are electrically connected with one another. The communications power is also electrically connected via all contacts. In this way, it can supply all potentials with just one supply without the need for additional terminals, see "Connection Example" on page 15.

7.4 Terminal Point Assignment of the Input and Output Connectors (Connectors 3 and 6 in Figure 6 on page 13)

Terminal Point				Assignment
Connector 3 (IO1)	Connector 4 (IO2)	Connector 5 (IO3)	Connector 6 (IO4)	
1.1, 2.1	1.1, 2.1	1.1, 2.1	1.1, 2.1	Signal input (IN) and output (OUT)
1.2, 2.2	1.2, 2.2	1.2, 2.2	1.2, 2.2	Sensor voltage U_{I1} for 2 and 3-wire termination
1.3, 2.3	1.3, 2.3	1.3, 2.3	1.3, 2.3	Ground contact (GND) for 3-wire termination
1.4, 2.4	1.4, 2.4	1.4, 2.4	1.4, 2.4	Signal input (IN) and output (OUT)
1.5, 2.5	1.5, 2.5	1.5, 2.5	1.5, 2.5	Initiator supply U_{I1} for 2 and 3-wire termination
1.6, 2.6	1.6, 2.6	1.6, 2.6	1.6, 2.6	Ground contact (GND) for 3-wire termination



Each channel on the connectors three to six can either be used as input or output. A configuration is not required.



If a channel is used as input, this input must **not** be set as an output.

7.5 Terminal Point Assignment of the Input Connectors (Connectors 7 to 10 in Figure 6 on page 13)

Terminal Point				Assignment
Connector 7 (I1)	Connector 8 (I2)	Connector 9 (I3)	Connector 10 (I4)	
1.1, 2.1	1.1, 2.1	1.1, 2.1	1.1, 2.1	Signal input (IN)
1.2, 2.2	1.2, 2.2	1.2, 2.2	1.2, 2.2	Sensor voltage U_{IS} for 2 and 3-wire termination
1.3, 2.3	1.3, 2.3	1.3, 2.3	1.3, 2.3	Ground contact (GND) for 3-wire termination
1.4, 2.4	1.4, 2.4	1.4, 2.4	1.4, 2.4	Signal input (IN)
1.5, 2.5	1.5, 2.5	1.5, 2.5	1.5, 2.5	Initiator supply U_{I2} for 2 and 3-wire termination
1.6, 2.6	1.6, 2.6	1.6, 2.6	1.6, 2.6	Ground contact (GND) for 3-wire termination

8 Connection Example

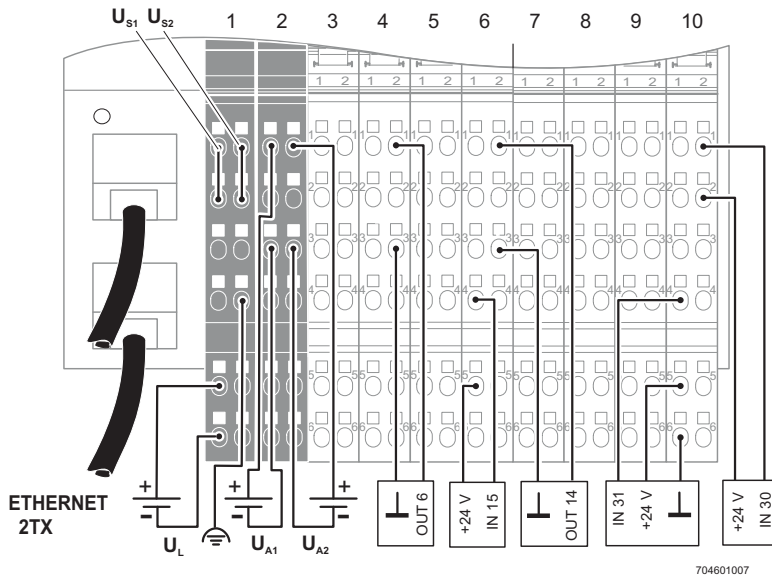

Figure 7 Connection example



The numbers above the module illustration identify the connector slots.



The module has an FE spring (metal clip) on the bottom of the electronics base. This spring creates an electrical connection to the DIN rail. Use grounding terminals to connect the DIN rail to protective earth ground. The module is grounded when it is snapped onto the DIN rail. To ensure reliable functional earth grounding of the module even when the DIN rail is dirty or the metal clip is damaged, Phoenix Contact also recommends grounding the module via one of the FE terminal points.

9 Startup

9.1 Default upon Delivery/Default Settings

By default upon delivery, the following functions and features are available:

- For SNMP and web-based management the password is "private".
- IP configuration

IP address:	0.0.0.0
Subnet mask:	0.0.0.0
Default gateway:	0.0.0.0
BootP requests:	Enable
- Software update

Software update on next reboot:	Disable
TFTP server IP address:	0.0.0.0
Downloadable file name:	-
- Port configuration

Mode of port 1:	Auto negotiation
Mode of port 2:	Auto negotiation
- SNMP configuration

Name of device:	Inline Block I/O
Description:	ILB with 16 IN and 16 IN/OUT
Physical location:	Unknown
Contact:	Unknown
- Trap configuration

Sending traps:	Disable
Trap manager IP address 1 to 5:	0.0.0.0
- Services

HW watchdog:	Enable
--------------	--------
- Process data monitoring

Process data watchdog timeout:	500 ms
Fault response mode:	Reset fault mode (default)



By default, the ILB ETH 24 DI16 DIO16-2TX module has no valid IP parameters.

9.2 Starting the Firmware

After you have applied voltage to the module the firmware is started. The following LED sequence is shown:

LED	Meaning
BOOT flashing	Boot Loader is started BootP requests are sent
BOOT ON	Firmware is extracted
BOOT and RDY ON	Firmware is started
RDY flashing	Operation

9.3 Sending BootP Requests

Initial startup:

During initial startup, the module transmits a BootP request without interruption until it receives a valid IP address. The requests are transmitted at varying intervals (2 s, 4 s, 8 s, 2 s, 4 s, etc.) so that the network is not loaded unnecessarily.

If valid IP parameters are received, they are saved as configuration data by the module.

Further restarts:

If the module already has valid configuration data and BootP is not disabled, it only transmits three more BootP requests on a restart. If it receives a BootP reply, the new parameters are saved. If the module does not receive a reply, it starts with the previous configuration. If BootP is disabled and a valid configuration is available, the module starts immediately.



For presetting the IP address via BootP, you can use Factory Manager (see "Ordering Data" on page 4) or any BootP server available.

9.4 Reconfiguration Button

By modifying the network parameters you can block your access to the module via Ethernet. If, for example, BootP is disabled and the user forgets the IP address set, the reconfiguration button can be used to access the module again.

If the reconfiguration button is pressed during power-on, all permanently stored parameters are reset to the default upon delivery. The reconfiguration button must be pressed until the BOOT LED and the RDY LED are on. As soon as the reconfiguration button has been released, the module starts with the default parameters.

10 Web-Based Management (WBM)

The ILB ETH 24 DI16 DIO16-2TX module has a web server, which generates the required pages for web-based management and, depending on the requirements of the user, sends them to "Factory Manager" or a standard web browser.

Web-based management can be used to access static information (e.g., technical data, MAC address) or dynamic information (e.g., IP address, status information) or to change the configuration (password-protected).

10.1 Calling Web-Based Management

The ILB ETH 24 DI16 DIO16-2TX web server can be addressed using the IP address if configured correspondingly.

The module homepage is accessed by entering the URL (<http://<ip address>>) in the address line of your browser.

Example: <http://192.168.2.81>

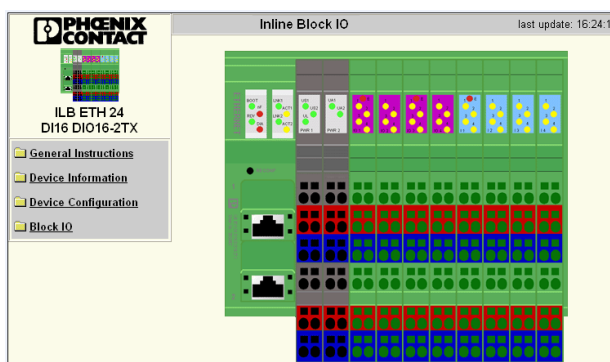

Figure 8 WBM homepage

10.2 Structure of the Web Pages

The module web pages are divided into two parts, with the navigation tree and the relevant submenus on the left-hand side, and the corresponding information displayed on the right-hand side.

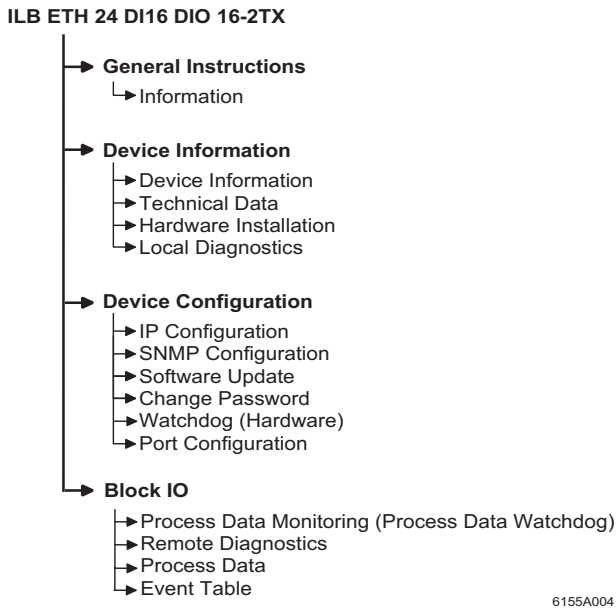

Figure 9 Structure of the web pages

10.3 "IP Configuration" Menu

Figure 10 shows the set IP parameters and addressing mechanism. To change the IP parameters via the WBM, "BootP Request" must be set to "Disable" or the module's BootP requests must not be answered, no BootP server must be activated in the network.

IP Configuration	
IP Address	<input type="text" value="192.168.2.81"/>
Subnet Mask	<input type="text" value="255.255.255.0"/>
Default-Gateway	<input type="text" value="0.0.0.0"/>
<i>Please enter IP Address, Subnet Mask and Gateway Address in dotted decimal notation (e.g., 172.16.16.230). The changes will take effect after the reboot of the ILB ETH 24 DI16 DIO16-2TX.</i>	
Enter Password	<input type="password"/> <input type="button" value="Reboot"/>
BootP Requests	<input checked="" type="radio"/> Enable <input type="radio"/> Disable
<i>Before disabling automatic BootP setting, be sure to record the current IP address. You will need the current IP address if you want to re-enable BootP setting of the IP address. If you forget the IP address, the only way is to delete the whole configuration over the Reconf-Button.</i>	
Enter Password	<input type="password"/> <input type="button" value="Apply"/>

Figure 10 "IP Configuration" menu

10.4 Password Protection

All status changes to the module are only possible after entering a password. The password can be changed at any time. Your unique password must be between four and twelve characters long (note that the password is case-sensitive). By default upon delivery, the password is "private". The password for the web is the same as for the SNMP read and write access.



Forgetting the password requires resetting the entire configuration using the reconfiguration button in order to be able to access the module again.

10.5 Firmware Update via WBM

The following steps must be carried out when executing a firmware update via WBM:

- In WBM click on "Device Configuration" and then "Software Update". Enter the IP address of the TFTP server in the "TFTP Server IP Address" field. Then enter the file name of the firmware and the path name, if necessary, in the "Downloadable File Name" field. In the "Software Update on Next Reboot" field, click on "Enable".
- Enter your password and click "Apply" to execute a reboot at a later time; click on "Apply and Reboot" for the update to take effect immediately.
- Check execution of the update. After "Apply and Reboot" the browser automatically updates the web pages and displays the result in the "TFTP Update Status" field. After successful update and initial firmware start "Firmware Update was successfully executed" is displayed. In the event of an error during downloading the corresponding error message is indicated. The device indicates this error by means of the BOOT, RDY and NF LED combination. A restart repeats the downloading process. Activating "Disable" in the "Software Update on Next Reboot" field allows for update abortion and starting the previous firmware again.



If BootP is set to "Enable" and a reply with values for "TFTP Server IP Address" and "Downloadable File Name" is received, the entries done in WBM are overwritten with these specifications. After restart the values accepted are displayed in WBM.



In the event of an error during flash programming (e.g., voltage interrupt) the device can only be restarted by repeating the update. The device indicates this by means of the BOOT and NF LED combination. The device starts the update automatically after a restart. Access to WBM is no longer possible.



An application note for TFTP download using Factory Manager (AH EN TFTP FIRMWARE UPDATE) can be found at www.download.phoenixcontact.com.

Software Update	
TFTP Server IP Address	TFTP:// <input type="text" value="192.168.2.10"/>
Downloadable File Name	<input type="text" value="ilb_eth_di16_dio16_2tx_v"/>
Software Update on Next Reboot	<input type="radio"/> Enable <input checked="" type="radio"/> Disable
TFTP Update Status	Firmware Update was successfully executed.
<p><i>If the software update status is set to enable the ILB ETH 24 DI16 DIO16-2TX will try to load new software within the next reboot. Press the apply button to change the software update status. The settings will take effect after the next reboot of the ILB ETH 24 DI16 DIO16-2TX.</i></p>	
Enter password <input type="text"/>	<input type="button" value="Apply"/> <input type="button" value="Apply and Reboot"/>

Figure 11 "Software Update" menu

10.6 Process Data Access via XML

The web server of the ILB ETH 24 DI16 DIO16-2TX offers the possibility to access the process data via a web page in XML format.

You can access the web pages via a standard web browser. For calling the XML pages with the process data enter the address in the following format in the address line of the browser:

"http:// <IP address>/processdata.xml".

10.7 XML File Structure

The XML file contains different data areas:

ILB_STATION

Frame for the entire XML file. The obligatory elements of this frame are ILB_BUS_TERMINAL and ILB_BUS.

ILB_BUS_TERMINAL

This data area contains information about the module. Belonging to this data area:

TERMINAL_TYPE

This area contains the module designation, i.e., always ILB ETH 24 DI16 DIO16-2TX.

NAME

Contains the user-specific station names. The station name can be modified via SNMP or WBM.

IP_ADDRESS

Contains the IP address of the station.

GROUP_NUMBER

2: DIO and DI

DIAGNOSTIC_REGISTER

Contains the module status represented by all bits of the I/O diagnostic register.

ILB_BUS

Frame for the existing groups.

ILB_GROUP

Frame for the data of an individual group.

GROUP_TYPE

Contains the terminal type. Possible types are DI and DIO.

PD_CHANNELS

Number of process data channels in a group. For digital modules the number of channels is equal to the number of supported bits. Always 16 bits with this module.

PD_WORDS

Number of process data words in a group. Always one process data word with this module.

PD_IN

This area is used by all group<s that use input data. The number of process data words depends on the group. Always one process data word with this module.

PD OUT

This area is used by all terminals with output data. The use of bits is identical with the that in "PD_IN".

```

<?xml version="1.0" encoding="ISO-8859-1" ?>
<IDOCTYPE ILB_STATION (View Source for full doctype...)>
- <ILB_STATION>
  - <ILB_BUS_TERMINAL>
    <TERMINAL_TYPE>ILB ETH 24 DI16 DIO16-2TX</TERMINAL_TYPE>
    <NAME>Inline Block IO</NAME>
    <IP_ADDRESS>172.16.16.1</IP_ADDRESS>
    <GROUP_NUMBER>2</GROUP_NUMBER>
    <DIAGNOSTIC_REGISTER>0</DIAGNOSTIC_REGISTER>
  </ILB_BUS_TERMINAL>
  - <ILB_BUS>
    - <ILB_GROUP number="1">
      <GROUP_TYPE>DIO</GROUP_TYPE>
      <PD_CHANNELS>16</PD_CHANNELS>
      <PD_WORDS>1</PD_WORDS>
      <!-- Io1-Io4 IN -->
      <PD_IN word="1">0</PD_IN>
      <!-- Io1-Io4 OUT -->
      <PD_OUT word="1">0</PD_OUT>
    </ILB_GROUP>
    - <ILB_GROUP number="2">
      <GROUP_TYPE>DI</GROUP_TYPE>
      <PD_CHANNELS>16</PD_CHANNELS>
      <PD_WORDS>1</PD_WORDS>
      <!-- I1-I4 IN -->
      <PD_IN word="1">0</PD_IN>
    </ILB_GROUP>
  </ILB_BUS>
</ILB_STATION>

```

← Station data
 ← I/O diagnostic register
 ← DIO input data
 ← DIO output data
 ← DI input data

Figure 12 Screen for XML data

11 SNMP

The ILB ETH 24 DI16 DIO16-2TX module supports SNMP v1 and v2c.

11.1 MIBs

The module supports the following MIBs:

- MIB II defined by RFC 1213
- ILB-ETH-24-MIB in version 1.0

For the object descriptions, please refer to the ASN1 descriptions of this product. It can be downloaded at www.download.phoenixcontact.com.

The password for read access is "public" and cannot be modified. By default upon delivery, the password for read/write access is "private" and can be modified at any time. The same password is used for the web interface, see page 18.

11.2 Traps

The ILB ETH 24 DI16 DIO16-2TX module supports the following traps:

- Cold Start - is transmitted with every restart of the module in version v1 and V2c.
- Authentication - wrong password for SNMP access

12 Monitoring Functions

Monitoring functions with different features are available for monitoring Ethernet communication.

- Process data watchdog (process data monitoring)
- Connection monitoring for Modbus (see "Modbus Connection Timeout" on page 30) and DTI (see "Connection and Error Monitoring" on page 27).

There are monitoring functions according to the features/functions that need to be monitored. According to the application requirements the appropriate monitoring function can be activated. By default upon delivery, process data watchdog is activated.

Monitoring Mechanism	Monitoring ...			
	... the Client Application	... the Individual Channels	... the Ethernet Connection	... Process Data Exchange
Process data watchdog (process data monitoring)	X	–	X	X
Connection monitoring for Modbus and DTI	X	X	X	–

In the event of an error the system reacts with a fault response. The user determines the required fault response mode.

12.1 Setting the Required Fault Response Mode

The required fault response mode can be set via web-based management by writing to Modbus register 2002, using DTI byte address 4004, or via the "ETH_SetNet FailMode" function. The following fault response modes are available:

Fault Response Mode	Value	Function
Reset fault mode (default)	1	The digital outputs are set to "0".
Standard fault mode	0	All outputs are set to "0".
Hold last state mode	2	All outputs retain their last value.



As this module does not have analog outputs, the behavior in reset fault mode and standard fault mode is identical.

12.2 Process Data Watchdog/Process Data Monitoring



By default upon delivery, the process data watchdog is activated with 500 ms timeout.

Process Data Monitoring	
Fault Response Mode	<input checked="" type="radio"/> Reset Fault Mode (default) <input type="radio"/> Standard Fault Mode <input type="radio"/> Hold Last State Mode
Process Data Watchdog Timeout	500 ms
<i>The time is indicated in milliseconds and ranges from 200 ms to 65,000 ms. A value of 0 ms disables the Process OUT Data Monitoring.</i>	
Enter password	<input type="text"/> <input type="button" value="Apply"/>
Network Failure	
Status	No network failure (nF) occurred.
Enter password	<input type="text"/> <input type="button" value="Confirm"/>

Figure 13 Configuring process data monitoring in the WEB

Process Data Watchdog Function

A process data watchdog is integrated into the ILB ETH 24 DI16 DIO16-2TX module to avoid uncontrolled setting/resetting of the I/O station outputs in the event of an error.

If outputs of the stations are set, ensure access of the controlling process to the station. In the event of an error, e.g., network line interrupted or function error in the controlling process, the module can react appropriately. By default upon delivery, the watchdog is activated with 500 ms timeout. The first write process activates the process data watchdog. The next write process is expected during timeout (default: 500 ms). During error-free operation, the write process is performed during timeout and the watchdog is restarted (triggered).



Reading calls do not trigger the process data watchdog.

NET FAIL: If there is no triggering during timeout, an error occurred. Two responses follow:

- The selected fault response mode is executed.
- The NetFail signal is set (the Net Fail LED is red).

The reason for setting the NetFail signal is listed in the reason code.

For safety reasons, the user cannot stop the watchdog once it has been activated. In case the user terminates the controlling application, there is no watchdog triggering; when timeout has expired, the NetFail signal is set and the selected fault response mode is executed. After the watchdog has performed its task, the outputs are only enabled again after acknowledgment.



When the error is acknowledged, the watchdog is restarted. This means that it must be triggered during timeout, otherwise an error is detected again.

Configuration of the Process Data Watchdog



Timeout can only be changed if the watchdog is in "INIT" state. The "INIT" state is present:

- After power-up, as long as process data exchange has not taken place
- In case of timeout and if fault response has been activated and if NetFail has not yet been acknowledged

Process data watchdog timeout can be configured from 200 ms to 65000 ms. Timeout can be set using the web-based management, by writing to Modbus register 2000, or using DTI byte address 4000.

Deactivating the Process Data Watchdog

The process data watchdog can only be deactivated if it is in "INIT" state. For deactivation, the timeout value is set to "zero".

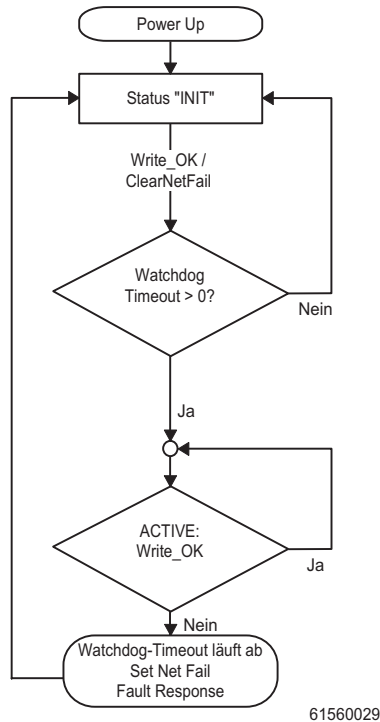

Figure 14 Status diagram of the process data watchdog

12.3 Fault Response Acknowledgement

The NetFail signal can be acknowledged using the web-based management, by writing command 0x0002 to the command register (Modbus register 2006 or DTI byte address 4012), or using the "ETH_ClrNet FailStatus" function.

Reasons for Fault Response

The web-based management, Modbus register 6, DTI byte address 12, or the "ETH_GetNet FailStatus" service can be used to request the reasons for fault response mode.

Possible Reasons:

DDI_NF_TASK_CREAT_ERR 0x0001
/* Error when starting a task */

DDI_NF_LISTENER_ERR 0x0002
/* Listener task error */

DDI_NF_RECEIVER_ERR 0x0003
/* Receiver task error */

DDI_NF_ACCEPT_ERR 0x0004
/* Accept function error */

DDI_NF_ECHO_SERVER_ERR 0x0005
/* Echo server task error */

DDI_NF_HOST_CONTROLLER_ERR 0x0006
/* Host controller task error */

DDI_NF_DTI_TIMEOUT 0x0007
/* DTI timeout occurred */

DDI_NF_HOST_TIMEOUT 0x0008
/* Host timeout occurred */

DDI_NF_USER_TEST 0x0009
/* NetFail set by user */

DDI_NF_CONN_ABORT 0x000A
/* Connection aborted */

DDI_NF_INIT_ERR 0x000B
/* Initialization error */

DDI_NF_DTI_WATCHDOG 0x000C
/* Process data watchdog triggered */

DDI_NF_MBUS_TIMEOUT 0x000D
/* Modbus timeout occurred */

13 Modbus/TCP Protocol

The module supports a Modbus/TCP server with the following features:

13.1 Modbus Connections

The module supports up to eight connections at the same time. In this way, a connection can quickly be re-established. This implies that the client can successfully restore an interrupted Modbus connection.

13.2 Modbus Interface

The Modbus interface according to the standard port 502 supports Modbus communication via the ILB ETH 24 DI16 DIO16-2TX module.

13.3 Modbus Conformity Classes

The ILB ETH 24 DI16 DIO16-2TX module supports Modbus conformity classes 0 and 1.

13.5 Modbus Table

	Modbus Register Table (16-Bit Words)	Modbus Input Discretes Table (Bits)	Modbus Coil Table	Access	Function
Process data	0	0-15	–	Read only	Digital inputs (DIO)
	1	16-32	–	Read only	Digital inputs (DI)
	2	–	0-15	Read/write	Digital outputs
	3	–	–	Read only	Reserved
Diagnostics	4	–	–	Read only	Status register
	5	–	–	Read only	I/O diagnostic register
	6	–	–	Read only	NetFail reason
	7	–	–	Read only	IBS diagnostic register (for compatibility with FL IL 24 BK)
	8	–	–	Read only	IBS para register (for compatibility with FL IL 24 BK)
Special register	1280	–	–	Read/write	Modbus timeout connection monitoring
	2000	–	–	Read/write	Process data watchdog timeout
	2002	–	–	Read/write	Fault response mode
	2004	–	–	Read/write	NetFail test (same value as register 6)
	2006	–	–	Read/write	Command register

13.4 Modbus Function Codes

The following function codes are supported:

Code No.	Function Code
fc1	Read coils
fc2	Read input discretes
fc3	Read multiple registers
fc4	Read input registers
fc5	Write coils
fc6	Write single register
fc15	Write multiple coils
fc16	Write multiple registers
fc23	Read/write registers

13.6 Process Data Assignment (Modbus)

Assignment of the Terminal Points to the OUT Process Data Word (Slots 3 to 6)

(Word.bit) view	Word	Word 2															
	Bit	15	14	13	12	11	10	9	8	7	6	5	4	3	2	1	0
Module	Slot	6 (IO4)				5 (IO3)				4 (IO2)				3 (IO1)			
	Terminal point (signal)	2.4	1.4	2.1	1.1	2.4	1.4	2.1	1.1	2.4	1.4	2.1	1.1	2.4	1.4	2.1	1.1
	Terminal point (GND)	2.6	1.6	2.3	1.3	2.6	1.6	2.3	1.3	2.6	1.6	2.3	1.3	2.6	1.6	2.3	1.3
Status indicator	Slot	6 (IO4)				5 (IO3)				4 (IO2)				3 (IO1)			
	LED	4	3	2	1	4	3	2	1	4	3	2	1	4	3	2	1

Assignment of the Terminal Points to the IN Process Data Word (Slots 3 to 6)

(Word.bit) view	Word	Word 0															
	Bit	15	14	13	12	11	10	9	8	7	6	5	4	3	2	1	0
Module	Slot	6 (IO4)				5 (IO3)				4 (IO2)				3 (IO1)			
	Terminal point (signal)	2.4	1.4	2.1	1.1	2.4	1.4	2.1	1.1	2.4	1.4	2.1	1.1	2.4	1.4	2.1	1.1
	Terminal point (U ₁₁)	2.5	1.5	2.2	1.2	2.5	1.5	2.2	1.2	2.5	1.5	2.2	1.2	2.5	1.5	2.2	1.2
	Terminal point (GND)	2.6	1.6	2.3	1.3	2.6	1.6	2.3	1.3	2.6	1.6	2.3	1.3	2.6	1.6	2.3	1.3
Status indicator	Slot	6 (IO4)				5 (IO3)				4 (IO2)				3 (IO1)			
	LED	4	3	2	1	4	3	2	1	4	3	2	1	4	3	2	1

Assignment of the Terminal Points to the IN Process Data Word (Slots 7 to 10)

(Word.bit) view	Word	Word 1															
	Bit	15	14	13	12	11	10	9	8	7	6	5	4	3	2	1	0
Module	Slot	10 (I4)				9 (I3)				8 (I2)				7 (I1)			
	Terminal point (signal)	2.4	1.4	2.1	1.1	2.4	1.4	2.1	1.1	2.4	1.4	2.1	1.1	2.4	1.4	2.1	1.1
	Terminal point (U ₁₂)	2.5	1.5	2.2	1.2	2.5	1.5	2.2	1.2	2.5	1.5	2.2	1.2	2.5	1.5	2.2	1.2
	Terminal point (GND)	2.6	1.6	2.3	1.3	2.6	1.6	2.3	1.3	2.6	1.6	2.3	1.3	2.6	1.6	2.3	1.3
Status indicator	Slot	10 (I4)				9 (I3)				8 (I2)				7 (I1)			
	LED	4	3	2	1	4	3	2	1	4	3	2	1	4	3	2	1

14 Device Driver Interface (DDI)

The ILB ETH 24 DI16 DIO16-2TX module supports access via the Device Driver Interface (DDI).



A driver for Windows NT and Windows 2000 can be found at www.download.phoenixcontact.com. It is called "Ethernet Driver 2.0. exe". Phoenix Contact informs you about drivers for other operating systems on request.

Using this interface requires the appropriate driver to be installed on the host. For a detailed description of the services, please refer to the "Driver Reference Manual for G4-Based Controller Boards Using PC Bus and Ethernet", see "Ordering Data" on page 4.

The following services are supported: Services for remote access to the DDI

- DDI_DevOpenNode ()
- DDI_DevCloseNode ()
- DDI_DTI_ReadData ()
- DDI_DTI_WriteData ()
- DDI_DTI_ReadWriteData ()
- GetIBSDiagnostic ()



The module only supports the process data channel (DTI). Access to the mailbox channel (MXI) is not supported and thus rejected with the corresponding error message.

14.1 Connection and Error Monitoring

- ETH_SetDTITimeoutCtrl ()
- ETH_ClearDTITimeoutCtrl ()
- ETH_SetNet Fail ()
- ETH_GetNet FailStatus ()
- ETH_ClrNet FailStatus ()
- ETH_SetNet FailMode ()
- ETH_GetNet FailMode ()

14.2 Services for Process Data Monitoring

- ETH_ActivatePDinMonitoring ()
- ETH_DeactivatePDinMonitoring ()

14.3 Services for Ethernet Connection Management

- ETH_InitiateManagement ()
- ETH_AbortManagement ()
- ETH_HardwareReset ()
- ETH_EnableHardwareReset ()
- ETH_DisableHardwareReset ()

14.4 Structure of the DTI Area



The special registers can only be accessed individually with a length of 2 bytes. In this way invalid parameters can be rejected selectively.

	Byte Address		DTI IN	DTI OUT	Remark
	From	To	Read Access	Write Access	
Process data	00 _{hex}	01 _{hex}	16 bit IN (DIO)	16 bit OUT (DIO)	
	02 _{hex}	03 _{hex}	16 bit IN (DI)	Disabled	
	04 _{hex}	05 _{hex}	16 bit OUT (DIO)	Disabled	Read back output register
Diagnostics	08 _{hex}	09 _{hex}	Status register	Disabled	
	0A _{hex}	0B _{hex}	I/O diagnostic register	Disabled	
	0C _{hex}	0D _{hex}	NetFail reason	Disabled	
	0E _{hex}	0F _{hex}	IBS diagnostic register	Disabled	For OPC compatibility
	10 _{hex}	11 _{hex}	IBS para register	Disabled	For OPC compatibility
Special register	4000 _{dec}	4001 _{dec}	Process data watchdog timeout	Process data watchdog timeout	
	4004 _{dec}	4005 _{dec}	Fault response mode	Fault response mode	
	4008 _{dec}	4009 _{dec}	NetFail test	NetFail test	Same value as register 0C _{hex}
	4012 _{dec}	4013 _{dec}	Command register	Command register	

14.5 Process Data Assignment (DDI)

Assignment of the Terminal Points to the OUT Process Data Word (Slots 3 to 6)

(Byte.bit) view	Word	Byte 0								Byte 1							
	Bit	7	6	5	4	3	2	1	0	7	6	5	4	3	2	1	0
Module	Slot	6 (IO4)				5 (IO3)				4 (IO2)				3 (IO1)			
	Terminal point (signal)	2.4	1.4	2.1	1.1	2.4	1.4	2.1	1.1	2.4	1.4	2.1	1.1	2.4	1.4	2.1	1.1
	Terminal point (GND)	2.6	1.6	2.3	1.3	2.6	1.6	2.3	1.3	2.6	1.6	2.3	1.3	2.6	1.6	2.3	1.3
Status indicator	Slot	6 (IO4)				5 (IO3)				4 (IO2)				3 (IO1)			
	LED	4	3	2	1	4	3	2	1	4	3	2	1	4	3	2	1

Assignment of the Terminal Points to the IN Process Data Word (Slots 3 to 6)

(Byte.bit) view	Word	Byte 0								Byte 1							
	Bit	7	6	5	4	3	2	1	0	7	6	5	4	3	2	1	0
Module	Slot	6 (IO4)				5 (IO3)				4 (IO2)				3 (IO1)			
	Terminal point (signal)	2.4	1.4	2.1	1.1	2.4	1.4	2.1	1.1	2.4	1.4	2.1	1.1	2.4	1.4	2.1	1.1
	Terminal point (U _{I1})	2.5	1.5	2.2	1.2	2.5	1.5	2.2	1.2	2.5	1.5	2.2	1.2	2.5	1.5	2.2	1.2
	Terminal point (GND)	2.6	1.6	2.3	1.3	2.6	1.6	2.3	1.3	2.6	1.6	2.3	1.3	2.6	1.6	2.3	1.3
Status indicator	Slot	6 (IO4)				5 (IO3)				4 (IO2)				3 (IO1)			
	LED	4	3	2	1	4	3	2	1	4	3	2	1	4	3	2	1

Assignment of the Terminal Points to the IN Process Data Word (Slots 7 to 10)

(Byte.bit) view	Word	Byte 2								Byte 3							
	Bit	7	6	5	4	3	2	1	0	7	6	5	4	3	2	1	0
Module	Slot	10 (I4)				9 (I3)				8 (I2)				7 (I1)			
	Terminal point (signal)	2.4	1.4	2.1	1.1	2.4	1.4	2.1	1.1	2.4	1.4	2.1	1.1	2.4	1.4	2.1	1.1
	Terminal point (U _{I2})	2.5	1.5	2.2	1.2	2.5	1.5	2.2	1.2	2.5	1.5	2.2	1.2	2.5	1.5	2.2	1.2
	Terminal point (GND)	2.6	1.6	2.3	1.3	2.6	1.6	2.3	1.3	2.6	1.6	2.3	1.3	2.6	1.6	2.3	1.3
Status indicator	Slot	10 (I4)				9 (I3)				8 (I2)				7 (I1)			
	LED	4	3	2	1	4	3	2	1	4	3	2	1	4	3	2	1

15 Diagnostic Register

15.1 Status Register

Address:

- Modbus: Register 4
- DDI: Word starting with 08_{hex}

Via the Ethernet host controller, e.g., PLC, the user can read current diagnostic information from the network interface status word without using a configuration software.

Only those two least significant bits (bit 0 and bit 1) have a function. Bit 2 up to bit 15 are reserved.

- Bit 0 = 0: An error occurred (e.g., a bit in the diagnostic register is set).
- Bit 0 = 1: No error
- Bit 1 = 0: No NetFail
- Bit 1 = 1: NetFail is present

This results in the following values for the status word:

Register Contents	Status
0000 _{hex}	An error occurred (e.g., a bit in the diagnostic register is set).
0001 _{hex}	No error occurred.
0002 _{hex}	A NetFail occurred.



The errors are indicated until they are acknowledged.

15.2 I/O Diagnostic Register

Address:

- Modbus: Register 5
- DDI: Word starting with 04_{hex}

The I/O diagnostic register is used to indicate detailed information on module diagnostics. The DIA LED is red if a bit is set here.

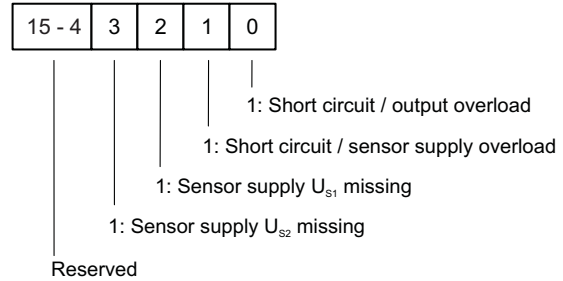

704601008

Figure 15 Assignment of the I/O diagnostic register



The diagnostic register always indicates the current status.

15.3 NetFail Reason

Address:

- Modbus: Register 6
- DDI: Word starting with 0C_{hex}

This register can be used to read the NetFail reason after setting the NetFail signal. If no NetFail signal is present the register is 0. For a list of the reasons, please refer to Section "Reasons for Fault Response" on page 24.

16 Special Register

16.1 Modbus Connection Timeout

Modbus: Register 1280

A monitoring mechanism can be activated for every Modbus/TCP connection in order for the ILB ETH 24 DI16 DIO16-2TX module to detect an error in the network (e.g., defective cable) or in the client (operating system crash or error in the TCP/IP protocol stack) and react accordingly. The monitoring mechanism is activated via the relevant TCP connection upon the first read or write procedure.

To change the timeout value for the relevant TCP connection, write the new timeout value to the timeout table to the special address 1280 using functions "fc 6" or "fc 16". The value of this entry is the value of the timeout table. The time is specified in milliseconds in the range from 200 ms to 65000 ms.

A timeout value of "0" deactivates the monitoring function. Values between 1 ms and 199 ms, and values greater than 65000 ms generate exception response 3 (ILLEGAL DATA VALUE).



Connection monitoring with the new timeout values is only activated after a Modbus/TCP function has been executed on the relevant TCP connection.

After the first access by a Modbus/TCP function, all other access must be carried out using the entered timeout value. Otherwise, fault response mode is activated and the Modbus/TCP connection is disabled.

16.2 Process Data Watchdog Timeout

- Modbus: Register 2000
- DDI: Word starting with 4000_{dec}

Setting or reading the timeout value for the process data watchdog. The time is specified in milliseconds in the range from 200 ms to 65000 ms. A timeout value of "0" deactivates the watchdog, see also page 23.

16.3 Fault Response Mode

- Modbus: Register 2002
- DDI: Value starting with 4004_{dec}

Setting or reading the fault response mode. For information on fault response mode settings, please refer to Section "Setting the Required Fault Response Mode" on page 22.

16.4 Command Register

- Modbus: Register 2006
- DDI: Value starting with 4012_{dec}

The network interface command register can be used to transmit commands with basic functions to the module using the Ethernet host controller, e.g., PLC.

Command	Function Code
0000 _{hex}	No action
0002 _{hex}	NetFail acknowledgement
0004 _{hex}	Diagnostic message acknowledgement (I/O error)

© PHOENIX CONTACT 03/2007



**SCATTERGOOD
& JOHNSON LTD**
ELECTRICAL ENGINEERING & FLUID CONTROL DISTRIBUTORS

Est.1899

At Scattergood & Johnson Ltd, we pride ourselves on being a technical distributor to specialist industries.

Working with a range of quality product suppliers across a number of specialist markets, we are not your average 'box shifter' - we are your technical and supply chain partner.

We fully support every product we sell - for free! Our internal team and external sales engineers can answer any product or application question, no matter the complexity.

Backing up this technical ability is a range of 50,000+ products available from stock for nationwide next day delivery (same day if required!), or you can collect what you need from any of our trade counters around the UK.

Select your specialist interest below to learn more about how we can help.

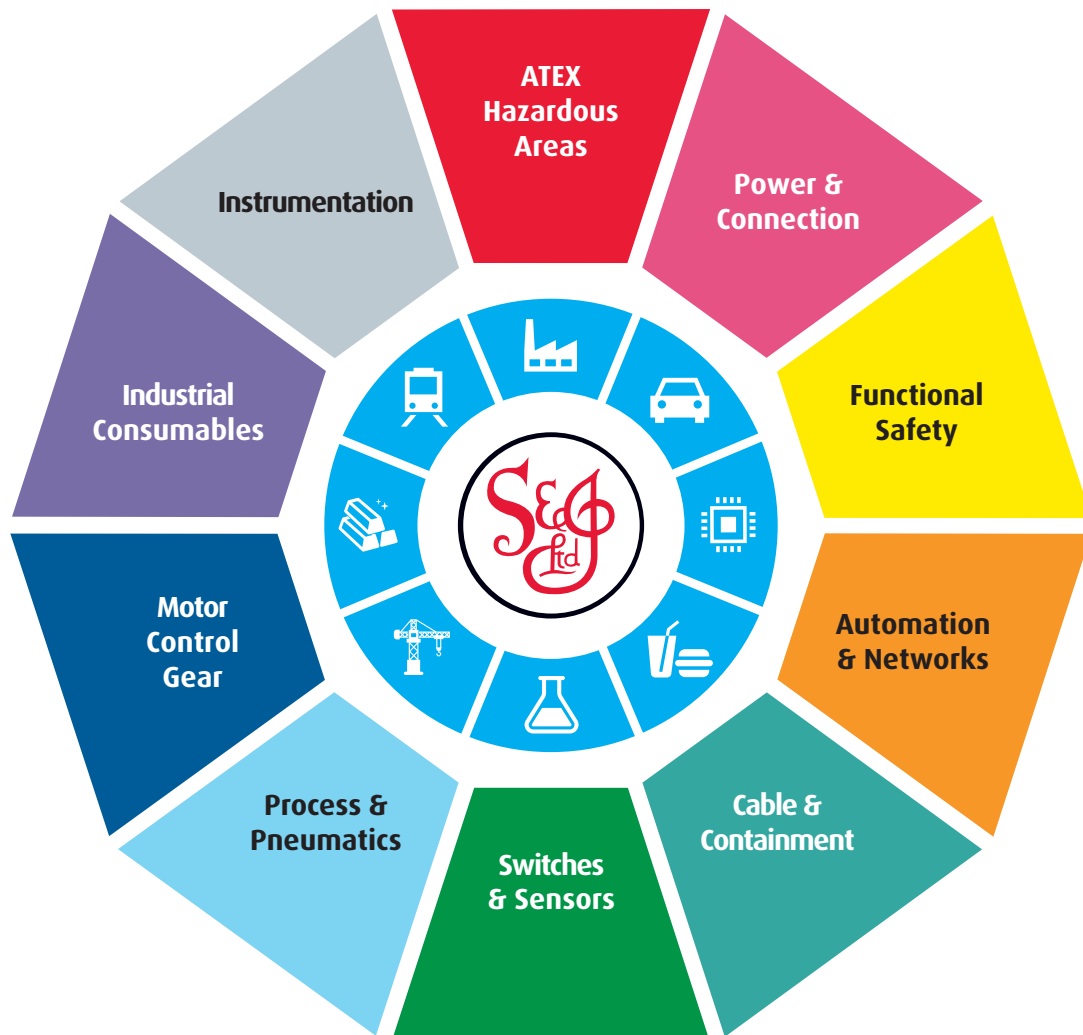

Online, In Branch and On the Road - Scattergood & Johnson Ltd, there when you need us.

www.scatts.co.uk