

# IB IL 24 DI 4(-2MBD)-PAC

**Inline, digital input terminal,  
digital inputs: 4, 24 V DC**

Data sheet  
5550\_en\_07

© PHOENIX CONTACT 2017-10-04

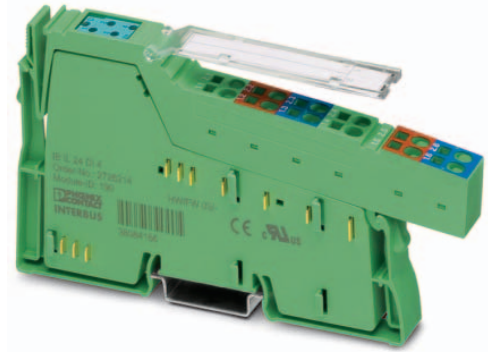

## 1 Description

The terminal is designed for use within an Inline station.  
It is used to acquire digital signals.

### Features

- 4 digital inputs
- Connection of sensors in 2 and 3-wire technology
- Maximum permissible load current per sensor: 250 mA
- Maximum permissible load current from the terminal:  
1 A



#### IB IL 24 DI 4-PAC

**WARNING: Explosion hazard when used in potentially explosive areas**

When using the terminal in potentially explosive areas, observe the corresponding notes.



This data sheet is only valid in association with the IL SYS INST UM E user manual.



Make sure you always use the latest documentation.

It can be downloaded from the product at [phoenixcontact.net/products](http://phoenixcontact.net/products).

---

<b>2</b>	<b>Table of contents</b>	
1	Description .....	1
2	Table of contents .....	2
3	Ordering data .....	3
4	Technical data .....	4
5	Additional tables .....	7
	5.1 Input characteristic curve .....	7
	5.2 Power dissipation .....	7
	5.3 Limitation of simultaneity, derating .....	8
6	Internal circuit diagram .....	8
7	Notes on using the terminal block in potentially explosive areas .....	9
8	Terminal point assignment.....	10
9	Connection notes and examples .....	10
10	Local diagnostic and status indicators .....	11
11	Process data.....	11

### 3 Ordering data

Description	Type	Order No.	Pcs./Pkt.
Inline, Digital input terminal, Digital inputs: 4, 24 V DC, connection method: 3-conductor, transmission speed in the local bus 500 kbps, degree of protection IP20, including Inline connector and labeling field	IB IL 24 DI 4-PAC	2861234	1
Inline, Digital input terminal, Digital inputs: 4, 24 V DC, connection method: 3-conductor, transmission speed in the local bus 2 Mbps, degree of protection IP20, including Inline connector and labeling field	IB IL 24 DI 4-2MBD-PAC	2692306	1
Accessories	Type	Order No.	Pcs./Pkt.
Inline connector, colored (Connector/Adapter)	IB IL SCN-8-CP	2727608	10
Connector, for digital 1, 2 or 8-channel Inline terminals (Connector/Adapter)	IB IL SCN-8	2726337	10
Labeling field, width: 12.2 mm (Marking)	IB IL FIELD 2	2727501	10
Insert strip, Sheet, white, unlabeled, can be labeled with: Office printing systems: Laser printer, mounting type: insert, lettering field size: 62 x 10 mm (Marking)	ESL 62X10	0809492	1
Documentation	Type	Order No.	Pcs./Pkt.
User manual, English, Automation terminals of the Inline product range	IL SYS INST UM E	-	-
Data sheet, English, INTERBUS addressing	DB GB IBS SYS ADDRESS	-	-
Application note, English, Inline terminals for use in zone 2 potentially explosive areas	AH EN IL EX ZONE 2	-	-

## 4 Technical data

### Dimensions (nominal sizes in mm)

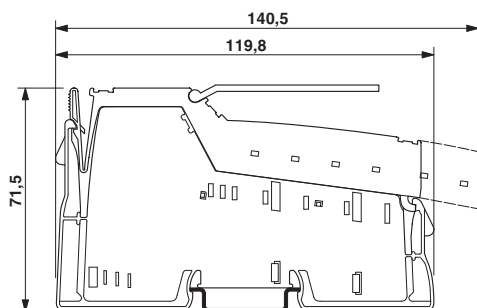

Width	12.2 mm
Height	140.5 mm
Depth	71.5 mm
Note on dimensions	Housing dimensions

### General data

Color	green
Weight	66 g (with connector)
Operating mode	Process data operation with 4 bits
Ambient temperature (operation)	-25 °C ... 55 °C
Ambient temperature (storage/transport)	-25 °C ... 85 °C
Permissible humidity (operation)	10 % ... 95 % (non-condensing)
Permissible humidity (storage/transport)	10 % ... 95 % (non-condensing)
Air pressure (operation)	70 kPa ... 106 kPa (up to 3000 m above sea level) 80 kPa ... 106 kPa (up to 3000 m above sea level, in ATEX Zone 2)
Air pressure (storage/transport)	70 kPa ... 106 kPa (up to 3000 m above sea level)
Degree of protection	IP20
Protection class	III, IEC 61140, EN 61140, VDE 0140-1

### Connection data

Designation	Inline connector
Connection method	Spring-cage connection
Conductor cross section solid / stranded	0.08 mm <sup>2</sup> ... 1.5 mm <sup>2</sup> / 0.08 mm <sup>2</sup> ... 1.5 mm <sup>2</sup>
Conductor cross section [AWG]	28 ... 16
Stripping length	8 mm

**Connection data for UL approvals**

Designation	Inline connector
Connection method	Spring-cage connection
Conductor cross section solid / stranded	0.2 mm <sup>2</sup> ... 1.5 mm <sup>2</sup> / 0.2 mm <sup>2</sup> ... 1.5 mm <sup>2</sup>
Conductor cross section [AWG]	24 ... 16
Stripping length	8 mm

**Interface Inline local bus**

Number	2
Connection method	Inline data jumper

**Transmission speed Inline local bus**

IB IL 24 DI 4-PAC	500 kbps
IB IL 24 DI 4-2MBD-PAC	2 Mbps

**Communications power U<sub>L</sub> (500 kbps)**

Supply voltage	7.5 V DC (via voltage jumper)
Current draw	max. 40 mA
Power consumption	max. 0.3 W

**Communications power U<sub>L</sub> (2 Mbps)**

Supply voltage	7.5 V DC (via voltage jumper)
Current draw	max. 51 mA
Power consumption	max. 0.4 W

**Segment circuit supply U<sub>S</sub>**

Supply voltage	24 V DC (via voltage jumper)
Supply voltage range	19.2 V DC ... 30 V DC (including all tolerances, including ripple)
Current draw	max. 1 A

**WARNING – Explosion hazard when used in ATEX Zone 2**

Make sure that the maximum permissible current of 4 A flowing through potential jumpers U<sub>M</sub> and U<sub>S</sub> (total current) is not exceeded.

**Digital inputs**

Number of inputs	4
Connection method	Spring-cage connection
Connection technology	3-conductor
Description of the input	EN 61131-2 type 1
Nominal input voltage	24 V DC
Nominal input current	min. 3 mA (at nominal voltage)
Input voltage range "0" signal	-3 V DC ... 5 V DC
Input voltage range "1" signal	15 V DC ... 30 V DC
Permissible conductor length to the sensor	30 m
Use of AC sensors	AC sensors in the voltage range < U <sub>IN</sub> are limited in application (according to the input design)
Short-circuit and overload protection	yes

**Programming data (INTERBUS, local bus)**

ID code (hex)	BE
ID code (dec.)	190
Length code (hex)	41
Length code (dec.)	65
Process data channel	4 Bit
Input address area	4 Bit
Output address area	0 Bit
Parameter channel (PCP)	0 Bit
Register length (bus)	4 Bit



For the programming data/configuration data of other bus systems, please refer to the corresponding electronic device data sheet (e.g., GSD, EDS).

**Configuration and parameter data in a PROFIBUS system**

Required parameter data	1 Byte
Need for configuration data	4 Byte

**Error messages to the higher level control or computer system**

None

**Electrical isolation/isolation of the voltage areas**

Test section	Test voltage
7.5 V supply (bus logics)/24 V supply (I/O)	500 V AC, 50 Hz, 1 min.
24 V supply (I/O) / functional earth ground	500 V AC, 50 Hz, 1 min.
7.5 V supply (bus logics) / functional earth ground	500 V AC, 50 Hz, 500 min.



To achieve electrical isolation between the logic level and the I/O area, supply these areas from separate power supply units. Interconnection of the power supply units in the 24 V area is not permitted (see IL SYS INST UM E user manual).

**Approvals**

For the latest approvals, please visit [phoenixcontact.net/products](http://phoenixcontact.net/products).

## 5 Additional tables

### 5.1 Input characteristic curve

500 kbps

Current depending on the input voltage and the ambient temperature  $T_A$

Supply voltage [V]	Input current [mA]	Input current for $t \geq 20$ s [mA]	
		$T_A = 25^\circ\text{C}$	$T_A = 55^\circ\text{C}$
18	3.0	2.9	2.5
24	3.9	3.8	3.5
30	4.5	4.2	3.0

The current is reduced depending on the ambient temperature and the number of inputs that are switched on (internal module temperature).

### 5.2 Power dissipation

Formula for calculating the power dissipation of the electronics

$$P_{EL} = 0,24 \text{ W} + \sum_{i=1}^n (U_{INI} \times 0,003 \text{ A})$$

Where:

$P_{EL}$  Total power dissipation in the terminal

$i$  Continuous index

$n$  Number of set inputs ( $n = 1 \dots 4$ )

$U_{INI}$  Input voltage of input  $i$

#### Power dissipation of the housing

Maximum 0.6 W (within the permissible operating temperature)

5.3 Limitation of simultaneity, derating

500 kbps

No limitation of simultaneity, no derating

2 Mbps

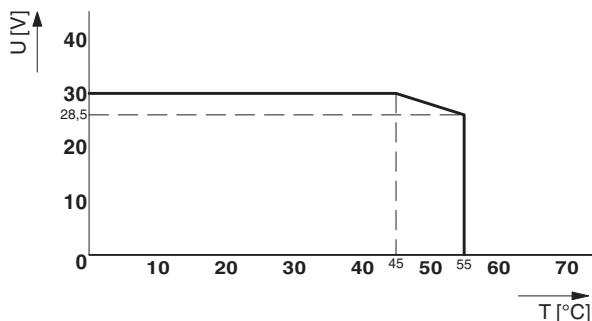

Figure 1 Derating diagram



An example for calculating the working point can be found in the user manual IL SYS INST UM E.

6 Internal circuit diagram

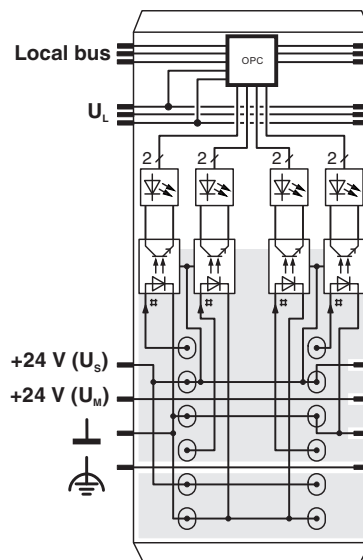

Figure 2 Internal wiring of the terminal points

Key:



Protocol chip  
(Bus logic including voltage conditioning)



LED (status indicator)



Optocoupler



Digital input



Electrically isolated area



Explanation for other used symbols has been provided in the IL SYS INST UM E user manual.

## 7 Notes on using the terminal block in potentially explosive areas

Valid for: **IB IL 24 DI 4-PAC**



**WARNING: Explosion hazard**

Please make sure that the following notes and instructions are observed.

### Approval according to ATEX Directive 2014/34/EU

⊕ II 3 G Ex nA IIC T4 Gc X

### Installation notes

$T_{amb} = -25\text{ °C} \dots +55\text{ °C}$

The category 3 device is designed for installation in zone 2 potentially explosive areas.

The device meets the requirements of EN 60079–0:2012 + A11:2013 and EN 60079–15:2010.

- Observe the specified conditions for use in potentially explosive areas! Also observe the requirements of EN 60079-14.
- Install the device in a suitable approved housing (with at least IP54 protection) that meets the requirements of EN 60079-15.
- Only assemble, disassemble as well as connect and disconnect cables when the power is disconnected.
- Only devices that are designed for operation in Ex Zone 2 and the conditions at the installation location may be connected to the circuits in Zone 2.
- For safe operation, lockable plug connections must have a functional interlock (e. g. locking clip, screw connection etc.). Insert the interlock. Repair any damaged connectors immediately.
- Only connect one cable per terminal point.
- Use transient protection so that short-term surge voltages do not exceed 119 V.
- The air pressure during operation must not exceed 106 kPa.
- Perform a dielectric test after installing the device in the housing.
- For all supply and signal lines connected to the station, make sure that there is a connection to ground potential.
- Make sure that the maximum permissible current of 4 A flowing through potential jumpers  $U_M$  and  $U_S$  (total current) is not exceeded.
- When using the device in potentially explosive areas, observe the specifications in the application note AH DE IL EX ZONE 2 (German) / AH EN IL EX ZONE 2 (English).

## 8 Terminal point assignment

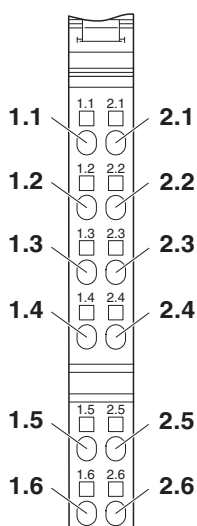

Figure 3 Terminal point assignment

Terminal point	Assignment
1.1 / 2.1	Signal input (IN01 / IN02)
1.2 / 2.2	Segment voltage $U_S$ for 2 and 3-wire connection
1.3 / 2.3	Ground contact (GND) for 3-wire connection
1.4 / 2.4	Signal input (IN03 / IN04)
1.5 / 2.5	Segment voltage $U_S$ for 2 and 3-wire connection
1.6 / 2.6	Ground contact (GND) for 3-wire connection

## 9 Connection notes and examples



**NOTE: Malfunction**

The supply voltage  $U_S$  is used internally as the auxiliary supply. If it is not present, the terminal will not operate properly. Make sure that the supply voltage  $U_S$  is available.



When connecting the sensors observe the assignment of the terminal points to the process data.

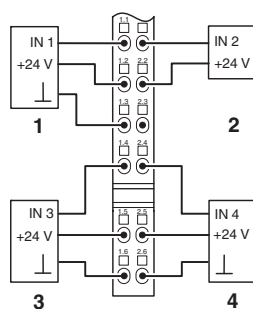

Figure 4 Typical connection of sensors

- 1, 3, 4 3-wire connection
- 2 2-wire connection

## 10 Local diagnostic and status indicators

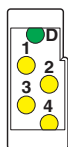

Figure 5 Local diagnostic and status indicators

Designation	Color	Meaning
D	Green	Diagnostics (bus and logic voltage)
1 ... 4	Yellow	Status of the inputs

### Function identification

Light blue

2 Mbps: White stripe in the vicinity of the D LED

## 11 Process data

### Assignment of the terminal points to the output process data

(Byte.Bit) view	Byte.Bit	0.3	0.2	0.1	0.0
Assignment	Signal	IN04	IN03	IN02	IN01
	Terminal point (signal)	2.4	1.4	2.1	1.1
	Terminal point (24 V)	2.5	1.5	2.2	1.2
	Terminal point (GND)	2.6	1.6	2.3	1.3
Status indicator	LED	4	3	2	1



For the assignment of the illustrated (byte.bit) view to your INTERBUS control or computer system, please refer to the DB GB IBS SYS ADDRESS data sheet.



# SCATTERGOOD & JOHNSON LTD

ELECTRICAL ENGINEERING & FLUID CONTROL DISTRIBUTORS

Est.1899

At Scattergood & Johnson Ltd, we pride ourselves on being a technical distributor to specialist industries.

Working with a range of quality product suppliers across a number of specialist markets, we are not your average 'box shifter' - we are your technical and supply chain partner.

We fully support every product we sell - for free! Our internal team and external sales engineers can answer any product or application question, no matter the complexity.

Backing up this technical ability is a range of 50,000+ products available from stock for nationwide next day delivery (same day if required!), or you can collect what you need from any of our trade counters around the UK.

Select your specialist interest below to learn more about how we can help.



Online, In Branch and On the Road - Scattergood & Johnson Ltd, there when you need us.

# [www.scatts.co.uk](http://www.scatts.co.uk)