

IB IL 24 DO 4(-2MBD)-PAC

**Inline, digital output terminal,
digital outputs: 4, 24 V DC, 500 mA**

Data sheet
5557_en_06

© PHOENIX CONTACT 2018-04-03

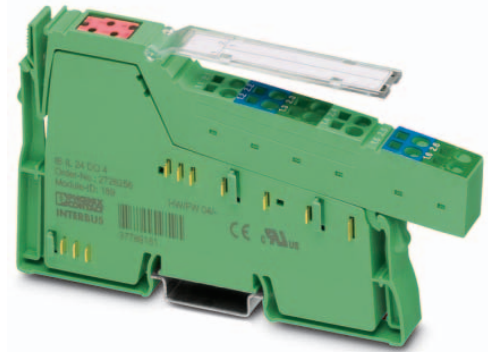

1 Description

The terminal is designed for use within an Inline station. It is used to output digital signals.

Features

- 4 digital outputs
- Connection of actuators in 2 and 3-wire technology
- Nominal current per output: 500 mA
- Total current of the terminal: 2 A
- Short-circuit-proof and overload-protected outputs



IB IL 24 DO 4-PAC

WARNING: Explosion hazard when used in potentially explosive areas

When using the terminal in potentially explosive areas, observe the corresponding notes.



This data sheet is only valid in association with the IL SYS INST UM E user manual.



Make sure you always use the latest documentation.

It can be downloaded from the product at phoenixcontact.net/products.

2	Table of contents	
1	Description	1
2	Table of contents	2
3	Ordering data	3
4	Technical data	4
5	Additional tables	8
5.1	Output characteristic curve.....	8
5.2	Power dissipation	8
5.3	Limitation of simultaneity, derating	8
6	Internal circuit diagram	9
7	Notes on using the terminal block in potentially explosive areas	10
8	Terminal point assignment.....	11
9	Connection notes and examples	11
10	Local diagnostic and status indicators	12
11	Process data.....	12

3 Ordering data

Description	Type	Order No.	Pcs./Pkt.
Inline, digital output terminal, digital outputs: 4, 24 V DC, 500 mA, connection method: 3-wire, transmission speed in the local bus: 500 kbps, degree of protection: IP20, including Inline connector and labeling field	IB IL 24 DO 4-PAC	2861276	1
Inline, digital output terminal, digital outputs: 4, 24 V DC, 500 mA, connection method: 3-wire, transmission speed in the local bus: 2 Mbps, degree of protection: IP20, including Inline connector and labeling field	IB IL 24 DO 4-2MBD-PAC	2861988	1
Accessories	Type	Order No.	Pcs./Pkt.
Connector, colored identification, for digital 4, or 16-channel Inline output terminal blocks (Connector/Adapter)	IB IL SCN-12-OCP	2727624	10
Connector, for digital 4 or 16-channel Inline terminals (Connector/Adapter)	IB IL SCN-12	2726340	10
Labeling field, width: 12.2 mm (Marking)	IB IL FIELD 2	2727501	10
Insert strip, Sheet, white, unlabeled, can be labeled with: Office printing systems: Laser printer, mounting type: insert, lettering field size: 62 x 10 mm (Marking)	ESL 62X10	0809492	1
Documentation	Type	Order No.	Pcs./Pkt.
User manual, English, Automation terminals of the Inline product range	IL SYS INST UM E	-	-
Data sheet, English, INTERBUS addressing	DB GB IBS SYS ADDRESS	-	-
Application note, English, Inline terminals for use in zone 2 potentially explosive areas	AH EN IL EX ZONE 2	-	-

4 Technical data

Dimensions (nominal sizes in mm)

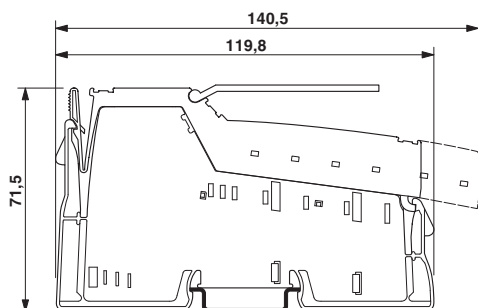

Width	12.2 mm
Height	140.5 mm
Depth	71.5 mm
Note on dimensions	Housing dimensions

General data

Color	green
Weight	66 g (with connector)
Operating mode	Process data operation with 4 bits
Ambient temperature (operation)	-25 °C ... 55 °C
Ambient temperature (storage/transport)	-25 °C ... 85 °C
Permissible humidity (operation)	10 % ... 95 % (non-condensing)
Permissible humidity (storage/transport)	10 % ... 95 % (non-condensing)
Air pressure (operation)	70 kPa ... 106 kPa (up to 3000 m above sea level) 80 kPa ... 106 kPa (up to 3000 m above sea level, in ATEX Zone 2)
Air pressure (storage/transport)	70 kPa ... 106 kPa (up to 3000 m above sea level)
Degree of protection	IP20
Protection class	III, IEC 61140, EN 61140, VDE 0140-1

Connection data: Inline connector

Connection method	Spring-cage connection
Conductor cross section solid / stranded	0.08 mm ² ... 1.5 mm ² / 0.08 mm ² ... 1.5 mm ²
Conductor cross section [AWG]	28 ... 16
Stripping length	8 mm

Connection data for UL approvals: Inline connector

Connection method	Spring-cage connection
Conductor cross section solid / stranded	0.2 mm ² ... 1.5 mm ² / 0.2 mm ² ... 1.5 mm ²
Conductor cross section [AWG]	24 ... 16
Stripping length	8 mm

Interface: Inline local bus

Number	2
Connection method	Inline data jumper

Transmission speed Inline local bus

IB IL 24 DO 4-PAC	500 kbps
IB IL 24 DO 4-2MBD-PAC	2 Mbps

Communications power U_L (500 kbps)

Supply voltage	7.5 V DC (via voltage jumper)
Current draw	max. 44 mA
Power consumption	max. 0.33 W

Communications power U_L (2 Mbps)

Supply voltage	7.5 V DC (via voltage jumper)
Current draw	max. 65 mA
Power consumption	max. 0.49 W

Segment circuit supply U_S

Supply voltage	24 V DC (via voltage jumper)
Supply voltage range	19.2 V DC ... 30 V DC (including all tolerances, including ripple)
Current draw	max. 2 A

**WARNING – Explosion hazard when used in ATEX Zone 2**

Make sure that the maximum permissible current of 4 A flowing through potential jumpers U_M and U_S (total current) is not exceeded.

Protective circuit

Overload protection, short-circuit protection in the segment circuit	electronic
--	------------

Digital outputs

Number of outputs	4
Connection method	Spring-cage connection
Connection technology	3-wire
Nominal output voltage	24 V DC
Voltage difference with nominal current	≤ 1 V
Maximum output current per channel	500 mA
Maximum output current per device	2 A
Nominal load, ohmic	12 W (48 Ω)
Nominal load, inductive	12 VA (1.2 H, 50 Ω)
Nominal load, lamp	12 W
Signal delay when switching on an ohmic nominal load	typ. 100 μ s
Signal delay when switching on an inductive nominal load	typ. 100 ms (1.2 H, 50 Ω)
Signal delay when switching on a lamp nominal load	typ. 100 ms (for switching frequencies up to 8 Hz, above this frequency, the lamp load behaves like an ohmic load)

Digital outputs	
Signal delay when switching off an ohmic nominal load	typ. 1 ms
Signal delay when switching off an inductive nominal load	typ. 50 ms (1.2 H, 50 Ω)
Signal delay when switching off a lamp nominal load	typ. 1 ms
Maximum operating frequency with ohmic nominal load	max. 300 Hz (this switching frequency is limited by the data rate selected, the number of bus devices, the structure of the bus, the software used and the control or computer system used)
Maximum operating frequency with inductive nominal load	max. 0.5 Hz (1.2 H, 50 Ω)
Maximum operating frequency with lamp nominal load	max. 300 Hz (this switching frequency is limited by the data rate selected, the number of bus devices, the structure of the bus, the software used and the control or computer system used)
Reaction time with short-circuit	ca. 850 ms
Reaction time with ohmic overload	ca. 3 s
Behavior at voltage switch-off	The output follows the power supply without delay
Output data validity	typ. 5 ms (after switching the 24 V voltage supply (power up))
One-time unsolicited energy	400 mJ
Limitation of the voltage induced on circuit interruption	-46 V ... -15 V
Output voltage when switched off	max. 2 V
Output current when switched off	max. 300 μ A
Behavior with overload	Auto restart
Behavior with inductive overload	Output can be destroyed
Restart frequency with ohmic overload	250 Hz
Restart frequency with lamp overload	250 Hz
Reverse voltage resistance to short pulses	Reverse voltage proof
Resistance to permanent reverse voltage	to 2 A DC
Resistance to permanently applied surge voltage	no
Overcurrent shut-down	min. 0.7 A
Output current with ground connection interrupt when switched off	max. 25 mA
Switching capacity with ground connection interrupt	typ. 100 mW (at 1 k Ω load resistance)
Inrush current	max. 1.5 A (for 20 ms)
Overload protection, short-circuit protection of outputs	Zener diode in output chip
Note on protection circuit	The four channels are thermally coupled, i.e. an error in one channel can also influence the other channels.

Programming data (INTERBUS, local bus)

ID code (hex)	BD
ID code (dec.)	189
Length code (hex)	41
Length code (dec.)	65
Process data channel	4 Bit
Input address area	0 Bit
Output address area	4 Bit
Parameter channel (PCP)	0 Bit
Register length (bus)	4 Bit



For the programming data/configuration data of other bus systems, please refer to the corresponding electronic device data sheet (e.g., GSD, EDS).

Configuration and parameter data in a PROFIBUS system

Required parameter data	3 Byte
Required configuration data	4 Byte

Error messages to the higher level control or computer system

Short-circuit / overload of the digital outputs	Error message in the diagnostic code (bus) and display (2 Hz) via the LED (D) on the module
---	---

Electrical isolation/isolation of the voltage areas

Test section	Test voltage
7.5 V supply (bus logics)/24 V supply (I/O)	500 V AC, 50 Hz, 1 min.
24 V supply (I/O) / functional earth ground	500 V AC, 50 Hz, 1 min.
7.5 V supply (bus logics) / functional earth ground	500 V AC, 50 Hz, 1 min.



To achieve electrical isolation between the logic level and the I/O area, supply these areas from separate power supply units. Interconnection of the power supply units in the 24 V area is not permitted (see IL SYS INST UM E user manual).

Approvals

For the latest approvals, please visit phoenixcontact.net/products.

5 Additional tables

5.1 Output characteristic curve

Output characteristic curve when switched on (typical)	
Output current (A)	Differential output voltage (V)
0	0
0.1	0.04
0.2	0.08
0.3	0.12
0.4	0,16
0.5	0,20

5.2 Power dissipation

Formula for calculating the power dissipation of the electronics

500 kbps

$$P_{EL} = 0,19 \text{ W} + \sum_{i=1}^n (0,10 \text{ W} + I_{Li}^2 \times 0,40 \Omega)$$

2 Mbps

$$P_{EL} = 0,40 \text{ W} + \sum_{i=1}^n (0,10 \text{ W} + I_{Li}^2 \times 0,40 \Omega)$$

Where:

- P_{EL} Total power dissipation in the terminal
- i Continuous index
- n Number of outputs set ($n = 1 \dots 4$)
- I_{Li} Load current of output i

Power dissipation of the housing

Maximum 0.6 W (within the permissible operating temperature)

5.3 Limitation of simultaneity, derating

Ambient temperature T_{amb}	Maximum load current		
	100 % simultaneity	75 % simultaneity	50 % simultaneity
$\leq 35 \text{ }^\circ\text{C}$	0.5 A	0.5 A	0.5 A
$\leq 45 \text{ }^\circ\text{C}$	0.375 A	0.5 A	0.5 A
$\leq 55 \text{ }^\circ\text{C}$	0.25 A	0.33 A	0.5 A

At 100 % simultaneity, a load current of 0.5 A per channel is permissible within the ambient temperature range up to 35 °C, a load current of 0.375 A in the range from 35 °C to 45 °C and a load current of 0.25 A in the range from 45 °C to 55 °C.

If a maximum of two channels are operated in the overall permissible ambient temperature range (50% simultaneity), a load current of 0.5 A may be tapped.

If all channels are used, the permissible working point must be defined according to the above-stated formula.



An example for calculating the working point can be found in the user manual IL SYS INST UM E.

6 Internal circuit diagram

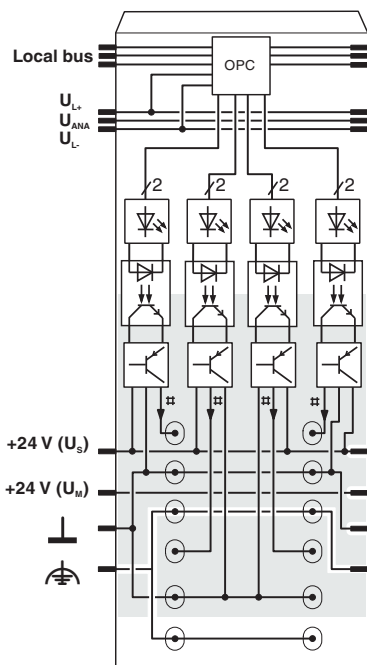









Figure 1 Internal wiring of the terminal points

Key:

-  Protocol chip
(Bus logic including voltage conditioning)
-  LED (status indicator)
-  Optocoupler
-  Transistor
-  Digital output
-  Electrically isolated area

 Please refer to the IL SYS INST UM E user manual for an explanation of other symbols used.

7 Notes on using the terminal block in potentially explosive areas

Valid for: **IB IL 24 DO 4-PAC**



WARNING: Explosion hazard

Please make sure that the following notes and instructions are observed.

Approval according to ATEX Directive 2014/34/EU

⊕ II 3 G Ex nA IIC T4 Gc X

Installation notes

$T_{amb} = -25\text{ °C} \dots +55\text{ °C}$

The category 3 device is designed for installation in zone 2 potentially explosive areas.

The device meets the requirements of EN 60079-0:2012 + A11:2013 and EN 60079-15:2010.

- Observe the specified conditions for use in potentially explosive areas! Also observe the requirements of EN 60079-14.
- Install the device in a suitable approved housing (with at least IP54 protection) that meets the requirements of EN 60079-15.
- Only assemble, disassemble as well as connect and disconnect cables when the power is disconnected.
- Only devices that are designed for operation in Ex Zone 2 and the conditions at the installation location may be connected to the circuits in Zone 2.
- For safe operation, lockable plug connections must have a functional interlock (e. g. locking clip, screw connection etc.). Insert the interlock. Repair any damaged connectors immediately.
- Only connect one cable per terminal point.
- Use transient protection so that short-term surge voltages do not exceed 119 V.
- The air pressure during operation must not exceed 106 kPa.
- Perform a dielectric test after installing the device in the housing.
- For all supply and signal lines connected to the station, make sure that there is a connection to ground potential.
- Make sure that the maximum permissible current of 4 A flowing through potential jumpers U_M and U_S (total current) is not exceeded.
- When using the device in potentially explosive areas, observe the specifications in the application note AH DE IL EX ZONE 2 (German) / AH EN IL EX ZONE 2 (English).

8 Terminal point assignment

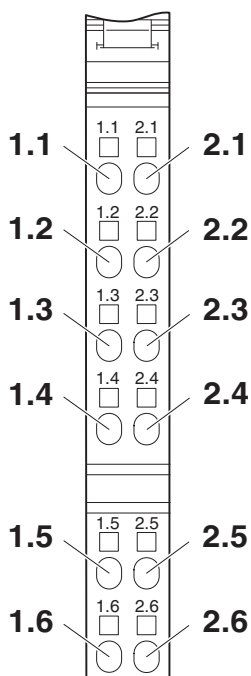

Figure 2 Terminal point assignment

Terminal point	Assignment
1.1 / 2.1	Signal output (OUT01 / OUT02)
1.2, 2.2	Ground contact (GND) for 2 and 3-wire connection
1.3, 2.3	FE connection for 3-wire connection
1.4 / 2.4	Signal output (OUT03 / OUT04)
1.5, 2.5	Ground contact (GND) for 2 and 3-wire connection
1.6, 2.6	FE connection for 3-wire connection

9 Connection notes and examples



When connecting the actuators, observe the assignment of the terminal points to the process data.

The connection of actuators in 2 and 3-wire technology is illustrated.

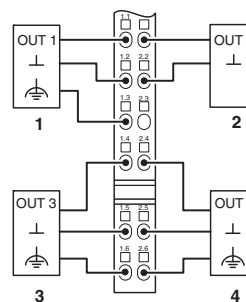

Figure 3 Typical connection of actuators

- 1, 3, 4 3-wire connection
- 2 2-wire connection

10 Local diagnostic and status indicators

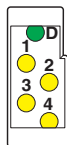

Figure 4 Local diagnostic and status indicators

Designation	Color	Meaning
D	Green	Diagnostics (bus and logic voltage)
1 ... 4	Yellow	Status of the outputs

Function identification

Pink

2 Mbps: White stripe in the vicinity of the D LED

11 Process data

Assignment of the terminal points to the output process data

(Byte.Bit) view	Byte.Bit	0.3	0.2	0.1	0.0
Assignment	Signal	OUT 04	OUT 03	OUT 02	OUT 01
	Terminal point (signal)	2.4	1.4	2.1	1.1
	Terminal point (GND)	2.5	1.5	2.2	1.2
	Terminal point (FE)	2.6	1.6	2.3	1.3
Status indicator	LED	4	3	2	1



For the assignment of the illustrated (byte.bit) view to your INTERBUS control or computer system, please refer to the DB GB IBS SYS ADDRESS data sheet.



SCATTERGOOD & JOHNSON LTD

ELECTRICAL ENGINEERING & FLUID CONTROL DISTRIBUTORS

Est.1899

At Scattergood & Johnson Ltd, we pride ourselves on being a technical distributor to specialist industries.

Working with a range of quality product suppliers across a number of specialist markets, we are not your average 'box shifter' - we are your technical and supply chain partner.

We fully support every product we sell - for free! Our internal team and external sales engineers can answer any product or application question, no matter the complexity.

Backing up this technical ability is a range of 50,000+ products available from stock for nationwide next day delivery (same day if required!), or you can collect what you need from any of our trade counters around the UK.

Select your specialist interest below to learn more about how we can help.



Online, In Branch and On the Road - Scattergood & Johnson Ltd, there when you need us.

www.scatts.co.uk