

# IB IL 24 DO 16...

**Inline, digital output terminal,  
digital outputs: 16, 24 V DC, 500 mA**

Data sheet  
5559\_en\_07

© PHOENIX CONTACT 2018-02-01

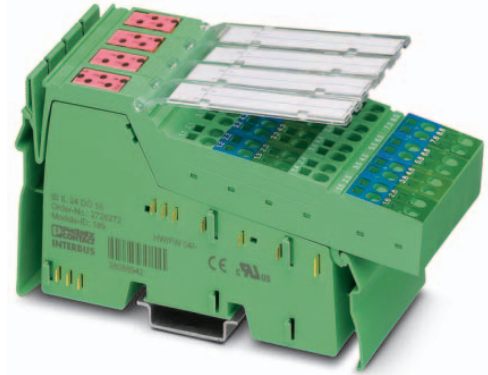

## 1 Description

The terminal is designed for use within an Inline station. It is used to output digital signals.

### Features

- 16 digital outputs
- Connection of actuators in 2 and 3-wire technology
- Nominal current per output: 500 mA
- Total current of the terminal: 8 A
- Short-circuit-proof and overload-protected outputs



#### IB IL 24 DO 16-PAC

**WARNING: Explosion hazard when used in potentially explosive areas**

When using the terminal in potentially explosive areas, observe the corresponding notes.



This data sheet is only valid in association with the IL SYS INST UM E user manual.



Make sure you always use the latest documentation.

It can be downloaded from the product at [phoenixcontact.net/products](http://phoenixcontact.net/products).

---

<b>2</b>	<b>Table of contents</b>	
1	Description .....	1
2	Table of contents .....	2
3	Ordering data .....	3
4	Technical data .....	4
5	Additional tables .....	8
5.1	Output characteristic curve.....	8
5.2	Power dissipation .....	8
5.3	Limitation of simultaneity, derating .....	8
6	Internal circuit diagram .....	9
7	Notes on using the terminal block in potentially explosive areas .....	10
8	Terminal point assignment.....	11
9	Connection notes and examples .....	12
10	Local diagnostic and status indicators .....	12
11	Process data.....	13

### 3 Ordering data

Description	Type	Order No.	Pcs./Pkt.
Inline, digital output terminal, digital outputs: 16, 24 V DC, 500 mA, connection method: 3-conductor, transmission speed in the local bus: 500 kbps, degree of protection: IP20, including Inline connectors and marking fields	IB IL 24 DO 16-PAC	2861292	1
Inline, digital output terminal, digital outputs: 16, 24 V DC, 500 mA, connection method: 3-conductor, transmission speed in the local bus: 500 kbps, degree of protection: IP20, including Inline connectors and marking fields, connectors numbered individually	IB IL 24 DO 16-PAC/SN	2862961	1
Inline, digital output terminal, digital outputs: 16, 24 V DC, 500 mA, connection method: 3-conductor, transmission speed in the local bus: 2 Mbps, degree of protection: IP20, including Inline connectors and marking fields	IB IL 24 DO16-2MBD-PAC	2862013	1
Accessories	Type	Order No.	Pcs./Pkt.
Connector set, for IB IL DO 16, copper, colored identification. (Connector/Adapter)	IB IL DO16-PLSET/OCP	2860992	1
Connector, colored identification, for digital 4, or 16-channel Inline output terminal blocks (Connector/Adapter)	IB IL SCN-12-OCP	2727624	10
Connector, for digital 4 or 16-channel Inline terminals (Connector/Adapter)	IB IL SCN-12	2726340	10
Labeling field, width: 12.2 mm (Marking)	IB IL FIELD 2	2727501	10
Labeling field, width: 48.8 mm (Marking)	IB IL FIELD 8	2727515	10
Insert strip, Sheet, white, unlabeled, can be labeled with: Office printing systems: Laser printer, mounting type: insert, lettering field size: 62 x 10 mm (Marking)	ESL 62X10	0809492	1
Insert strip, Sheet, white, unlabeled, can be labeled with: Office printing systems: Laser printer, mounting type: insert, lettering field size: 62 x 46 mm (Marking)	ESL 62X46	0809502	5
VARIOFACE front adapter for Inline modules, for transferring 16 (2 x 8) digital output signals. (Connector/Adapter)	FLKM 14-PA-INLINE/OUT16	2302764	1
Documentation	Type	Order No.	Pcs./Pkt.
User manual, English, Automation terminals of the Inline product range	IL SYS INST UM E	-	-
Data sheet, English, INTERBUS addressing	DB GB IBS SYS ADDRESS	-	-
Application note, addressing of 16-channel Inline terminals	AH IB IL 24 DI/DO 16 ADDRESS	-	-
Application note, English, Inline terminals for use in zone 2 potentially explosive areas	AH EN IL EX ZONE 2	-	-

## 4 Technical data

### Dimensions (nominal sizes in mm)

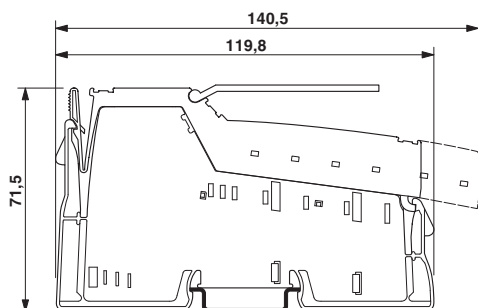

Width	48.8 mm
Height	140.5 mm
Depth	71.5 mm
Note on dimensions	Housing dimensions

### General data

Color	green
Weight	218 g (with connectors)
Operating mode	Process data mode with one word
Ambient temperature (operation)	-25 °C ... 55 °C
Ambient temperature (storage/transport)	-25 °C ... 85 °C
Permissible humidity (operation)	10 % ... 95 % (non-condensing)
Permissible humidity (storage/transport)	10 % ... 95 % (non-condensing)
Air pressure (operation)	70 kPa ... 106 kPa (up to 3000 m above sea level) 80 kPa ... 106 kPa (up to 3000 m above sea level, in ATEX Zone 2)
Air pressure (storage/transport)	70 kPa ... 106 kPa (up to 3000 m above sea level)
Degree of protection	IP20
Protection class	III, IEC 61140, EN 61140, VDE 0140-1

### Connection data: Inline connector

Connection method	Spring-cage connection
Conductor cross section solid / stranded	0.08 mm <sup>2</sup> ... 1.5 mm <sup>2</sup> / 0.08 mm <sup>2</sup> ... 1.5 mm <sup>2</sup>
Conductor cross section [AWG]	28 ... 16
Stripping length	8 mm

### Connection data for UL approvals: Inline connector

Connection method	Spring-cage connection
Conductor cross section solid / stranded	0.2 mm <sup>2</sup> ... 1.5 mm <sup>2</sup> / 0.2 mm <sup>2</sup> ... 1.5 mm <sup>2</sup>
Conductor cross section [AWG]	24 ... 16
Stripping length	8 mm

**Interface: Inline local bus**

Number	2
Connection method	Inline data jumper

**Transmission speed Inline local bus**

IB IL 24 DO 16-PAC	500 kbps
IB IL 24 DO 16-PAC/SN	500 kbps
IB IL 24 DO16-2MBD-PAC	2 Mbps

**Communications power  $U_L$  (500 kbps)**

Supply voltage	7.5 V DC (via voltage jumper)
Current draw	max. 90 mA
Power consumption	max. 0.675 W

**Communications power  $U_L$  (2 Mbps)**

Supply voltage	7.5 V DC (via voltage jumper)
Current draw	max. 105 mA
Power consumption	max. 0.79 W

**Segment circuit supply  $U_S$** 

Supply voltage	24 V DC (via voltage jumper)
Supply voltage range	19.2 V DC ... 30 V DC (including all tolerances, including ripple)
Current draw	max. 8 A

**IB IL 24 DO 16-PAC****WARNING – Explosion hazard when used in ATEX Zone 2**

Make sure that the maximum permissible current of 4 A flowing through potential jumpers  $U_M$  and  $U_S$  (total current) is not exceeded.

**Digital outputs**

Number of outputs	16
Connection method	Spring-cage connection
Connection technology	3-conductor
Nominal output voltage	24 V DC
Voltage difference with nominal current	$\leq 1$ V
Maximum output current per channel	500 mA
Maximum output current per device	8 A
Nominal load, ohmic	12 VA (48 $\Omega$ )
Nominal load, inductive	12 W (1.2 H, 48 $\Omega$ )
Nominal load, lamp	12 W
Signal delay when switching on an ohmic nominal load	typ. 500 $\mu$ s
Signal delay when switching on an inductive nominal load	typ. 100 ms (1.2 H, 48 $\Omega$ )
Signal delay when switching on a lamp nominal load	typ. 100 ms (for switching frequencies up to 8 Hz, above this frequency, the lamp load behaves like an ohmic load)
Signal delay when switching off an ohmic nominal load	typ. 1 ms
Signal delay when switching off an inductive nominal load	typ. 50 ms (1.2 H, 48 $\Omega$ )

<b>Digital outputs</b>	
Signal delay when switching off a lamp nominal load	typ. 1 ms
Maximum operating frequency with ohmic nominal load	max. 300 Hz (this switching frequency is limited by the data rate selected, the number of bus devices, the structure of the bus, the software used and the control or computer system used)
Maximum operating frequency with inductive nominal load	max. 0.5 Hz (1.2 H, 48 $\Omega$ )
Maximum operating frequency with lamp nominal load	max. 8 Hz (this switching frequency is limited by the data rate selected, the number of bus devices, the structure of the bus, the software used and the control or computer system used)
Reaction time with short-circuit	ca. 3 s
Behavior at voltage switch-off	The output follows the power supply without delay
Output data validity	typ. 5 ms (after switching the 24 V voltage supply (power up))
One-time unsolicited energy	400 mJ
Limitation of the voltage induced on circuit interruption	-46 V ... -15 V
Output voltage when switched off	max. 2 V
Output current when switched off	max. 300 $\mu$ A
Behavior with overload	Auto restart
Behavior with inductive overload	Output can be destroyed
Restart frequency with ohmic overload	400 Hz
Restart frequency with lamp overload	400 Hz
Reverse voltage resistance to short pulses	Reverse voltage proof
Resistance to permanent reverse voltage	max. 2 A DC
Overcurrent shut-down	min. 0.7 A
Output current with ground connection interrupt when switched off	max. 25 mA
	typ. 100 mW (at 1 k $\Omega$ load resistance)
Inrush current	max. 1.5 A (at nominal lamp load for 20 ms)
Overload protection, short-circuit protection of outputs	Zener diode in output chip
Note on protection circuit	Channels are thermally coupled in groups of four, i.e., an error in one channel can also affect the other channels.

<b>Programming data (INTERBUS, local bus)</b>	
ID code (hex)	BD
ID code (dec.)	189
Length code (hex)	01
Length code (dec.)	01
Process data channel	16 Bit
Input address area	0 Byte
Output address area	2 Byte
Parameter channel (PCP)	0 Bit
Register length (bus)	16 Bit



For the programming data/configuration data of other bus systems, please refer to the corresponding electronic device data sheet (e.g., GSD, EDS).

**Configuration and parameter data in a PROFIBUS system**

Required parameter data	4 Byte
Need for configuration data	4 Byte

**Error messages to the higher level control or computer system**

Short-circuit / overload of the digital outputs	Error message in the diagnostic code (bus) and display (2 Hz) via the LED (D) on the module
---	---

**Electrical isolation/isolation of the voltage areas**

Test section	Test voltage
7.5 V supply (bus logics)/24 V supply (I/O)	500 V AC, 50 Hz, 1 min.
24 V supply (I/O) / functional earth ground	500 V AC, 50 Hz, 1 min.
7.5 V supply (bus logics) / functional earth ground	500 V AC, 50 Hz, 1 min.



To achieve electrical isolation between the logic level and the I/O area, supply these areas from separate power supply units. Interconnection of the power supply units in the 24 V area is not permitted (see IL SYS INST UM E user manual).

**Approvals**

For the latest approvals, please visit [phoenixcontact.net/products](http://phoenixcontact.net/products).

## 5 Additional tables

### 5.1 Output characteristic curve

Output characteristic curve when switched on (typical)	
Output current (A)	Differential output voltage (V)
0	0
0.1	0.04
0.2	0.08
0.3	0.12
0.4	0,16
0.5	0,20

### 5.2 Power dissipation

#### Formula for calculating the power dissipation of the electronics

- 500 kbps

$$P_{EL} = 0,19 \text{ W} + \sum_{i=1}^n (0,10 \text{ W} + I_{Li}^2 \times 0,40 \Omega)$$

- 2 Mbps

$$P_{EL} = 0,40 \text{ W} + \sum_{i=1}^n (0,10 \text{ W} + I_{Li}^2 \times 0,40 \Omega)$$

Where:

- $P_{EL}$  Total power dissipation in the terminal
- $i$  Continuous index
- $n$  Number of set outputs ( $n = 1 \dots 16$ )
- $I_{Li}$  Load current of output  $i$

#### Power dissipation of the housing

2.7 W maximum (within the permissible operating temperature)

### 5.3 Limitation of simultaneity, derating

Ambient temperature $T_{amb}$	Maximum load current	
	100 % simultaneity	75 % simultaneity
$-25^{\circ}\text{C} \leq T_A < +40^{\circ}\text{C}$	0.50 A	0.50 A
$+40^{\circ}\text{C} \leq T_A < +45^{\circ}\text{C}$	0.45 A	0.50 A
$+45^{\circ}\text{C} \leq T_A < +50^{\circ}\text{C}$	0.40 A	0.50 A
$+50^{\circ}\text{C} < T_A \leq +55^{\circ}\text{C}$	0.35 A	0.50 A



An example for calculating the working point can be found in the user manual IL SYS INST UM E.

## 6 Internal circuit diagram

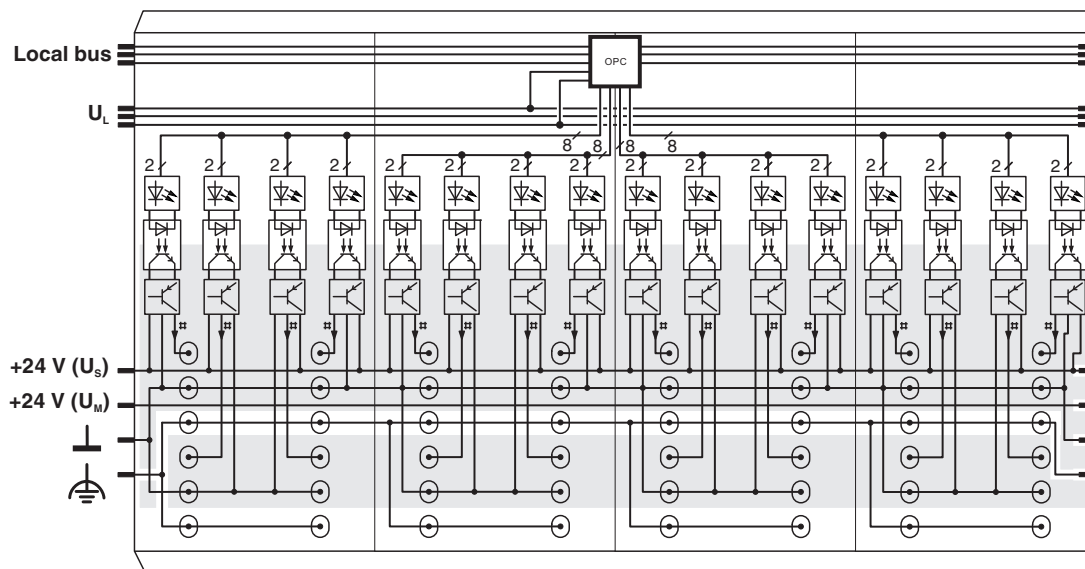









Figure 1 Internal wiring of the terminal points

Key:

-  Protocol chip  
(Bus logic including voltage conditioning)
  -  LED (status indicator)
  -  Optocoupler
  -  Transistor
  -  Digital output
  -  Electrically isolated area
-  Explanation for other used symbols has been provided in the IL SYS INST UM E user manual.

## 7 Notes on using the terminal block in potentially explosive areas

Valid for: IB IL 24 DO 16-PAC



**WARNING: Explosion hazard**

Please make sure that the following notes and instructions are observed.

- When using the device in potentially explosive areas, observe the specifications in the application note AH DE IL EX ZONE 2 (German) / AH EN IL EX ZONE 2 (English).

### Approval according to ATEX Directive 2014/34/EU

Ⓜ II 3 G Ex nA IIC T4 Gc X

### Installation notes

$T_{amb} = -25\text{ °C} \dots +55\text{ °C}$

The category 3 device is designed for installation in zone 2 potentially explosive areas.

The device meets the requirements of EN 60079–0:2012 + A11:2013 and EN 60079–15:2010.

- Observe the specified conditions for use in potentially explosive areas! Also observe the requirements of EN 60079-14.
- Install the device in a suitable approved housing (with at least IP54 protection) that meets the requirements of EN 60079-15.
- Only assemble, disassemble as well as connect and disconnect cables when the power is disconnected.
- Only devices that are designed for operation in Ex Zone 2 and the conditions at the installation location may be connected to the circuits in Zone 2.
- For safe operation, lockable plug connections must have a functional interlock (e. g. locking clip, screw connection etc.). Insert the interlock. Repair any damaged connectors immediately.
- Only connect one cable per terminal point. If you want to connect two flexible cables per terminal point, then use a TWIN ferrule.
- Use transient protection so that short-term surge voltages do not exceed 119 V.
- The air pressure during operation must not exceed 106 kPa.
- Perform a dielectric test after installing the device in the housing.
- For all supply and signal lines connected to the station, make sure that there is a connection to ground potential.
- Make sure that the maximum permissible current of 4 A flowing through potential jumpers  $U_M$  and  $U_S$  (total current) is not exceeded.

## 8 Terminal point assignment

The following applies below:

- A IB IL 24 DO 16-PAC
- B IB IL 24 DO 16-PAC/SN

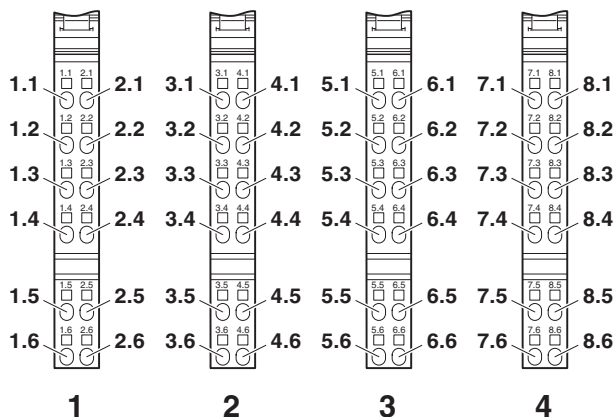

Figure 2 Terminal point assignment (A)

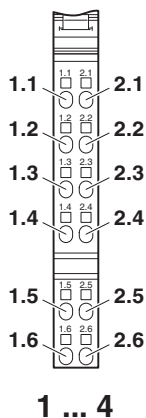

Figure 3 Terminal point assignment (B)

Connector 1		
Terminal point		Assignment
A	B	
1.1 / 2.1		Signal output (OUT01 / OUT02)
1.2 / 2.2		Ground contact (GND)
1.3 / 2.3		FE connection
1.4 / 2.4		Signal output (OUT03 / OUT04)
1.5 / 2.5		Ground contact (GND)
1.6 / 2.6		FE connection

Connector 2		
Terminal point		Assignment
A	B	
3.1 / 4.1	1.1 / 2.1	Signal output (OUT05 / OUT06)
3.2 / 4.2	1.2 / 2.2	Ground contact (GND)
3.3 / 4.3	1.3 / 2.3	FE connection
3.4 / 4.4	1.4 / 2.4	Signal output (OUT07 / OUT08)
3.5 / 4.5	1.5 / 2.5	Ground contact (GND)
3.6 / 4.6	1.6 / 2.6	FE connection

Connector 3		
Terminal point		Assignment
A	B	
5.1 / 6.1	1.1 / 2.1	Signal output (OUT09 / OUT10)
5.2 / 6.2	1.2 / 2.2	Ground contact (GND)
5.3 / 6.3	1.3 / 2.3	FE connection
5.4 / 6.4	1.4 / 2.4	Signal output (OUT11 / OUT12)
5.5 / 6.5	1.5 / 2.5	Ground contact (GND)
5.6 / 6.6	1.6 / 2.6	FE connection

Connector 4		
Terminal point		Assignment
A	B	
7.1 / 8.1	1.1 / 2.1	Signal output (OUT13 / OUT14)
7.2 / 8.2	1.2 / 2.2	Ground contact (GND)
7.3 / 8.3	1.3 / 2.3	FE connection
7.4 / 8.4	1.4 / 2.4	Signal output (OUT15 / OUT16)
7.5 / 8.5	1.5 / 2.5	Ground contact (GND)
7.6 / 8.6	1.6 / 2.6	FE connection

Ground connection (GND): for 2 and 3-conductor connection technology

FE connection: for 3-conductor connection technology

## 9 Connection notes and examples



When connecting the actuators, observe the assignment of the terminal points to the process data.

### IB IL 24 DO 16-PAC, IB IL 24 DO 16-2MBD-PAC

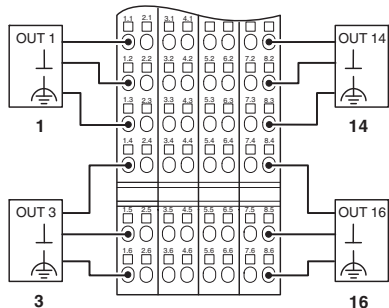

Figure 4 Typical connection of actuators

### IB IL 24 DO 16-PAC/SN

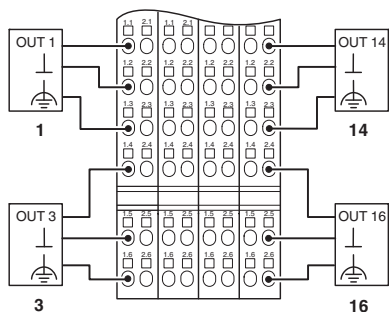

Figure 5 Typical connection of actuators

## 10 Local diagnostic and status indicators

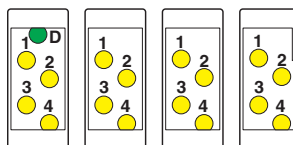

Figure 6 Local diagnostic and status indicators

Designation	Color	Meaning
D	Green	Diagnostics (bus and logic voltage)
<b>For each connector</b>		
1 ... 4	Yellow	Status of the outputs

### Function identification

Pink

2 Mbps: White stripe in the vicinity of the D LED

## 11 Process data

### Assignment of the terminal points to the output process data

The assignment of the process data is shown for the consecutively numbered connectors. It also applies for the individually numbered connectors.

(Word.bit) view	Word	Word 0															
	Bit	15	14	13	12	11	10	9	8	7	6	5	4	3	2	1	0
(Byte.Bit) view	Byte	Byte 0								Byte 1							
	Bit	7	6	5	4	3	2	1	0	7	6	5	4	3	2	1	0
Assignment	Slot	4				3				2				1			
	Signal	OUT 16	OUT 15	OUT 14	OUT 13	OUT 12	OUT 11	OUT 10	OUT 09	OUT 08	OUT 07	OUT 06	OUT 05	OUT 04	OUT 03	OUT 02	OUT 01
	Terminal point (signal)	8.4	7.4	8.1	7.1	6.4	5.4	6.1	5.1	4.4	3.4	4.1	3.1	2.4	1.4	2.1	1.1
	Terminal point (GND)	8.5	7.5	8.2	7.2	6.5	5.5	6.2	5.2	4.5	3.5	4.2	3.2	2.4	1.4	2.2	1.2
	Terminal point (FE)	8.6	7.6	8.3	7.3	6.6	5.6	6.3	5.3	4.6	3.6	4.3	3.3	2.6	1.6	2.3	1.3
Status indicator	LED	4	3	2	1	4	3	2	1	4	3	2	1	4	3	2	1



For the assignment of the illustrated (byte.bit) view to your INTERBUS control or computer system, please refer to the DB GB IBS SYS ADDRESS data sheet.

For the assignment of the illustrated (byte.bit) view to controllers of other bus systems, please refer to the AH IB IL 24 DI/DO 16 ADDRESS document.



# SCATTERGOOD & JOHNSON LTD

ELECTRICAL ENGINEERING & FLUID CONTROL DISTRIBUTORS

Est.1899

At Scattergood & Johnson Ltd, we pride ourselves on being a technical distributor to specialist industries.

Working with a range of quality product suppliers across a number of specialist markets, we are not your average 'box shifter' - we are your technical and supply chain partner.

We fully support every product we sell - for free! Our internal team and external sales engineers can answer any product or application question, no matter the complexity.

Backing up this technical ability is a range of 50,000+ products available from stock for nationwide next day delivery (same day if required!), or you can collect what you need from any of our trade counters around the UK.

Select your specialist interest below to learn more about how we can help.



Online, In Branch and On the Road - Scattergood & Johnson Ltd, there when you need us.

# [www.scatts.co.uk](http://www.scatts.co.uk)