

IB IL AI 2/SF-PAC

**Inline, analog input terminal,
2 inputs for connecting voltage or current signals**

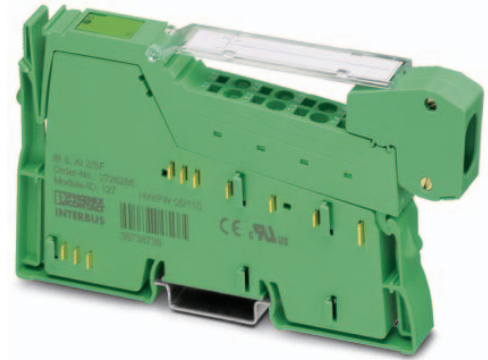

Data sheet
5564_en_06

© PHOENIX CONTACT 2019-03-06

1 Description

The terminal is designed for use within an Inline station. It is used to acquire analog voltage and current signals.

Features

- 2 analog single-ended signal inputs for the connection of either voltage or current signals
- Connection of sensors in 2-wire technology
- Current ranges: 0 mA ... 20 mA, 4 mA ... 20 mA, ± 20 mA
- Voltage ranges: 0 V ... 10 V, ± 10 V
- Channels are parameterized independently of one another via the bus system
- Measured values can be represented in four different formats
- Resolution depends on the representation format and the measuring range
- Process data update of both channels within a max. of 1.5 ms



WARNING: Explosion hazard when used in potentially explosive areas

When using the terminal in potentially explosive areas, observe the corresponding notes.



This data sheet is only valid in association with the IL SYS INST UM E user manual.



Make sure you always use the latest documentation.

It can be downloaded at: phoenixcontact.net/product/2861302

2	Table of contents	
1	Description	1
2	Table of contents	2
3	Ordering data	3
4	Technical data	3
5	Additional technical data.....	6
6	Tolerance data.....	7
	6.1 Tolerance and temperature response of the voltage inputs.....	7
	6.2 Tolerance and temperature response of the current inputs	7
	6.3 Additional tolerances influenced by electromagnetic interference	7
7	Internal circuit diagram	8
8	Electrical isolation.....	8
9	Notes on using the terminal block in potentially explosive areas	9
10	Terminal point assignment.....	10
11	Installation instructions	10
12	Connection notes	10
13	Connection examples	12
	13.1 Connection of active sensors	12
	13.2 Connection of passive sensors.....	12
	13.3 Connecting a battery monitor	12
14	Local diagnostic and status indicators	13
15	Process data.....	14
	15.1 OUT process data.....	14
	15.2 IN process data	15
16	Formats for representing measured values	16
	16.1 IB IL format	16
	16.2 IB ST format	17
	16.3 IB RT format	18
	16.4 Standardized representation format	19
	16.5 Supported error codes for IB IL and standardized representation formats	20
	16.6 Example	20
	16.7 Assignment of the terminal points to IN process data	20

3 Ordering data

Description	Type	Order No.	Pcs./Pkt.
Inline, analog input terminal, analog inputs: 2, 0 V ... 10 V, -10 V ... 10 V, 0 mA ... 20 mA, 4 mA ... 20 mA, -20 mA ... 20 mA, connection method: 2-wire, transmission speed in the local bus: 500 kbps, degree of protection: IP20, including Inline connector and labeling field	IB IL AI 2/SF-PAC	2861302	1
Accessories	Type	Order No.	Pcs./Pkt.
Inline shield connector (Connector/Adapter)	IB IL SCN 6-SHIELD-TWIN	2740245	5
Labeling field, width: 12.2 mm (Marking)	IB IL FIELD 2	2727501	10
Insert strip, Sheet, white, unlabeled, can be labeled with: Office printing systems: Laser printer, mounting type: insert, lettering field size: 62 x 10 mm (Marking)	ESL 62X10	0809492	1
Inline shield connector (Connector/Adapter)	IB IL SCN-6 SHIELD	2726353	5
Documentation	Type	Order No.	Pcs./Pkt.
User manual, English, Automation terminals of the Inline product range	IL SYS INST UM E	-	-
Data sheet, English, INTERBUS addressing	DB GB IBS SYS ADDRESS	-	-
Application note, English, Inline terminals for use in zone 2 potentially explosive areas	AH EN IL EX ZONE 2	-	-

4 Technical data

Dimensions (nominal sizes in mm)

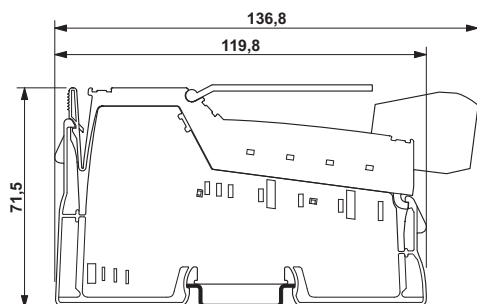

Width	12.2 mm
Height	136.8 mm
Depth	71.5 mm
Note on dimensions	Housing dimensions

General data	
Color	green
Weight	69 g (with connector)
Operating mode	Process data operation with 2 words
Ambient temperature (operation)	-25 °C ... 55 °C
Ambient temperature (storage/transport)	-25 °C ... 85 °C
Permissible humidity (operation)	10 % ... 95 % (non-condensing)
Permissible humidity (storage/transport)	10 % ... 95 % (non-condensing)
Air pressure (operation)	70 kPa ... 106 kPa (up to 3000 m above sea level) 80 kPa ... 106 kPa (up to 3000 m above sea level, in ATEX Zone 2)
Air pressure (storage/transport)	70 kPa ... 106 kPa (up to 3000 m above sea level)
Degree of protection	IP20
Protection class	III, IEC 61140, EN 61140, VDE 0140-1
Connection data: Inline connector	
Connection method	Spring-cage connection
Conductor cross section solid / stranded	0.08 mm ² ... 1.5 mm ² / 0.08 mm ² ... 1.5 mm ²
Conductor cross section [AWG]	28 ... 16
Stripping length	8 mm
Connection data for UL approvals: Inline connector	
Connection method	Spring-cage connection
Conductor cross section solid / stranded	0.2 mm ² ... 1.5 mm ² / 0.2 mm ² ... 1.5 mm ²
Conductor cross section [AWG]	24 ... 16
Stripping length	8 mm
Interface: Inline local bus	
Number	2
Connection method	Inline data jumper
Transmission speed	500 kbps
Communications power (U_L)	
Supply voltage	7.5 V DC (via voltage jumper)
Current draw	typ. 45 mA max. 60 mA
Supply of analog modules (U_{ANA})	
Supply voltage	24 V DC (via voltage jumper)
Supply voltage range	19.2 V DC ... 30 V DC (including all tolerances, including ripple)
Current draw	typ. 13 mA max. 18 mA
Power consumption	
Power consumption	typ. 662 mW max. 882 mW

Analog inputs	
Number of inputs	2
Description of the input	Single-ended inputs, voltage or current
Connection method	Inline shield connector
Connection technology	2-wire, shielded
Current input signal	0 mA ... 20 mA, 4 mA ... 20 mA, -20 mA ... 20 mA
Voltage input signal	0 V ... 10 V, -10 V ... 10 V
Max. permissible current	± 100 mA (Current inputs)
A/D conversion time	typ. 120 µs (per channel)
Measured value representation	16 bit two's complement
Data formats	IB IL, IB ST, IB RT, standardized representation
Averaging	Over 16 measured values (can be switched off)
Process data update	< 1.5 ms (The time includes the internal firmware runtime and the time for the analog-to-digital conversion. For system considerations (e.g., for the step response determination of sensors), please take into account additional times for latching and bus transmission as well as the status of mean-value generation.)
Input resistance of voltage input	> 220 kΩ
Input resistance current input	50 Ω (Shunt)
Limit frequency (3 dB)	40 Hz
Open circuit response	Countering 0 V, 0 mA or 4 mA, an open circuit message is issued in the process data from <3.2 mA in the measuring range of 4 mA ... 20 mA
Permissible voltage	max. ± 32 V (between analog voltage inputs and analog reference potential) max. ± 5 V (between analog current inputs and analog reference potential, correspond to 100 mA through the shunts)
Common mode voltage range	40 V (between current input and functional earth ground) 40 V (between voltage input and functional ground)
Common mode rejection (CMR)	min. 90 dB (Current and voltage input signal, valid for approved DC common-mode voltage range) typ. 110 dB (Current and voltage input signal, valid for approved DC common-mode voltage range)
Surge protection	Suppressor diodes in the analog inputs
Programming data (INTERBUS, local bus)	
ID code (hex)	7F
ID code (dec.)	127
Length code (hex)	02
Length code (dec.)	02
Process data channel	32 Bit
Input address area	4 Byte
Output address area	4 Byte

Programming data (INTERBUS, local bus)

Parameter channel (PCP)	0 Byte
Register length (bus)	32 Bit



For the programming data/configuration data of other bus systems, please refer to the corresponding electronic device data sheet (e.g., GSD, EDS).

Configuration and parameter data in a PROFIBUS system

Required parameter data	6 Byte
Required configuration data	4 Byte

Error messages to the higher level control or computer system

Failure of the internal I/O supply	Yes
Peripheral fault	Error message in the process data
User error	Error message in the process data

Electrical isolation/isolation of the voltage areas

Test section	Test voltage
7.5 V supply (bus logic), 24 V supply U_{ANA} / I/O	500 V AC, 50 Hz, 1 min.
7.5 V supply (bus logic), 24 V supply U_{ANA} /functional earth ground	500 V AC, 50 Hz, 1 min.
I/O / functional earth ground	500 V AC, 50 Hz, 1 min.

Approvals

For the latest approvals, please visit phoenixcontact.net/products.

5 Additional technical data

The following data deviates from the specifications in the user manual IL SYS INST UM.

Mechanical tests

Shock in acc. with EN 60068-2-27/IEC 60068-2-27	15g load for 11 ms, half sinusoidal wave, three shocks per space direction and orientation 25g load for 6 ms, half sinusoidal wave, three shocks per space direction and orientation
---	---

Immunity test in accordance with EN 61000-6-2

Electrostatic discharge (ESD) EN 61000-4-2 / IEC 61000-4-2	Criterion B; 6 kV contact discharge; 6 kV air discharge
--	---

6 Tolerance data

6.1 Tolerance and temperature response of the voltage inputs

The tolerance indications relate to the measuring range final value of 10 V.

	Typical	Maximum
Tolerance at 23°C		
Tolerance through offset	±0.03%	±0.06%
Tolerance through gain	±0.05 %	±0.10%
Differential non-linearity	±0.10%	±0.20 %
Total tolerance	±0.15 %	±0.30%
Temperature and drift response (T_A = -25°C ... +55°C)		
Offset voltage drift T _{KVO}	±6 ppm/K	±12 ppm/K
Gain drift T _{KG}	±30 ppm/K	±50 ppm/K
Total voltage drift T _{Ktot} = T _{KVO} + T _{KG}	±36 ppm/K	±62 ppm/K
Total tolerance (tolerance through offset, gain, linearity, and drift)	±0.30%	±0.50 %

6.2 Tolerance and temperature response of the current inputs

The tolerance indications relate to the measuring range final value of 20 mA.

	Typical	Maximum
Tolerance at 23°C		
Tolerance through offset	±0.03%	±0.06%
Tolerance through gain	±0.10%	±0.10%
Differential non-linearity	±0.10%	±0.30%
Total tolerance	±0.20 %	±0.40 %
Temperature and drift response (T_A = -25°C ... +55°C)		
Offset current drift T _{KIO}	±6 ppm/K	±12 ppm/K
Gain drift T _{KG}	±30 ppm/K	±50 ppm/K
Total current drift T _{Ktot} = T _{KIO} + T _{KG}	±36 ppm/K	±62 ppm/K
Total tolerance (tolerance through offset, gain, linearity, and drift)	±0.35 %	±0.60 %

6.3 Additional tolerances influenced by electromagnetic interference

Type of electromagnetic interference		Typical deviation from the measuring range final value (voltage input)		Typical deviation of the measuring range final value (current input)	
		Relative	Absolute	Relative	Absolute
Electromagnetic fields	EN 61000-4-3/ IEC 61000-4-3	< ±2.0 %	< ±200 mV	< ±2.0 %	< ±400 µA
Fast transients (burst)	EN 61000-4-4/ IEC 61000-4-4	< ±1.0 %	< ±100 mV	< ±1.0 %	< ±100 µA
Conducted interference	EN 61000-4-6/ IEC 61000-4-6	< ±1.0 %	< ±100 mV	< ±1.0 %	< ±100 µA

7 Internal circuit diagram

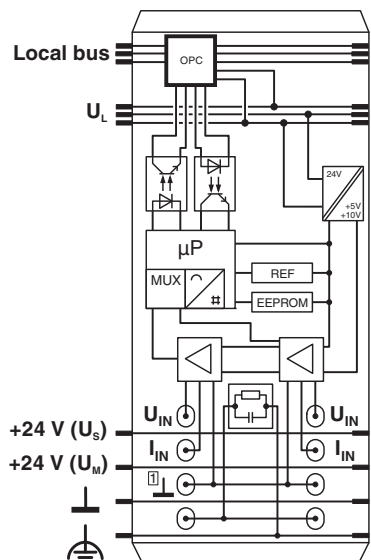











Figure 1 Internal wiring of the terminal points

Key:

-  Protocol chip
 -  Optocoupler
 -  Power supply unit with electrical isolation
 -  Microprocessor with multiplexer and analog-to-digital converter
 -  Reference voltage source
 -  Electrically erasable programmable read-only memory
 -  Input amplifier
 -  Coupling network
-  Please refer to the IL SYS INST UM E user manual for an explanation of other symbols used.

8 Electrical isolation

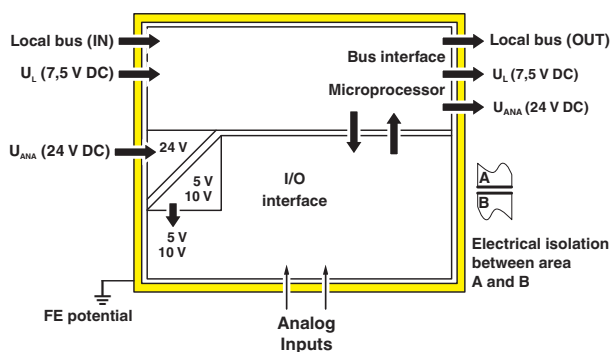

Figure 2 Electrical isolation of the individual function areas

9 Notes on using the terminal block in potentially explosive areas



WARNING: Explosion hazard

Please make sure that the following notes and instructions are observed.

Approval according to ATEX Directive 2014/34/EU

Ⓜ II 3 G Ex nA IIC T4 Gc X

Installation notes

$T_{amb} = -25\text{ °C} \dots +55\text{ °C}$

The category 3 device is designed for installation in zone 2 potentially explosive areas.

The device meets the requirements of EN 60079–0 and EN 60079–15.

- Observe the specified conditions for use in potentially explosive areas! Also observe the requirements of EN 60079-14.
- Install the device in a suitable approved housing (with at least IP54 protection) that meets the requirements of EN 60079-15.
- Only assemble, disassemble as well as connect and disconnect cables when the power is disconnected.
- Only devices that are designed for operation in Ex Zone 2 and the conditions at the installation location may be connected to the circuits in Zone 2.
- For safe operation, lockable plug connections must have a functional interlock (e. g. locking clip, screw connection etc.). Insert the interlock. Repair any damaged connectors immediately.
- Only connect one cable per terminal point.
- Use transient protection so that short-term surge voltages do not exceed 119 V.
- The air pressure during operation must not exceed 106 kPa.
- Perform a dielectric test after installing the device in the housing.
- For all supply and signal lines connected to the station, make sure that there is a connection to ground potential.
- Make sure that the maximum permissible current of 4 A flowing through potential jumpers U_M and U_S (total current) is not exceeded.
- When using the device in potentially explosive areas, observe the specifications in the application note AH DE IL EX ZONE 2 (German) / AH EN IL EX ZONE 2 (English).

10 Terminal point assignment

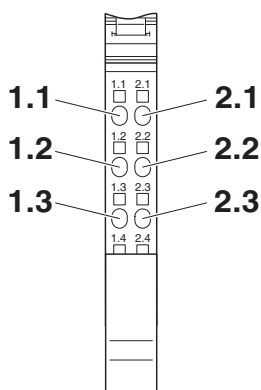

Figure 3 Terminal point assignment

Terminal point	Signal	Meaning
1.1	U1+	Voltage input, channel 1
2.1	U2+	Voltage input, channel 2
1.2	I1+	Current input, channel 1
2.2	I2+	Current input, channel 2
1.3	U1-/I1-	Minus input, channel 1 (common for current and voltage)
2.3	U2-/I2-	Minus input, channel 2 (common for current and voltage)
1.4, 2.4	Shield	Shield connection

11 Installation instructions

High current flowing through potential jumpers U_M and U_S leads to a temperature rise in the potential jumpers and inside the terminal. To keep the current flowing through the potential jumpers of the analog terminals as low as possible, always place the analog terminals after all the other terminals at the end of the main circuit (for the sequence of the Inline terminals: see also IL SYS INST UM E user manual).

12 Connection notes



WARNING: invalid measured values

Do not apply current and voltage signals to one input channel simultaneously as you will not obtain valid measured values.



NOTE: Damage to the electronics

Do not connect voltages above ± 5 V to a current input. The module electronics will be damaged, as the maximum permissible current of ± 100 mA will be exceeded.

Always connect the analog sensors using shielded, twisted pair cables.

Connect the shielding to the terminal via the shield connection clamp. Via the clamp, the shield is connected with high resistance and capacitance to FE on the module side. Additional wiring is not required.

Connect the shield of the sensor with PE potential.

Supply passive sensors using an external power supply unit or an additional segment terminal with a fuse. See "Connection examples".

Within the terminal, the ground is connected to FE via an RC element.

If you want to use **both** channels of the terminal, you have various options to connect the shielding, depending on how the cables are routed.

Connection of sensors using a multi-wire bus cable

- Remove the outer sheath of the bus cable at the required point and close the shield to the Inline terminal via the shield connection clamp of the shield plug (A).
- Route the bus cable to the sensors (B).

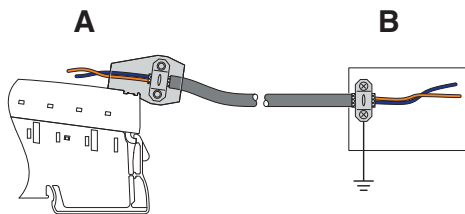

Figure 4 Connection of analog sensors using a multi-wire bus cable

Connection of sensors via separate cables

To protect against ground loops, close the sensors via separate sensor cables as follows:

- Install a busbar with a connection to the ground potential in front of the Inline terminal (B).
- Remove the outer sheath of the bus cable at the required point and connect the shield using an appropriate shield clamp.
- Please note that the busbar must be the only point in the wiring at which the shield is connected with the ground potential.
- Continue to route the sensor cables to the Inline terminal. Close the shield via the shield connection clamp of the shield plug (A).
- Route the sensor cable to the sensor, making sure to maintain cable insulation (C).
- Repeat this procedure for the second sensor cable.

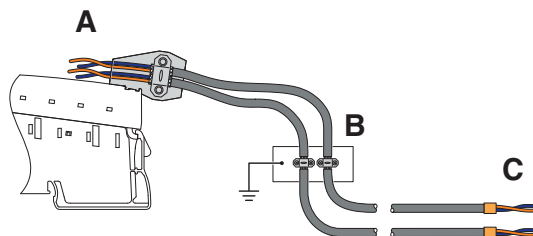

Figure 5 Connection of two analog sensors with separate cables

13 Connection examples

13.1 Connection of active sensors

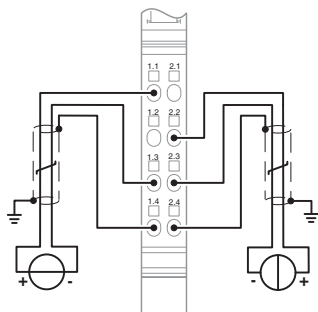

Figure 6 Connection of active sensors in 2-wire technology with shield connection

Left: Active sensor with voltage input (channel 1)
 Right: Active sensor with current input (channel 2)

13.2 Connection of passive sensors

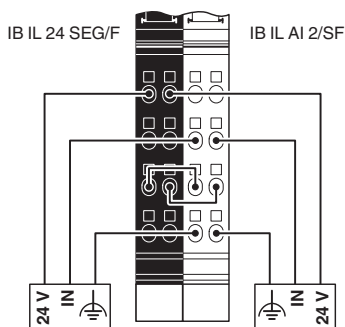

Figure 7 Connection of passive sensors in 2-wire technology with shield connection

The passive sensor supply is indicated in the figure using an upstream segment terminal with fuse.
 As an alternative, you can supply the sensors via an external power supply unit.

13.3 Connecting a battery monitor



NOTE: Short-circuit

Both reference inputs (minus inputs) of each terminal are connected to each other. If signal sources are connected in series, incorrect connections can lead to a short circuit of individual signal sources.

- Observe the following connection example for series connection.

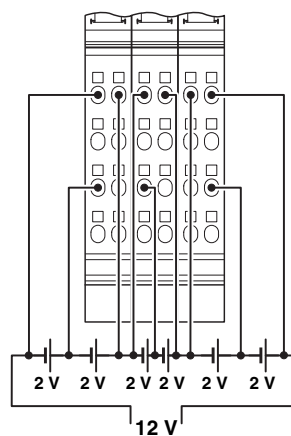

Figure 8 Typical connection for battery monitoring

Because of the single-ended inputs, wire the series connection as follows:

Connect the reference input of one terminal between two voltage sources.

Channel 1 measures the first voltage source with opposite polarity. Adjust the polarity of the measured value in the controller.

Channel 2 measures the second voltage source with correct polarity.

Parameterize the terminal to bipolar ($\pm 10\text{ V}$).

14 Local diagnostic and status indicators

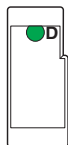

Figure 9 Local diagnostic and status indicators

Designation	Color	Meaning
D	Green	Diagnostics (bus and logic voltage)



For detailed information on diagnostics, please refer to the IL SYS INST UM E user manual.

Function identification

Green

15 Process data

The terminal uses two words of IN process data and two words of OUT process data.

Each channel is mapped to a word.

The analog values are transmitted via the input process data.

You can parameterize the terminal channel by channel via the OUT process data.

15.1 OUT process data

You can parameterize each channel independently of the other channels. Parameterize the first channel via the first output word (OUT0), and the second channel via the second output word (OUT1).

The following parameterization options are available:

- Selecting the measuring range according to the input signal
- Switching off mean-value generation (filter)
- Selecting the formats for representing measured values

The parameterization is not saved. Transmit the parameterization in each bus cycle.

After applying voltage (power up) to the Inline station, the message "Measured value invalid" (error code 8004_{hex}) appears in the process data input words. After a maximum of one second, the preset parameterization is accepted and the first measured value is available.

If you change the parameterization, the corresponding channel is re-initialized.

The message "Measured value invalid" (error code 8004_{hex}) appears in the process data output words for maximum 100 ms.

The following values are preset on the terminal:

Measuring range	0 V ... 10 V
Mean-value generation	16-sample mean-value
Format	IB IL



You cannot switch the signal inputs via the OUT process data. Select the current or voltage measurement by applying the measuring signal at the current or voltage input. In addition, select the corresponding measuring range via the OUT process data.

Order of the process data words:

OUT00	OUT01
Channel 1	Channel 2

Assignment of the parameter words (OUT00 and OUT01)

	15	14	13	12	11	10	9	8	7	6	5	4	3	2	1	0
Parameterization	0	0	0	0	0	0	Filter	0	0	0	0	Format	Measuring range			

Bit 15

Code (bin)		Parameterization
dec	bin	
0	0	Default
1	1	Parameterization

When bit 15 = 0, the preset (default) is active.

In order to parameterize the terminal, set bit 15 to 1.

Bit 9 ... 8

Code		Filter
dec	bin	
0	00	16-sample mean-value (default)
1	01	No filter
2	10	Reserved
3	11	Reserved

Bit 5 ... 4

Code		Format (data format)	
dec	bin		
0	00	IB IL (default)	15 bits + sign bit
1	01	IB ST	12 bits + sign bit
2	10	IB RT	15 bits + sign bit
3	11	Standardized representation	15 bits + sign bit

See also Section "Measured value representation in the different formats".

Bit 3 ... 0

Code		Measuring range
dec	bin	
0	0000	0 V ... 10 V (default)
1	0001	-10 V ... +10 V
8	1000	0 mA ... 20 mA
9	1001	-20 mA ... +20 mA
10	1010	4 mA ... 20 mA
Other		Reserved



Set all reserved bits to 0.

15.2 IN process data

The measured values and diagnostic messages (in the formats IB IL and standardized representation) are transmitted channel-by-channel to the controller via the process data input words IN00 and IN01.

Order of the process data words:

IN00	IN01
Channel 1	Channel 2

16 Formats for representing measured values



Phoenix Contact recommends format IB IL for all controllers as this format contains the most comprehensive diagnostic codes.

The other formats are only intended for simplifying reconfiguration on IB IL analog modules in existing projects.

16.1 IB IL format

The measured value is represented in bits 14 to 0.

An additional bit (bit 15) is available as a sign bit.

This format supports extended diagnostics. Values $> 8000_{\text{hex}}$ and $< 8100_{\text{hex}}$ indicate an error.

The error codes are specified in the section "Supported IB IL error codes and standardized representation".

Measured value representation in IB IL format

15	14	13	12	11	10	9	8	7	6	5	4	3	2	1	0
V	Analog value														

V Sign bit

Significant measured values

Input data		0 V ... 10 V	± 10 V	0 mA ... 20 mA	± 20 mA	4 mA ... 20 mA
hex	dec	V	V	mA	mA	mA
8001	Overrange	$> +10.837$	$> +10.837$	$> +21.6746$	$> +21.6746$	$> +21.3397$
7F00	32512	$+10.837$	$+10.837$	$+21.6746$	$+21.6746$	$+21.3397$
7530	30000	$+10.0$	$+10.0$	$+20.0$	$+20.0$	$+20.0$
0001	1	$+333.33 \mu\text{V}$	$+333.33 \mu\text{V}$	$+0.66667 \mu\text{A}$	$+0.66667 \mu\text{A}$	$+4.0005333$
0000	0	≤ 0	0	≤ 0	0	$+4.0 \dots +3.2$
FFFF	-1		$-333.33 \mu\text{V}$		$-0.66667 \mu\text{A}$	
8AD0	-30000		-10.0		-20.0	
8100	-32512		-10.837		-21.6746	
8080	Underrange		< -10.837		< -21.6746	
8002	Open circuit					

16.2 IB ST format

The measured value is represented in bits 14 to 3.

An additional bit (bit 15) is available as a sign bit.

Bits 2 to 0 are measuring range and error bits.

IB ST format corresponds to the data format used on INTERBUS ST modules.

Measured value representation in IB ST format

15	14	13	12	11	10	9	8	7	6	5	4	3	2	1	0
V	Analog value												0/4	OC	BÜ

V	Sign bit
OC	Open circuit
BÜ	Overrange
0/4	4 mA ... 20 mA measuring range

Significant measured values

Input data		0 V ... 10 V	± 10 V	0 mA ... 20 mA	± 20 mA
hex	dec	V	V	mA	mA
7FF9	Overrange	> +10.75	> +10.75	> +21.5	> +21.5
7FF8	32760	+10.0 ... 10.75	+10.0 ... 10.75	+20.0 ... +21.5	+20.0 ... +21.5
7FF8	32760	+9.9975	+9.9975	+19.9951	+19.9951
4000	16384	+5.0	+5.0	+10.0	+10.0
0008	8	+0.002441	+0.002441	+0.0048828	+0.0048828
0000	0	≤ 0	0	≤ 0	0
FFF8	-8		-0.002441		-0.0048828
8000	-32768		-10.0 ... -10.75		-20.0 ... -21.5
8001	-32767		> -10.75		< -21.5
8002	Open circuit				

Input data		4 mA ... 20 mA
hex	dec	mA
7FFD	Overrange	> +21.5
7FFC	32764	+20.0 ... +21.5
7FFC	32764	+19.9961
4004	16388	+12.0
000C	12	+4.003906
0004	4	+4.0 ... +3.2
0006	Open circuit	< +3.2

16.3 IB RT format

The measured value is represented in bits 14 to 0.

An additional bit (bit 15) is available as a sign bit.

IB RT format corresponds to the data format used on INTERBUS RT modules.

Error codes and error bits are not defined in this data format. The positive final value $7FFF_{\text{hex}}$ indicates an open circuit.

Measured value representation in IB RT format

15	14	13	12	11	10	9	8	7	6	5	4	3	2	1	0
V	Analog value														

V Sign bit

Significant measured values

Input data		0 V ... 10 V	± 10 V	0 mA ... 20 mA	± 20 mA	4 mA ... 20 mA
hex	dec	V	V	mA	mA	mA
7FFF	32767	≥ +9.999695	≥ +9.999695	≥ +19.999385	≥ +19.999385	≥ 19.9995116
7FFE	32766	+9.999695		+19.9987745		+19.9990232
7FF7	32759		+9.999695		+19.998779	
4000	16384	+5.0	+5.0	+10.0	+10.0	+12.0
0001	1	+305.0 μV	+305.0 μV	+0.6105 μA	+0.61035 μA	+0.4884 μA
0000	0	≤ 0	0	≤ 0	0	+4.0
FFFF	-1		-305.0 μV		-0.61035 μA	+4.0 ... +3.2
8001	-32676		-9.99939		-19.999389	
7FFF	-32767					< +3.2
8000	-32768		≤ -10.0		≤ -20.0	

16.4 Standardized representation format

The measured value is represented in bits 14 to 0.

An additional bit (bit 15) is available as a sign bit.

In this format, data is standardized to the measuring range and represented in such a way that it indicates the corresponding value without conversion. In this format, one bit has the value of 1 mV or 1 μ A.

This format supports extended diagnostics. Values $> 8000_{\text{hex}}$ and $< 8100_{\text{hex}}$ indicate an error.

The error codes are specified in the section "Supported IB IL error codes and standardized representation".

Measured value representation in standardized representation format

15	14	13	12	11	10	9	8	7	6	5	4	3	2	1	0
V	Analog value														

V Sign bit

Significant measured values



Due to the standardized representation not all of the possible codes are used. In addition, some codes are used for diagnostic functions. Therefore, the resolution is not 15 bits but exactly 13.287713 bits.

Input data		0 V ... 10 V	± 10 V	0 mA ... 20 mA	± 20 mA	4 mA ... 20 mA
hex	dec	V	V	mA	mA	mA
8001	Overrange	$> +10.837$	$> +10.837$	$> +21.6747$	$> +21.6747$	$> +21.3397$
4E20	20000	-	-	+20.0	+20.0	-
3E80	16000	-	-	+16.0	+16.0	+20.0
2710	10000	+10.0	+10.0	+10.0	+10.0	+14.0
1388	5000	+5.0	+5.0	+5.0	+5.0	+9.0
0001	1	+0.001	+0.001	+0.001	+0.001	+4.001
0000	0	≤ 0	0	≤ 0	0	+4.0 ... +3.2
FFFF	-1		-0.001		-0.001	
EC78	-5000		-5.0		-5.0	
D8F0	-10000		-10.0		-10.0	
8080	Underrange		< -10.837		< -21.6747	
8002	Open circuit				$< +3.2$	

16.5 Supported error codes for IB IL and standardized representation formats

In IB IL and standardized representation formats, a diagnostics code is mapped in the event of an error.

Code (hex)	Cause
8001	Measuring range exceeded (overrange)
8002	Open circuit
8004	Measured value is invalid
8010	Configuration invalid
8020	Sensor and/or analog supply not present
8040	Device faulty
8080	Below measuring range (underrange)

16.6 Example

Measured value representation in different data formats

Measuring range 0 mA ... 20 mA
 Measured value 10 mA

Format	Value		Measured value
	hex	dec	
IB IL	3A98	15000	10 mA
IB ST	4000	16384	10 mA
IB RT	4000	16384	10 mA
Standardized representation	2710	10000	10 mA

16.7 Assignment of the terminal points to IN process data

(Word.bit) view	Word	Word x															
		Bit	15	14	13	12	11	10	9	8	7	6	5	4	3	2	1
(Byte.Bit) view	Byte	Byte 0								Byte 1							
		Bit	7	6	5	4	3	2	1	0	7	6	5	4	3	2	1
Channel 1	Signal	Terminal point 1.1: voltage input Terminal point 1.2: current input															
	Signal reference	Terminal point 1.3															
	Shielding	Terminal point 1.4															
Channel 2	Signal	Terminal point 2.1: voltage input Terminal point 2.2: current input															
	Signal reference	Terminal point 2.3															
	Shielding	Terminal point 2.4															

Word x	Channel
IN00	1
IN01	2



SCATTERGOOD & JOHNSON LTD

ELECTRICAL ENGINEERING & FLUID CONTROL DISTRIBUTORS

Est.1899

At Scattergood & Johnson Ltd, we pride ourselves on being a technical distributor to specialist industries.

Working with a range of quality product suppliers across a number of specialist markets, we are not your average 'box shifter' - we are your technical and supply chain partner.

We fully support every product we sell - for free! Our internal team and external sales engineers can answer any product or application question, no matter the complexity.

Backing up this technical ability is a range of 50,000+ products available from stock for nationwide next day delivery (same day if required!), or you can collect what you need from any of our trade counters around the UK.

Select your specialist interest below to learn more about how we can help.



Online, In Branch and On the Road - Scattergood & Johnson Ltd, there when you need us.

www.scatts.co.uk