

IB IL AO 1/SF-PAC

Inline, analog output terminal with one analog output

Data sheet
5562_en_07

© PHOENIX CONTACT 2017-11-06

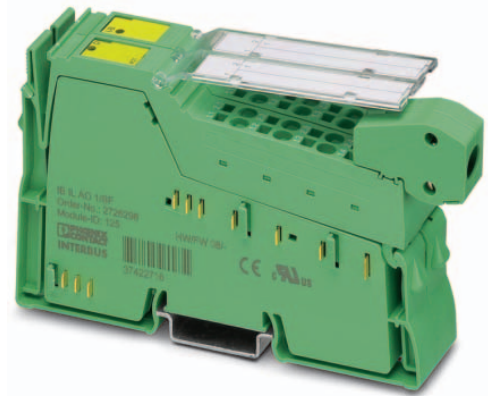

1 Description

The terminal is designed for use within an Inline station. It is used to output analog current and voltage signals.

Features

- 1 analog output for the connection of either voltage or current signals
- Connection of actuators in 2-wire technology
- Current ranges: 0 mA ... 20 mA, 4 mA ... 20 mA
- Voltage range: 0 V ... 10 V
- Process data update including conversion time of the digital/analog converter < 1 ms



NOTE: Terminal overheating

- Only assign one output to the terminal.
- Connect the actuator via the shield plug.



WARNING: Explosion hazard when used in potentially explosive areas

When using the terminal in potentially explosive areas, observe the corresponding notes.



This data sheet is only valid in association with the IL SYS INST UM E user manual.



Make sure you always use the latest documentation. It can be downloaded from the product at phoenixcontact.net/products.

2	Table of contents	
1	Description	1
2	Table of contents	2
3	Ordering data	3
4	Technical data	4
5	Additional technical data.....	7
	5.1 Mechanical requirements.....	7
	5.2 Derating	7
	5.3 Tolerance specifications.....	7
6	Internal circuit diagram	10
7	Electrical isolation.....	10
8	Notes on using the terminal block in potentially explosive areas	11
9	Terminal point assignment.....	11
10	Connection examples	12
11	Connection notes	12
12	Installation instructions	12
13	Local diagnostic and status indicators	13
14	Process data.....	13
15	Significant values.....	14
16	Output behavior	15

3 Ordering data

Description	Type	Order No.	Pcs./Pkt.
Inline, Analog output terminal, Analog output: 1, 0 V ... 10 V, 0 mA ... 20 mA, 4 mA ... 20 mA, connection method: 2-wire, transmission speed in the local bus: 500 kbps, degree of protection: IP20, including Inline connectors and marking fields	IB IL AO 1/SF-PAC	2861315	1
Accessories			
Connector set (Connector/Adapter)	IB IL AO/CNT-PLSET	2732664	1
Labeling field, width: 12.2 mm (Marking)	IB IL FIELD 2	2727501	10
Insert strip, Sheet, white, unlabeled, can be labeled with: Office printing systems: Laser printer, mounting type: insert, lettering field size: 62 x 10 mm (Marking)	ESL 62X10	0809492	1
Inline shield connector (Connector/Adapter)	IB IL SCN-6 SHIELD	2726353	5
Connector, for digital 1, 2 or 8-channel Inline terminals (Connector/Adapter)	IB IL SCN-8	2726337	10
Inline connector, colored (Connector/Adapter)	IB IL SCN-8-CP	2727608	10
Zack Marker strip, flat, Strip, white, unlabeled, can be labeled with: CMS-P1-PLOTTER, PLOTMARK, mounting type: snap into flat marker groove, for terminal block width: 6.2 mm, lettering field size: 5.15 x 6.15 mm (Marking)	ZBF 6:UNBEDRUCKT	0808710	10
Zack Marker strip, flat, white, for terminal block width: 6.2 mm (Marking)	ZBF 6:SO/CMS	0808778	1
Flat zack marker sheet, white, for terminal block width: 6.2 mm (Marking)	ZBFM 6:SO/CMS	0803650	1
Flat zack marker sheet, Sheet, white, unlabeled, can be labeled with: CMS-P1-PLOTTER, PLOTMARK, mounting type: snap into flat marker groove, for terminal block width: 6.2 mm, lettering field size: 5 x 5.5 mm (Marking)	ZBFM 6/WH:UNBEDRUCKT	0803618	10
Marker pen without ink cartridge, for manual labeling of markers, labeling extremely wipe-proof, line thickness 0.35 mm (Marking)	X-PEN 0,35	0811228	1
Marker pen, for manual labeling of unprinted Zack strips, smear-proof and waterproof, line thickness 0.5 mm (Marking)	B-STIFT	1051993	10
Documentation			
User manual, English, Automation terminals of the Inline product range	IL SYS INST UM E	-	-
Data sheet, English, INTERBUS addressing	DB GB IBS SYS ADDRESS	-	-
Application note, English, Inline terminals for use in zone 2 potentially explosive areas	AH EN IL EX ZONE 2	-	-

4 Technical data

Dimensions (nominal sizes in mm)

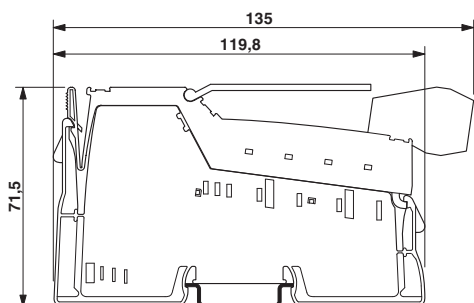

Width	24.4 mm
Height	135 mm
Depth	71.5 mm
Note on dimensions	Housing dimensions

General data

Color	green
Weight	126 g (with connectors)
Operating mode	Process data mode with one word
Ambient temperature (operation)	-25 °C ... 55 °C
Ambient temperature (storage/transport)	-25 °C ... 85 °C
Permissible humidity (operation)	10 % ... 95 % (non-condensing)
Permissible humidity (storage/transport)	10 % ... 95 % (non-condensing)
Air pressure (operation)	70 kPa ... 106 kPa (up to 3000 m above sea level) 80 kPa ... 106 kPa (up to 3000 m above sea level, in ATEX Zone 2)
Air pressure (storage/transport)	70 kPa ... 106 kPa (up to 3000 m above sea level)
Degree of protection	IP20
Protection class	III, IEC 61140, EN 61140, VDE 0140-1

Connection data

Designation	Inline connector
Connection method	Spring-cage connection
Conductor cross section solid / stranded	0.08 mm ² ... 1.5 mm ² / 0.08 mm ² ... 1.5 mm ²
Conductor cross section [AWG]	28 ... 16
Stripping length	8 mm

Connection data for UL approvals

Designation	Inline connector
Connection method	Spring-cage connection
Conductor cross section solid / stranded	0.2 mm ² ... 1.5 mm ² / 0.2 mm ² ... 1.5 mm ²
Conductor cross section [AWG]	24 ... 16
Stripping length	8 mm

Interface: Inline local bus

Number	2
Connection method	Inline data jumper
Transmission speed	500 kbps

Communications power U_L

Supply voltage	7.5 V DC (via voltage jumper)
Current draw	typ. 40 mA max. 30 mA

Supply of analog modules U_{ANA}

Supply voltage	24 V DC (via voltage jumper)
Supply voltage range	19.2 V DC ... 30 V DC (including all tolerances, including ripple)
Current draw	typ. 50 mA max. 65 mA

Power consumption

Power consumption	typ. 1.425 W (total) max. 1.86 W (total)
-------------------	---

Analog output

Number of outputs	1
Connection technology	2-wire
Note regarding the connection technology	shielded
Current output signal	0 mA ... 20 mA, 4 mA ... 20 mA
Voltage output signal	0 V ... 10 V
D/A resolution	16 bit
Representation of output values	16-bit straight binary
Process data update	< 1 ms
Load/output load current output	< 500 Ω
Load/output load voltage output	> 2 kΩ
Precision	typ. 0.15 % (of output range final value, current range 0 mA ... 20 mA) typ. 0.25 % (of output range final value, current range 4 mA ... 20 mA) typ. 0.3 % (of output range final value, voltage range 0 V ... 10 V)
Slew rate	< 0.15 ms (>99 % of final value, voltage output with R _L = 10 kΩ)
Transient protection of outputs	yes

Programming data (INTERBUS, local bus)

ID code (hex)	7D
ID code (dec.)	125
Length code (hex)	01
Length code (dec.)	01
Process data channel	16 Bit
Input address area	0 Byte
Output address area	2 Byte
Parameter channel (PCP)	0 Byte
Register length (bus)	16 Bit

Configuration and parameter data in a PROFIBUS system

Required parameter data	4 Byte
Need for configuration data	4 Byte

Error messages to the higher level control or computer system

Failure of or insufficient communications power U_L	I/O error message sent to the bus coupler
---	---

Electrical isolation/isolation of the voltage areas

Test section	Test voltage
7.5 V supply (bus logic), 24 V supply U_{ANA} / I/O	500 V AC, 50 Hz, 1 min.
7.5 V supply (bus logic), 24 V supply U_{ANA} /functional earth ground	500 V AC, 50 Hz, 1 min.
I/O / functional earth ground	500 V AC, 50 Hz, 1 min.

Approvals

For the latest approvals, please visit phoenixcontact.net/products.

5 Additional technical data

5.1 Mechanical requirements

The following data deviates from the specifications in the user manual IL SYS INST UM.

Mechanical tests

Shock in acc. with EN 60068-2-27/IEC 60068-2-27

15g load for 11 ms, half sinusoidal wave, three shocks per space direction and orientation

25g load for 6 ms, half sinusoidal wave, three shocks per space direction and orientation

5.2 Derating

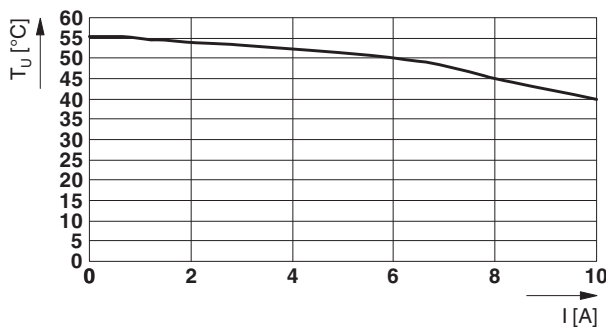

Figure 1 Derating: permissible ambient temperature depending on the current in the potential jumpers U_M and U_S (total current)

5.3 Tolerance specifications



All percentage tolerance values refer to the relevant positive output range final value. Unless stated otherwise, nominal operation (nominal voltage, preferred mounting position) is used as the basis. The tolerance values refer to the operating temperature range specified in the tables. The operable range outside this temperature range is not taken into consideration. Please also take into consideration the tolerances influenced by electromagnetic interference.

The maximum tolerance values represent the worst-case measurement inaccuracy. They contain the theoretical maximum possible tolerances in the output range sections as well as the theoretical maximum possible tolerances of the calibration and test equipment.

5.3.1 Tolerance and temperature response of the voltage output

The tolerance values refer to the output range final value of 10 V.

	Typical	Maximum
Tolerance at 23°C		
Total offset voltage	±0.03%	±0.05 %
Tolerance through gain	±0.10%	±0.15 %
Differential non-linearity	±0.0012 %	±0.003 %
Total tolerance	±0.15 %	±0.25%
Temperature and drift response ($T_A = -25^\circ\text{C} \dots +55^\circ\text{C}$)		
Offset voltage drift T_{KVO}	±10 ppm/K	±65 ppm/K
Gain drift T_{KG}	±30 ppm/K	±35 ppm/K
Total voltage drift $T_{Ktot} = T_{KVO} + T_{KG}$	±40 ppm/K	±100 ppm/K
Total tolerance (tolerance through offset, gain, linearity, and drift)	±0.30%	±0.60 %

5.3.2 Tolerance and temperature response of the current output (0 mA ... +20 mA)

The tolerance values refer to the output range final value of 20 mA.

	Typical	Maximum
Tolerance at 23°C		
Offset current	±0.05 %	±0.15 %
Tolerance through gain	±0.09 %	±0.25%
Differential non-linearity	±0.0012 %	±0.003 %
Total tolerance	±0.15 %	±0.25%
Temperature and drift response ($T_A = -25^\circ\text{C} \dots +55^\circ\text{C}$)		
Offset current drift T_{KIO}	±25 ppm/K	±65 ppm/K
Gain drift T_{KG}	±10 ppm/K	±35 ppm/K
Total current drift $T_{Ktot} = T_{KIO} + T_{KG}$	±35 ppm/K	±100 ppm/K

5.3.3 Tolerance and temperature response of the current output (+4 mA ... +20 mA)

The tolerance values refer to the output range final value of 20 mA.

	Typical	Maximum
Tolerance at 23°C		
Offset current	±0.15 %	±0.45 %
Tolerance through gain	±0.25%	±0.45 %
Differential non-linearity	±0.003 %	±0.005 %
Total tolerance	±0.25%	±0.46 %
Temperature and drift response ($T_A = -25^\circ\text{C} \dots +55^\circ\text{C}$)		
Offset current drift T_{KIO}	±28 ppm/K	±70 ppm/K
Gain drift T_{KG}	±15 ppm/K	±40 ppm/K
Total current drift $T_{Ktot} = T_{KIO} + T_{KG}$	±43 ppm/K	±110 ppm/K

5.3.4 Additional tolerances influenced by electromagnetic interference

Type of electromagnetic interference	Criterion	Typical deviation in % referencing the output range final value
Electromagnetic fields; field strength 10 V/m according to EN 61000-4-3/IEC 61000-4-3	A	< 1 %
Conducted interference, Class 3 (10 V test voltage) according to EN 61000-4-6/IEC 61000-4-6	A	< 6 %
Fast transients (burst) according to EN 61000-4-4/IEC 61000-4-4	B	< 1 %

6 Internal circuit diagram

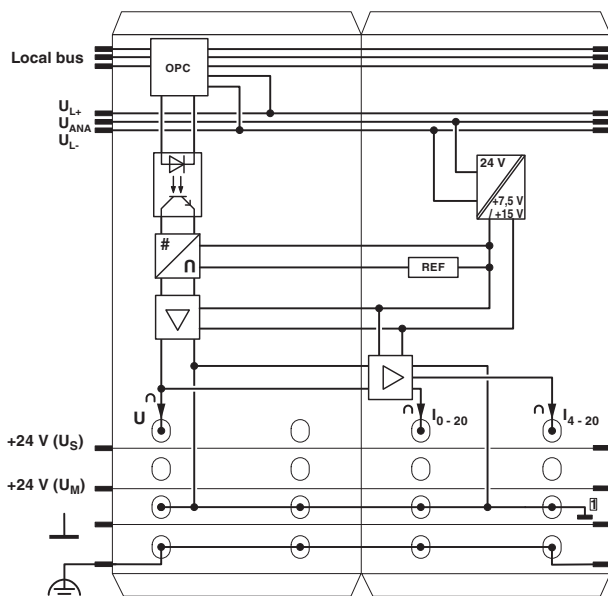









Figure 2 Internal wiring of the terminal points

Key:

-  Protocol chip
 -  Optocoupler
 -  Power supply unit with electrical isolation
 -  Digital/analog converter
 -  Output amplifier
 -  Reference voltage source
 -  Analog ground, electrically isolated from ground of the potential jumper
-  Explanation for other used symbols has been provided in the IL SYS INST UM E user manual.

7 Electrical isolation

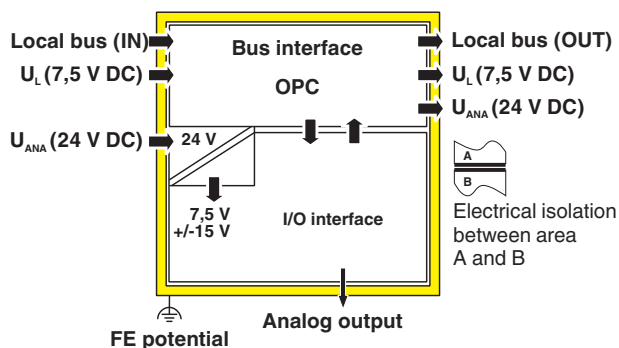

Figure 3 Electrical isolation of the individual function areas

8 Notes on using the terminal block in potentially explosive areas



WARNING: Explosion hazard
Please make sure that the following notes and instructions are observed.

Approval according to ATEX Directive 2014/34/EU

II 3 G Ex nA IIC T4 Gc X

Installation notes

T_{amb} = -25 °C ... +55 °C

The category 3 device is designed for installation in zone 2 potentially explosive areas.

The device meets the requirements of EN 60079-0:2012 + A11:2013 and EN 60079-15:2010.

- Observe the specified conditions for use in potentially explosive areas! Also observe the requirements of EN 60079-14.
- Install the device in a suitable approved housing (with at least IP54 protection) that meets the requirements of EN 60079-15.
- Only assemble, disassemble as well as connect and disconnect cables when the power is disconnected.
- Only devices that are designed for operation in Ex Zone 2 and the conditions at the installation location may be connected to the circuits in Zone 2.
- For safe operation, lockable plug connections must have a functional interlock (e. g. locking clip, screw connection etc.). Insert the interlock. Repair any damaged connectors immediately.
- Only connect one cable per terminal point.
- Use transient protection so that short-term surge voltages do not exceed 119 V.
- The air pressure during operation must not exceed 106 kPa.
- Perform a dielectric test after installing the device in the housing.
- For all supply and signal lines connected to the station, make sure that there is a connection to ground potential.
- Make sure that the maximum permissible current of 4 A flowing through potential jumpers U_M and U_S (total current) is not exceeded.
- When using the device in potentially explosive areas, observe the specifications in the application note AH DE IL EX ZONE 2 (German) / AH EN IL EX ZONE 2 (English).

9 Terminal point assignment

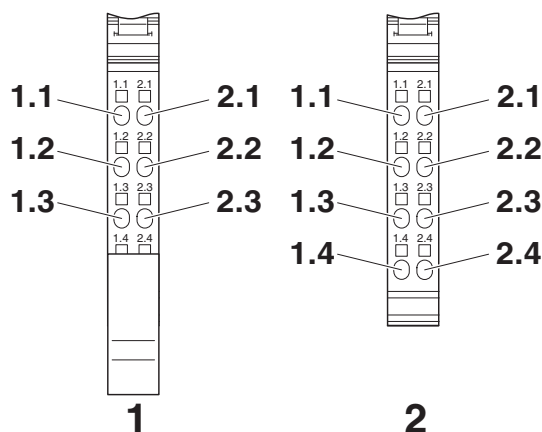

Figure 4 Terminal point assignment

Terminal point	Signal	Meaning
Connector 1		
1.1	U	Voltage output 0 V to 10 V
2.1	-	Not used
Connector 2		
1.1	I	Current output 0 mA to 20 mA
2.1	I	Current output 4 mA to 20 mA
Connector 1 and 2		
1.2, 2.2	-	Not used
1.3 / 2.3	AGND	Analog ground
1.4, 2.4	Shield	Shield connection



NOTE: Terminal overheating

- Only assign one output to the terminal.
- Connect the actuator via the shield plug.

10 Connection examples



Use a connector with shield connection when installing the actuator.

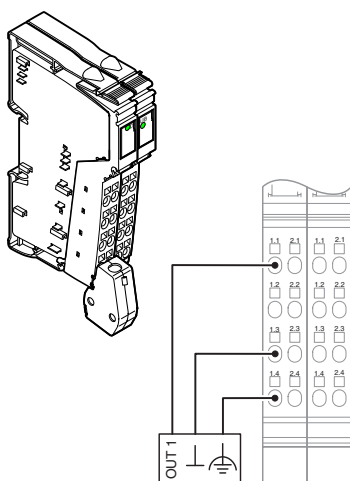

Figure 5 Actuator at the voltage output

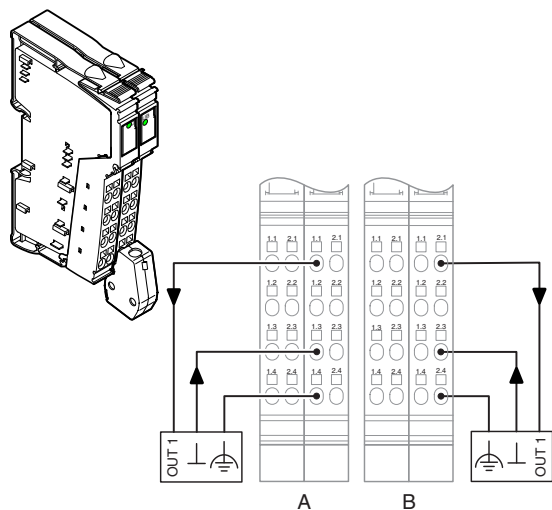

Figure 6 Actuator at the current output

- A Current output 0 mA ... 20 mA
- B Current output 4 mA ... 20 mA

11 Connection notes

Always connect the analog actuators using shielded twisted-pair cables.

At the terminal, connect one end of the shielding to PE. At the module, fold the outer cable sheath back and connect the shield to the terminal via the shield connection clip. The clamp connects the shield directly to FE on the module side.

When using cables longer than 10 m in environments prone to interference, we recommend connecting the shield on the actuator to the FE potential additionally via an RC element. The capacitor C should typically have values of 1 nF to 15 nF. The resistor R should have a resistance of at least 10 M Ω .

Use an I/O connector with shield connection when installing the actuator. On the base side that is not used to connect an actuator, you may use one of the connectors listed in the ordering data.

12 Installation instructions

High current flowing through potential jumpers U_M and U_S leads to a temperature rise in the potential jumpers and inside the terminal. To keep the current flowing through the potential jumpers of the analog terminals as low as possible, always place the analog terminals after all the other terminals at the end of the main circuit (for the sequence of the Inline terminals: see also IL SYS INST UM E user manual).

13 Local diagnostic and status indicators

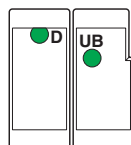

Figure 7 Local diagnostic and status indicators

Designation	Color	Meaning
D	green	Diagnostics (bus and logic voltage)
UB	green	I/O voltage is present (current level)



For detailed information on diagnostics, please refer to the IL SYS INST UM E user manual.

Function identification

Yellow

14 Process data

The terminal uses one process data input word and one process data output word.

The process data output word transmits the output value in each cycle.

All output values are represented in 16 bits.

(Word.bit) view	Word Bit	Word 0		
		15	...	0
Connector 1	Terminal point (signal)	1.1: voltage output		
	Terminal point (GND)	1.3 / 2.3		
	Terminal point (shield/FE)	1.4, 2.4		
Connector 2	Terminal point (signal)	1.1: current output 0 mA ... 20 mA		
		2.1: current output 4 mA ... 20 mA		
	Terminal point (GND)	1.3 / 2.3		
	Terminal point (shield/FE)	1.4, 2.4		



For the assignment of the illustrated (word.bit) view to your INTERBUS control or computer system, please refer to the DB GB IBS SYS ADDRESS data sheet.

15 Significant values

Abbreviations used in the following tables

QS	Quantization step(s)
ORF	Output range final value
Bit 15	Most significant bit (MSB)
Bit 0	Least significant bit (LSB)

Process data output word for the voltage output 0 V ... 10 V (example)

Voltage output 0 V ... 10 V	Analog value [V]	Process data output word		
		hex	Binary (two's complement)	
			15 ... 8	7 ... 0
10 V - 1 QS	9.99985	FFFF	11111111	11111111
10 V - 2 QS	9.99969	FFFE	11111111	11111110
1/2 ORF	5.0000	8000	10000000	00000000
1 QS	0.153 mV	0001	00000000	00000001
Zero	0.0000	0000	00000000	00000000

Process data output word for the current output 0 mA ... 20 mA (example)

Current output 0 mA ... 20 mA	Analog value [mA]	Process data output word		
		hex	Binary (two's complement)	
			15 ... 8	7 ... 0
20 mA - 1 QS	19.9997	FFFF	11111111	11111111
20 mA - 2 QS	19.9994	FFFE	11111111	11111110
1/2 ORF	10.000	8000	10000000	00000000
1 QS	0.305 μ A	0001	00000000	00000001
Zero	0.0000	0000	00000000	00000000

Process data output word for the current output 4 mA ... 20 mA (example)

Current output 4 mA ... 20 mA	Analog value [mA]	Process data output word		
		hex	Binary (two's complement)	
			15 ... 8	7 ... 0
20 mA - 1 QS	19.99998	FFFF	11111111	11111111
20 mA - 2 QS	19.99995	FFFE	11111111	11111110
1/2 ORF	12.0000	8000	10000000	00000000
4 mA + 1 QS	4.000244	0001	00000000	00000001
Output range start	4.0000	0000	00000000	00000000

16 Output behavior



When configuring your system, take into account output behavior in the event of an error

Output behavior depending on the state of the power supply

Switching operation/state of the supply voltage	Marginal condition	OUT process data word [hex]	Behavior/status of the analog output		
			0 V ... 10 V	0 mA ... 20 mA	4 mA ... 20 mA
U_{ANA} from 0 V to 24 V	$U_L = 0$ V	xxxx	0 V	0 mA	4 mA
U_{ANA} from 24 V to 0 V	$U_L = 7.5$ V	xxxx	0 V	0 mA	0 mA
Bus in stop state	$U_{ANA} = 0$ V	xxxx	0 V	0 mA	0 mA
Bus in stop state	$U_{ANA} = 24$ V	xxxx	Hold last value		

U_{ANA} Analog supply voltage of the terminal

U_L Supply voltage for module electronics (communications power)

xxxx Any value in the range from 0000_{hex} ... $FFFF_{hex}$



The behavior of the output depends on the output used.



SCATTERGOOD & JOHNSON LTD

ELECTRICAL ENGINEERING & FLUID CONTROL DISTRIBUTORS

Est.1899

At Scattergood & Johnson Ltd, we pride ourselves on being a technical distributor to specialist industries.

Working with a range of quality product suppliers across a number of specialist markets, we are not your average 'box shifter' - we are your technical and supply chain partner.

We fully support every product we sell - for free! Our internal team and external sales engineers can answer any product or application question, no matter the complexity.

Backing up this technical ability is a range of 50,000+ products available from stock for nationwide next day delivery (same day if required!), or you can collect what you need from any of our trade counters around the UK.

Select your specialist interest below to learn more about how we can help.

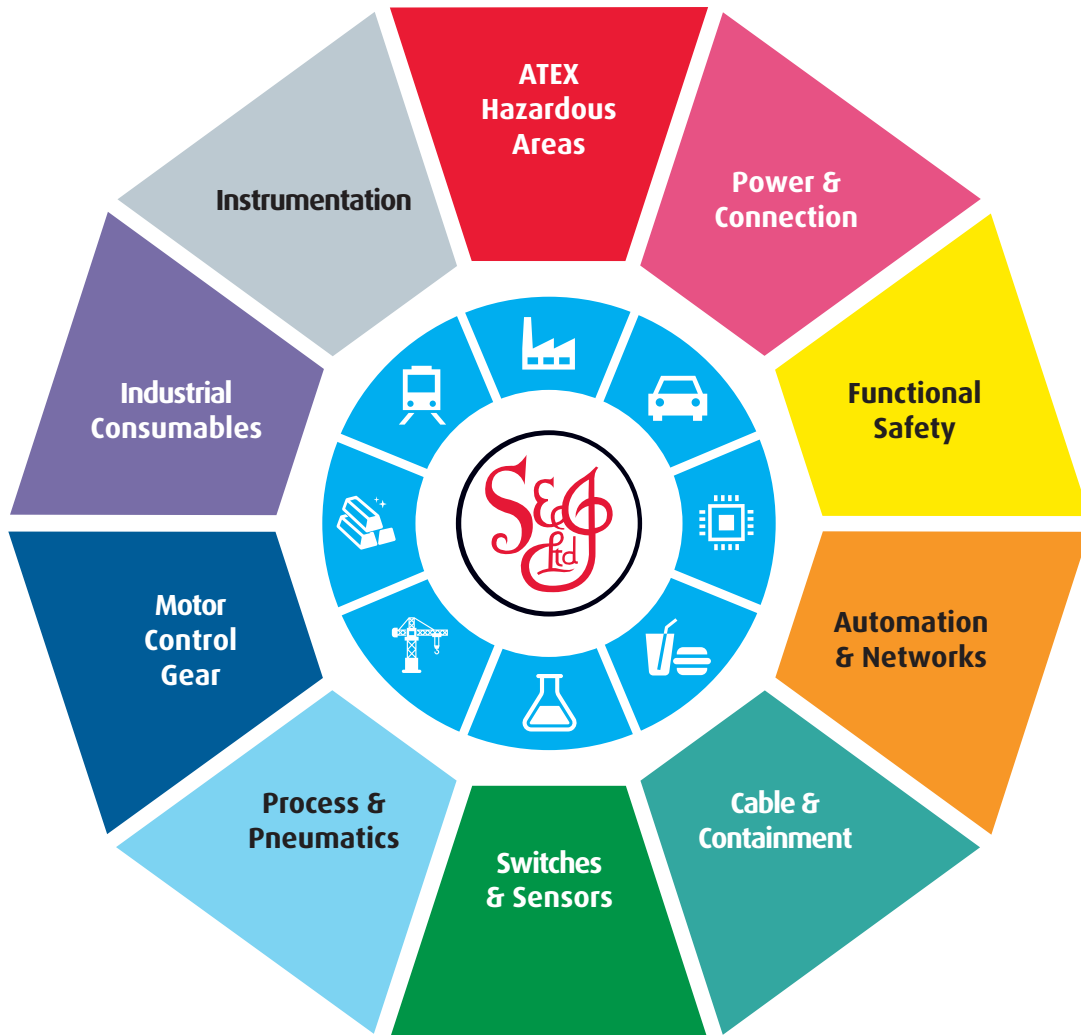

Online, In Branch and On the Road - Scattergood & Johnson Ltd, there when you need us.

www.scatts.co.uk