

IB IL TEMP 2 RTD-PAC

**Inline, Temperature measurement terminal,
analog RTD inputs: 2**

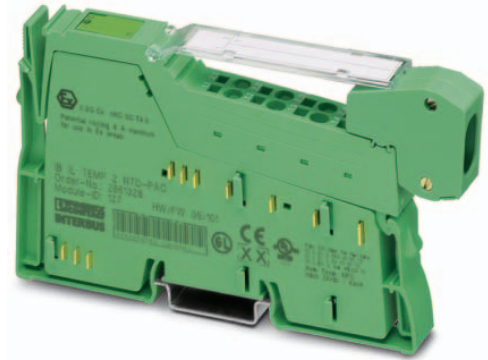

Data sheet
5755_en_07

© PHOENIX CONTACT 2018-04-05

1 Description

The terminal is designed for use within an Inline station. It is used to acquire signals from resistive temperature sensors.

The terminal supports all common platinum and nickel sensors according to DIN EN 60751 and SAMA. Cu10, Cu50, and Cu53 sensors as well as KTY81 and KTY84 sensors are also supported.

The measuring temperature is represented by 16-bit values in two process data words (one word per channel).

Features

- Two inputs for resistive temperature sensors
- Pt, Ni, Cu, KTY sensor types according to DIN and SAMA
- Connection of sensors in 2, 3, and 4-wire technology
- The channels are parameterized independently of one another via the bus system
- Measured values can be represented in three different formats
- Measured value acquisition with 16-bit resolution



WARNING: Explosion hazard when used in potentially explosive areas

When using the terminal in potentially explosive areas, observe the corresponding notes.



This data sheet is only valid in association with the IL SYS INST UM E user manual.



Make sure you always use the latest documentation.

It can be downloaded from the product at [phoenixcontact.net/products](https://www.phoenixcontact.net/products).

2	Table of contents	
1	Description	1
2	Table of contents	2
3	Ordering data	3
4	Technical data	3
5	Tolerance and temperature response	6
	5.1 Typical measuring tolerances at 25 °C	6
	5.2 Maximum measuring tolerances at 25 °C	7
	5.3 Temperature response at -25 °C ... +55 °C	7
	5.4 Additional tolerances influenced by electromagnetic interference	7
6	Internal circuit diagram	8
7	Electrical isolation	8
8	Notes on using the terminal block in potentially explosive areas	9
9	Terminal point assignment	10
	9.1 2- and 3-wire termination	10
	9.2 4-wire termination at channel 1 and 2-wire termination at channel 2	10
10	Installation instructions	10
11	Connection notes	10
12	Connection examples	11
	12.1 Connection of passive sensors	11
	12.2 Connection of a potentiometer	11
13	Local diagnostic and status indicators	13
14	Process data	13
	14.1 OUT process data	13
	14.2 IN process data	16
	14.3 Assignment of the terminal points to IN process data	16
15	Formats for representing measured values	17
	15.1 IB IL format	17
	15.2 IB ST format	19
	15.3 IB RT format	20
16	Measuring ranges	21
	16.1 Measuring ranges depending on the resolution (IB IL format)	21
	16.2 Input measuring ranges	21
17	Measuring error	22
	17.1 Systematic measuring errors during temperature measurement using resistance thermometers	22
	17.2 Systematic errors during temperature measurement using 2-wire technology	23

3 Ordering data

Description	Type	Order No.	Pcs./Pkt.
Inline, Temperature measurement terminal, Analog RTD inputs:2, connection method: 2, 3, 4-wire, transmission speed in the local bus: 500 kbps, degree of protection: IP20, including Inline connector and labeling field	IB IL TEMP 2 RTD-PAC	2861328	1
Accessories	Type	Order No.	Pcs./Pkt.
Inline shield connector (Connector/Adapter)	IB IL SCN 6-SHIELD-TWIN	2740245	5
Labeling field, width: 12.2 mm (Marking)	IB IL FIELD 2	2727501	10
Insert strip, Sheet, white, unlabeled, can be labeled with: Office printing systems: Laser printer, mounting type: insert, lettering field size: 62 x 10 mm (Marking)	ESL 62X10	0809492	1
Documentation	Type	Order No.	Pcs./Pkt.
User manual, English, Automation terminals of the Inline product range	IL SYS INST UM E	-	-
Data sheet, English, INTERBUS addressing	DB GB IBS SYS ADDRESS	-	-
Application note, English, Inline terminals for use in zone 2 potentially explosive areas	AH EN IL EX ZONE 2	-	-

4 Technical data

Dimensions (nominal sizes in mm)

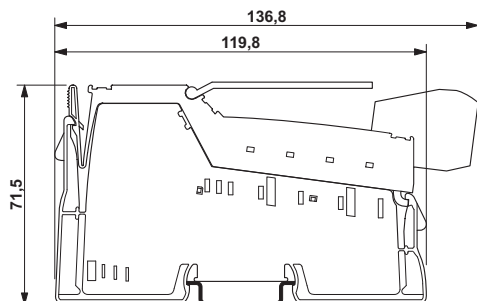

Width	12.2 mm
Height	136.8 mm
Depth	71.5 mm

General data	
Color	green
Weight	67 g (with connector)
Operating mode	Process data operation with 2 words
Ambient temperature (operation)	-25 °C ... 55 °C
Ambient temperature (storage/transport)	-25 °C ... 85 °C
Permissible humidity (operation)	10 % ... 95 % (non-condensing)
Permissible humidity (storage/transport)	10 % ... 95 % (non-condensing)
Air pressure (operation)	70 kPa ... 106 kPa (up to 3000 m above sea level) 80 kPa ... 106 kPa (up to 3000 m above sea level, in ATEX Zone 2)
Air pressure (storage/transport)	70 kPa ... 106 kPa (up to 3000 m above sea level)
Degree of protection	IP20
Protection class	III, IEC 61140, EN 61140, VDE 0140-1
Connection data: Inline connector	
Connection method	Spring-cage connection
Conductor cross section solid / stranded	0.08 mm ² ... 1.5 mm ² / 0.08 mm ² ... 1.5 mm ²
Conductor cross section [AWG]	28 ... 16
Stripping length	8 mm
Connection data for UL approvals: Inline connector	
Connection method	Spring-cage connection
Conductor cross section solid / stranded	0.2 mm ² ... 1.5 mm ² / 0.2 mm ² ... 1.5 mm ²
Conductor cross section [AWG]	24 ... 16
Stripping length	8 mm
Interface: Inline local bus	
Number	2
Connection method	Inline data jumper
Transmission speed	500 kbps
Communications power U_L	
Supply voltage	7.5 V DC (via voltage jumper)
Current draw	typ. 43 mA max. 60 mA
Supply of analog modules U_{ANA}	
Supply voltage	24 V DC (via voltage jumper)
Supply voltage range	19.2 V DC ... 30 V DC (including all tolerances, including ripple)
Current draw	typ. 11 mA max. 18 mA
Power consumption	
Power consumption	typ. 587 mW max. 882 mW

Analog RTD inputs

Number of inputs	2
Connection method	Spring-cage connection
Connection technology	2, 3, 4-wire, shielded
Sensor types (RTD) that can be used	Pt, Ni, KTY, Cu sensors, linear resistors
Linear resistance measuring range	0 Ω ... 400 Ω , 0 Ω ... 4 k Ω
Resolution A/D	16 bit (15 bit + sign bit)
A/D conversion time	typ. 120 μ s (per channel)
Measuring principle	Successive approximation
Measured value representation	16 bit two's complement
Process data update	32 ms (both channels with 3-wire technology) 20 ms (one channel with 2-wire technology and one channel with 4-wire technology) 20 ms (Both channels use 2-wire technology)
Absolute accuracy	typ. \pm 0.26 $^{\circ}$ C (Pt 100 with 3-wire connection)

Programming data (INTERBUS, local bus)

ID code (hex)	7F
ID code (dec.)	127
Length code (hex)	02
Length code (dec.)	02
Process data channel	32 Bit
Input address area	4 Byte
Output address area	4 Byte
Parameter channel (PCP)	0 Byte
Register length (bus)	32 Bit



For the programming data/configuration data of other bus systems, please refer to the corresponding electronic device data sheet (e.g., GSD, EDS).

Configuration and parameter data in a PROFIBUS system

Required parameter data	6 Byte
Required configuration data	4 Byte

Error messages to the higher level control or computer system

Failure of the internal I/O supply	I/O error message sent to the bus coupler
Failure of or insufficient communications power U_L	I/O error message sent to the bus coupler
Peripheral fault	Error message in the process data
User error	Error message in the process data

Electrical isolation/isolation of the voltage areas

Test section	Test voltage
7.5 V supply (bus logics)/24 V analog supply (analog I/O)	500 V AC, 50 Hz, 1 min.
7.5 V supply (bus logics) / functional earth ground	500 V AC, 50 Hz, 1 min.
24 V analog supply (analog I/O) / functional earth ground	500 V AC, 50 Hz, 1 min.

Approvals

For the latest approvals, please visit phoenixcontact.net/products.

5 Tolerance and temperature response

The **percentage tolerances** refer to the positive measuring range final value.

The **maximum tolerances** contain the theoretical maximum possible tolerances.

The data is valid for nominal operation (preferred mounting position, $U_{ANA} = 24\text{ V}$).

Please also observe the values for temperature drift and the tolerances under influences of electromagnetic interferences.

- α Average sensitivity for the calculation of tolerance values
- x Additional error when the connection is made using 2-wire technology (see "Systematic errors during temperature measurement using 2-wire technology").

5.1 Typical measuring tolerances at 25 °C

Sensor type	α at 100 °C	2-wire technology		3-wire technology		4-wire technology	
		Relative [%]	Absolute	Relative [%]	Absolute	Relative [%]	Absolute
Temperature sensors							
Pt 100	0.385 Ω/K	±0.03 % + x	±0.26 K + x	±0.03%	±0.26 K	±0.02%	±0.20 K
Pt 1000	3.85 Ω/K	±0.04 % + x	±0.31 K + x	±0.04 %	±0.31 K	±0.03%	±0.26 K
Ni 100	0.617 Ω/K	±0.09 % + x	±0.16 K + x	±0.09 %	±0.16 K	±0.07%	±0.12 K
Ni 1000	6.17 Ω/K	±0.11 % + x	±0.20 K + x	±0.11 %	±0.20 K	±0.09 %	±0.16 K
Cu 50	0.213 Ω/K	±0.24 % + x	±0.47 K + x	±0.24%	±0.47 K	±0.18 %	±0.35 K
Ni 1000 (L&G)	5.6 Ω/K	±0.13 % + x	±0.21 K + x	±0.13%	±0.21 K	±0.11 %	±0.18 K
Ni 500 (Viessmann)	2.8 Ω/K	±0.17 % + x	±0.43 K + x	±0.17 %	±0.43 K	±0.14 %	±0.36 K
KTY 81-110	10.7 Ω/K	±0.07 % + x	±0.11 K + x	±0.07%	±0.11 K	±0.06%	±0.09 K
KTY 84	6.2 Ω/K	±0.06 % + x	±0.19 K + x	±0.06%	±0.19 K	±0.05 %	±0.16 K
Linear resistance							
0 Ω ... 400 Ω		±0.025 + x	±100 mΩ + x	±0.025 %	±100 mΩ	±0.019 %	±75 mΩ
0 Ω ... 4000 Ω		±0.03 % + x	±1,2 Ω + x	±0.03%	±1.2 Ω	±0.025 %	±1.0 Ω

5.2 Maximum measuring tolerances at 25 °C

Sensor type	α at 100 °C	2-wire technology		3-wire technology		4-wire technology	
		Relative [%]	Absolute	Relative [%]	Absolute	Relative [%]	Absolute
Temperature sensors							
Pt 100	0.385 Ω/K	±0.12 % + x	±1.04 K + x	±0.12 %	±1.04 K	±0.10%	±0.83 K
Pt 1000	3.85 Ω/K	±0.15 % + x	±1.3 K + x	±0.15 %	±1.3 K	±0.12 %	±1.04 K
Ni 100	0.617 Ω/K	±0.36 % + x	±0.65 K + x	±0.36 %	±0.65 K	±0.29%	±0.52 K
Ni 1000	6.17 Ω/K	±0.45 % + x	±0.81 K + x	±0.45 %	±0.81 K	±0.36 %	±0.65 K
Cu 50	0.213 Ω/K	±0.47 % + x	±0.94 K + x	±0.47%	±0.94 K	±0.38 %	±0.75 K
Ni 1000 (L&G)	5.6 Ω/K	±0.56 % + x	±0.89 K + x	±0.56 %	±0.89 K	±0.44 %	±0.71 K
Ni 500 (Viessmann)	2.8 Ω/K	±0.72 % + x	±1.79 K + x	±0.72 %	±1.79 K	±0.57 %	±1.43 K
KTY 81-110	10.7 Ω/K	±0.31 % + x	±0.47 K + x	±0.31%	±0.47 K	±0.25%	±0.37 K
KTY 84	6.2 Ω/K	±0.27 % + x	±0.81 K + x	±0.27%	±0.81 K	±0.22 %	±0.65 K
Linear resistance							
0 Ω ... 400 Ω		±0.10 % + x	±400 mΩ + x	±0.10%	±400 mΩ	±0.08%	±320 mΩ
0 Ω ... 4000 Ω		±0.13 % + x	±5 Ω + x	±0.13%	±5 Ω	±0.10%	±4 Ω

5.3 Temperature response at -25 °C ... +55 °C

Connection method	Typical	Maximum
2-, 3-, 4-wire technology	±12 ppm/K	±45 ppm/K

5.4 Additional tolerances influenced by electromagnetic interference

Type of electromagnetic interference	Standard	Level	Additional tolerances of measuring range final value	Criterion
Electromagnetic fields	EN 61000-4-3/ IEC 61000-4-3	10 V/m	< ±1.51 %	A
Fast transients (burst)	EN 61000-4-4/ IEC 61000-4-4	Class 3	< ±0.24 %	A
Conducted interference	EN 61000-4-6/ IEC 61000-4-6	Class 3 (test voltage 10 V)	< ±0.92 %	A

6 Internal circuit diagram

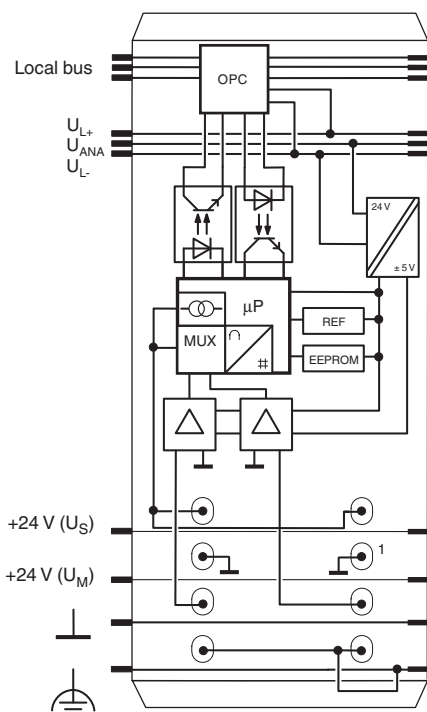









Figure 1 Internal wiring of the terminal points

Key:

	Protocol chip
	Optocoupler
	Power supply unit with electrical isolation
	Microprocessor with multiplexer and analog-to-digital converter
	Reference voltage source
	Electrically erasable programmable read-only memory
	Input amplifier



Please refer to the IL SYS INST UM E user manual for an explanation of other symbols used.

7 Electrical isolation

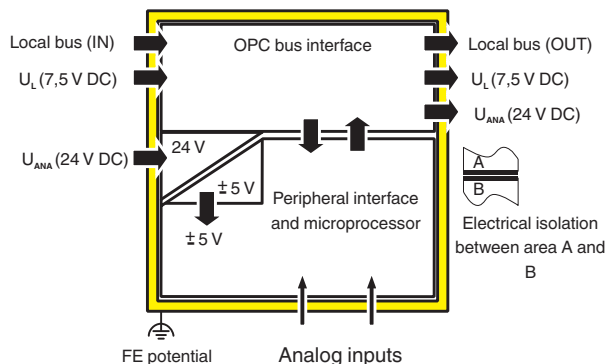

Figure 2 Electrical isolation of the individual function areas

8 Notes on using the terminal block in potentially explosive areas

**WARNING: Explosion hazard**

Please make sure that the following notes and instructions are observed.

Approval according to ATEX Directive 2014/34/EU

Ⓜ II 3 G Ex nA IIC T4 Gc X

Installation notes

$T_{amb} = -25\text{ °C} \dots +55\text{ °C}$

The category 3 device is designed for installation in zone 2 potentially explosive areas.

The device meets the requirements of EN 60079–0 and EN 60079–15.

- Observe the specified conditions for use in potentially explosive areas! Also observe the requirements of EN 60079-14.
- Install the device in a suitable approved housing (with at least IP54 protection) that meets the requirements of EN 60079-15.
- Only assemble, disassemble as well as connect and disconnect cables when the power is disconnected.
- Only devices that are designed for operation in Ex Zone 2 and the conditions at the installation location may be connected to the circuits in Zone 2.
- For safe operation, lockable plug connections must have a functional interlock (e. g. locking clip, screw connection etc.). Insert the interlock. Repair any damaged connectors immediately.
- Only connect one cable per terminal point.
- Use transient protection so that short-term surge voltages do not exceed 119 V.
- The air pressure during operation must not exceed 106 kPa.
- Perform a dielectric test after installing the device in the housing.
- For all supply and signal lines connected to the station, make sure that there is a connection to ground potential.
- Make sure that the maximum permissible current of 4 A flowing through potential jumpers U_M and U_S (total current) is not exceeded.
- When using the device in potentially explosive areas, observe the specifications in the application note AH DE IL EX ZONE 2 (German) / AH EN IL EX ZONE 2 (English).

9 Terminal point assignment

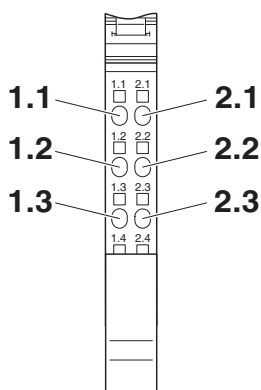

Figure 3 Terminal point assignment

9.1 2- and 3-wire termination

Terminal point	Signal	Meaning	
1.1	I1+	Constant current supply	RTD sensor 1
1.2	I1-		
1.3	U1-		
2.1	I2+	Constant current supply	RTD sensor 2
2.2	I2-		
2.3	U2-		
1.4, 2.4	Shield	Shield connection	Channel 1 and 2

9.2 4-wire termination at channel 1 and 2-wire termination at channel 2

Terminal point	Signal	Meaning	
1.1	I1+	Constant current supply	RTD sensor 1
1.2	I1-		
1.3	U1-		
2.1	U1+	Measuring input	
2.2	I2+	Constant current supply	RTD sensor 2
2.3	I2-		
1.4, 2.4	Shield	Shield connection	Channel 1 and 2



Only connect a sensor in 4-wire technology to channel 1.
In this case, only connect a sensor in 2-wire technology to channel 2.



WARNING: danger of electric shock

No isolating voltage for safe isolation is specified between the analog inputs and the local bus.

- Please take this into consideration during configuration.
- If required, provide signals with safe isolation (e.g., for thermistor detection).

10 Installation instructions

High current flowing through potential jumpers U_M and U_S leads to a temperature rise in the potential jumpers and inside the terminal. To keep the current flowing through the potential jumpers of the analog terminals as low as possible, always place the analog terminals after all the other terminals at the end of the main circuit (for the sequence of the Inline terminals: see also IL SYS INST UM E user manual).

11 Connection notes

Connecting the resistance temperature detectors



Only connect a sensor in 4-wire technology to channel 1.
In this case, only connect a sensor in 2-wire technology to channel 2.

Connecting the shield

Always connect the analog sensors using shielded, twisted pair cables.

Connect the shielding to the terminal using the shield connection clamp. The clamp connects the shield directly to FE on the terminal side. Additional wiring is not required.

Insulate the shielding at the sensor.

Connecting a sensor

Always connect the temperature shunts using shielded twisted pair cables.

12 Connection examples



When connecting the shield at the terminal, you must insulate the shield on the sensor side.

Use a connector with overall shielding braid when installing the sensors. The figures below illustrate the connection (without overall shielding braid).

12.1 Connection of passive sensors

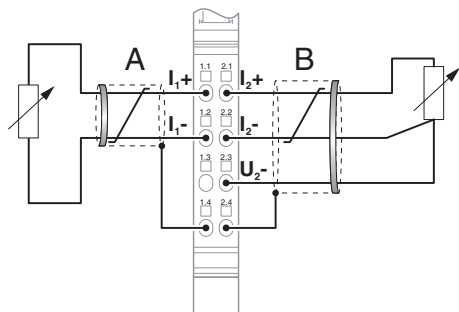

Figure 4 Connection of passive sensors in 2-wire and 3-wire technology with shield connection

- A Channel 1 2-wire technology
- B Channel 2 3-wire technology

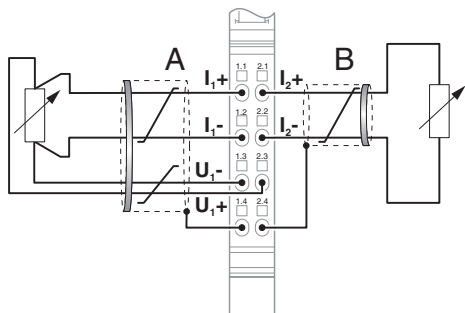

Figure 5 Connection of passive sensors in 4-wire and 2-wire technology with shield connection

- A Channel 1 4-wire technology
- B Channel 2 2-wire technology

12.2 Connection of a potentiometer

The connection and direct percent evaluation of a 2 kΩ potentiometer.

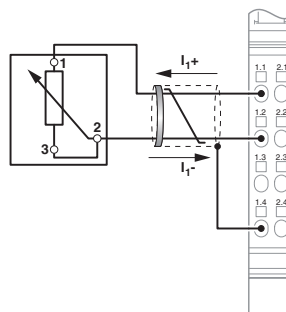

Figure 6 Connection of a potentiometer in 2-wire technology with shield connection

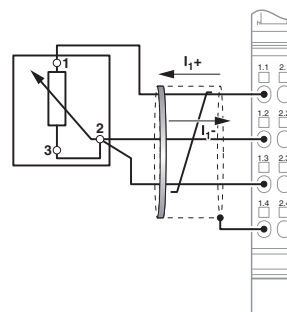

Figure 7 Connection of a potentiometer in 3-wire technology with shield connection

IB IL TEMP 2 RTD-PAC

Parameter configuration using the output process data when connecting a potentiometer

Bit	15	14	13	12	11	10	9	8	7	6	5	4	3	2	1	0
Meaning	Parameteri- zation	Reserved	Connection		R0				Resolution		Format		Sensor type			
2-wire technology																
Assignment	1	0	0	1	1	1	1	0	0	1	0	0	1	1	0	1
Setting	Parameteri- zation	0	2-wire		2 k Ω				0.1 %		IB IL		Potentiometer (D _{hex} /13 _{dec})			
3-wire technology																
Assignment	1	0	0	0	1	1	1	0	0	1	0	0	1	1	0	1
Setting	Parameteri- zation	0	3-wire		2 k Ω				0.1 %		IB IL		Potentiometer (D _{hex} /13 _{dec})			

Operation and evaluation of input process data

No.	Position of the potentiometer slider tap	Potentiometer resistance at tap	Value in input process data	Percent value
1	Open	2000 Ω	1000	100 %
2	Middle	1000 Ω	500	50 %
3	Almost closed	22 Ω	11	1.1 %
4	Closed	0 Ω	0	0 %

13 Local diagnostic and status indicators

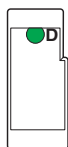

Figure 8 Local diagnostic and status indicators

Designation	Color	Meaning
D	Green	Diagnostics (bus and logic voltage)



For detailed information on diagnostics, please refer to the IL SYS INST UM E user manual.

Function identification

Green

14 Process data

The terminal uses two words of IN process data and two words of OUT process data.

Each channel is mapped to a word.

The analog values are transmitted via the input process data.

The terminal can be parameterized via the OUT process data.

14.1 OUT process data

You can parameterize each channel independently of the other channels. Parameterize the first channel via the first output word (OUT0), and the second channel via the second output word (OUT1).

The following parameterization options are available:

- Type of sensor connection
- Value of the reference resistor R_0
- Selecting the formats for representing measured values
- Sensor type selection



The two channels are dependent on each other for the connection method.

The 4-wire termination method is only available for channel 1.

Only connect a sensor in 4-wire technology to channel 1.

In this case, only connect a sensor in 2-wire technology to channel 2.

The parameterization is not saved. Transmit the parameterization in each bus cycle.

After applying voltage (power up) to the Inline station, the message "Measured value invalid" (error code 8004_{hex}) appears in the process data input words. After a maximum of one second, the preset parameterization is accepted and the first measured value is available.

If you change the parameterization, the corresponding channel is re-initialized.

The message "Measured value invalid" (error code 8004_{hex}) appears in the process data output words for maximum 100 ms.

The following values are preset on the terminal:

Connection	3-wire technology
R_0	100 Ω
Format	IB IL
Sensor type	Pt 100 DIN

Order of the process data words:

OUT0	OUT1
Channel 1	Channel 2

Assignment of the parameter words (OUT0 and OUT1)

15	14	13	12	11	10	9	8	7	6	5	4	3	2	1	0
Parameterization	Reserved	Connection	R ₀				Resolution	Format	Sensor type						

Bit 15

Code		Parameterization
dec	bin	
0	0	Default
1	1	Parameterization

When bit 15 = 0, the preset (default) is active.

In order to parameterize the terminal, set bit 15 to 1.

Bit 14

Bit 14 is reserved. Set this bit to 0.

Bit 13 ... 12

Code		Connection
dec	bin	
0	00	3-wire (default)
1	01	2-wire
2	10	4-wire (channel 1 only)
3	11	Reserved

Bit 11 ... 8

Code		R ₀
dec	bin	Ω
0	0000	100
1	0001	10
2	0010	20
3	0011	30
4	0100	50
5	0101	120
6	0110	150
7	0111	200
8	1000	240
9	1001	300
10	1010	400
11	1011	500
12	1100	1000
13	1101	1500
14	1110	2000
15	1111	3000 (adjustable)

Bit 7 ... 6

Code		Resolution for sensor type			
dec	bin	0 ... 10	13	14	15
0	00	0.1°C (default)	1 %	0.1 Ω	1 Ω
1	01	0.01°C	0.1 %	0.01 Ω	0.1 Ω
2	10	0.1°F	Reserved		
3	11	0.01°F			

Bit 5 ... 4

Code		Format
dec	bin	
0	00	IB IL
1	01	IB ST (12 bits)
2	10	IB RT (15 Bit)
3	11	Reserved

See also Section "Measured value representation in the different formats".

Bit 3 ... 0

Code		Sensor type
dec	bin	
0	0000	Pt DIN
1	0001	Pt SAMA
2	0010	Ni DIN
3	0011	Ni SAMA
4	0100	Cu 10
5	0101	Cu 50
6	0110	Cu 53
7	0111	Ni 1000 (Landis & Gyr)
8	1000	Ni 500 (Viessmann)
9	1001	KTY 81-110
10	1010	KTY 84
11	1011	Reserved
12	1100	Reserved
13	1101	Potentiometer
14	1110	Linear R 0 Ω ... 400 Ω
15	1111	Linear R 0 Ω ... 4 k Ω



Set all reserved bits to 0.

14.2 IN process data

The measured values and diagnostic messages (in the IB IL format) are transmitted channel-by-channel to the controller via the process data input words IN0 and IN1.

Order of the process data words:

IN0	IN1
Channel 1	Channel 2

Open circuit/short circuit detection

An open circuit/short circuit is detected by the terminal according to the following table.

Faulty sensor cable	Temperature measuring range			Resistance measuring range		
	2-wire	3-wire	4-wire	2-wire	3-wire	4-wire
I+	Yes	Yes	Yes	Yes	Yes	No
I-	Yes	Yes	Yes	Yes	Yes	No
U+	-	-	Yes	-	-	Yes
U-	-	Yes	Yes	-	Yes	Yes

Yes Open circuit/short circuit is detected.

- The cable is not connected when using this connection technology.

No Open circuit/short circuit is not detected because the value is a valid measured value.

14.3 Assignment of the terminal points to IN process data

(Word.bit) view	Word	Word x															
		Bit		15	14	13	12	11	10	9	8	7	6	5	4	3	2
(Byte.Bit) view	Byte	Byte 0								Byte 1							
		Bit		7	6	5	4	3	2	1	0	7	6	5	4	3	2
Channel 1	Signal	Terminal point 1.1: I1+															
	Signal reference	Terminal point 1.2: I1-								Terminal point 1.3: U1+							
	Shielding	Terminal point 1.4															
Channel 2	Signal	Terminal point 2.1: I2+															
	Signal reference	Terminal point 2.2: I2-								Terminal point 2.3: U1+							
	Shielding	Terminal point 2.4															

Word x	Channel
IN0	1
IN1	2

15 Formats for representing measured values



Phoenix Contact recommends format IB IL for all controllers as this format contains the most comprehensive diagnostic codes.

The other formats are only intended for simplifying reconfiguration on IB IL analog modules in existing projects.

15.1 IB IL format

The measured value is represented in bits 14 to 0. An additional bit (bit 15) is available as a sign bit.

This format supports extended diagnostics. Values > 8000_{hex} indicate an error.

Supported error codes

Code (hex)	Error
8001	Measuring range exceeded (overrange)
8002	Open circuit or short circuit (only available for this temperature range)
8004	Measured value invalid or no valid measured value available
8010	Configuration invalid
8040	Device faulty
8080	Below measuring range (underrange)

Measured value representation in IB IL format

15	14	13	12	11	10	9	8	7	6	5	4	3	2	1	0
V	Analog value														

V Sign bit

Significant measured values

Sensor type (bits 3 ... 0)		0 ... 10	13	14	15
Resolution (bits 7 ... 6)		00 _{bin} or 10 _{bin}	00 _{bin}	00 _{bin}	00 _{bin}
Process data item (= analog value)		0.1°C or 0.1°F	1 %	0.1 Ω	1 Ω
hex	dec	°C or °F	%	Ω	Ω
8002	-	Open circuit	-	-	-
8001	-	Overrange	-	400	400
2710	10000	1000.0	-	-	-
0FA0	4000	400,0	4000 (40 x R ₀)	400	4000
000A	10	1.0	10 (0.10 x R ₀)	1.0	10
0001	1	0.1	1 (0.01 x R ₀)	0.1	1
0000	0	0	0	0	0
FFFF	-1	-0.1	-	-	-
FC18	-1000	-100.0	-	-	-
8080		Measuring range underrange	-	-	-
8002		Short-circuit	-	-	-

Sensor type (bits 3 ... 0)		0 ... 10	13	14	15
Resolution (bits 7 ... 6)		01 _{bin} or 11 _{bin}	01 _{bin}	01 _{bin}	01 _{bin}
Process data item (= analog value)		0.01°C or 0.01°F	0.1 %	0.01 Ω	0.1 Ω
hex	dec	°C or °F	%	Ω	Ω
8002	-	Open circuit	-	-	-
8001	-	Overrange	-	325.12	3251.2
2710	10000	100.00	1000.0 (10 x R ₀)	1000.0	-
03E8	1000	10.00	100.0 (1 x R ₀)	10.00	100.0
0001	1	0.01	0.1 (0.01 x R ₀)	0.01	0.1
0000	0	0	0	0	0
FFFF	-1	-0.01	-	-	-
D8F0	-10000	-100.0	-	-	-
8080		Measuring range underrange	-	-	-
8002		Short-circuit	-	-	-



If the measured value is outside the representation range of the process data, the "Overrange" or "Underrange" error message is generated.

15.2 IB ST format

The measured value is represented in bits 14 to 3.

An additional bit (bit 15) is available as a sign bit.

IB ST format corresponds to the data format used on INTERBUS ST modules.

Measured value representation in IB ST format

15	14	13	12	11	10	9	8	7	6	5	4	3	2	1	0
V	Analog value												0	OC	BÜ

V	Sign bit
0	Reserved
OC	Open circuit
BÜ	Overrange

Significant measured values

Sensor type (bits 3 ... 0)		RTD sensor (0 ... 13)	
Resolution (bits 7 ... 6)		00 _{bin} or 10 _{bin}	01 _{bin} or 11 _{bin}
Process data item (= analog value)		0.1°C or 0.1°F	0.01°C or 0.01°F
hex	dec	°C or °F	°C or °F
xxxx xxxx xxxx xxx1 _{bin}		Overrange (AV = positive final value for the measuring range)	
2710	10000	1000.0	100.00
03E8	1000	100.0	10.00
0008	8	0.8	0.08
0000	0	0	0
FFF8	-8	-0.8	-0.08
FC18	-1000	-100.0	-10.00
xxxx xxxx xxxx xxx1 _{bin}		Underrange (AV = negative final value for the measuring range)	
xxxx xxxx xxxx xx1x _{bin}		Open circuit/short circuit (AV = negative final value for the measuring range)	

AV	Analog value
x	Can have the value 0 or 1



If the measured value is outside the display area of the process data, bit 0 is set to 1.
In the event of an open/short circuit, bit 1 is set to 1.

15.3 IB RT format

The measured value is represented in bits 14 to 0. An additional bit (bit 15) is available as a sign bit.

IB RT format corresponds to the data format used on INTERBUS RT modules.

Measured value representation in IB RT format

15	14	13	12	11	10	9	8	7	6	5	4	3	2	1	0
V	Analog value														

V Sign bit

Significant measured values

Sensor type (bits 3 ... 0)		RTD sensor (0 ... 10)	Linear resistance (15)
Resolution (bits 7 ... 6)		00 _{bin} or 10 _{bin}	00 _{bin}
Process data item (= analog value)		0.1°C or 0.1°F	1 Ω
hex	dec	°C or °F	Ω
7FFF	32767	-	> 2048
Upper limit value + 1 LSB		Measuring range exceeded (overrange)	-
7D00	32000	-	2000
2710	10000	1000.0	625
000A	10	1	0.625
0001	1	0.1	0.0625
0000	0	0	0
FFFF	-1	-0.1	-
FC18	-1000	-100.0	-
Lower limit value - 1 LSB		Below measuring range (underrange)	-
Lower limit value - 2 LSB		Open circuit/short circuit	-

Sensor type (bits 3 ... 0)		RTD sensor (0 ... 10)	Linear resistance (15)
Resolution (bits 7 ... 6)		01 _{bin} or 11 _{bin}	01 _{bin}
Process data item (= analog value)		0.01°C or 0.01°F	0.1 Ω
hex	dec	°C or °F	Ω
7FFF	32767	-	> 4096
Upper limit value + 1 LSB		Measuring range exceeded (overrange)	-
7D00	32000	320.00	4000
2710	10000	100.0	1250
0001	1	0.1	0.125
0000	0	0	0
FFFF	-1	-0.1	-
D8F0	-10000	-100.0	-
Lower limit value - 1 LSB		Below measuring range (underrange)	-
Lower limit value - 2 LSB		Open circuit/short circuit	-

16 Measuring ranges

16.1 Measuring ranges depending on the resolution (IB IL format)

Resolution		Measuring range of the temperature sensors
Bit 7 ... 6		
00	0.1°C	-273 °C ... +3276.8 °C
01	0.01°C	-273 °C ... +327.68 °C
10	0.1°F	-459 °F ... +3276.8 °F
11	0.01°F	-459 °F ... +327.68 °F



Temperature values in °C can be converted to °F using the following formula:

$$T [^{\circ}\text{F}] = T [^{\circ}\text{C}] \times 9/5 + 32$$

Where:

T [°F] Temperature in °F

T [°C] Temperature in °C

16.2 Input measuring ranges

No.	Input	Sensor type	R ₀	Standard	Measuring range	
					Lower limit	Upper limit
0	Temperature sensors	Pt	10 Ω ... 3000 Ω	acc. to DIN	-200 °C	+850 °C
1		Pt	10 Ω ... 3000 Ω	acc. to SAMA	-200 °C	+850 °C
2		Ni	10 Ω ... 3000 Ω	acc. to DIN	-60 °C	+180 °C
3		Ni	10 Ω ... 3000 Ω	acc. to SAMA	-60 °C	+180 °C
4		Cu 10			-70 °C	+500 °C
5		Cu 50			-50 °C	+200 °C
6		Cu 53			-50 °C	+180 °C
7		Ni 1000 (L&G)			-50 °C	+160 °C
8		Ni 500 (Viessmann)			-60 °C	+250 °C
9		KTY 81-110			-55 °C	+150 °C
10	KTY 84			-40 °C	+300 °C	
11	Reserved					
12						
13	Relative potentiometer range				0 %	4 kΩ / R ₀ x 100 % (max. 400 %)
14	Linear resistance range				0 Ω	400 Ω
15					0 Ω	4000 Ω

17 Measuring error

17.1 Systematic measuring errors during temperature measurement using resistance thermometers

When measuring temperatures using resistance thermometers, systematic measuring errors are often the cause for incorrect measuring results.

There are three main ways to connect the sensors: 2-, 3-, and 4-wire technology.

17.1.1 4-wire technology

Using 4-wire technology is the most precise way of measuring.

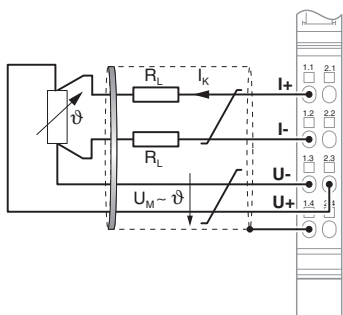

Figure 9 Connection of resistance thermometers with 4-wire technology

When using the 4-wire technology, a constant current is sent through the sensor via wires I+ and I-. With the other two wires U+ and U-, the temperature-related voltage is tapped and measured at the sensor. The cable resistances have absolutely no effect on the measurement.

17.1.2 3-wire technology

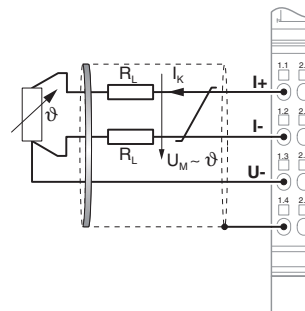

Figure 10 Connection of resistance thermometers with 3-wire technology

With 3-wire technology, the effect of the cable resistance on the measured result in the terminal is eliminated or minimized through multiple measurements of the temperature-related voltage and corresponding calculations. The quality of the results is almost as good as when using 4-wire technology. However, the 4-wire technology provides better results in environments subject to heavy noise.

17.1.3 2-wire technology

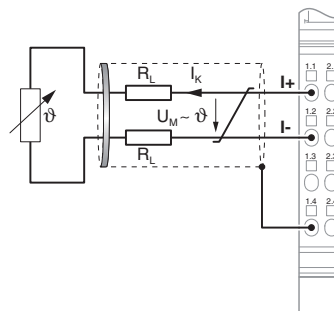

Figure 11 Connection of resistance thermometers with 2-wire technology

17.2 Systematic errors during temperature measurement using 2-wire technology

Diagram 1

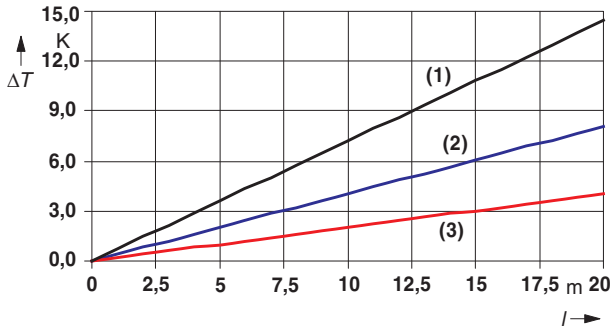

Figure 12 Systematic temperature measuring error ΔT depending on the cable length l

Curves depending on cable cross section A

- 1 Temperature measuring error for $A = 0.14 \text{ mm}^2$
- 2 Temperature measuring error for $A = 0.25 \text{ mm}^2$
- 3 Temperature measuring error for $A = 0.50 \text{ mm}^2$

(Measuring error valid for: copper cable $\chi = 57 \text{ m}/\Omega\text{mm}^2$, $T_A = 25^\circ\text{C}$ and Pt 100 sensor)

Diagram 2

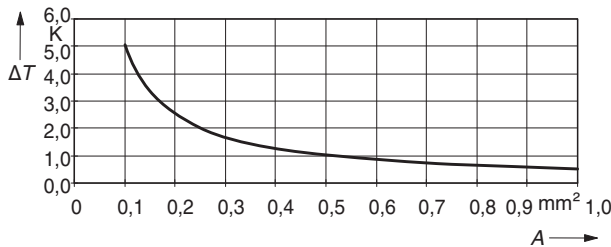

Figure 13 Systematic temperature measuring error ΔT depending on the cable cross section A

(Measuring error valid for: copper cable $\chi = 57 \text{ m}/\Omega\text{mm}^2$, $T_A = 25^\circ\text{C}$, $l = 5 \text{ m}$, and Pt 100 sensor)

Diagram 3

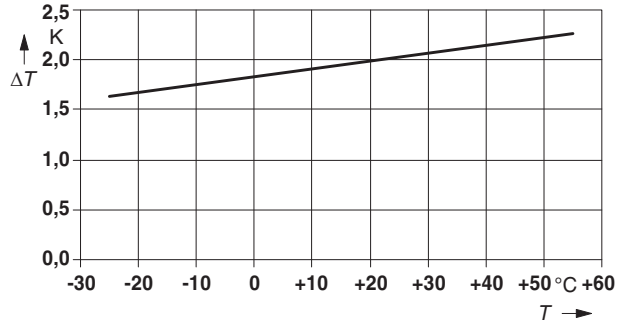

Figure 14 Systematic temperature measuring error ΔT depending on the cable temperature T

(Measuring error valid for: copper cable $\chi = 57 \text{ m}/\Omega\text{mm}^2$, $T_A = 25^\circ\text{C}$, $l = 5 \text{ m}$, $A = 0.25 \text{ mm}^2$, and Pt 100 sensor)

Conclusion

All diagrams show that the increase in cable resistance causes the measuring error.

A considerable improvement is made when Pt 1000 sensors are used. Due to the 10-fold higher temperature coefficient α ($\alpha = 0.385 \text{ } \Omega/\text{K}$ for Pt 100 to $\alpha = 3.85 \text{ } \Omega/\text{K}$ for Pt 1000) the effect of the cable resistance on the measurement is decreased by factor 10. All errors in the diagrams above would be reduced by factor 10.

Diagram 1 clearly shows the effect of the cable length on the cable resistance and therefore on the measuring error. The solution is to use the shortest possible sensor cables.

Diagram 2 shows the influence of the cable diameter on the cable resistance. It can be seen that cables with a diameter of less than 0.5 mm^2 cause the error to increase exponentially.

Diagram 3 shows the influence of the ambient temperature on the cable resistance. This parameter is of minor importance and can hardly be influenced. It is mentioned here only for the sake of completeness.

The formula for calculating the cable resistance is as follows:

$$R_L = R_{L20} \times \left(1 + 0,0039 \frac{1}{K} \times (T - 20^\circ\text{C}) \right)$$

$$R_L = \frac{l}{\chi \times A} \times \left(1 + 0,0039 \frac{1}{K} \times (T - 20^\circ\text{C}) \right)$$

Where:

R_L	Cable resistance in Ω
R_{L20}	Cable resistance at 20°C in Ω
l	Cable length in m
χ	Specific electrical resistance of copper in $\text{m}/\Omega\text{mm}^2$
A	Cable cross section in mm^2
0.0039 1/K	Temperature coefficient for copper (percentage purity of 99.9%)
T	Ambient temperature (cable temperature) in °C

Since there are two cable resistances in the measuring system (forward and return), the value must be doubled. The absolute measuring error in Kelvin [K] is provided for platinum detectors according to DIN using the average temperature coefficient χ ($\chi = 0.385 \Omega/\text{K}$ for Pt 100; $\chi = 3.85 \Omega/\text{K}$ for Pt 1000).



SCATTERGOOD & JOHNSON LTD

ELECTRICAL ENGINEERING & FLUID CONTROL DISTRIBUTORS

At Scattergood & Johnson Ltd, we pride ourselves on being a technical distributor to specialist industries.

Working with a range of quality product suppliers across a number of specialist markets, we are not your average 'box shifter' - we are your technical and supply chain partner.

We fully support every product we sell - for free! Our internal team and external sales engineers can answer any product or application question, no matter the complexity.

Backing up this technical ability is a range of 50,000+ products available from stock for nationwide next day delivery (same day if required!), or you can collect what you need from any of our trade counters around the UK.

Select your specialist interest below to learn more about how we can help.

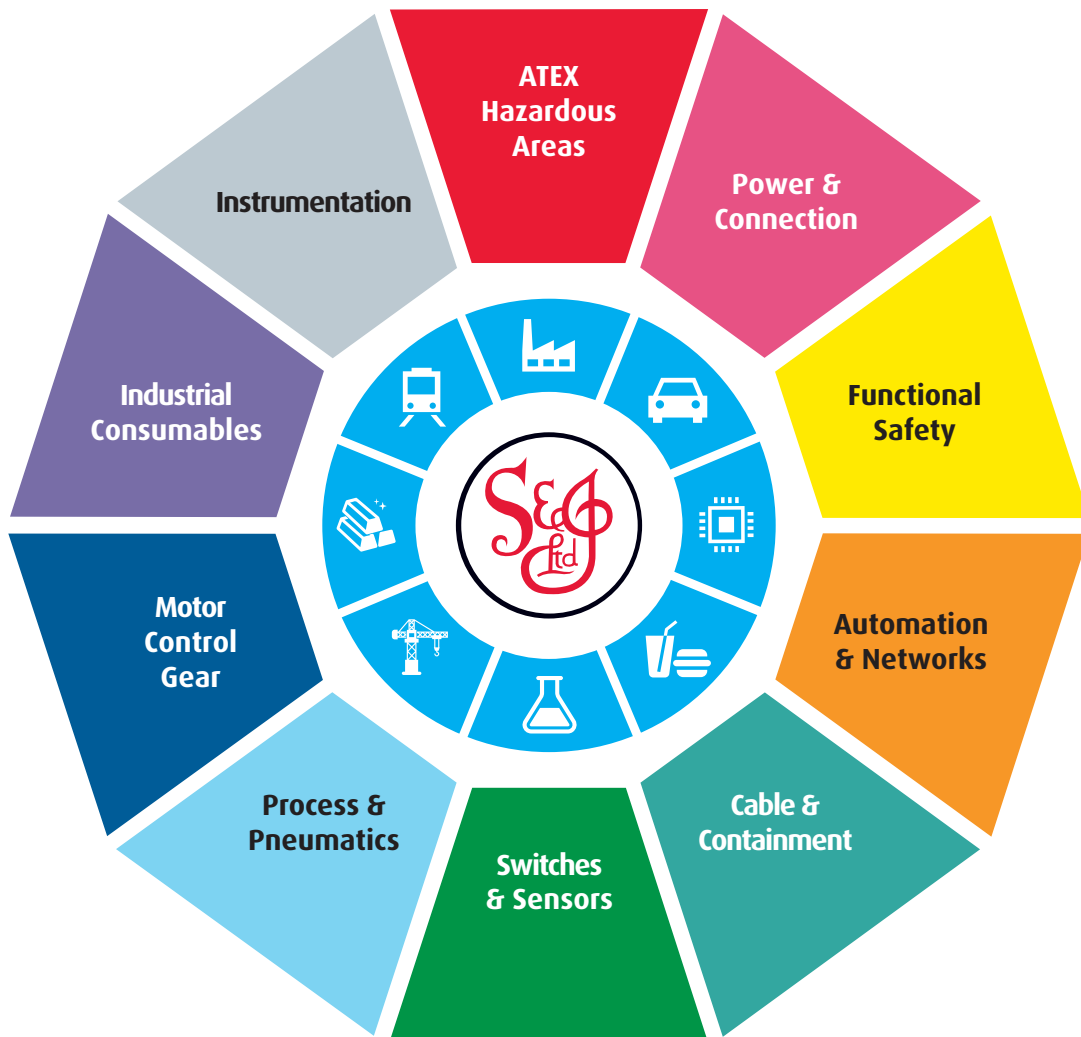

Online, In Branch and On the Road - Scattergood & Johnson Ltd, there when you need us.

www.scatts.co.uk