

IB IL AI 8/SF(-2MBD)-PAC

**Inline, analog input terminal,
analog inputs: 8 (for connection of voltage or
current signals)**

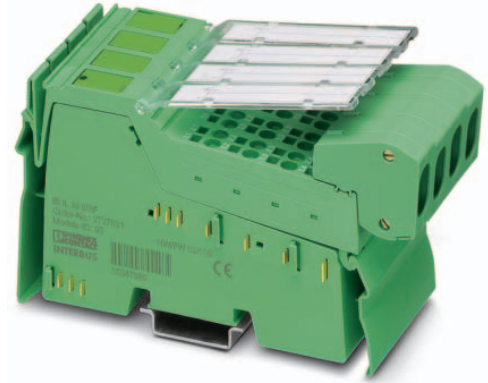

Data sheet
6226_en_07_C01

© PHOENIX CONTACT 2019-02-05

1 Description

The terminal is designed for use within an Inline station.
It is used to acquire analog voltage and current signals.

Features

- 8 analog single-ended signal inputs for the connection of either voltage or current signals
- Connection of sensors in 2-wire technology
- Current ranges: 0 mA ... 20 mA, 4 mA ... 20 mA, ±20 mA, 0 mA ... 40 mA, ±40 mA
- Voltage ranges: 0 V ... 5 V, ±5 V, 0 V ... 10 V, ±10 V, 0 V ... 25 V, ±25 V, 0 V ... 50 V
- Channels are parameterized independently of one another via the bus system
- Measured values can be represented in five different formats
- 16-bit analog/digital converter
- Process data multiplex mode
- High measuring accuracy
- **IB IL AI 8/SF-PAC**
As of hardware revision 02:
Approved for use in Zone 2 potentially explosive areas



IB IL AI 8/SF-PAC

WARNING: Explosion hazard when used in potentially explosive areas

When using the terminal in potentially explosive areas, observe the corresponding notes.



This data sheet is only valid in association with the IL SYS INST UM E user manual.



Make sure you always use the latest documentation.

It can be downloaded from the product at [phoenixcontact.net/products](https://www.phoenixcontact.net/products).

2	Table of contents	
1	Description	1
2	Table of contents	2
3	Ordering data	3
4	Technical data	4
5	Additional tables	7
6	Tolerance data.....	8
7	Internal circuit diagram	10
8	Electrical isolation.....	10
9	Notes on using the terminal block in potentially explosive areas	11
10	Terminal point assignment.....	12
11	Installation instructions	13
12	Connection notes	13
13	Connection example.....	13
14	Local diagnostic and status indicators	13
15	Process data.....	14
16	Formats for representing measured values	19
17	IN process data in the event of an error	28
18	Startup options	29
19	Application notes	34

3 Ordering data

Description	Type	Order No.	Pcs./Pkt.
Inline, Analog input terminal, Analog inputs: 8, 0 V ... 5 V, -5 V ... 5 V, 0 V ... 10 V, -10 V ... 10 V, 0 V ... 25 V, -25 V ... 25 V, 0 V ... 50 V, 0 mA ... 20 mA, 4 mA ... 20 mA, -20 mA ... 20 mA, 0 mA ... 40 mA, -40 mA ... 40 mA, Connection technology: 2-wire, Transmission speed in the local bus 500 kbps, Degree of protection IP20, including Inline connectors and marking fields	IB IL AI 8/SF-PAC	2861412	1
Inline, Analog input terminal, Analog inputs: 8, 0 V ... 5 V, -5 V ... 5 V, 0 V ... 10 V, -10 V ... 10 V, 0 V ... 25 V, -25 V ... 25 V, 0 V ... 50 V, 0 mA ... 20 mA, 4 mA ... 20 mA, -20 mA ... 20 mA, 0 mA ... 40 mA, -40 mA ... 40 mA, Connection technology: 2-wire, Transmission speed in the local bus 2 Mbps, Degree of protection IP20, including Inline connectors and marking fields	IB IL AI 8/SF-2MBD-PAC	2862042	1
Accessories	Type	Order No.	Pcs./Pkt.
Inline shield connector (Connector/Adapter)	IB IL SCN 6-SHIELD-TWIN	2740245	5
Labeling field, width: 48.8 mm (Marking)	IB IL FIELD 8	2727515	10
Insert strip, Sheet, white, unlabeled, can be labeled with: Office printing systems: Laser printer, Mounting type: Insert, Lettering field: 62 x 46 mm (Marking)	ESL 62X46	0809502	5
Labeling field, width: 12.2 mm (Marking)	IB IL FIELD 2	2727501	10
Insert strip, Sheet, white, unlabeled, can be labeled with: Office printing systems: Laser printer, Mounting type: Insert, Lettering field: 62 x 10 mm (Marking)	ESL 62X10	0809492	1
Documentation	Type	Order No.	Pcs./Pkt.
User manual, English, Automation terminals of the Inline product range	IL SYS INST UM E	-	-
Data sheet, English, INTERBUS addressing	DB GB IBS SYS ADDRESS	-	-
Application note, English, Inline terminals for use in zone 2 potentially explosive areas	AH EN IL EX ZONE 2	-	-

4 Technical data

Dimensions (nominal sizes in mm)

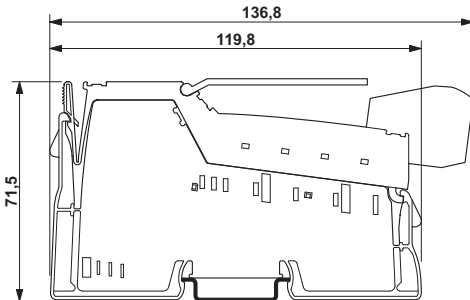

Width	48.8 mm
Height	136.8 mm
Depth	71.5 mm
Note on dimensions	Housing dimensions

General data

Color	green
Weight	213 g (with connectors)
Operating mode	Process data operation with 2 words
Ambient temperature (operation)	-25 °C ... 55 °C
Ambient temperature (storage/transport)	-25 °C ... 85 °C
Permissible humidity (operation)	10 % ... 95 % (non-condensing)
Permissible humidity (storage/transport)	10 % ... 95 % (non-condensing)
Air pressure (operation)	70 kPa ... 106 kPa (up to 3000 m above sea level)
Air pressure (storage/transport)	70 kPa ... 106 kPa (up to 3000 m above sea level)
Degree of protection	IP20
Protection class	III, IEC 61140, EN 61140, VDE 0140-1

Connection data

Designation	Inline connector
Connection method	Spring-cage connection
Conductor cross section solid / stranded	0.08 mm ² ... 1.5 mm ² / 0.08 mm ² ... 1.5 mm ²
Conductor cross section [AWG]	28 ... 16
Stripping length	8 mm

Connection data for UL approvals

Designation	Inline connector
Connection method	Spring-cage connection

Connection data for UL approvals

Conductor cross section solid / stranded	0.2 mm ² ... 1.5 mm ² / 0.2 mm ² ... 1.5 mm ²
Conductor cross section [AWG]	24 ... 16
Stripping length	8 mm

Interface Inline local bus

Connection method	Inline data jumper
Transmission physics	Copper

Transmission speed Inline local bus

IB IL AI 8/SF-PAC	500 kbps
IB IL AI 8/SF-2MBD-PAC	2 Mbps

Inline potentials / Power consumption (500 kbps)

Communications power U_L	7.5 V DC
Current consumption from U_L	max. 55 mA typ. 48 mA
I/O supply voltage U_{ANA}	24 V DC
Current consumption from U_{ANA}	max. 35 mA typ. 24 mA
Power consumption	typ. 936 mW (entire device)

Inline potentials / Power consumption (2 Mbps)

Communications power U_L	7.5 V DC
Current consumption from U_L	max. 85 mA typ. 68 mA
I/O supply voltage U_{ANA}	24 V DC
Current consumption from U_{ANA}	max. 38 mA typ. 24 mA
Power consumption	typ. 1086 mW (entire device)

Analog inputs

Number of inputs	8
Description of the input	Single-ended inputs, voltage or current
Connection method	Inline shield connector
Connection technology	2-wire, Shielded
Current input signal	0 mA ... 20 mA, 4 mA ... 20 mA, -20 mA ... 20 mA, 0 mA ... 40 mA, -40 mA ... 40 mA
Voltage input signal	0 V ... 5 V, -5 V ... 5 V, 0 V ... 10 V, -10 V ... 10 V, 0 V ... 25 V, -25 V ... 25 V, 0 V ... 50 V
Max. permissible current	± 100 mA (per input)
Resolution A/D	16 bit
A/D conversion time	approx. 10 µs
Limit frequency (3 dB)	3.5 kHz
Measured value representation	16 bit two's complement
Data formats	IB IL, IB ST, IB RT, standardized representation, PIO format
Process data update	bus-synchronous

Analog inputs	
Filtering	1st order low pass
Input resistance of voltage input	> 240 k Ω
Input resistance current input	25 Ω (Shunt)
Limit frequency (3 dB)	3.5 kHz
Open circuit response	goes to 0 V, 0 mA or 4 mA
Permissible voltage	max. 50 V (between analog voltage inputs and analog reference potential) max. 50 V (between two voltage inputs) max. ± 2.5 V (between analog current inputs and analog reference potential, correspond to 100 mA through the shunts) max. ± 2.5 V (between two current inputs, correspond to 100 mA through the shunts)
Surge protection, overcurrent protection	max. 100% overload (in relation to the nominal value)

Programming data (INTERBUS, local bus)	
ID code (hex)	5F
ID code (dec.)	95
Length code (hex)	02
Length code (dec.)	02
Process data channel	32 Bit
Input address area	4 Byte
Output address area	4 Byte
Parameter channel (PCP)	0 Byte
Register length (bus)	32 Bit

Configuration and parameter data in a PROFIBUS system	
Required parameter data	6 Byte
Need for configuration data	5 Byte

Error messages to the higher level control or computer system	
Failure of the power supply at U_{ANA}	
Peripheral fault	Error message in the process data
User error	Error message in the process data

Electrical isolation/isolation of the voltage areas	
Test section	Test voltage
7.5 V supply (bus logic), 24 V supply U_{ANA} / I/O	500 V AC, 50 Hz, 1 min.
7.5 V supply (bus logic), 24 V supply U_{ANA} /functional earth ground	500 V AC, 50 Hz, 1 min.
I/O / functional earth ground	500 V AC, 50 Hz, 1 min.

Approvals	
For the latest approvals, please visit phoenixcontact.net/products .	

5 Additional tables

Firmware runtime



The firmware runtime contains the times for the following actions:

- Signal acquisition
- Signal conditioning
- Mean-value generation
- Standardization
- Transfer of the measured values to the process data registers

Command code hex	Firmware runtime
0x00	< 800 μ s
5x00	< 850 μ s
7000, 7100	< 1500 μ s
7400, 7500, 7600, 7700	< 1300 μ s

6 Tolerance data



The percentage tolerance values refer to the relevant positive measuring range final value. Unless stated otherwise, nominal operation (nominal voltage, preferred mounting position, default format setting, default filter setting, identical measuring range setting for all channels) is used as the basis. The tolerance values refer to the operating temperature range specified in the tables. The operable range outside this temperature range is not taken into consideration. Please also take into consideration the tolerances influenced by electromagnetic interference.

The maximum tolerance values represent the worst-case measurement inaccuracy. They contain the theoretical maximum possible tolerances in the corresponding measuring ranges as well as the theoretical maximum possible tolerances of the calibration and test equipment.

6.1 Tolerance and temperature response of the voltage inputs

Measuring range	Absolute		Relative	
	Typical	Maximum	Typical	Maximum
T_A = 25 °C				
0 V ... 5 V, ±5 V	±1.0 mV	±5.0 mV	±0.02%	±0.10%
0 V ... 10 V, ±10 V	±2.0 mV	±10.0 mV	±0.02%	±0.10%
0 V ... 25 V, ±25 V	±5.0 mV	±25.0 mV	±0.02%	±0.10%
0 V ... 50 V	±10.0 mV	±50.0 mV	±0.02%	±0.10%
T_U = -25 °C ... +55 °C				
0 V ... 5 V, ±5 V	±5.0 mV	±15.0 mV	±0.10%	±0.30%
0 V ... 10 V, ±10 V	±10.0 mV	±30.0 mV	±0.10%	±0.30%
0 V ... 25 V, ±25 V	±25.0 mV	±75.0 mV	±0.10%	±0.30%
0 V ... 50 V	±50.0 mV	±150.0 mV	±0.10%	±0.30%

6.2 Tolerance and temperature response of the current inputs

Measuring range	Absolute		Relative	
	Typical	Maximum	Typical	Maximum
T_A = 25 °C				
0 mA ... 20 mA, 4 mA ... 20 mA, ±20 mA	±8.0 μA	±40.0 μA	±0.04 %	±0.20 %
0 mA ... 40 mA, ±40 mA	±16.0 μA	±80.0 μA	±0.04 %	±0.20 %
T_U = -25 °C ... +55 °C				
0 mA ... 20 mA, 4 mA ... 20 mA, ±20 mA	±28.0 μA	±80.0 μA	±0.14 %	±0.40 %
0 mA ... 40 mA, ±40 mA	±56.0 μA	±160.0 μA	±0.14 %	±0.40 %

6.3 Additional tolerances influenced by electromagnetic interference

Type of electromagnetic interference		Typical deviation from the measuring range final value	
		Voltage input	Current input
		Relative	Relative
Electromagnetic fields	EN 61000-4-3/IEC 61000-4-3	< ±2.0 %	< ±2.0 %
Fast transients (burst)	EN 61000-4-4/IEC 61000-4-4	< ±1.0 %	< ±1.0 %
Conducted interference	EN 61000-4-6/IEC 61000-4-6	< ±1.0 %	< ±1.0 %

7 Internal circuit diagram

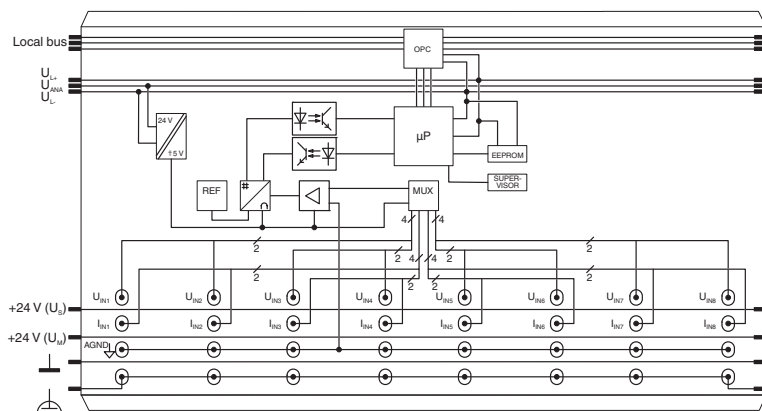
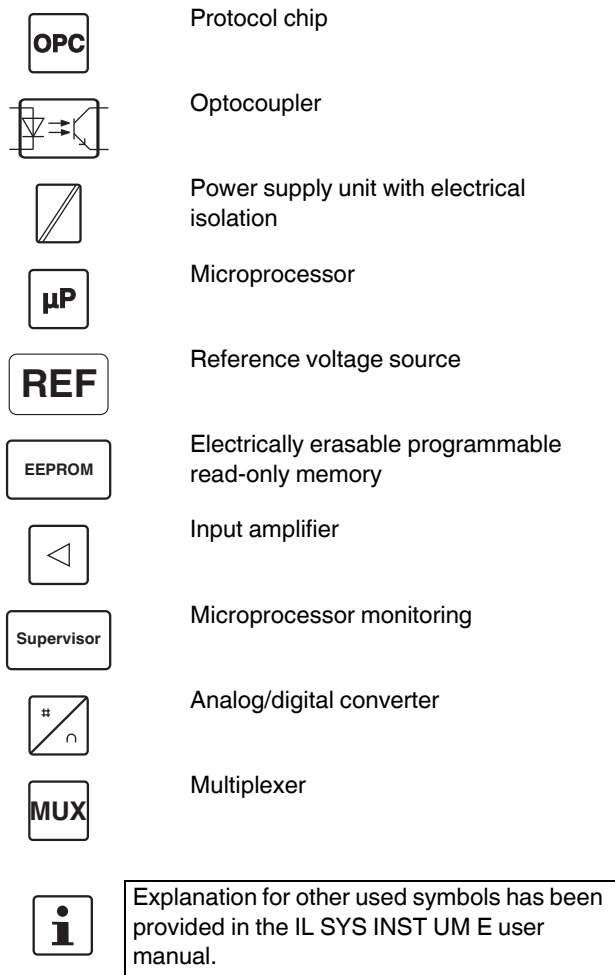

Figure 1 Internal wiring of the terminal points

Key:



8 Electrical isolation

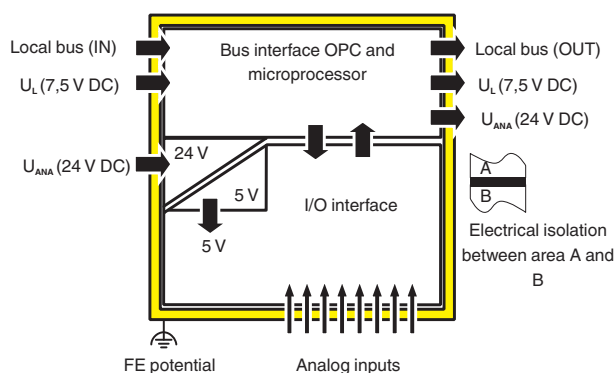

Figure 2 Electrical isolation of the individual function areas

9 Notes on using the terminal block in potentially explosive areas



WARNING: Explosion hazard

Please make sure that the following notes and instructions are observed.

Valid for: IB IL AI 8/SF-PAC

Approval according to ATEX Directive 2014/34/EU

Ⓜ II 3 G Ex nA IIC T4 Gc X

Installation notes

The category 3 device is designed for installation in zone 2 potentially explosive areas.

The device meets the requirements of EN 60079-0:2012 + A11:2013 and EN 60079-15:2010.

- Observe the specified conditions for use in potentially explosive areas.
- At the time of installation, use an approved housing (minimum protection IP54), which meets the requirements of EN 60079-15. Within this context, observe the requirements of IEC 60079-14/EN 60079-14.
- The following work is only permitted in potentially explosive areas when the power is disconnected:
 - Snapping the device onto the DIN rail
 - Removing the device from the DIN rail
 - Connection and disconnection of cables
- Only devices that are designed for operation in Ex Zone 2 and the conditions at the installation location may be connected to the circuits in Zone 2.
- The maximum permissible current for each tension spring contact is **2 A**.
- When using the device in potentially explosive areas, observe the specifications in the application note AH DE IL EX ZONE 2 (German) / AH EN IL EX ZONE 2 (English).



IB IL AI 8/SF-2MBD-PAC

The terminal was approved for use in potentially explosive areas of Zone 2 according to the ATEX directive until the start of 2017 and marked accordingly (Ⓜ).

If you are using a terminal of this type in a potentially explosive area, observe the associated terminal-specific documentation.

See also the information in application note AH DE IL SAFE (German) or AH EN IL SAFE (English).

Terminals without corresponding marking (Ⓜ) are not approved for use in potentially explosive areas.

10 Terminal point assignment

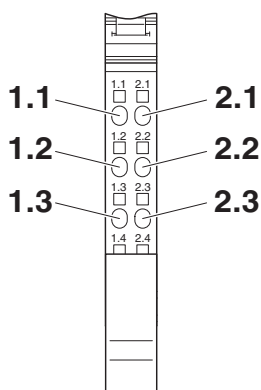

Figure 3 Terminal point assignment

The printing on the four connectors of the module is identical.

Terminal point	Signal				Meaning
	Connector 1	Connector 2	Connector 3	Connector 4	
1.1	U01+	U03+	U05+	U07+	Voltage input, channel x
2.1	U02+	U04+	U06+	U08+	Voltage input, channel y
1.2	I01+	I03+	I05+	I07+	Current input, channel x
2.2	I02+	I04+	I06-	I08+	Current input, channel y
1.3	U01-/I01-	U03-/I03-	U05-/I05-	U07-/I07-	Minus input, channel x (common for current and voltage)
2.3	U02-/I02-	U04-/I04-	U06-/I06-	U08-/I08-	Minus input, channel y (common for current and voltage)
1.4, 2.4	Shield	Shield	Shield	Shield	Shield connection

Connector 1 2 3 4
 Channel x / y 01 / 02 03 / 04 05 / 06 07 / 08

11 Installation instructions

High current flowing through potential jumpers U_M and U_S leads to a temperature rise in the potential jumpers and inside the terminal. To keep the current flowing through the potential jumpers of the analog terminals as low as possible, always place the analog terminals at the end of the main circuit (for the sequence of the Inline terminals: see also IL SYS INST UM E user manual).

12 Connection notes



WARNING: invalid measured values

Do not apply current and voltage signals to one input channel simultaneously as you will not obtain valid measured values.



NOTE: Damage to the electronics

Do not connect voltages above ± 2.5 V to a current input. The module electronics will be damaged, as the maximum permissible current of ± 100 mA will be exceeded.

Always connect the analog sensors using shielded, twisted pair cables.

Connect the shielding to the terminal using the shield connection clamp. The clamp connects the shield directly to FE on the terminal side. Additional wiring is not required.

Insulate the shielding at the sensor or connect it with a high resistance and a capacitor to the FE potential.

13 Connection example

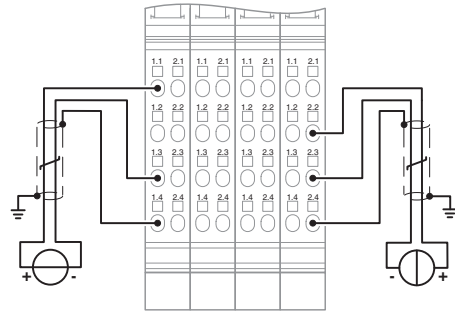

Figure 4 Connection of active sensors in 2-wire technology with shield connection

Left: Active sensor with voltage input (channel 1)
 Right: Active sensor with current input (channel 2)



The sensors have the same reference potential.

14 Local diagnostic and status indicators

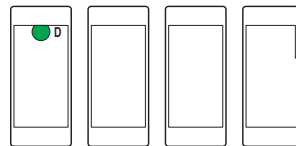

Figure 5 Local diagnostic and status indicators

Designation	Color	Meaning
D	Green	Diagnostics (bus and logic voltage)



For detailed information on diagnostics, please refer to the IL SYS INST UM E user manual.

Function identification

Green

15 Process data

The terminal uses two words of IN process data and two words of OUT process data.

The measured values and the diagnostic messages are transmitted via the IN process data.

You can parameterize the terminal channel by channel via the OUT process data.

15.1 OUT process data

Parameterize the terminal via the OUT process data.

Word OUT0 contains the command; word OUT1 contains the parameters for this command.

The following parameterization options are available:

- Selecting the measuring range according to the input signal
- Selection of mean-value generation
- Selecting the formats for representing measured values



Select whether a channel measures current or voltage by applying the measuring signal at the current or voltage input and then parameterizing the measuring range accordingly



After applying voltage (power up) to the Inline station, the message “Measured value invalid” (diagnostic code 8004_{hex}) appears in the IN process data for every channel requested. The message is displayed until the appropriate channel has been parameterized. If the parameterization is changed, the message “Measured value invalid” appears for a maximum of 100 ms. Please note the extended runtime when a channel is parameterized for the first time and every time a channel is reparameterized.

Order of the process data words:

OUT0	OUT1
------	------

15.2 OUT0: command code

OUT0																							
15	14	13	12	11	10	9	8	7	6	5	4	3	2	1	0								
0								Command								0	0	0	0	0	0	0	0



Set all reserved bits to 0.

Bit 15 ... 8

Bit 15 ... 8	OUT0 (hex)	Command function
0000 0KKK	0x00	Read measured value of channel x
0001 0KKK	1x00	Read parameterization of channel x
0011 1100	3C00	Read firmware version and module ID in IN1.
0100 0KKK	4x00	Parameterize channel x
0101 0KKK	5x00	Parameterize channel x and read measured value of channel x
0110 0000	6000	Parameterize entire terminal (all channels)
0111 0GGG	7x00	Commands for groups without mirroring

KKK Channel number
GGG Group number

Bit 10 ... 8

KKK

Code		Channel
dec	bin	
0	000	1
1	001	2
2	010	3
3	011	4
4	100	5
5	101	6
6	110	7
7	111	8

GGG

Code		Group
dec	bin	
0	000	4 x 8-bit group A (channel 1, 2, 3, and 4)
1	001	4 x 8-bit group B (channel 5, 6, 7, and 8)
2	010	Reserved
3	011	Reserved
4	100	2 x 16-bit group A (channel 1 and 2)
5	101	2 x 16-bit group B (channel 3 and 4)
6	110	2 x 16-bit group C (channel 5 and 6)
7	111	2 x 16-bit group D (channel 7 and 8)

15.3 OUT1: parameter word

Parameter word OUT1 is only evaluated for commands 4x00_{hex}, 5x00_{hex}, and 6000_{hex}.

For this command, specify the parameters in OUT1.

OUT1															
15	14	13	12	11	10	9	8	7	6	5	4	3	2	1	0
0	0	0	0	0	0	Filter	0	Format	Measuring range						



Set all reserved bits to 0.



If invalid parameters are specified in the parameter word, the command will not be executed. The command is acknowledged in the input words with the set error bit.

Bit 9 ... 8

Code		Filter
dec	bin	
0	00	16-sample mean-value (default)
1	01	No filter
2	10	4-sample mean-value
3	11	32-sample mean-value

Bit 6 ... 4

Code		Format
dec	bin	
0	000	IB IL (15 bits + sign bit, default)
1	001	IB ST (12 bits)
2	010	IB RT (15 Bit)
3	011	Standardized representation
4	100	PIO (for the 4 mA ... 20 mA range only)
5	101	Reserved
6	110	
7	111	

See also Section "Measured value representation in the different formats".

Bit 3 ... 0

Code		Measuring range
dec	bin	
0	0000	0 V ... 10 V (default)
1	0001	-10 V ... +10 V
2	0010	0 V ... 5 V
3	0011	-5 V ... +5 V
4	0100	0 V ... 25 V
5	0101	-25 V ... +25 V
6	0110	0 V ... 50 V
7	0111	Reserved
8	1000	0 mA ... 20 mA
9	1001	-20 mA ... +20 mA
10	1010	4 mA ... 20 mA
11	1011	Reserved
12	1100	0 mA ... 40 mA
13	1101	-40 mA ... +40 mA
14	1110	Reserved
15	1111	Reserved



WARNING: Electric shock

Make sure that the voltage difference between different terminal inputs does not exceed 50 V.

If, for example, you use the 0 V ... 50 V range on one channel, the use of bipolar ranges is not permitted on any other channel.

15.4 IN process data

The measured values and the diagnostic messages are transmitted via the IN process data.

The contents of the words differ depending on the commands.

Order of the process data words:

IN0	IN1
-----	-----

15.5 IN0 and IN1 for commands 0000_{hex} ... 6000_{hex}

IN0																
15	14	13	12	11	10	9	8	7	6	5	4	3	2	1	0	
EB	Mirrored command code							0	0	0	0	0	0	0	0	0

IN1															
15	14	13	12	11	10	9	8	7	6	5	4	3	2	1	0
Result															

15.5.1 IN0

Output word OUT0, which contains the command code, is mirrored in input word IN0. This confirms that the command has been executed correctly. If the command was not executed correctly, the error bit is set in bit 15 of input word IN0.

EB: Error Bit

- EB = 0 No error has occurred.
 EB = 1 An error has occurred.

The error bit indicates whether a command could be executed without errors or not.

Reasons for an error bit set:

- There is no valid parameterization for the channel requested.
- There was an invalid parameter during parameterization.
- At least one reserved bit has been set.

Mirrored command code

A command code mirrored from the control word. Here, the MSB is suppressed.

The command is only mirrored if it has been executed in full.

This means, for example, that command 5x00_{hex} is only mirrored after the value has been read and not after reparameterization.

15.5.2 IN1 for command 3C00_{hex}

For command 3C00_{hex}, IN1 provides the firmware version and the module ID.

The module ID for the terminal is 6_{hex}.

Example: Firmware version 1.23

IN1				
Bit	15 ... 12	11 ... 8	7 ... 4	3 ... 0
Assignment (hex)	1	2	3	3
Meaning	Firmware version 1.23			Module ID

15.5.3 IN1 for command 1x00_{hex}, 4x00_{hex}, and 6000_{hex}

For commands 1x00_{hex}, 4x00_{hex}, and 6000_{hex}, IN1 contains the mirroring of the specified parameterization.

IN1															
15	14	13	12	11	10	9	8	7	6	5	4	3	2	1	0
0	0	0	0	0	0	Filter	0	Format	Measuring range						

15.5.4 IN1 for command 0x00_{hex} and 5x00_{hex}

For commands 0x00_{hex} and 5x00_{hex}, IN1 contains the analog measured value.

IN1															
15	14	13	12	11	10	9	8	7	6	5	4	3	2	1	0
Measured value															

The measured value is represented according to the parameterized format, see the "Formats for representing measured values" section.

15.6 IN0 and IN1 for group commands 7x00_{hex}

IN0															
15	14	13	12	11	10	9	8	7	6	5	4	3	2	1	0
Result															

IN1															
15	14	13	12	11	10	9	8	7	6	5	4	3	2	1	0
Result															

For group commands 7x00_{hex}, both input words contain the measured values of the channels that correspond to the group command.

15.6.1 Group commands 7400_{hex}, 7500_{hex}, 7600_{hex}, and 7700_{hex}

These group commands apply for two 16-bit channels. The analog value of one channel is mapped to every input word. The representation corresponds to the representation in input word IN1 for commands 0x00_{hex} and 5x00_{hex}.

Example: command 7400_{hex}

2 x 16-bit group A (channels 1 and 2)

IN0															
15	14	13	12	11	10	9	8	7	6	5	4	3	2	1	0
16-bit measured value in the appropriate format															

IN1															
15	14	13	12	11	10	9	8	7	6	5	4	3	2	1	0
16-bit measured value in the appropriate format															

15.6.2 Group commands 7000_{hex} and 7100_{hex}

These group commands apply for four 8-bit channels. The analog values for two channels are mapped to every input word.

The measured value for each channel is represented in eight bits. This measured value corresponds to bits 15 ... 8 in the format representations of a 16-bit value.

Example: command 7000_{hex}

4 x 8-bit group A (channels 1, 2, 3, and 4)

IN0															
15	14	13	12	11	10	9	8	7	6	5	4	3	2	1	0
8-bit measured value channel 1 in the appropriate format								8-bit measured value channel 2 in the appropriate format							

IN1															
15	14	13	12	11	10	9	8	7	6	5	4	3	2	1	0
8-bit measured value channel 3 in the appropriate format								8-bit measured value channel 4 in the appropriate format							



The status bits in IB ST format and the diagnostic messages in IB IL format and standardized representation format are not displayed in this parameterization.

15.7 Supported error codes for IB IL and standardized representation formats

In IB IL and standardized representation format, a diagnostic code is mapped to the input data in the event of an error:

Code (hex)	Cause
8001	Measuring range exceeded (overrange)
8002	Open circuit
8004	Measured value invalid or no valid measured value available
8010	Configuration invalid
8020	Faulty supply voltage
8040	Device faulty
8080	Below measuring range (underrange)

16 Formats for representing measured values



Phoenix Contact recommends format IB IL for all controllers as this format contains the most comprehensive diagnostic codes.

The other formats are only intended for simplifying reconfiguration on IB IL analog modules in existing projects.

16.1 IB IL format

The measured value is represented in bits 14 to 0. An additional bit (bit 15) is available as a sign bit.

This format supports extended diagnostics. Values $> 8000_{\text{hex}}$ and $< 8100_{\text{hex}}$ indicate an error.

The error codes are specified in the section "Supported IB IL error codes and standardized representation".

Measured value representation in IB IL format

Bit	15	14	13	12	11	10	9	8	7	6	5	4	3	2	1	0
Assignment	V	Analog value														

V Sign bit

Significant measured values

Input data		0 V ... 5 V	0 V ... 10 V	0 V ... 25 V	0 V ... 50 V	±5 V	±10 V	±25 V
hex	dec	V	V	V	V	V	V	V
8001	Overrange	> +5.419	> +10.837	> +27.093	> +54.187	> +5.419	> +10.837	> +27.093
7F00	32512	+5.419	+10.837	+27.093	+54.187	+5.419	+10.837	+27.093
7530	30000	+5.0	+10.0	+25.0	+50.0	+5.0	+10.0	+25.0
0001	1	+166.67 μV	+333.33 μV	+833.33 μV	+1.6667 mV	+166.67 μV	+333.33 μV	+833.33 μV
0000	0	≤ 0	≤ 0	≤ 0	≤ 0	0	0	0
FFFF	-1					-166.67 μV	-333.33 μV	-833.33 μV
8AD0	-30000					-5.0	-10.0	-25.0
8100	-32512					-5.419	-10.837	-27.093
8080	Underrange					< -5.419	< -10.837	< -27.093

IB IL AI 8/SF(-2MBD)-PAC

Input data		0 mA ... 20 mA	0 mA ... 40 mA	4 mA ... 20 mA	±20 mA	±40 mA
hex	dec	mA	mA	mA	mA	mA
8001	Overrange	>+21.6746	> +43.3493	> +21.3397	>+21.6746	> +43.3493
7F00	32512	+21.6746	+43.3493	+21.3397	+21.6746	+43.3493
7530	30000	+20.0	+40.0	+20.0	+20.0	+40.0
0001	1	+0.66667 µA	+1.3333 µA	+4.0005333	+0.66667 µA	+1.3333 µA
0000	0	≤ 0	≤ 0	+4.0 ... +3.2	0	0
FFFF	-1				-0.66667 µA	-1.3333 µA
8AD0	-30000				-20.0	-40.0
8100	-32512				-21.6746	-43.3493
8080	Underrange				< -21.6746	< -43.3493
8002	Open circuit			< +3.2		

16.2 IB ST format

The measured value is represented in bits 14 to 3.

An additional bit (bit 15) is available as a sign bit.

Bits 2 to 0 are available as measuring range and error bits.

IB ST format corresponds to the data format used on INTERBUS ST modules.

Measured value representation in IB ST format

Bit	15	14	13	12	11	10	9	8	7	6	5	4	3	2	1	0
Assignment	V	Analog value												0/4	OC	BÜ

V	Sign bit
0/4	4 mA ... 20 mA measuring range
OC	Open circuit
BÜ	Overrange

Significant measured values

Input data		0 V ... 5 V	0 V ... 10 V	0 V ... 25 V	0 V ... 50 V	±5 V	±10 V	±25 V
hex	dec	V	V	V	V	V	V	V
7FF9	Overrange	> +5.375	> +10.75	> +26.875	> +53.75	> +5.375	> +10.75	> +26.875
7FF8	32760	+4.9988 ... +5.375	+9.9975 ... 10.75	+24.9939 ... +26.875	+49.9878 ... +53.75	+4.9988 ... +5.375	+9.9975 ... 10.75	+24.9939 ... +26.875
4000	16384	+2.5	+5.0	+12.5	+25.0	+2.5	+5.0	+12.5
0008	8	+0.001221	+0.002441	0.0061025	+0.012205	+0.001221	+0.002441	0.0061025
0000	0	≤ 0	≤ 0	≤ 0	≤ 0	0	0	0
FFF8	-8					-0.001221	-0.002441	-0.0061025
C000	-16384					-2.5	-5.0	-12.5
8000	-32768					-5.0 ... - 5.375	-10.0 ... - 10.75	-25.0 ... - 26.875
8001	-32767					< -5.375	> -10.75	< -26.875

Input data		0 mA ... 20 mA	0 mA ... 40 mA	±20 mA	±40 mA
hex	dec	mA	mA	mA	
7FF9	Overrange	> +21.5	> +43.0	> +21.5	> +43.0
7FF8	32760	+19.9951 ... +21.5	+39.9902 ... +43.0	+19.9951 ... +21.5	+39.9902 ... +43.0
4000	16384	+10.0	+20.0	+10.0	+20.0
0008	8	+0.0048828	+0.0097565	+0.0048828	+0.0097565
0000	0	≤ 0	≤ 0	0	0
FFF8	-8			-0.0048828	-0.0097565
8000	-32768			-20.0 ... -21.5	-40.0 ... -43.0
8001	-32767			< -21.5	< -43.0

IB IL AI 8/SF(-2MBD)-PAC

Input data		4 mA ... 20 mA
hex	dec	mA
7FFD	32765	> +21.5
7FFC	32764	+19.9961 ... +21.5
4000	16384	+10.0
000C	12	+4.003906
0004	4	+4.0 ... +3.2
0006	6	< +3.2

16.3 IB RT format

The measured value is represented in bits 14 to 0. An additional bit (bit 15) is available as a sign bit.

IB RT format corresponds to the data format used on INTERBUS RT modules.

Error codes and error bits are not defined in this data format. The positive final value $7FFF_{\text{hex}}$ indicates an open circuit.

Measured value representation in IB RT format

Bit	15	14	13	12	11	10	9	8	7	6	5	4	3	2	1	0
Assignment	V	Analog value														

V Sign bit

Significant measured values

Input data		0 mA ... 20 mA	0 mA ... 40 mA	±20 mA	±40 mA	4 mA ... 20 mA
hex	dec	mA	mA	mA	mA	
7FFF	32767	≥ +19.9993896	≥ +39.9987793	≥ +19.999385	≥ +39.9987793	≥ +19.9995117
7FFE	32766	≥ +19.9987793	+39.9975586	+19.998779	+39.9975586	+19.9990234
4000	16384	+10.0	+20.0	+10.0	+20.0	+12.0
0001	1	+0.6104 μA	+1.2207 μA	+0.6104 μA	+1.2207 μA	+4.0004884 μA
0000	0	≤ 0	≤ 0	0	0	+4.0 ... +3.2
FFFF	-1			-0.6104 μA	-1.2207 μA	
C000	-16384			-10.0	-20.0	
8001	-32767			-19.999385	-39.9987793	
8000	-32768			≤ -20.0	≤ -40.0	
7FFF	32767					< +3.2

Input data		0 V ... 5 V	0 V ... 10 V	0 V ... 25 V	0 V ... 50 V	±5 V	±10 V	±25 V
hex	dec	V	V	V	V	V	V	V
7FFF	32767	≥ +4.999847	≥ +9.999695	≥ +24.999237	≥ +49.998474	≥ +4.999847	≥ +9.999695	≥ +24.999237
7FFE	32766	+4.999695	+9.999390	+24.998474	+49.996948	+4.999695	+9.999390	+24.998474
4000	16384	+2.5	+5.0	+12.5	+25.0	+2.5	+5.0	+12.5
0001	1	+152.6 μV	+305.2 μV	+762.9 μV	+1.5259 mV	+152.6 μV	+305.2 μV	+762.9 μV
0000	0	≤ 0	≤ 0	≤ 0	≤ 0	0	0	0
FFFF	-1					-152.6 μV	-305.2 μV	-762.9 μV
C000	-16384					-2.5	-5.0	-12.5
8001	-32767					-4.999847	-9.999695	-24.999237
8000	-32768					≤ -5.0	≤ -10.0	≤ -25.0

16.4 Standardized representation format

The measured value is represented in bits 14 to 0. An additional bit (bit 15) is available as a sign bit.

In this format, data is standardized to the measuring range and represented in such a way that it indicates the corresponding value without conversion.

This format supports extended diagnostics. Values $> 8000_{\text{hex}}$ and $< 8100_{\text{hex}}$ indicate an error.

The error codes are specified in the section "Supported IB IL error codes and standardized representation".

In this format, one bit has the following validity for the measuring ranges stated:

Measuring range	Validity of one bit
0 V ... 5 V, ± 5 V	1 mV
0 V ... 10 V, ± 10 V	1 mV
0 V ... 25 V, ± 25 V	1 mV
0 V ... 50 V	10 mV
0 mA ... 20 mA, 4 mA ... 20 mA	1 μ A
0 mA ... 40 mA	10 μ A

Measured value representation in standardized representation format

Bit	15	14	13	12	11	10	9	8	7	6	5	4	3	2	1	0
Assignment	V	Analog value														

V Sign bit

Significant measured values



Due to the standardized representation not all of the possible codes are used. In addition, some codes are used for diagnostic functions. Therefore, the resolution is not 15 bits but exactly 13.287713 bits.

IB IL AI 8/SF(-2MBD)-PAC

Input data		0 V ... 5 V	0 V ... 10 V	0 V ... 25 V	0 V ... 50 V	±5 V	±10 V	±25 V
hex	dec	V	V	V	V	V	V	V
8001	Overrange	> +5.419	> +10.837	> +27.093	> +54.187	> +5.419	> +10.837	> +27.093
69D5	27093			+27.093				+27.093
61A8	25000			+25.0				+25.0
2A55	10837		+10.837				+10.837	
2710	10000		+10.0				+10.0	
152B	5419	+5.419			+54.187	+5.419		
1388	5000	+5.0	+5.0		+50.0	+5.0	+5.0	
0001	1	+0.001	+0.001	+0.001	+0.01	+0.001	+0.001	+0.001
0000	0	≤ 0	≤ 0	≤ 0	≤ 0	0	0	0
FFFF	-1					-0.001	-0.001	-0.001
EC78	-5000					-5.0	-5.0	
EAD5	-5419					-5.419		
D8F0	-10000						-10.0	
D5AB	-10837						-10.837	
AB56	-21674							
9E58	-25000							
962B	-27093							
8080	Underrange (input)					< -5.419		-27.093

Input data		0 mA ... 20 mA	0 mA ... 40 mA	± 20 mA	±40 mA	4 mA ... 20 mA
hex	dec	mA	mA	mA	mA	mA
8001	Overrange	> +21.674	> +43.3493	> +21.674	> +43.3493	> +21.339
54AA	21674	+21.674		+21.674		
4E20	20000	+20.0		+20.0		
43BB	17339		21.339		> +21.339	
3E80	16000					+20.0
2710	10000	+10.0	+14.0	+10.0		
1388	5000	+5.0	+9.0	+5.0		
10EE	4334		+43.3493		+43.3493	
0FA0	4000		+40.0		+40.0	
0001	1	+0.001	+0.01	+0.001	+0.01	+4.001
0000	0	≤ 0	≤ 0	0	0	+4.0 ... +3.2
FFFF	-1			-0.001	-0.01	
F060	-4000				-40.0	
EF12	-4334					
EC78	-5000			-5.0		
D8F0	-10000			-10.0		
B1E0	-20000			-20.0		
AB56	-21674					
8080	Underrange				< -43.349	< +3.2

16.5 Example

Measured value representation in different data formats

Measuring range 0 mA ... 20 mA
 Measured value 10 mA

Format	Value		Measured value
	hex	dec	
IB IL	3A98	15000	10 mA
IB ST	4000	16384	10 mA
IB RT	4000	16384	10 mA
Standardized representation	2710	10000	10 mA

Measuring range -10 V ... +10 V
 Measured value 5 V

Format	Value		Measured value
	hex	dec	
IB IL	3A98	15000	5 V
IB ST	4000	16384	5 V
IB RT	4000	16384	5 V
Standardized representation	2710	5000	5 V

16.6 PIO format

PIO format enables high-resolution representation of measured values in the 4 mA ... 20 mA current measuring range. In this format, a hypothetical measuring range of 0 mA ... 25 mA is divided into 2^{16} quantization steps (65,536 steps). This means that unipolar measured currents can be represented with a resolution of $0.38 \mu\text{A}/\text{LSB}$. Although this format is designed for the 4 mA ... 20 mA range, signals between 0 mA and 24 mA can be acquired so the overrange limits and the open-circuit threshold in the higher-level controller can be freely defined.

Measured value representation in PIO format

Bit	15	14	13	12	11	10	9	8	7	6	5	4	3	2	1	0
Assignment	Analog value															

Example of parameterization in PIO format

Channel	1
Filter	16-sample mean-value
Format	PIO
Measuring range	4 mA ... 20 mA

Option 1

Parameterize channel 1

OUT0 4000_{hex}

OUT1 004A_{hex}

Read measured value of channel 1

OUT0 0000_{hex}

OUT1 0000_{hex}

Option 2

Parameterize channel 1 and read measured value of channel 1

OUT0 5000_{hex}

OUT1 004A_{hex}

Significant measured values

Input data		4 mA ... 20 mA
dec	hex	mA
F5C2	62914	+24.0
CCCD	52429	+20.0
6666	26214	+10.0
0A3D	2621	1.0
0001	1	+0.3815 μA
0000	0	0

17 IN process data in the event of an error

In the event of an error, the command is mirrored in input word IN0 and the set error bit displays the error.

Input word IN1 indicates the error cause.

The following diagnostic codes are valid for parameterization errors and hardware faults in all data formats.

Command code hex	Diagnostic code hex	PF	Meaning	Corrective
	8020	X	Supply voltage faulty (I/O supply)	Check the supply voltage of the station head (e.g., U_{BK}) Check the potential jumper contacting.
After module start	8040	X	Device faulty	Replace terminal.
0x00	8004		There is no valid parameterization for the channel requested.	Parameterize channel.
5x00	8004		The parameterization just specified is invalid.	Check and correct parameterization.
4x00			The parameters are mirrored. This is usually caused by invalid parameters.	Check and correct parameters.
6000				
3C00			No diagnostic code.	

PF: a peripheral fault is reported to the higher-level controller.

In addition to the indication in the input words, for diagnostic codes 8040_{hex} (device faulty) and 8020_{hex} (supply voltage faulty), a peripheral fault is reported to the higher-level controller.



IB IL format and standardized representation format offer additional diagnostic functions.

18 Startup options

The following examples illustrate how to use the terminal.

18.1 Standard method 1

Task

All channels are to be operated in the same parameterization (command code 6000hex).

Parameter	Value	bin	dec
Filter	32-sample mean-value	11	3
Format	IB IL	000	0
Measuring range	±10 V	0001	1

Procedure

1. Install the terminal.
2. Connect the voltage (power up).
3. Parameterize the terminal. (Initialization phase, e.g., initialization phase of the application program)
4. Read the measured value for each channel in turn.

Initialization phase

The OUT process data looks like this according to the task:

OUT0																	
Bit	15	14	13	12	11	10	9	8	7	6	5	4	3	2	1	0	
Assignment	0	Command							0	0	0	0	0	0	0	0	0
bin	0	1	1	0	0	0	0	0	0	0	0	0	0	0	0	0	
hex	6				0				0				0				

OUT1																	
Bit	15	14	13	12	11	10	9	8	7	6	5	4	3	2	1	0	
Assignment	0	0	0	0	0	0	Filter		0	Format			Measuring range				
bin	0	0	0	0	0	0	1	1	0	0	0	0	0	0	0	1	
hex	0				3				0								

With the command in OUT0, the parameterization according to OUT1 is sent to the module electronics. When parameterization is completed, the command and parameterization are mirrored in the IN process data.

Parameterize terminal	OUT0	6000 _{hex}	OUT1	0301 _{hex}
Parameterization completed successfully	IN0	6000 _{hex}	IN1	0301 _{hex}
Error during parameterization	IN0	E000 _{hex}	IN1	0301 _{hex}

A cyclic program sequence, which reads the measured values of the individual channels, takes place after parameterization has been completed successfully.

Appearance of output data word OUT0:

OUT0																
Bit	15	14	13	12	11	10	9	8	7	6	5	4	3	2	1	0
Assignment	0	Command							0	0	0	0	0	0	0	0
bin	0	0	0	0	0	K	K	K	0	0	0	0	0	0	0	1
hex	0				x				0				0			

Command 0x00_{hex} does not require any parameters and the value of parameter word OUT1 is 0000_{hex}.

IB IL AI 8/SF(-2MBD)-PAC

With the command in OUT0, the read request is sent to the module electronics. After the command has been executed, it is mirrored in process data input word IN0 and the analog value (xxxx_{hex}) or a diagnostic message (yyyy_{hex}) is displayed in process data input word IN1.

Read measured value of channel 1	OUT0	0000_{hex}	OUT1	0000_{hex}
Parameterization completed successfully	IN0	0000 _{hex}	IN1	xxxx _{hex}
Error during execution	IN0	8000 _{hex}	IN1	yyyy _{hex}
Read measured value of channel 2	OUT0	0100_{hex}	OUT1	0000_{hex}
Parameterization completed successfully	IN0	0100 _{hex}	IN1	xxxx _{hex}
Error during execution	IN0	8100 _{hex}	IN1	yyyy _{hex}
Read measured value of channel 8	OUT0	0700_{hex}	OUT1	0000_{hex}
Parameterization completed successfully	IN0	0700 _{hex}	IN1	xxxx _{hex}
Error during execution	IN0	8700 _{hex}	IN1	yyyy _{hex}

18.2 Standard method 2

Task:

All channels are to be operated in different parameterizations.

The channels are to be parameterized first (4x00_{hex}). After parameterization, the measured values are to be read (0x00_{hex}).

Configuration of the channels:

Parameter	Channel 1	Channel 2	Channel 3	...
Filter	No filter	16-sample mean-value	4-sample mean-value	...
bin/dez	01/1	00/0	10/2	
Format	IB IL	IB IL	IB IL	
bin/dez	000/0	000/0	000/0	
Measuring range	0 V ... 50 V	0 V ... 5 V	4 mA ... 20 mA	
bin/dez	0110/6	0010/2	1010/10	

Procedure

1. Install the terminal.
2. Connect the voltage (power up).
3. Parameterize each channel of the terminal in turn. (Initialization phase, e.g., initialization phase of the application program)
4. Read the measured value for each channel in turn.

Initialization phase

OUT0 for all channels:

	OUT0																
Bit	15	14	13	12	11	10	9	8	7	6	5	4	3	2	1	0	
Assignment	0	Command							0	0	0	0	0	0	0	0	0
bin	0	1	0	0	0	K	K	K	0	0	0	0	0	0	0	0	
hex	4				x				0				0				

OUT1 indicates the parameters for each channel according to the task. For channel 1, it looks like this:

	OUT1															
Bit	15	14	13	12	11	10	9	8	7	6	5	4	3	2	1	0
Assignment	0	0	0	0	0	0	Filter		0	Format			Measuring range			
bin	0	0	0	0	0	0	0	1	0	0	0	0	0	0	0	1
hex	0				1				0				0			

With the command in OUT0, the parameterization according to OUT1 is sent to the module electronics for each channel. When parameterization of a channel is completed, the command and parameterization are mirrored in the IN process data.

IB IL AI 8/SF(-2MBD)-PAC

Parameterize channel 1	OUT0	4000_{hex}	OUT1	0106_{hex}
Parameterization completed successfully	IN0	4000 _{hex}	IN1	0106 _{hex}
Error during parameterization	IN0	C000 _{hex}	IN1	0106 _{hex}
Parameterize channel 2	OUT0	4100_{hex}	OUT1	0002_{hex}
Parameterization completed successfully	IN0	4100 _{hex}	IN1	0002 _{hex}
Error during parameterization	IN0	C100 _{hex}	IN1	0002 _{hex}
Parameterize channel 3	OUT0	4200_{hex}	OUT1	020A_{hex}
Parameterization completed successfully	IN0	4200 _{hex}	IN1	020A _{hex}
Error during parameterization	IN0	C200 _{hex}	IN1	020A _{hex}

Parameterize channels 4 to 8 accordingly.

A cyclic program sequence, which reads the measured values of the individual channels, takes place after parameterization has been completed successfully.

Appearance of output data word OUT0:

	OUT0																
Bit	15	14	13	12	11	10	9	8	7	6	5	4	3	2	1	0	
Assignment	0	Command							0	0	0	0	0	0	0	0	0
bin	0	0	0	0	0	K	K	K	0	0	0	0	0	0	0	1	
hex	0				x				0				0				

Command 0x00_{hex} does not require any parameters and the value of parameter word OUT1 is 0000_{hex}.

With the command in OUT0, the read request is sent to the module electronics. After the command has been executed, it is mirrored in process data input word IN0 and the analog value (xxxx_{hex}) or a diagnostic message (yyyy_{hex}) is displayed in process data input word IN1.

The appearance of the input and output words is the same as in standard method 1.

18.3 Special methods

The group commands are considered special methods.

Task

The measured values of channels 1 to 4 (group A) are to be read in one cycle and the measured values of channels 5 to 8 (group B) in another cycle (7000_{hex} for group A, 7100_{hex} for group B).

The input channels are to be operated in different parameterizations (e.g., as in standard method 2).

Procedure

1. Install the terminal.
2. Connect the voltage (power up).
3. Parameterize each channel of the terminal in turn. (Initialization phase, e.g., initialization phase of the application program)
As the channels need to be parameterized differently, use command 4x00_{hex}.
4. Use group command 7000_{hex} to read the measured values for channels 1 to 4 simultaneously. Then use group command 7100_{hex} to read the measured values for channels 5 to 8.
Both groups can be reread cyclically.

Advantages of the standard methods compared to the special methods

- The standard methods read the measured values with greater reliability because the command is mirrored for every measured value. You can therefore precisely identify the channel that supplied the measured value.
- The standard methods enable more accurate error diagnostics than the special methods.
- If you switch the group command for reading the channels (e.g., between 7000_{hex} and 7100_{hex} when reading two groups of four channels each), you must allow sufficient time to do so.
You must make sure that the received measured values belong to the requested group. This can only be ensured using waiting times.

19 Application notes

19.1 Precision DC measurements

Precision DC measurements constitute an optimum area of application for the terminal. The high-resolution analog-to-digital converter and excellent instrumentation amplifier technology achieve a very high level of accuracy (typically 0.02% in the voltage range).

In order to take full advantage of these features, the following parameterizations are recommended:

Measured value acquisition	Standard method 1 or 2
Format	IB IL
Filter	32-sample mean-value

This suppresses undesirable interference signals and provides a low-noise, accurate measured result. Non-time-critical, i.e., slow processes are a prerequisite for this application.

19.2 Closed-loop control tasks

The terminal makes closed-loop control tasks particularly easy to implement. In INTERBUS networks, the terminal supports the advantages with regard to time equidistance. As the terminal samples input signals synchronously with the bus clock and the bus runtime has a very small jitter, the input signals can be sampled equidistantly. The measured results are therefore particularly suitable for use in closed-loop control.

The following parameterizations and measures are recommended:

Measured value acquisition	Standard method 1 or 2 In special cases, the group commands (7x00 _{hex}) can be an exception.
Filter	No filter As total accuracy is often irrelevant in closed-loop control tasks, filtering is not necessary. This increases the dynamic response of the terminal and speeds up the closed-loop control circuit.
Cycle time in the local bus	Adjust the cycle time in the local bus to the firmware runtime. Example for INTERBUS: in standard method 1, the firmware runtime is < 800 μ s, i.e., you should set the INTERBUS cycle time to 800 μ s here.

In applications in which an 8-bit resolution is sufficient, you can use group commands 7000_{hex} and 7100_{hex} to read four channels simultaneously. Here too sampling is synchronous with the bus clock. Four channels require < 1500 μ s.

19.3 Signal sampling or fast, sudden signals

The terminal is ideal for sampling signals. As a result of the high input limit frequency (3.5 kHz), there are no limiting elements in the analog stage. The maximum signal frequency that can be sampled depends on the firmware runtime and the INTERBUS cycle time.

The terminal measuring device can measure signals with a frequency of $1/800 \mu\text{s} = 1.25 \text{ kHz}$. According to Shannon's sampling theorem, therefore, the signal frequency that can be sampled is $1.25 \text{ kHz} / 2 = 0.625 \text{ kHz}$.

The following parameterizations and measures are recommended:

Measured value acquisition	Standard method 1 or 2
Filter	No filter This increases the dynamic response of the terminal.
Cycle time in the local bus	Adjust the cycle time in the local bus to the firmware runtime. This achieves discrete periods of sampling. Example for INTERBUS: in standard method 1, the firmware runtime is < 800 μ s, i.e., you should set the INTERBUS cycle time to 800 μ s here.

19.4 Linked voltages

When using linked voltages, ensure that the terminal has eight single-ended inputs. A common ground potential should therefore be used with linked voltages. As the terminal has many measuring ranges, for example the 0 V ... 50 V range, and the resolution is high enough, applications with several linked voltages can also be implemented without any problems.

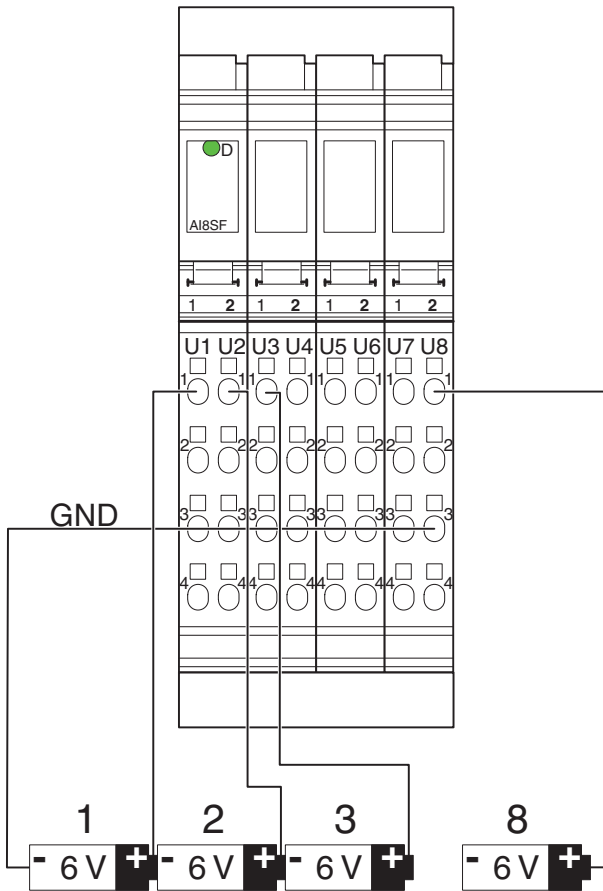

Figure 6 Measuring linked voltages

19.5 Current loops

If the terminal is used to measure currents in current loops, make sure that the eight current inputs operate on a common ground potential (single-ended). The measuring input should therefore always be on the GND potential with the minus input.

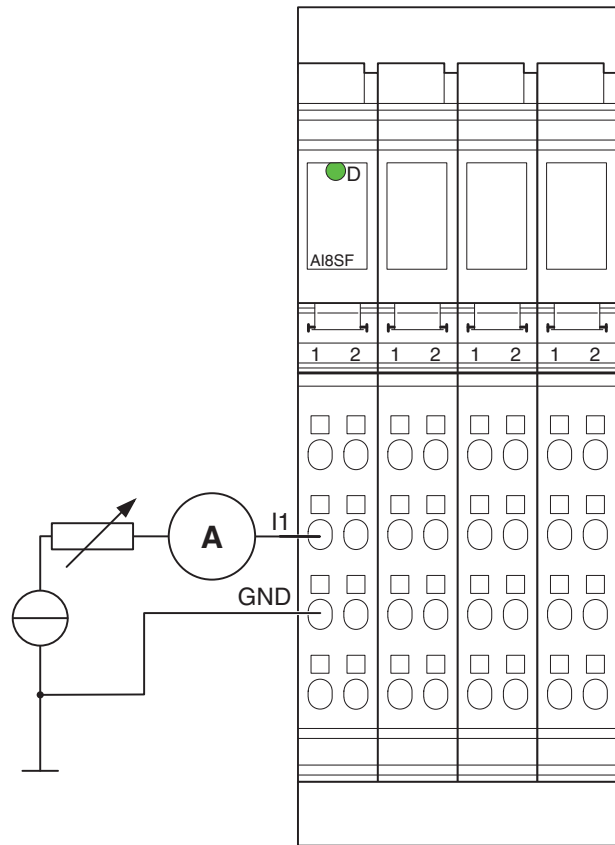

Figure 7 Measuring currents



SCATTERGOOD & JOHNSON LTD

ELECTRICAL ENGINEERING & FLUID CONTROL DISTRIBUTORS

Est.1899

At Scattergood & Johnson Ltd, we pride ourselves on being a technical distributor to specialist industries.

Working with a range of quality product suppliers across a number of specialist markets, we are not your average 'box shifter' - we are your technical and supply chain partner.

We fully support every product we sell - for free! Our internal team and external sales engineers can answer any product or application question, no matter the complexity.

Backing up this technical ability is a range of 50,000+ products available from stock for nationwide next day delivery (same day if required!), or you can collect what you need from any of our trade counters around the UK.

Select your specialist interest below to learn more about how we can help.

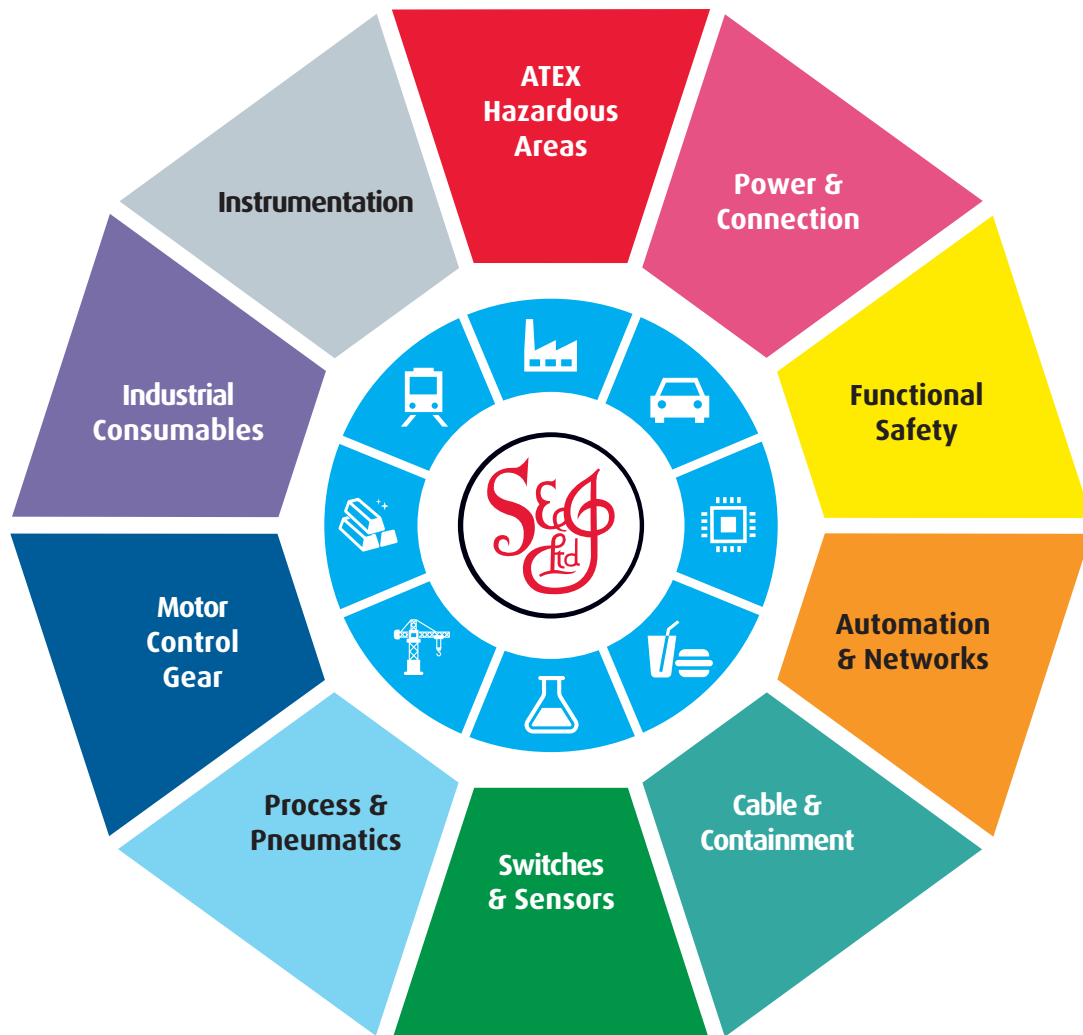

Online, In Branch and On the Road - Scattergood & Johnson Ltd, there when you need us.

www.scatts.co.uk