

IB IL INC-IN(-2MBD)-PAC

**Inline measurement terminal for position encoder,
1 input for incremental encoder with rectangular
signal, 3 digital inputs 24 V DC**

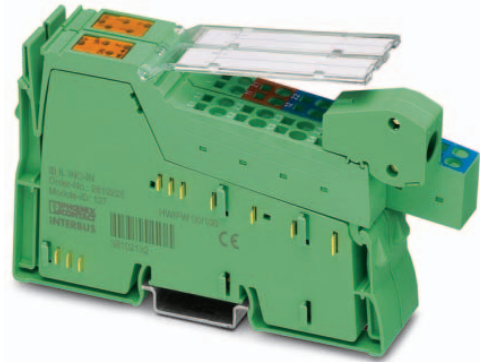

Data sheet
6390_en_09

© PHOENIX CONTACT 01/2016

1 Description

The terminal for incremental encoders is used to determine positions (lengths) or angular positions with relatively operating encoder systems, i.e., it reads position or angular information from incremental encoders with square-wave signals.

Both symmetrical encoders (RS-422) and asymmetrical encoders (5 V DC to 24 V DC) with square-wave signals can be connected to the terminal. Rotary encoders or length measuring systems with or without Z pulse can be read.

In order to increase the operational reliability all encoder inputs are monitored for cable breaks. Using a special operating mode, the terminal supports distance encoded incremental encoders, which enable homing to be reduced to very small distances.

In addition to the input for the encoder signals, the terminal also has three digital 24 V DC inputs, one input for the home position switch, and two inputs for limit switches. Thus 2 or 3-wire sensors can be connected. Input I3 can also be used as an "open collector" output.

The terminal records the position values using a counter, which counts up or down depending on the phase angle of the A and B signals.

Features

- Three inputs for home position switch inputs or limit switch inputs
- Encoder support with symmetrical signal lines according to the RS-422 EIA standard (line-driver output)
- Encoder support with asymmetrical signal lines (push-pull)
- Distance encoded incremental encoder
- Encoder with 5 V or 24 V voltage supply
- Linear encoder
- Rotary encoders
- Diagnostic and status indicators



This data sheet is only valid in association with the IL SYS INST UM E user manual.



Make sure you always use the latest documentation.
It can be downloaded at phoenixcontact.net/download.



This data sheet is valid for the products listed on page 3.

Table of contents

1	Description.....	1
2	Ordering data.....	3
3	Technical data	3
4	Basic circuit diagram.....	7
	5.1 Terminal point assignment of the shield connector (1)	8
	5.2 Terminal point assignment of the connector (2).....	8
6	Connection examples	9
	6.1 Symmetrical encoders.....	9
	6.2 Asymmetrical encoders.....	9
7	Connection notes.....	10
8	Local diagnostic and status indicators	11
	9.1 Peripheral fault	12
	9.2 Position detection.....	13
	9.3 Homing for distance-encoded linear encoders.....	14
10	Process data words	16
	10.1 IN process data words.....	16
	10.2 Error/message code.....	16
	10.3 OUT process data words.....	17
	10.4 Control codes for selecting the evaluation and encoder type	17
	10.5 Control codes for selecting the operating mode	18

2 Ordering data

Description	Type	Order No.	Pcs. / Pkt.
Inline measurement terminal for position encoder, complete with accessories (connector and labeling field), 1 input for incremental encoder with rectangular signal (symmetrical or asymmetrical), 3 digital inputs 24 V DC, 3-conductor connection system	IB IL INC-IN-PAC	2861755	1
Inline measurement terminal for position encoder, complete with accessories, 1 input for incremental encoder with rectangular signal (symmetrical or asymmetrical), 3 digital inputs 24 V DC, 3-conductor connection method, transmission speed 2 Mbaud	IB IL INC-IN-2MBD-PAC	2819765	1

Accessories	Type	Order No.	Pcs. / Pkt.
Connector, color coded, for digital 4, or 16-channel Inline input terminals (Connector/Adapter)	IB IL SCN-12-ICP	2727611	10
Inline shield connector (Connector/Adapter)	IB IL SCN-6 SHIELD	2726353	5
Labeling field, width: 12.2 mm (Marking)	IB IL FIELD 2	2727501	10
Insert strip, Sheet, white, unlabeled, can be labeled with: Office printing systems, Plotter: Laser printer, Mounting type: Insert, Lettering field: 62 x 10 mm (Marking)	ESL 62X10	0809492	1

Documentation	Type	Order No.	Pcs. / Pkt.
User manual, English, Automation terminals of the Inline product range	IL SYS INST UM E	-	-

3 Technical data

Dimensions (nominal sizes in mm)

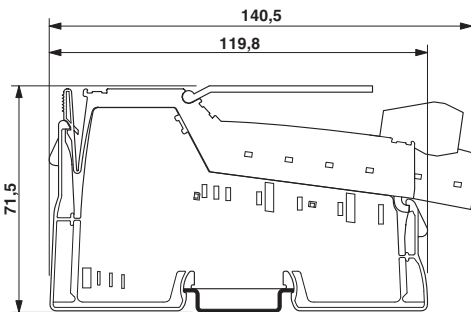

Width	24.4 mm
Height	140.5 mm
Depth	71.5 mm

General data

Color	green
Weight	143 g (with connectors)
Operating mode	Process data mode with 2 words
Connection method for sensors	2 or 3-wire technology
Connection method for actuators	2-wire technology, single-ended

General data (continued)

Permissible temperature (operation)	-25°C ... +55°C
Permissible temperature (storage/transport)	-25°C ... +85°C
Permissible humidity (operation/storage/transport)	10% to 95%, according to EN 61131-2
Permissible air pressure (operation/storage/transport)	70 kPa to 106 kPa (up to 3000 m above sea level)
Degree of protection	IP20 according to IEC 60529
Protection class	Class 3 according to EN 61131-2, IEC 611312-2

Connection data

Designation	Inline connector
Connection method	Spring-cage connection
Conductor cross section solid / stranded	0.08 mm ² ... 1.5 mm ² / 0.08 mm ² ... 1.5 mm ²
Conductor cross section [AWG]	28 ... 16
Stripping length	8 mm

Connection data for UL approvals

Designation	Inline connector
Connection method	Spring-cage connection
Conductor cross section solid / stranded	0.2 mm ² ... 1.5 mm ² / 0.2 mm ² ... 1.5 mm ²
Conductor cross section [AWG]	24 ... 16
Stripping length	8 mm

Interface

Local bus	Inline data jumper
-----------	--------------------

Transmission speed

IB IL INC-IN-PAC	500 kbps
IB IL INC-IN-2MBD-PAC	2 Mbps

Power consumption

	500 kbps	2 Mbps
Communications power U_L	7.5 V	7.5 V
Current consumption from U_L	70 mA, maximum	80 mA, maximum
Power consumption from U_L	525 mW	600 mW
I/O supply from U_M	24 V DC, typical	24 V DC, typical
Current consumption from U_M	1 A, maximum 340 mA, typical	1 A, maximum 340 mA, typical

Supply of the module electronics and I/O through bus coupler/power terminal

Connection method	Through potential routing
-------------------	---------------------------

Power dissipation

Power dissipation of the housing P_{HOu}	1.4 W, maximum (within the permissible operating temperature)
--	---

Digital inputs

Number	3
Input design	According to EN 661131-2, type 1
Definition of switching thresholds	
Signal range low	-30 V DC ... +5 V DC
Signal range high	15 V DC ... 30 V DC
Common potentials	I/O supply, ground
Nominal input voltage U_{IN}	24 V DC
Permissible range	-30 V < U_{IN} < +30 V DC

Digital inputs (continued)

Nominal input current for U_{IN}	2.7 mA, typical
Delay time	< 1 ms
Permissible cable length to the sensor	< 30 m (to ensure conformance with EMC directive)

Digital outputs

Number	1 (double assignment of input I3)
Output type	NPN (connected to ground)
Nominal residual voltage U_{OUT}	0.25 V DC
Nominal input current I_{NOM}	0.5 A
Tolerance of the nominal current	+10%

Incremental encoder inputs

Number	1
Encoder signal	Two pulse trains (A and B, electrically shifted by 90°) and one reference signal (Z)
Signal connection method	Shielded cables

**NOTE:**

Unshielded cables may lead to erroneous results in environments with heavy noise.

Encoder types**Symmetrical incremental encoders**

Signal	5 V DC (symmetrical pulse train (RS-422) with transversal track)
Encoder supply	5 V DC or 24 V DC
Signal connection method	A and \bar{A} , B and \bar{B} , Z and \bar{Z}
Signal voltage level	Differential signal (signal – inverted signal) ± 0.5 V, minimum; ± 6.0 V, maximum
Common mode range: signal – ground	-10 V ... +13.2 V
Input frequency	Up to 300 kHz
Cable length (for shielded cable)	< 30 m (to ensure conformance with EMC directive)

Asymmetrical incremental encoders

Signal	5 V DC ... 24 V DC (asymmetrical pulse train without transversal track)
Encoder supply	5 V DC or 24 V DC
Signal connection method	A, B, Z
Signal voltage level	Low ≤ 2.5 V, high ≥ 3.5 V (27 V, maximum)
Input frequency	Up to 300 kHz
Cable length (for shielded cable)	< 30 m (to ensure conformance with EMC directive)

Encoder supply**5 V encoder supply**

Voltage range	4.75 V ... 5.25 V
Short-circuit protection	Electronic and thermal
Current carrying capacity	250 mA, maximum

24 V encoder supply

Voltage range	19.2 V ... 30 V
Short-circuit protection	Electronic and thermal
Current carrying capacity	250 mA, maximum



The state of the encoder supplies (5 V/24 V) is indicated via two LEDs. If the internal voltage for the encoder electronics fails or is overloaded, an I/O error is generated. This error is indicated by the diagnostic LED flashing at 2 Hz and transmitted to the controller board.

Programming data (INTERBUS, local bus)

ID code (hex)	7F
ID code (dec.)	127
Length code (hex)	02
Length code (dec.)	02
Process data channel	32 Bit
Input address area	4 Byte
Output address area	4 Byte
Parameter channel (PCP)	0 Byte
Register length (bus)	4 Byte

Configuration and parameter data in a PROFIBUS system

Required parameter data	1 Byte
Need for configuration data	5 Byte

Error messages to the higher-level control or computer system

Failure or overload of the encoder supply	Yes, I/O error message sent to the controller board
No encoder connected	Yes, I/O error message sent to the controller board
Wire break on an encoder cable	Yes, I/O error message sent to the controller board

Electrical isolation/isolation of the voltage areas

Electrical isolation of the logic level from the I/O area is ensured through the optocoupler.

Common potentials

The 24 V main voltage, 24 V segment voltage, and GND have the same potential. FE is a separate potential area.

Separate potentials in the system consisting of bus coupler/power terminal and I/O terminal

Test distance	Test voltage
7.5 V supply (bus logic)/ I/O	500 V AC, 50 Hz, 1 min.
7.5 V supply (bus logic)/functional earth ground	500 V AC, 50 Hz, 1 min.
24 V supply (I/O)/functional earth ground	500 V AC, 50 Hz, 1 min.

Conformance with EMC directive 2004/108/EC**Noise immunity test according to EN 61000-6-2**

Electrostatic discharge (ESD)	EN 61000-4-2/IEC 61000-4-2	Criterion B 6 kV contact discharge 8 kV air discharge
Electromagnetic fields	EN 61000-4-3/IEC 61000-4-3	Criterion B Field strength: 10 V/m
Fast transients (burst)	EN 61000-4-4/IEC 61000-4-4	Criterion B Supply lines: 2 kV Signal/data lines: 2 kV
Conducted interference	EN 61000-4-6/IEC 61000-4-6	Criterion A Test voltage 10 V
Noise emission of housing	EN 55011	Class A

Approvals

For the latest approvals, please visit phoenixcontact.net/products.

4 Basic circuit diagram

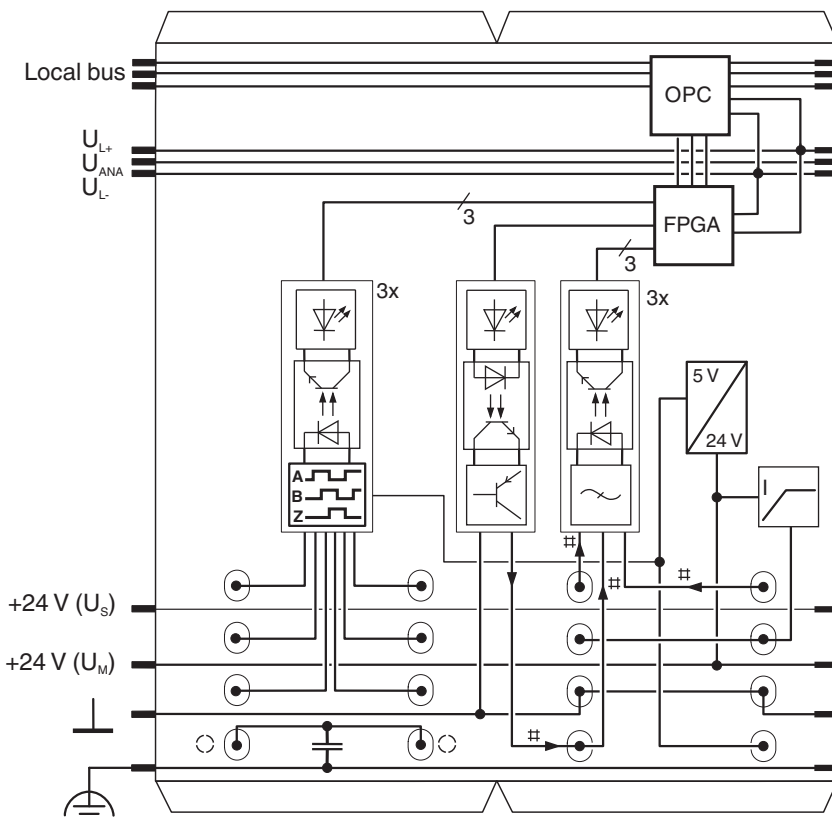













Figure 1 Internal wiring of the terminal points

Key:

	Protocol chip (bus logic including voltage conditioning)		Transistor
	Field-programmable gate array		Filter
	LED with function information		Encoder supply with short-circuit protection
	Optocoupler		Input
	Power supply unit		Coupling capacitor
	Receiver for encoder signals		Output

5 Terminal point assignment

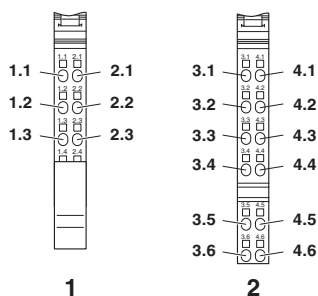

Figure 2 Inline terminal with appropriate connectors

5.1 Terminal point assignment of the shield connector (1)

Terminal point	Signal	Assignment	
		Symmetrical encoder	Asymmetrical encoder
1.1	A	Channel A	Channel A
2.1	/A	Channel A inverted	–
1.2	B	Channel B	Channel B
2.2	/B	Channel B inverted	–
1.3	Z	Channel Z	Channel Z
2.3	/Z	Channel Z inverted	–
1.4, 2.4	Shield	Encoder cable shield	Encoder cable shield



If a symmetrical encoder without Z signal is used, input Z must be jumpered to 0 V (GND) and input \bar{Z} must be jumpered to +5 V.

If an asymmetrical encoder is used, input Z must be jumpered to 0 V (GND) and input \bar{Z} remains open.

5.2 Terminal point assignment of the connector (2)

Terminal point	Signal	Assignment
3.1	E1	Input of limit switch 1
4.1	E2	Input of limit switch 2
3.2, 4.2	24 V	24 V encoder/limit switch supply
3.3, 4.3	GND	0 V encoder/limit switch supply
3.4	E3	Input for homing position switch or NPN output
4.4	5 V	5 V encoder/limit switch supply
3.5, 4.5	24 V	24 V encoder/limit switch supply
3.6, 4.6	GND	0 V encoder/limit switch supply

6 Connection examples

6.1 Symmetrical encoders

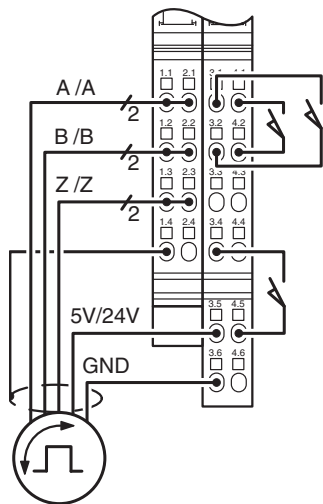

Figure 3 Typical connection with 24 V DC encoder supply

Key



Encoder/incremental encoder

6.2 Asymmetrical encoders

i Encoders with push/pull outputs are recommended for an error-free operation, in particular when the encoder or the cables to the encoder are located in an area with electromagnetic interference.

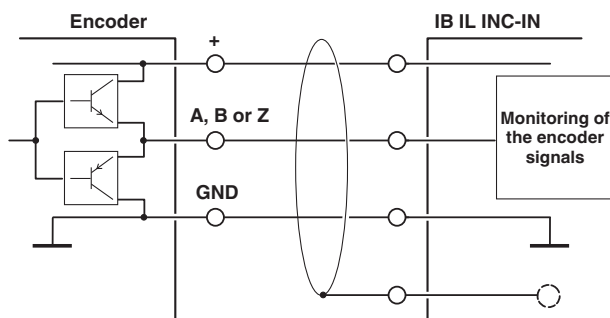

6390B011

Figure 4 Connection of asymmetrical encoders with push/pull outputs

i **When using encoders with NPN and open-collector (OC) outputs:**
 Apply every encoder signal with a pull-up resistor (R1) to "+".
 Size the resistor in line with the maximum permissible collector/emitter current of the encoder!
 Consider the resulting power dissipation when selecting resistor R1!

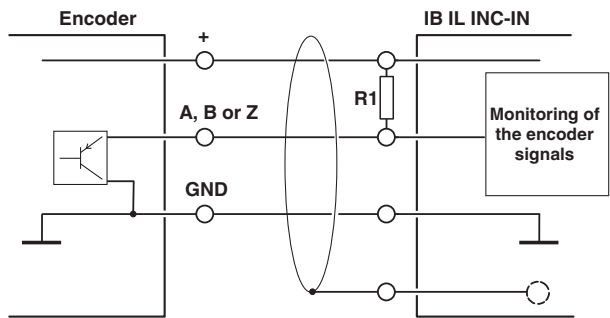

6390A020

Bild 5 Connection of asymmetrical encoders with NPN and OC outputs

7 Connection notes



Encoders should always be connected using **shielded** twisted pair cables. Unshielded cables may lead to erroneous results in environments with heavy noise. On the terminal side, the shield is capacitively connected to functional earth ground (FE) via the shield connector. On the encoder side, the shield must be connected with the grounded encoder housing.

If the encoder does not have a shield connection, the shield can also be directly connected in the control cabinet to functional earth ground via an additional shield connection clamp.



For information on shielding and connecting shielded cables, please refer to the IL SYS INST UM E user manual or the Inline system manual for your bus system.



Please also observe the manufacturer's installation instructions for the incremental encoder.

8 Local diagnostic and status indicators

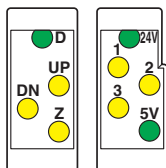

Figure 6 Local diagnostic and status indicators

Des.	Color	Meaning	
D	Green LED	Bus diagnostics	
	ON:	Bus active	
	Flashing:		
	0.5 Hz:	Communications power present, bus not active	
	2 Hz:	Communications power present, bus active, I/O error	
	4 Hz:	Communications power present, terminal before the flashing module failed, terminal after the flashing module not part of the configuration frame	
OFF:	Communications power present, bus not active		
UP	Yellow LED	Positive direction of rotation	
	ON and "DN" LED OFF:	Module counting upwards	
	OFF and "DN" LED OFF:	Standstill	
DN	Yellow LED	Negative direction of rotation	
	ON and "UP" LED OFF:	Module counting downwards	
	OFF and "UP" LED OFF:	Standstill	
Z	Yellow LED	Z signal	In incremental encoders the encoder is set to Z signal.
	ON:	Z signal present	
	OFF:	Z signal not active	In absolute encoders the LED flashes or is permanently on (depending on the speed).
24V	Green LED	24 V encoder supply	
	ON:	24 V encoder supply present	
	OFF:	24 V encoder supply not present	

Des.	Color	Meaning
1, 2, 3	Yellow LED	Inputs
	ON:	The corresponding input is set
	OFF:	The corresponding input is not set
5V	Green LED	5 V encoder supply
	ON:	5 V encoder supply present
	OFF:	5 V encoder supply not present

Function identification

Orange

2 Mbps: 2 Mbps: White stripe in the vicinity of the D LED

9 Function description

The terminal has been developed for use in an Inline station. It is used to read position and angular information.

Symmetrical or asymmetrical encoders can be connected for this.

The evaluating logic of the terminal detects the direction of rotation of the encoder using the pulse train and counts the pulses accordingly.

The data width in the bus system is 32 bits. The IN register has seven bits available for status indicators and messages and 25 bits available for actual position values. The OUT register has seven bits available for control commands and 25 bits available for setting the reference point value (see "Process data words" on page 16).

9.1 Peripheral fault

The terminal has the following monitoring mechanisms, which generate an I/O error message:

- Monitoring the encoder power supply (5 V or 24 V)
If the encoder supply fails or is overloaded, an I/O error is triggered and a corresponding message code is generated.
- Monitoring the encoder signals
The differential signal of a symmetrical encoder must be greater than 0.5 V.
An asymmetrical encoder must actively set the inputs, biased at 3 V using resistors, below 2.5 V (0-level) or above 3.5 V (1-level).
If these conditions are not met, an I/O error is triggered and a corresponding message code is generated.
These errors are caused by no encoder being connected, an asymmetrical encoder not being parameterized as an asymmetrical encoder or a wire break in an encoder cable.

9.2 Position detection

In order to start position detection after switching on the terminal, the control bits for the encoder type and the evaluation of OUT process data word OUT[0] are written to the terminal. The terminal then starts position detection with a random value in the positioning counter. As long as operating mode 0 ("Read actual position value") is not exited the actual position value only gives relative position values (without homing).

The control bits for the encoder type and evaluation must remain set as long as position detection is carried out. Changing the evaluation also requires new homing.

The terminal can only output an absolute position value if homing has been carried out on the terminal before. The homing function is used to set the positioning counter to the reference point value determined by OUT process data word OUT[0] on a specific point of an axis.

This homing process can be carried out by setting the reference point via the local bus (operating mode 1). During this process, the axis remains as still as possible or moves so slowly that the time delay, with which the signals are transmitted via the local bus, does not cause any major deviations.

Dynamic homing is also possible. In many applications, a higher level of precision is achieved through dynamic homing using a homing process.

The terminal provides five different types of homing (operating modes 2 to 6) for dynamic homing. The terminal responds directly to the connected limit switch or home position switch signals or the Z signal (index pulse from the encoder) with a hardware circuit.

Homing function sequence:

1. Start homing
The reference point value is written to OUT[0] and OUT[1]. Next, homing is started by means of writing one of the control codes for operating modes 1 to 5 to OUT[0].
If the terminal has been homed the message code switches to "Device not homed".
2. Wait for acknowledgment (status bit A)
The time it takes to receive acknowledgment varies depending on the homing mode. In operating mode 1, the acknowledgment bit (status bit A) appears immediately, in operating modes 2 to 6 the time it takes depends on the distance to the reference point and the speed at which the axis runs during homing (see page 16).
The "Homed" acknowledgment bit is present until an error occurs or a new homing process is initialized.
3. Read adjustment value (only for the homing types in operating modes 4 and 5)
In operating modes 4 and 5, the delta value (adjustment value) can be read in the "Actual position value" data field. This value indicates the distance between the position of the home position switch edge and the position of the Z pulse.
This value is present in the "Actual position value" data field until switching to operating mode 0 ("Read actual position value"). Beginning from the Z pulse position the positioning counter internally starts position detection.
4. Switch back to "Read actual position value"
Operating mode 0 ("Read actual position value") is selected in OUT[0]. The relevant positions can be read from the "Actual position value" data field in IN[0] and IN[1] (value range 0 to $2^{25} \dots 1$).

9.3 Homing for distance-encoded linear encoders

In addition to the counting tracks, distance encoded linear encoders are provided with a reference mark track with different increments. This results in fields between two reference marks, which differ in size. Each field only appears once in the linear system.

In order to detect the absolute position in the system only two reference marks must be overrun.

The process is carried out as follows (see Figure 7 and Figure 8): The slide position is unknown. In set operating mode 6 "110_{bin}" the slide is moved in any direction. When the slide reaches the first reference mark (Z) the internal counter is set to zero and the incoming increments of the counting track are added.

When the slide reaches the second reference mark the counter status determined between the two reference marks is output and the internal counter is set to zero again. At the same time, the "Acknowledgment, device homed" message code is output.

The output counter state corresponds to the increments of the overrun field and is present until switching to operating mode 0 "000_{bin}" ("Read actual position value"). After changing the operating mode, the counter state is displayed beginning from the second reference mark. The position corresponds to the position before or after the determined field depending on the counting and positioning directions.

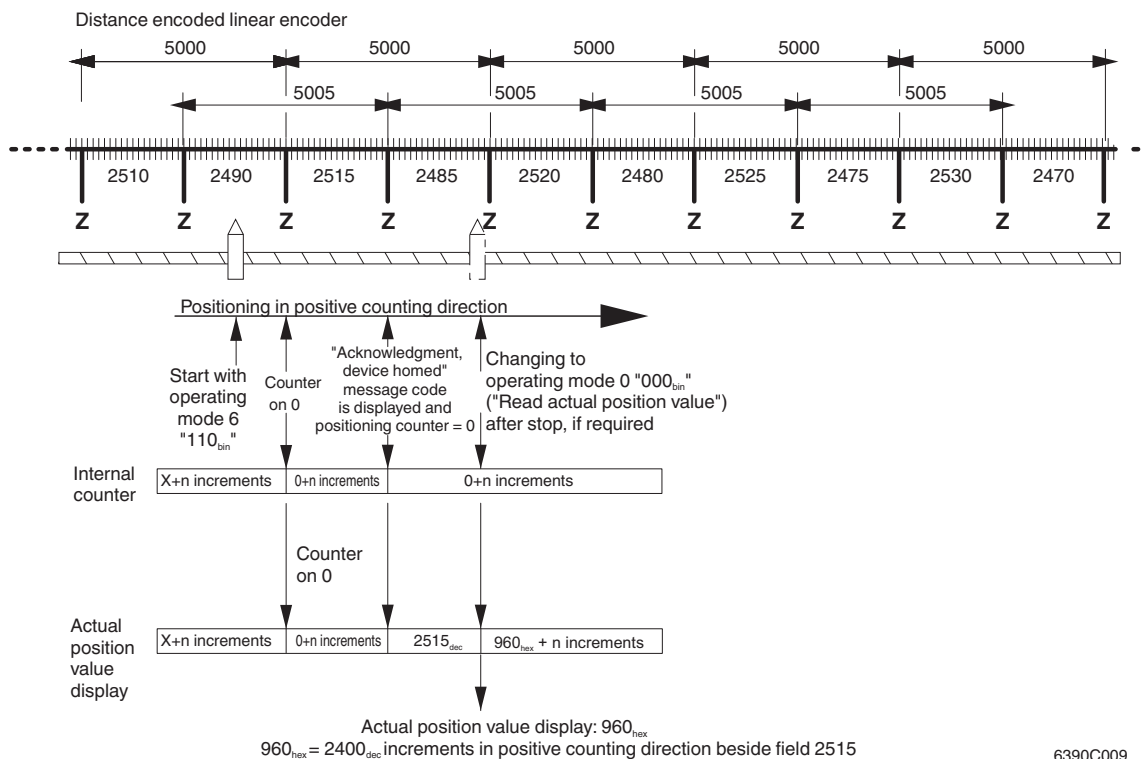
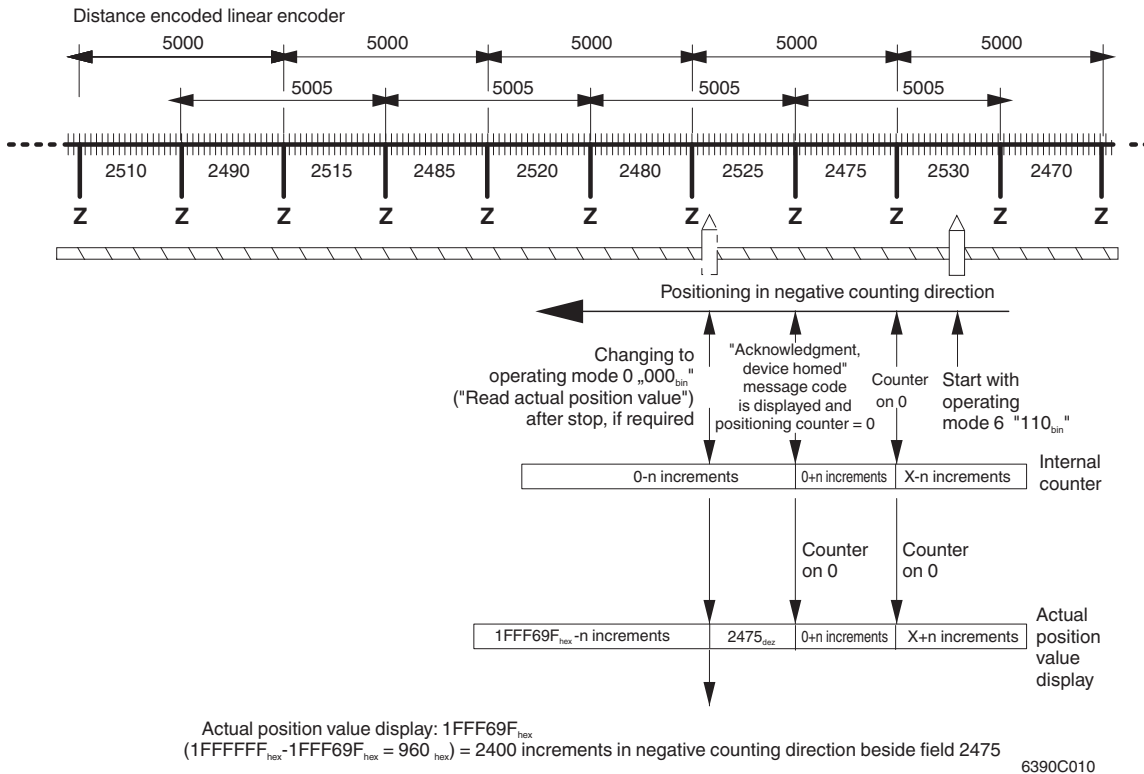

Figure 7 Example 1: Positioning in positive counting direction

6390C009



10 Process data words

10.1 IN process data words

(Word.bit) view	Word	Word 0															
	Bit	15	14	13	12	11	10	9	8	7	6	5	4	3	2	1	0
(Byte.bit) view	Byte	Byte 0								Byte 1							
	Bit	7	6	5	4	3	2	1	0	7	6	5	4	3	2	1	0
IN[0]	Assignment	Error/message code				I3	I2	I1	Actual position value								

(Word.bit) view	Word	Word 1															
	Bit	15	14	13	12	11	10	9	8	7	6	5	4	3	2	1	0
(Byte.bit) view	Byte	Byte 2								Byte 3							
	Bit	7	6	5	4	3	2	1	0	7	6	5	4	3	2	1	0
IN[1]	Assignment	Position actual value															

Error/message code:	See Table "Error/message code" on page 16
Status bit I1:	Status input 1
Status bit I2:	Status input 2
Status bit I3:	Status input 3
Actual position value:	Contents of the positioning counter (25 bits)

10.2 Error/message code

IN[0]				Description
Bit				
15	14	13	12	
0	0	0	1	Acknowledgment, device homed
0	0	0	0	No error, device not (yet) homed
0	0	1	0	Test mode activated
0	1	0	0	Homing initiated several times If the set operating mode 1 to 6 for a homing function is changed before the terminal has output the "Device homed" acknowledgment, the "Homing initiated several times" error code is generated.
1	0	0	0	Actual position value invalid (voltage supply)
1	0	1	0	Actual position value invalid (encoder error)
1	1	0	0	Homing not possible, as evaluation not set
1	1	1	0	Actual position value invalid/evaluation changed during operation



After successful execution of the homing process status bit 12 (IN[0]) "Acknowledgment, device homed" is set. It is present until an error occurs or a new homing process is initialized.

10.3 OUT process data words

The process data output words specify the output values in each cycle.

(Word.bit) view	Word	Word 0																
	Bit	15	14	13	12	11	10	9	8	7	6	5	4	3	2	1	0	
(Byte.bit) view	Byte	Byte 0								Byte 1								
	Bit	7	6	5	4	3	2	1	0	7	6	5	4	3	2	1	0	
OUT[0]	Assignment	Operating mode				Evaluation and encoder type				OB	Reference point value for homing function							

(Word.bit) view	Word	Word 1															
	Bit	15	14	13	12	11	10	9	8	7	6	5	4	3	2	1	0
(Byte.bit) view	Byte	Byte 2								Byte 3							
	Bit	7	6	5	4	3	2	1	0	7	6	5	4	3	2	1	0
OUT[1]	Assignment	Reference point value for homing function															

Operating mode:

See Table "Control codes for selecting the operating mode" on page 18

Evaluation and encoder type:

See Table "Control codes for selecting the evaluation and encoder type"

OB control bit:

Set output bit (activates the "open collector" output of I3). Terminal point I3 can be used as the 24 V input or as the output with negative logic. The output connects terminal point I 3 to GND when the OB control bit is set.

Reference point value for homing function:

During homing, this value is transferred to the positioning counter, i.e., from this point onwards the reference point value forms the output value for position detection (value range 0 to 2^{25} ... 1).



NOTE: Misinterpretation of values when the data consistency is violated

Ensure a data consistency of two words to prevent the possibility of misinterpretation of the values.

10.4 Control codes for selecting the evaluation and encoder type

OUT[0]			Description
Bit			
12	11	10	
0	0	0	No evaluation (no function)
0	0	1	Twofold evaluation, symmetrical encoder signals
0	1	0	Fourfold evaluation, symmetrical encoder signals
0	1	1	Single evaluation, symmetrical encoder signals
1	0	0	No evaluation (no function)
1	0	1	Twofold evaluation, asymmetrical encoder signals
1	1	0	Fourfold evaluation, asymmetrical encoder signals
1	1	1	Single evaluation, asymmetrical encoder signals

10.5 Control codes for selecting the operating mode

Operating mode	OUT[0]			Description
	Bit 15	Bit 14	Bit 13	
0	0	0	0	<p>Read actual position value</p> <p>The positioning counter is continuously displayed in the actual position value (IN process data words 0 and 1).</p>
1	0	0	1	<p>Set counter to reference point value (standstill homing)</p> <p>The reference point value is loaded to the positioning counter and the counter immediately starts to count the incoming pulses. The "Acknowledgment, device homed" message code is displayed.</p> <p>The homing function is exited by changing to operating mode 0 ("Read actual position value"). In this mode, the positioning counter is continuously displayed.</p>
2	0	1	0	<p>Homing on the next positive edge of input I1, I2 or I3* without Z</p> <p>The reference point value is loaded in the counting register with a positive edge from one of the inputs and the "Acknowledgment, device homed" message code is displayed.</p> <p>The homing function is exited by changing to operating mode 0 ("Read actual position value"). In this mode, the positioning counter is continuously displayed.</p>
3	0	1	1	<p>Homing on the next negative edge of input I1, I2 or I3* without Z</p> <p>The reference point value is loaded in the counting register with a negative edge from one of the inputs and the "Acknowledgment, device homed" message code is displayed.</p> <p>The homing function is exited by changing to operating mode 0 ("Read actual position value"). In this mode, the positioning counter is continuously displayed.</p>
4	1	0	0	<p>Homing on Z after positive edge of input I1, I2 or I3*</p> <p>The delta counting register is set to "0" with a positive edge from one of the inputs. The position value gives a positive count value, which indicates the difference between the input edge and the next positive edge of Z (adjustment value). When Z is reached, the "Acknowledgment, device homed" message code is displayed and the reference point value is loaded in the counting register. The delta value is displayed until the operating mode is changed to "Read actual position value".</p> <p>The homing function is exited by changing to operating mode 0 ("Read actual position value"). In this mode, the positioning counter is continuously displayed.</p>

Operating mode	OUT[0]			Description
	Bit 15	Bit 14	Bit 13	
5	1	0	1	<p>Homing on Z after negative edge of input I1, I2 or I3*</p> <p>The delta counting register is set to "0" with a negative edge from one of the inputs. The position value gives a positive count value, which indicates the difference between the input edge and the next positive edge of Z (adjustment value). When Z is reached, the "Acknowledgment, device homed" message code is displayed and the reference point value is loaded in the counting register. The delta value is displayed until the operating mode is changed to "Read actual position value".</p> <p>The homing function is exited by changing to operating mode 0 ("Read actual position value"). In this mode, the positioning counter is continuously displayed.</p>
6	1	1	0	<p>Homing distance encoded incremental encoders</p> <p>The delta counting register is set to zero with the first positive edge of the Z signal. The position value gives a positive count value, which indicates the delta between the two Z signals with the second positive edge of the Z signal. When the second Z signal is reached, the "Acknowledgment, device homed" message code is displayed and the reference point value is loaded in the counting register. The delta value is displayed until the operating mode is changed to "Read actual position value".</p> <p>The positioning counter is continuously displayed when changing to operating mode 0 ("Read actual position value").</p>
7	1	1	1	<p>Test mode</p> <p>The delta counting register is set to "0" with a positive edge from the Z signal. The delta counting register is again set to "0" with a second positive edge of Z and the position value gives a positive count value, which indicates the delta between the last two Z signals.</p>

* Terminal point I3 can be used as the 24 V input or as the output with negative logic.

The output connects terminal point I3 to GND, when output bit OUT[0], bit 9 is set. In order for I3 to be used as an input, output bit OUT[0], bit 9 must be equal to 0.

Application example: A 0 V enable signal is required for the Z index pulse in an incremental length measuring system (ELGO Electric, Rielasingen, Germany).



Ensure that the difference between the limit switch and the first Z edge is always specified as a positive value, even if the direction of rotation or the traversing direction is negative.



NOTE:

Inputs I1 to I3 are active at the same time for the homing function in modes 2 to 5. If I3 is used as an "open collector" output, the following should be observed:

To ensure the input edges of I3 are not misinterpreted during homing, do not change output bit OUT[0], bit 9 after activating homing modes 2 to 5.



SCATTERGOOD & JOHNSON LTD

ELECTRICAL ENGINEERING & FLUID CONTROL DISTRIBUTORS

Est.1899

At Scattergood & Johnson Ltd, we pride ourselves on being a technical distributor to specialist industries.

Working with a range of quality product suppliers across a number of specialist markets, we are not your average 'box shifter' - we are your technical and supply chain partner.

We fully support every product we sell - for free! Our internal team and external sales engineers can answer any product or application question, no matter the complexity.

Backing up this technical ability is a range of 50,000+ products available from stock for nationwide next day delivery (same day if required!), or you can collect what you need from any of our trade counters around the UK.

Select your specialist interest below to learn more about how we can help.



Online, In Branch and On the Road - Scattergood & Johnson Ltd, there when you need us.

www.scatts.co.uk