

# IB IL CNT-PAC

**Inline counter terminal, 1 counter input, 1 control input, 1 output, 24 V DC, 500 mA**

Data sheet  
6987\_en\_05

© PHOENIX CONTACT 2019-06-18

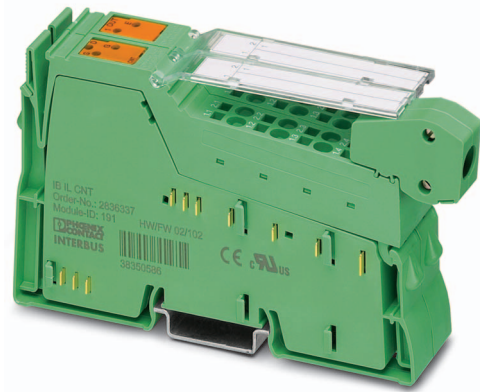

## 1 Description

The terminal is designed for use within an Inline station. The counter terminal acquires and processes fast pulse sequences from sensors. It has a counter input (source), a control input (gate), and a switching output that can be freely parameterized. The switching output is set independently of the terminal. Fast response times can therefore be achieved, which are independent of both the bus and controller.

The terminal can be operated in four different operating modes: frequency measurement, event counting, time measurement, and pulse generation (pulse generator).

### Features

- 1 counter input
- 1 control input
- 1 1 freely parameterizable switching output
- Four operating modes: event counting, time or state-controlled frequency measurement, time measurement (period or pulse length), and pulse generator
- Processing of 5 V or 24 V signals
- Input frequency of up to 100 kHz
- 16-bit counter value for time measurement
- 24-bit counter value for event counting and frequency measurement



This data sheet is only valid in association with the IL SYS INST UM E user manual.



For additional information, please refer to the user manual for the counter terminal.



Make sure you always use the latest documentation.

It can be downloaded at: [phoenixcontact.net/product/2861852](https://phoenixcontact.net/product/2861852)

<b>2</b>	<b>Table of contents</b>	
1	Description .....	1
2	Table of contents .....	2
3	Ordering data .....	3
4	Technical data .....	3
5	Additional tables .....	8
6	Internal circuit diagram .....	9
7	Terminal point assignment.....	10
8	Connection example.....	10
9	Local diagnostic and status indicators .....	11
10	Function description .....	11

### 3 Ordering data

Description	Type	Order No.	Pcs./Pkt.
Inline counter terminal block, complete with accessories (connectors and labeling fields), 1 counter input, 1 control input, 1 output, 24 V DC, 500 mA, 3-wire connection method	IB IL CNT-PAC	2861852	1
Accessories	Type	Order No.	Pcs./Pkt.
Connector set (Connector/Adapter)	IB IL AO/CNT-PLSET	2732664	1
Labeling field, width: 12.2 mm (Marking)	IB IL FIELD 2	2727501	10
Insert strip, Sheet, white, unlabeled, can be labeled with: Office printing systems: Laser printer, mounting type: insert, lettering field size: 62 x 10 mm (Marking)	ESL 62X10	0809492	1
Connector, for digital 1, 2 or 8-channel Inline terminals (Connector/Adapter)	IB IL SCN-8	2726337	10
Inline shield connector (Connector/Adapter)	IB IL SCN-6 SHIELD	2726353	5
Documentation	Type	Order No.	Pcs./Pkt.
User manual, English, Inline Modular counter terminal	IB IL CNT UM E	-	-
User manual, English, Automation terminals of the Inline product range	IL SYS INST UM E	-	-
Data sheet, English, INTERBUS addressing	DB GB IBS SYS ADDRESS	-	-

### 4 Technical data

#### Dimensions (nominal sizes in mm)

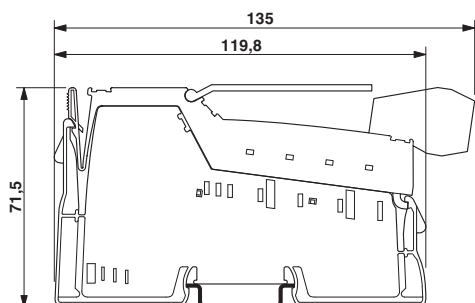

Width	24.4 mm
Height	135 mm
Depth	71.5 mm

<b>General data</b>	
Color	green
Weight	130 g (with connectors)
Operating mode	Process data operation with 2 words
Ambient temperature (operation)	-25 °C ... 55 °C
Ambient temperature (storage/transport)	-25 °C ... 85 °C
Permissible humidity (operation)	10 % ... 95 % (non-condensing)
Permissible humidity (storage/transport)	10 % ... 95 % (non-condensing)
Air pressure (operation)	70 kPa ... 106 kPa (up to 3000 m above sea level)
Air pressure (storage/transport)	70 kPa ... 106 kPa (up to 3000 m above sea level)
Degree of protection	IP20
Protection class	III, IEC 61140, EN 61140, VDE 0140-1
<b>Connection data: Inline connector</b>	
Connection method	Spring-cage connection
Conductor cross section solid / stranded	0.08 mm <sup>2</sup> ... 1.5 mm <sup>2</sup> / 0.08 mm <sup>2</sup> ... 1.5 mm <sup>2</sup>
Conductor cross section [AWG]	28 ... 16
Stripping length	8 mm
<b>Connection data for UL approvals: Inline connector</b>	
Connection method	Spring-cage connection
Conductor cross section solid / stranded	0.2 mm <sup>2</sup> ... 1.5 mm <sup>2</sup> / 0.2 mm <sup>2</sup> ... 1.5 mm <sup>2</sup>
Conductor cross section [AWG]	24 ... 16
Stripping length	8 mm
<b>Interface: Inline local bus</b>	
Number	2
Connection method	Inline data jumper
Transmission speed	500 kbps
Transmission physics	Copper
<b>Communications power (U<sub>L</sub>)</b>	
Supply voltage	7.5 V DC (via voltage jumper)
Current consumption	typ. 40 mA max. 50 mA
Power consumption	max. 0.375 W (at U <sub>L</sub> )
<b>Segment circuit supply (U<sub>S</sub>)</b>	
Supply voltage	24 V DC (via voltage jumper)
Current consumption	min. 0 A (without connected peripherals) max. 1 A
<b>Supply: Power supply for sensors</b>	
Supply voltage	24 V DC (generated from segment supply U <sub>S</sub> )
Current carrying capacity	max. 500 mA
Behavior in case of short-circuit	Auto restart after eliminating the short-circuit

**Power dissipation**

Maximum power dissipation for nominal condition	1.2 W
---	-------

**Counter input for 24 V signals**

Number of inputs	1 (only one counter input can be used, either for 24 V or for 5 V signals)
Operating mode	Event counting, frequency/time measurement
Connection method	Spring-cage connection
Connection technology	2, 3-wire
Input frequency	max. 100 kHz
Input voltage	24 V DC (Nominal voltage)
Nominal input current	typ. 5 mA
Input voltage range "0" signal	0 V DC ... 5 V DC
Input voltage range "1" signal	15 V DC ... 30 V DC
Input resistance	approx. 5.7 k $\Omega$

**Counter input for 5 V signals**

Number of inputs	1 (only one counter input can be used, either for 24 V or for 5 V signals)
Operating mode	Event counting, frequency/time measurement
Connection method	Spring-cage connection
Connection technology	2-wire (shielded), external 5 V supply
Input frequency	max. 100 kHz
Input voltage	5 V DC (Nominal voltage)
Nominal input current	typ. 5 mA
Input voltage range "0" signal	0 V ... 1.5 V
Input voltage range "1" signal	3.5 V ... 8 V
Input resistance	approx. 1.7 k $\Omega$

**Control input for 24 V signals**

Number of inputs	1 (only one control input can be used, either for 24 V or for 5 V signals)
Operating mode	Event counting, frequency/time measurement
Connection method	Spring-cage connection
Connection technology	2, 3-wire
Input voltage	24 V DC (Nominal voltage)
Nominal input current	typ. 5 mA
Input voltage range "0" signal	0 V ... 5 V
Input voltage range "1" signal	15 V ... 30 V
Input resistance	approx. 5.7 k $\Omega$

**Control input for 5 V signals**

Number of inputs	1 (only one control input can be used, either for 24 V or for 5 V signals)
Operating mode	Event counting, frequency/time measurement
Connection method	Spring-cage connection
Connection technology	2-wire (shielded), external 5 V supply
Input voltage	5 V DC (Nominal voltage)
Nominal input current	typ. 5 mA
Input voltage range "0" signal	0 V ... 1.5 V
Input voltage range "1" signal	3.5 V ... 8 V
Input resistance	approx. 1.7 k $\Omega$

**Switching output**

Number of outputs	1
Connection method	Spring-cage connection
Connection technology	2-wire
Output voltage	24 V DC (Nominal voltage)
Output current	max. 0.5 A (Nominal current)
Voltage difference with nominal current	< 1 V
Nominal load, ohmic	max. 12 W (48 $\Omega$ )
Nominal load, inductive	max. 12 VA (1.2 H, 48 $\Omega$ )
Nominal load, lamp	max. 12 W
Signal delay when switching on an ohmic nominal load	< 50 $\mu$ s
Signal delay when switching on an inductive nominal load	< 1 ms
Signal delay when switching on a lamp nominal load	< 25 $\mu$ s
Signal delay when switching off an ohmic nominal load	< 1 ms
Signal delay when switching off an inductive nominal load	< 30 ms
Signal delay when switching off a lamp nominal load	< 1 ms
Limitation of the voltage induced on circuit interruption	approx. -18 V
Behavior in the event of ohmic overload	Auto restart after eliminating the overload
Behavior with inductive overload	Output can be destroyed
Behavior in the event of lamp overload	Auto restart after eliminating the overload



The characteristics of a bulb can delay the auto restart significantly after eliminating the overload. The delay time can be reduced by briefly setting the output.

Reverse voltage resistance to short pulses	Reverse voltage proof
Resistance to permanently applied surge voltage	no
Overcurrent shut-down	min. 0.7 A
Short-circuit protection	Yes, short-circuit-proof (automatically switched on again)
Overload protection	yes

**Programming data (INTERBUS, local bus)**

ID code (hex)	BF
ID code (dec.)	191
Length code (hex)	02
Length code (dec.)	02
Process data channel	32 Bit
Input address area	4 Byte
Output address area	4 Byte
Parameter channel (PCP)	0 Byte
Register length (bus)	4 Byte



For the programming data/configuration data of other bus systems, please refer to the corresponding electronic device data sheet (e.g., GSD, EDS).

**NOTE: Misinterpretation of values when the data consistency is violated**

Ensure data consistency of two words to prevent the possibility of the values being misinterpreted.

**Configuration and parameter data in a PROFIBUS system**

Required parameter data	1 Byte
Required configuration data	5 Byte

**Error messages to the higher level control or computer system**

Sensor supply short-circuit

Sensor supply overload



If the sensor supply is short-circuited, the red E LED (Error) lights up and an I/O error message is generated after a delay of typically 1.4 s.  
In addition, the D LED (Diagnostics) flashes on the terminal at 2 Hz (medium).

**Electrical isolation/isolation of the voltage areas**

Test section	Test voltage
7.5 V supply (bus logics)/24 V supply (I/O)	500 V AC, 50 Hz, 1 min.
7.5 V supply (bus logics) / functional earth ground	500 V AC, 50 Hz, 1 min.
24 V supply (I/O) / functional earth ground	500 V AC, 50 Hz, 1 min.



To achieve electrical isolation between the logic level and the I/O area, supply these areas from separate power supply units. Interconnection of the power supply units in the 24 V area is not permitted (see IL SYS INST UM E user manual).

**Approvals**

For the latest approvals, please visit [phoenixcontact.net/products](http://phoenixcontact.net/products).

## 5 Additional tables

Control and counter input	
Input characteristic curve	
Input voltage (V)	Typical input current (mA)
$-0.5 < U_{IN} < 0$	0
3	0.6
6	1.1
9	1.7
12	2.3
15	2.4
18	3.6
21	4.3
24	5.0
27	5.5
30	6.1

Switching output	
Output characteristic curve when switched on (typical)	
Output current (A)	Differential output voltage (V)
0	0
0.1	0.25
0.2	0.35
0.3	0.45
0.4	0.55
0.5	0.65

Sensor supply	
Output characteristic curve when switched on (typical)	
Output current (A)	Differential output voltage (V)
0	0
0.1	0.18
0.2	0.22
0.3	0.27
0.4	0.31
0.5	0.36

Limit values and limitations in the operating modes			
Operating mode	Affected option		Operating range
Frequency measurement	All		$f \leq 100 \text{ kHz}$
Event counting	All		$f \leq 100 \text{ kHz}$
Time measurement	Resolution $2 \mu\text{s}$	Without relation condition	$250 \mu\text{s} \leq t \leq 126 \text{ ms}$
		With relation condition	$1 \text{ ms} \leq t \leq 126 \text{ ms}$
	Resolution $2 \text{ ms}$		$2 \text{ ms} \leq t \leq 131 \text{ s}$
	Resolution $10 \text{ ms}$		$10 \text{ ms} \leq t \leq 655 \text{ s}$
Pulse generator			$1 \text{ kHz} \leq f \leq 10 \text{ kHz}$

Notes on using the counter terminal	
Minimum time measurement period	The minimum time measurement periods with a resolution of $2 \mu\text{s}$ , with and without relation condition, are defined by the firmware by means of the processing time.
Input signals at source and gate	The input signals at source and gate must be digital.
Switch	The counter terminal is primarily designed for the use of electronic switching elements, i.e., semiconductor switches.  Mechanical contacts can only be used to a limited extent. A filter is provided in the input circuit for this purpose. However, practical tests have shown that the bouncing of mechanical contacts can present problems even with this filter.



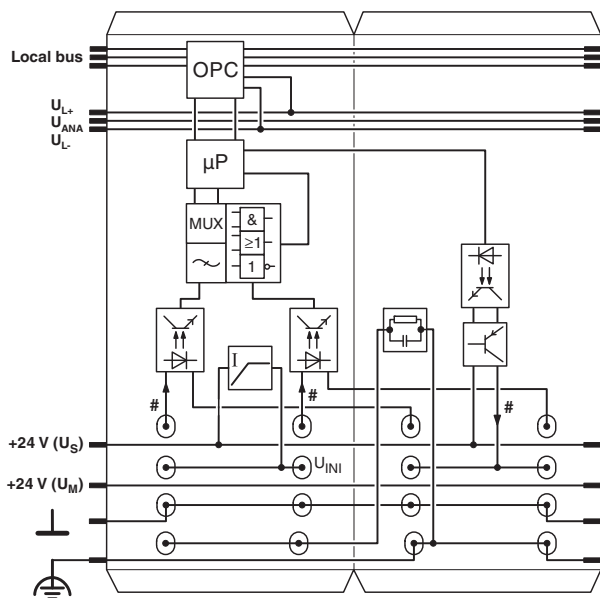





## 6 Internal circuit diagram



Please refer to the IL SYS INST UM E user manual for an explanation of other symbols used.

Figure 1 Internal wiring of the terminal points

Key:

- Local bus Local bus
-  Protocol chip  
(Bus logic including voltage conditioning)
-  Microprocessor
-  Optocoupler
-  Digital input
-  Digital output
-  Transistor
-  Coupling network
-  Module with multiplexer, filter, and logic
-  Sensor supply with short-circuit protection

## 7 Terminal point assignment

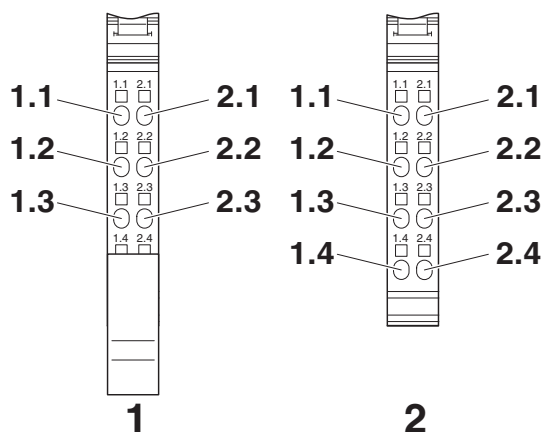

Figure 2 Terminal point assignment

Terminal point	Signal	Assignment
<b>Connector 1</b>		
1.1	S+	24 V counter input (source)
2.1	G+	24 V control input (gate)
1.2, 2.2	$U_{INI}$	24 V DC sensor voltage
1.3	S-	Reference ground for the counter input (source) and the sensor voltage
2.3	G-	Reference ground for the control input (gate) and the sensor voltage
1.4, 2.4	Shield	Shield (capacitively coupled to FE)
<b>Connector 2</b>		
1.1	S+*	5 V counter input (source)
2.1	G+*	Control input 5 V (gate)
1.2, 2.2	OUT	Output; the terminal points are jumpered internally.
1.3, 2.3	GND	Reference ground for the output; the terminal points are jumpered internally.
1.4, 2.4	FE	Functional earth ground (connected directly to FE)



The short-circuit-protected sensor voltage  $U_{INI}$  is generated from the segment voltage  $U_S$ . The main voltage  $U_M$  is not used at the counter terminal points.

## 8 Connection example

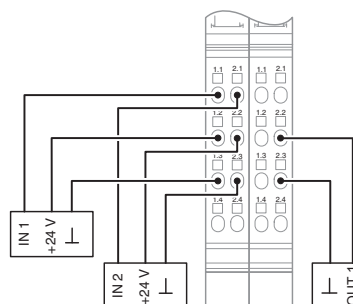

Figure 3 Connection example



When connecting the sensors observe the assignment of the terminal points to the process data. This can be found in the user manual for the counter terminal.

## 9 Local diagnostic and status indicators

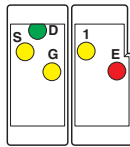

Figure 4 Local diagnostic and status indicators

Designation	Color	Meaning
D	Green	Diagnostics (bus and logic voltage)
	On	Local bus active.
	Flashing	
	0.5 Hz: (slow)	Communications power not present, bus system is not active
	2 Hz: (medium)	Communications power present, bus active, I/O error.
	4 Hz: (fast)	Communications power present, bus connection to the flashing terminal has failed; terminals behind the flashing terminal are not part of the configuration frame
	Off	Communications power not present, bus system is not active
E	Red	Sensor supply short-circuit
	On	Connector 1 short-circuited between terminals 1.2 and 1.3 or between terminals 2.2 and 2.3
	Off	No error
S	Yellow	Status of the counter input (source)
	On	Input is active.
	Off	Input is inactive.
G	Yellow	Status of the control input (gate)
	On	Input is active.
	Off	Input is inactive.
1	Yellow	Output status
	On	Output is set.
	Off	Output is not set.

### Function identification

Orange

## 10 Function description



An overview of the function of the terminal is provided here. For a more detailed description, please refer to the user manual for the counter terminal.

- Event counting:  
The counting conditions and the output switching behavior can be selected.
- Frequency measurement:  
Time-driven or state-driven frequency measurements with gate times (time in which measurement is performed) from 10 ms to 10 s are possible.
- Time measurement:  
Relation conditions can be evaluated during time measurement. The result of the evaluation can be output via the process data or the digital output. This allows a controlled response when values exceed or fall below the limit values.
- Pulse generator:  
The pulse generator generates square-wave signals with frequencies of 1 kHz to 10 kHz in 500 Hz increments.
- The event counting and frequency measurement modes yield a 24-bit measured value.
- The time measurement mode yields a 16-bit measured value.
- A combination of source and gate signal can be selected as a counter signal.
- During operation, a start value or final value can be changed without the counter having to be stopped.
- An RC filter can be connected to source and gate. This allows the use of mechanical switches.
- It is not necessary to send a counter start command to start the counting process. Counting starts immediately after the command for selecting the operating mode is transmitted.



For additional information on the terminal, such as a description of the process data and commands, as well as examples, please refer to the UM EN IB IL CNT-PAC user manual.



# SCATTERGOOD & JOHNSON LTD

ELECTRICAL ENGINEERING & FLUID CONTROL DISTRIBUTORS

Est.1899

At Scattergood & Johnson Ltd, we pride ourselves on being a technical distributor to specialist industries.

Working with a range of quality product suppliers across a number of specialist markets, we are not your average 'box shifter' - we are your technical and supply chain partner.

We fully support every product we sell - for free! Our internal team and external sales engineers can answer any product or application question, no matter the complexity.

Backing up this technical ability is a range of 50,000+ products available from stock for nationwide next day delivery (same day if required!), or you can collect what you need from any of our trade counters around the UK.

Select your specialist interest below to learn more about how we can help.



Online, In Branch and On the Road - Scattergood & Johnson Ltd, there when you need us.

# [www.scatts.co.uk](http://www.scatts.co.uk)