

AUTOMATION



User manual

UM EN IL PB BK DP/V1

Order No.: -

Configuring and installing the
PROFIBUS DP/V1 bus coupler
for the Inline product range

AUTOMATION

User Manual

Configuring and installing the PROFIBUS DP/V1 bus coupler for the Inline product range

11/2008

Designation: UM EN IL PB BK DP/V1

Revision: 05

Order No.: –

This user manual is valid for:

Designation	Order No.
IL PB BK DP/V1	2718688
IL PB BK DP/V1-PAC	2862246

Please observe the following notes

In order to ensure the safe use of the product described, you have to read and understand this manual. The following notes provide information on how to use this manual.

User group of this manual

The use of products described in this manual is oriented exclusively to qualified electricians or persons instructed by them, who are familiar with applicable standards and other regulations regarding electrical engineering and, in particular, the relevant safety concepts.

Phoenix Contact accepts no liability for erroneous handling or damage to products from Phoenix Contact or third-party products resulting from disregard of information contained in this manual.

Explanation of symbols used and signal words



This is the safety alert symbol. It is used to alert you to potential personal injury hazards. Obey all safety messages that follow this symbol to avoid possible injury or death.



DANGER

This indicates a hazardous situation which, if not avoided, will result in death or serious injury.



WARNING

This indicates a hazardous situation which, if not avoided, could result in death or serious injury.



CAUTION

This indicates a hazardous situation which, if not avoided, could result in minor or moderate injury.

The following types of messages provide information about possible property damage and general information concerning proper operation and ease-of-use.



NOTE

This symbol and the accompanying text alerts the reader to a situation which may cause damage or malfunction to the device, either hardware or software, or surrounding property.



This symbol and the accompanying text provides additional information to the reader. It is also used as a reference to other sources of information (manuals, data sheets, literature) on the subject matter, product, etc.

General terms and conditions of use for technical documentation

Phoenix Contact reserves the right to alter, correct, and/or improve the technical documentation and the products described in the technical documentation at its own discretion and without giving prior notice, insofar as this is reasonable for the user. The same applies to any technical changes that serve the purpose of technical progress.

The receipt of technical documentation (in particular data sheets, installation instructions, manuals, etc.) does not constitute any further duty on the part of Phoenix Contact to furnish information on alterations to products and/or technical documentation. Any other agreement shall only apply if expressly confirmed in writing by Phoenix Contact. Please note that the supplied documentation is product-specific documentation only and that you are responsible for checking the suitability and intended use of the products in your specific application, in particular with regard to observing the applicable standards and regulations. Although Phoenix Contact makes every effort to ensure that the information content is accurate, up-to-date, and state-of-the-art, technical inaccuracies and/or printing errors in the information cannot be ruled out. Phoenix Contact does not offer any guarantees as to the reliability, accuracy or completeness of the information. All information made available in the technical data is supplied without any accompanying guarantee, whether expressly mentioned, implied or tacitly assumed. This information does not include any guarantees regarding quality, does not describe any fair marketable quality, and does not make any claims as to quality guarantees or guarantees regarding the suitability for a special purpose.

Phoenix Contact accepts no liability or responsibility for errors or omissions in the content of the technical documentation (in particular data sheets, installation instructions, manuals, etc.).

The aforementioned limitations of liability and exemptions from liability do not apply, in so far as liability must be assumed, e.g., according to product liability law, in cases of premeditation, gross negligence, on account of loss of life, physical injury or damage to health or on account of the violation of important contractual obligations. Claims for damages for the violation of important contractual obligations are, however, limited to contract-typical, predictable damages, provided there is no premeditation or gross negligence, or that liability is assumed on account of loss of life, physical injury or damage to health. This ruling does not imply a change in the burden of proof to the detriment of the user.

IL PB BK DP/V1

Statement of legal authority

This manual, including all illustrations contained herein, is copyright protected. Use of this manual by any third party is forbidden. Reproduction, translation, and public disclosure, as well as electronic and photographic archiving or alteration requires the express written consent of Phoenix Contact. Violators are liable for damages.

Phoenix Contact reserves all rights in the case of patent award or listing of a registered design. Third-party products are always named without reference to patent rights. The existence of such rights shall not be excluded.

How to contact us**Internet**

Up-to-date information on Phoenix Contact products and our Terms and Conditions can be found on the Internet at:

www.phoenixcontact.com.

Make sure you always use the latest documentation.

It can be downloaded at:

www.download.phoenixcontact.com.

A conversion table is available on the Internet at:

www.download.phoenixcontact.com/general/7000_en_00.pdf.

Subsidiaries

If there are any problems that cannot be solved using the documentation, please contact your Phoenix Contact subsidiary.

Subsidiary contact information is available at www.phoenixcontact.com.

Published by

PHOENIX CONTACT GmbH & Co. KG
Flachsmarktstraße 8
32825 Blomberg
Germany
Phone +49 - (0) 52 35 - 3-00
Fax +49 - (0) 52 35 - 3-4 12 00

PHOENIX CONTACT
P.O. Box 4100
Harrisburg, PA 17111-0100
USA
Phone +1-717-944-1300

Should you have any suggestions or recommendations for improvement of the contents and layout of our manuals, please send your comments to

tecdoc@phoenixcontact.com.

Table of contents

1	The PROFIBUS DP/V1 bus coupler	1-1
1.1	The PROFIBUS system	1-1
1.2	Properties of the PROFIBUS DP/V1 bus coupler	1-1
2	From configuration through to startup	2-1
2.1	Configuring an Inline station	2-1
2.1.1	Describing and defining the task	2-1
2.1.2	Selecting the required Inline terminals	2-1
2.1.3	Considering the system limits	2-2
2.1.4	Selecting power supplies	2-2
2.1.5	Selecting the PROFIBUS cable	2-3
2.2	Installing and connecting a PROFIBUS DP/V1 bus coupler station	2-4
2.2.1	Safety notes	2-4
2.2.2	Installation notes	2-4
2.2.3	Structure of an Inline station with a PROFIBUS DP/V1 bus coupler	2-5
2.2.4	General tips and notes on setting up the PROFIBUS DP/V1 bus coupler station	2-6
2.2.5	Connecting the PROFIBUS DP/V1 bus coupler	2-7
2.2.6	Securing cables	2-8
2.2.7	Connecting PROFIBUS	2-8
2.2.8	Connecting grounding	2-10
2.3	Supply at the PROFIBUS DP/V1 bus coupler	2-11
2.4	Electrical potential and data routing	2-12
2.4.1	Circuits and provision of supply voltages	2-12
2.4.2	Example of a circuit diagram	2-13
2.5	Connecting Inline terminals	2-14
2.6	Diagnostics on the PROFIBUS DP/V1 bus coupler	2-15
2.7	Configuration and startup of the Inline station on PROFIBUS	2-16
2.7.1	Hardware configuration	2-16
2.7.2	Mains termination resistors	2-16
2.7.3	Configuration and startup using the STEP 7® SIMATIC® Manager	2-17
2.7.4	Selecting parameters	2-30
2.7.5	Failsafe values	2-34
2.7.6	Diagnostics	2-37
2.7.7	Acknowledging peripheral faults	2-44
2.7.8	Byte rotation for IB IL 24 DI 16/IB IL 24 DO 1 terminals	2-46
2.7.9	Byte rotation for IB IL 24 DI 32/IB IL 24 DO 32 terminals	2-47
2.7.10	Data exchange and global command "Operate"	2-48
2.8	Response monitoring	2-49

IL PB BK DP/V1

3	Acyclic communication (DP/V1 and PCP).....	3-1
3.1	Acyclic communication via the Class 1 master (C1 master)	3-1
3.2	Acyclic communication via the Class 2 master (C2 master)	3-2
3.3	PCP communication basics	3-3
3.4	Acyclic communication in DP/V1 mode	3-5
3.4.1	The communication mechanism	3-5
3.4.2	Examples	3-9
3.5	PCP communication via process data (C1 master in DP/V0 mode).....	3-20
3.5.1	Mechanism for transmission in the process data	3-20
3.5.2	Examples for VC1 services	3-26
4	Dynamic configuration	4-1
4.1	Empty spaces.....	4-1
4.2	Dynamic configuration	4-4
4.3	Startup.....	4-6
4.3.1	Planning configuration	4-6
4.3.2	Options for specifying the active configuration	4-7
4.3.3	Specifying the active configuration	4-8
4.4	Modifying the station structure.....	4-11
5	What to do in the event of an error	5-1
5.1	Local diagnostics.....	5-1
5.1.1	Diagnostic and status indicators on the PROFIBUS DP/V1 bus coupler	5-2
5.1.2	Error causes and remedies on the PROFIBUS DP/V1 bus coupler	5-2
5.1.3	Determining the error cause and remedy	5-3
5.2	Diagnostics on the PROFIBUS master	5-6
5.2.1	PROFIBUS standard diagnostics	5-6
5.2.2	PROFIBUS device-specific diagnostics	5-7
6	Technical data and ordering data	6-1
6.1	Technical data.....	6-1
6.2	Ordering data	6-5
6.2.1	Ordering data for the bus coupler	6-5
6.2.2	Ordering data for accessories	6-5
6.2.3	Ordering data for documentation	6-6

Table of contents

A	Technical appendix.....	A-1
	A 1 Error description	A-1
	A 2 Format of the parameter telegram	A-6
	A 3 Object dictionary for the PROFIBUS DP/V1 bus coupler	A-8
	A 4 Error codes for DP/V1 and VC1 communication	A-12
	A 5 Error codes for PCP communication.....	A-13
B	Index.....	B-1

IL PB BK DP/V1

1 The PROFIBUS DP/V1 bus coupler

1.1 The PROFIBUS system

PROFIBUS is a serial bus system that transmits data between control systems and spatially distributed I/O terminals, to which sensors and actuators are connected.

PROFIBUS has a star/tree structure. In the PROFIBUS topology the individual bus devices can be differentiated by means of their addressing. The communication profiles determine how the devices transmit their data serially via the bus.

In addition to PROFIBUS **FMS** (**F**ieldbus **M**essage **S**pecification) and PROFIBUS **PA** (**P**rocess **A**utomation), PROFIBUS **DP** (**D**istributed **P**eriphery) is the most frequently used communication profile. PROFIBUS DP is normally a single master system, i.e., a master controls all devices of a PROFIBUS DP system. PROFIBUS DP is designed for the easy transmission of input and output data and specifically tailored to communication between automation systems and distributed I/O devices.

1.2 Properties of the PROFIBUS DP/V1 bus coupler

Different versions

This section describes the PROFIBUS DP/V1 bus coupler, which is a further development of the PROFIBUS DP bus coupler.



The PROFIBUS DP/V1 bus coupler has been extended to include dynamic configuration in firmware B or later.

The IL PB BK DP/V1 and IL PB BK DP/V1-PAC only differ in the scope of supply. Their function and technical data are identical. The product designation IL PB BK DP/V1-PAC is used throughout this document.

Features

The key features of the PROFIBUS DP/V1 bus coupler are listed below:

- DP/V1 for Class 1 and Class 2 masters
- Acyclic communication with, e.g., V.24 (RS-232) modules even in the process data channel (*)
- I/O terminal parameterization
- Failsafe values
- Various diagnostic formats
- Acknowledgment of peripheral faults from the user program (*)
- Adaptation of the high byte/low byte format in 16 and 32-channel input and output terminals to the control system format (*)
- Dynamic configuration

IL PB BK DP/V1**DIP switch 8**

DIP switch 8 is particularly important. By default upon delivery, it is in the "OFF" position. This means that the device can directly replace the previous version although it also offers a few new functions, see above (*). However, these functions can only be used on the new devices. When configuring the device, use GSD file "PXC_00F0.GSD" and device entry "IL PB BK DP/V1 (DIP8 = OFF)" in the hardware list.



The required bus coupler GSD file is available at www.download.phoenixcontact.com.

In the "ON" position, the device offers all of the above functions and has a new PROFIBUS ID number.

It should therefore be configured and parameterized using GSD file "PXC_06CC.GSD" and device entry "IL PB BK DP/V1 (DIP8 = ON)" in the hardware list. The stop behavior, which was specified by this switch on the old device, is set in the parameterization.

Table 1-1 Overview of firmware functions

PROFIBUS	IL PB BK DI8 DO4/EF-PA C	IL PB BK DI8 DO4-PAC	IL PB BK DP/V1-PAC	
			DP/V0 mode	DP/V1 mode
Can be replaced with IL PB BK	No	No	Yes	No
DP/V0 supported (cyclic communication)	Maximum of 488 bytes of process data	Maximum of 488 bytes of process data	Maximum of 184 bytes of process data	Maximum of 176 bytes of process data
Number of PCP devices	16, maximum	16, maximum	8, maximum	8, maximum
Size of the protocol data unit (PDU size)	64 bytes	64 bytes	64 bytes	64 bytes
Amount of parameter data	237 bytes	237 bytes	168 bytes	168 bytes
Amount of process data				
IN and OUT	488 bytes, maximum	488 bytes, maximum	184 bytes, maximum	176 bytes, maximum
IN	244 bytes, maximum	244 bytes, maximum	184 bytes, maximum	176 bytes, maximum
OUT	244 bytes, maximum	244 bytes, maximum	184 bytes, maximum	176 bytes, maximum
PCP module operation	Yes	Yes	Yes	Yes
Supports DP/V1 read and DP/V1 write (acyclic communication), Class 1 and Class 2 master	Yes	Yes	No	Yes
Communication with PCP modules via "normal" process data (DP/V0)	Yes	Yes	Yes	Yes

The PROFIBUS DP/V1 bus coupler

PROFIBUS	IL PB BK DI8 DO4/EF-PA C	IL PB BK DI8 DO4-PAC	IL PB BK DP/V1-PAC	
			DP/V0 mode	DP/V1 mode
Parameterization of several I/Os via dialog boxes in the configuration tool	Yes	Yes	No	Yes
Specification of safety values via the configuration tool	Yes	Yes	No	Yes
Byte rotation for IB IL 24 DI 16 and IB IL 24 DO 16 for adaptation to the control system format	Yes	Yes	Yes	Yes
Byte rotation for IB IL 24 DI 32 and IB IL 24 DO 32	Yes	Yes	Yes	Yes *
Operation in the event of terminal failure in the local bus	Yes	Yes	No	No
Acknowledgment of bus stop, either automatically or via the application program	Yes	Yes	Yes	Yes
Acknowledgment of peripheral faults, either automatically or via the application program	Yes	Yes	Yes	Yes
Channel-specific diagnostics	Yes	Yes	Yes	Yes
Diagnostics in identification format	Yes	Yes	No	Yes
Diagnostics as status PDU	Yes	Yes	No	Yes
Stop behavior can be set via DIP switch	No	No	No	No
Stop behavior can be set via parameter telegram	Yes	Yes	Yes	Yes
Transmission invoke ID (e.g., for IB IL POS 200)	Yes	Yes	Yes	Yes *
Dynamic configuration (I/Os reserved in the PLC, e.g., for easy expansion)	Yes	Yes	No	Yes *
Freely selectable station ID (2 bytes) for improved identification in the network	No	No	No	Yes *
Specification of failsafe values via the configuration tool	Yes	Yes	No	Yes

IL PB BK DP/V1

PROFIBUS	IL PB BK DI8 DO4/EF-PA C	IL PB BK DI8 DO4-PAC	IL PB BK DP/V1-PAC	
			DP/V0 mode	DP/V1 mode
Failsafe values even without connection to the PLC	No	No	No	Yes *
Configuration can be stored (additional verification using the last valid configuration)	No	No	No	Yes *
I & M function	Yes	Yes	No	No
Supports PROFIsafe	Yes	No	No	No

The PROFIBUS DP/V1 bus coupler

The PROFIBUS DP/V1 bus coupler is the link between PROFIBUS DP and the Inline installation system. In an existing PROFIBUS DP system, additional machine-mounted I/O modules, such as Fieldline Modular or AS-i devices, can be used with the aid of the PROFIBUS DP/V1 bus coupler.

The intelligent wiring method used by Inline terminals enables the station to be created quickly and easily, since time-consuming wiring of the power supply is not required. It is only necessary for the power supply units integrated in the PROFIBUS DP/V1 bus coupler to be supplied with 24 V DC on the input side. They then generate the required operating voltages for the PROFIBUS DP/V1 bus coupler and the connected I/O terminals.

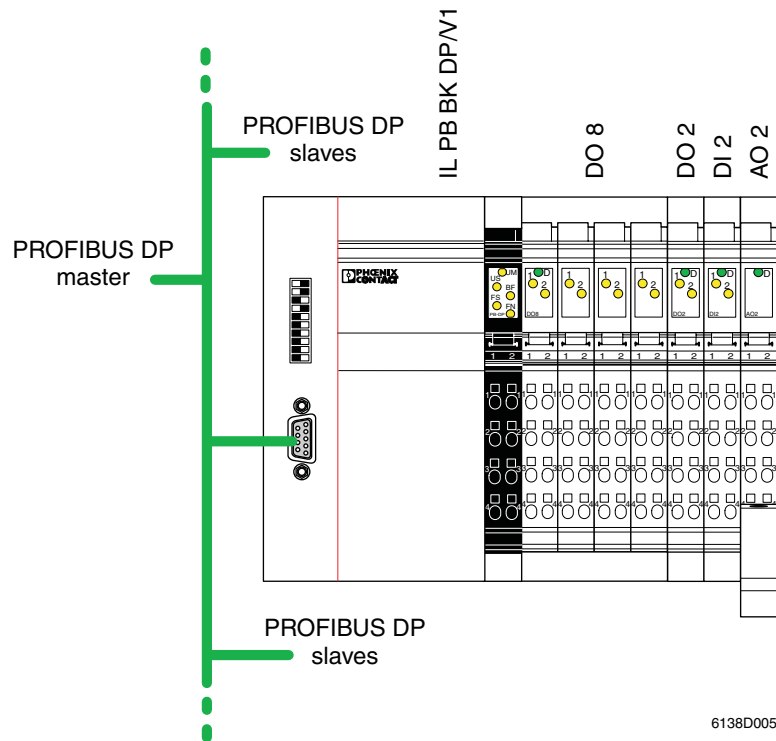

6138D005

Figure 1-1 Typical station with a PROFIBUS DP/V1 bus coupler

IL PB BK DP/V1

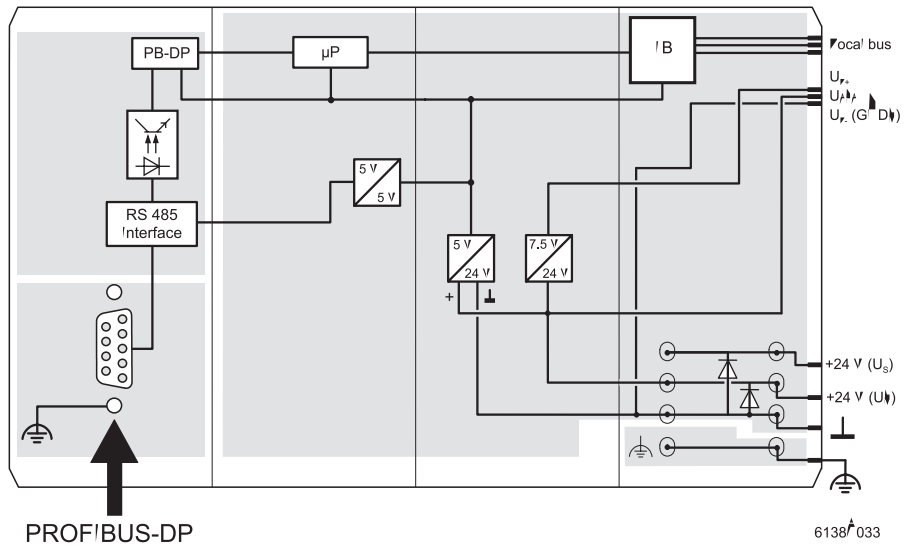



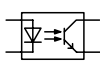



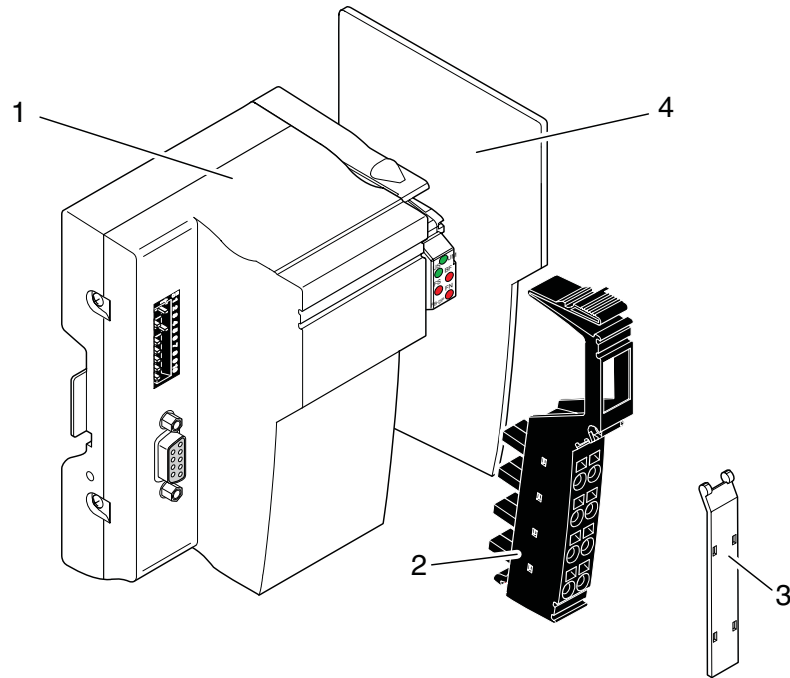

Figure 1-2 Basic circuit diagram of the PROFIBUS DP/V1 bus coupler

Key:

-  Protocol chip
-  Microprocessor
-  Protocol chip
-  Optocoupler
-  Power supply unit with electrical isolation
-  RS-485 interface
-  Electrically isolated area

The PROFIBUS DP/V1 bus coupler



6138C001

Figure 1-3 The PROFIBUS DP/V1 bus coupler

Scope of supply

- PROFIBUS DP/V1 bus coupler (1)
- Power connector (2), only for IL PB BK DP/V1-PAC
- Labeling field (3), only for IL PB BK DP/V1-PAC
- End plate (4)



For the IL PB BK DP/V1, the power connector and labeling field must be ordered separately.

PROFIBUS DP/V1 bus coupler

The bus coupler configures the station and manages data exchange with a PROFIBUS master. It also provides the power supply for the connected Inline terminals.

End plate

The end plate is supplied as standard with the bus coupler and protects the Inline station against ESD pulses. The end plate must always be placed at the end of the station after the last terminal.

**ACHTUNG: Dangerous contact voltage**

For protection against dangerous contact voltage (with 120 V AC/230 V supply), always place the end plate after the last terminal.

GSD file

The characteristic communication features of a PROFIBUS DP device are defined in the form of an electronic device data sheet (GSD, device master data file).

The required bus coupler GSD file is available at www.download.phoenixcontact.com.

IL PB BK DP/V1

Data transmission

The bus coupler is available for connecting copper cables. To transmit data via fiber optics, additional interface converters from Phoenix Contact must be used, e.g., PSM-EG-PROFIB/FO-E/G for glass fibers or PSM-EG-RS485W2/FO-E/K for HCS/polymer fibers.

Potential and data routing

The various potentials and the data signals are distributed within an Inline station using a connection that is created automatically when the terminals are snapped on.

Number of devices

The maximum number of devices that can be connected to a PROFIBUS DP/V1 bus coupler is determined by the following basic system specifications:

- Up to 63 devices can be connected to the bus coupler.



DIP switch 8 can be used to change the operating mode.
 "DIP switch 8 = ON" corresponds to IL PB BK-DP/V1 mode
 "DIP switch 8 = OFF" corresponds to IL PB BK mode

- In "DIP switch 8 = ON" mode, the sum of all input and output data is 176 bytes per station, plus 168 bytes of parameter data. In "DIP switch 8 = OFF" mode, the sum of the process data is 184 bytes.
- The maximum current that can be supplied by the bus coupler in the logic area is 2 A at 7.5 V DC (U_L).
- The maximum current that can be supplied by the bus coupler to analog modules is 0.5 A at 24 V DC (U_{ANA}).
- The maximum current carrying capacity of the potential jumpers is 8 A (total current $U_S + U_M, GND$).



Operation in "DIP switch 8 = ON" mode (IL PB BK-DP/V1 mode) is supported even if the master does not support DP/V1.



For additional information about the address area of I/O terminals on the bus coupler, please refer to the AH IL PB BK DP/V1 (PAC) address area application note.

The PROFIBUS DP/V1 bus coupler

Diagnostics

Diagnostics are provided locally by LEDs on the bus coupler and on the Inline terminals. Diagnostic information is also forwarded to the PROFIBUS master via PROFIBUS DP.



For additional information about the individual circuits within an Inline station, please refer to the IL SYS INST UM E user manual (see Section 6.2.3, "Ordering data for documentation").



Observe the current consumption of each device at the individual potential jumpers when configuring a station. This data can be found in the relevant terminal-specific data sheet.



The permissible number of devices that can be connected depends on the specific station structure. Always observe the basic system specifications given above.

Functions

The PROFIBUS DP/V1 bus coupler forms the head of an Inline station. It connects Inline terminals, Fieldline Modular or AS-i devices to PROFIBUS DP.

The bus coupler generates the communications power U_L for the connected devices from the supplied main voltage U_M . It also provides the supply for the connected analog terminals U_{ANA} .



The potential and data routing of the Inline station begins at the bus coupler. For notes on the individual circuits in a bus coupler station, please refer to the IL SYS INST UM E user manual (see Section 6.2.3, "Ordering data for documentation").

Housing

The bus coupler is housed in special Inline housing. The connectors and the base can be separated.



For additional information about housing, please refer to the IL SYS INST UM E user manual (see Section 6.2.3, "Ordering data for documentation").

End clamps

Mount end clamps on both sides of the station. The end clamps ensure that the station is correctly mounted. End clamps secure the Inline station on both sides and keep it from moving from side to side on the DIN rail.

Connections

A 9-pos. D-SUB female connector and terminal points for connecting the following cables are available on the PROFIBUS DP/V1 bus coupler:

- PROFIBUS cable for transmitting data to the PROFIBUS system
- Bus coupler supply U_M ; which generates the communications power U_L and the supply for the analog terminals U_{ANA}
- Supply of the I/O supply for the segment circuit U_S
- Functional earth ground (FE)

Connection method

Connect cables with a connection cross-section of 0.2 mm² to 1.5 mm² to the spring-cage connection.

Indicators

The diagnostic and status indicators on the bus coupler and the Inline station indicate the station state, the state of the bus coupler itself, and whether or not the supply voltages are present.

IL PB BK DP/V1

Connection to functional earth ground (FE)

The shield of the PROFIBUS cable is connected to the left FE spring on the bottom of the bus coupler and is therefore connected to the DIN rail.

In addition, U_M , U_S , and GND are coupled capacitively to functional earth ground (FE) in the bus coupler.

Grounding

The bus coupler is grounded when it is snapped onto the grounded DIN rail via the two FE springs, see also "Connecting grounding" on page 2-10.

Required additional grounding

In addition, ground the bus coupler via the FE connection to ensure reliable functional earth grounding of the station even if the FE springs are dirty or damaged. Connect the terminal points for the FE connection to additional grounding (e.g., USLKG 5 universal ground terminal block).

Electrical isolation

For additional information about the various potential areas of the PROFIBUS DP/V1 bus coupler, please refer to the IL SYS INST UM E user manual.

2 From configuration through to startup

2.1 Configuring an Inline station

Configuring an Inline station involves five individual steps:

- Describing and defining the task
- Selecting the required Inline terminals
- Considering the system limits
- Selecting power supplies
- Selecting the PROFIBUS cable

2.1.1 Describing and defining the task

First of all describe your task. For example, it could be as follows:

A production line is to be extended in a brewery. PROFIBUS technology was used in the previous automation system and should also be used in the new system. However, all extensions should be made using Inline terminals. Specify the number and type of I/O signals.

2.1.2 Selecting the required Inline terminals

Select the appropriate Inline terminals for the I/O signals in your project. Not all terminals that can be operated are currently implemented in the PROFIBUS DP/V1 bus coupler firmware and listed in the GSD file.



For a list of devices approved for use on the PROFIBUS DP/V1 bus coupler, please refer to the AH IL BK IO LIST application note, see Section 6.2.1, "Ordering data for the bus coupler".



In general, INTERBUS remote bus branch lines are not permitted.



An end plate, which is supplied as standard with the bus coupler, must be placed at the end of the station. The end plate has no electrical function. It protects the station against ESD pulses and the user against dangerous contact voltages. Each station must be secured by an end clamp at the start and the end of the station (see also the corresponding notes in the "Installation note for electrical personnel" supplied with the bus coupler).



If you wish to set up various electrically isolated areas within a station, you must use additional power terminals that are supplied from separate power supplies.

2.1.3 Considering the system limits

The maximum number of devices that can be connected to a PROFIBUS DP/V1 bus coupler is determined by the basic system specifications: These specifications can be found in "Number of devices" on page 1-8.



Observe the current consumption of each device on the individual potential jumpers when configuring an Inline station. This data can be found in the relevant terminal-specific data sheet.



For additional information about the address area of I/O terminals on the PROFIBUS coupler, please refer to the AH IL PB BK DP/V1 (PAC) address area application note, see Section 6.2, "Ordering data".

2.1.4 Selecting power supplies



For information about the individual circuits within an Inline station, please refer to "Circuits and provision of supply voltages" on page 2-12.

The selection of suitable power supplies always depends on the individual system. 24 V DC power supplies should, however, always meet the following criteria:

Nominal value:	24 V DC
Tolerance:	-15%/+20% (according to EN 61131-2)
Ripple	±5%
Permissible range:	19.2 V to 30 V (ripple included)



A selection of suitable power supplies can be found in the Phoenix Contact "INTERFACE" catalog.

2.1.5 Selecting the PROFIBUS cable



For interference-free transmission, Phoenix Contact recommends a 2-wire, twisted pair and shielded cable, specified as cable type A in EN 50170-8-2. Cable type B, which is also described, should no longer be used as it is out of date.

Installing the PROFIBUS cable

When installing the PROFIBUS cable, note the following:

- Do not install signal and bus cables parallel to power cables or in bundles with power cables.
- Install PROFIBUS cables and cables with direct voltages > 60 V and alternating voltages > 25 V in separate bundles or cable ducts.
- Always install signal cables and equipotential bonding together in one channel, along the shortest route.
- Avoid extending the PROFIBUS cables with connectors.
- Do not install PROFIBUS cables in bundles with telephone lines and cables leading to potentially explosive areas.
- As a rule, avoid branch lines.

2.2 Installing and connecting a PROFIBUS DP/V1 bus coupler station

2.2.1 Safety notes



WARNUNG: Dangerous contact voltage

When using terminals outside the SELV area, please observe all the information provided in the "Important information about voltage areas" section of the IL SYS INST UM E user manual (see Section 6.2.3, "Ordering data for documentation").

When using Inline terminals in the **SELV** area:



ACHTUNG: Disregarding this warning may result in malfunction

Do not replace terminals while the power is connected.

Before removing or mounting a terminal, disconnect power to the entire station.

Make sure the entire station is reassembled before switching the power back on.

When using Inline terminals in the **low voltage** area:



WARNUNG: Dangerous contact voltage

Do not replace terminals while the power is connected.

Before removing or mounting a terminal, disconnect power to the entire station.

Make sure the entire station is reassembled before switching the power back on.

2.2.2 Installation notes



With prewired terminals, check that the electronics base, the connectors, and the connecting cables are installed correctly.



For information about installing and wiring Inline terminals, sensors, and actuators, please refer to the terminal-specific data sheets and the IL SYS INST UM E user manual (see Section 6.2.3, "Ordering data for documentation").

2.2.3 Structure of an Inline station with a PROFIBUS DP/V1 bus coupler

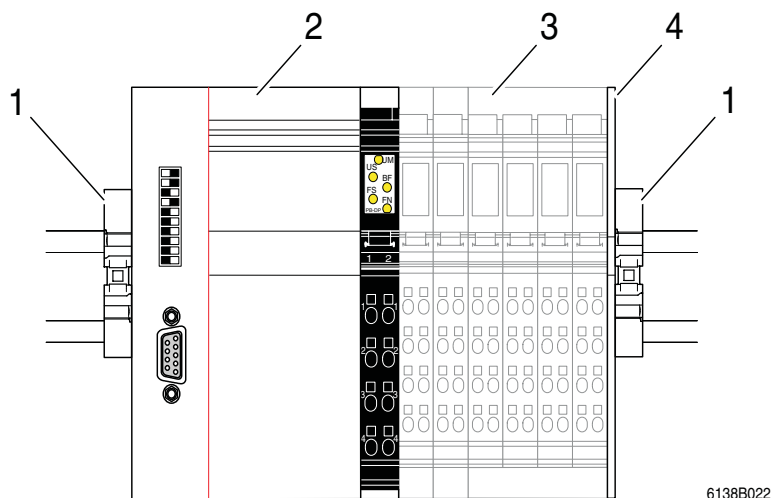

6138B022

Figure 2-1 Structure of an Inline station with a PROFIBUS DP/V1 bus coupler

To ensure reliable operation, an Inline station with a PROFIBUS DP/V1 bus coupler **must** consist of the following elements:

- 1 End clamps
- 2 PROFIBUS DP/V1 bus coupler
- 3 Terminals appropriate to the application
- 4 End plate (supplied as standard with the bus coupler)



For additional information about installation and removal, please refer to the IL SYS INST UM E user manual (see Section 6.2.3, "Ordering data for documentation").

2.2.4 General tips and notes on setting up the PROFIBUS DP/V1 bus coupler station

Order of the Inline terminals

The order of the terminals within a station should depend on the current consumption of the I/O devices from the potential jumpers U_M and U_S .

As the voltage at every power terminal is reinjected into the potential jumpers U_M and U_S , the section (main circuit) between a bus coupler and a power terminal or between a power terminal and the next power terminal must always be considered when calculating the current. If power terminals are not used, the entire station is a main circuit.

Within a main circuit, install the terminals according to their current consumption. Install the terminals with the highest current consumption first. This has the advantage that the high supply current does not flow through the entire main circuit and thus does not flow through all the terminals.

For a table listing the recommended order of the terminals, please refer to the IL SYS INST UM E user manual (see Section 6.2.3, "Ordering data for documentation").



Observe the current consumption of the terminals. This data can be found in the relevant terminal-specific data sheet.

Please refer to the terminal-specific data sheets for changes to the current carrying capacity or to the possible output currents (derating).



When using terminals for analog signals, please observe the following:

High current flowing through potential jumpers U_M and U_S leads to a temperature rise in the potential jumpers and inside the terminal. This reduces the measuring accuracy and shortens the service life of the terminal.

To keep the current flowing through the potential jumpers of the analog terminals as low as possible, always place the analog terminals after all the other terminals at the end of the main circuit.

Within the analog terminals, position the IB IL TEMP 2/UTH-PAC terminal after **all** the other terminals to keep the current flowing through **all** the potential jumpers as low as possible.

2.2.5 Connecting the PROFIBUS DP/V1 bus coupler

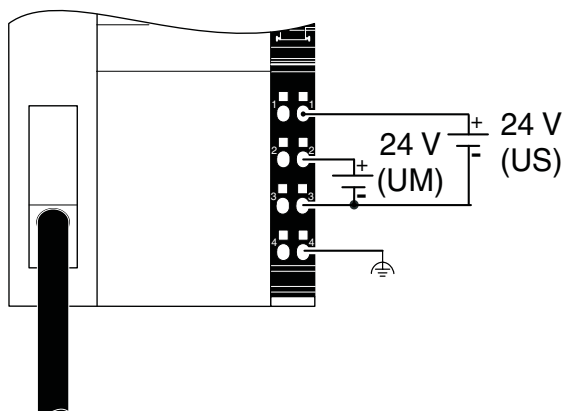

PROFIBUS-DP

6137B007

Figure 2-2 Circuit diagram for the PROFIBUS DP/V1 bus coupler

Connect the supply voltages to the bus coupler according to Figure 2-2. For the terminal point assignment of the bus coupler, please refer to Figure 2-3 and Table 2-1.

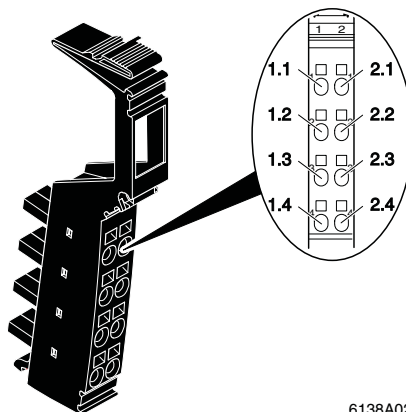

6138A027

Figure 2-3 PROFIBUS DP/V1 bus coupler terminals

Table 2-1 Assignment of the bus coupler terminal points

Terminal points	Remark
1.1, 2.1	Segment supply U_S (+24 V DC)
1.2, 2.2	Main supply, bus coupler supply, communications power, and interface supply U_M (+24 V DC)
1.3, 2.3	Reference potential GND
1.4, 2.4	Functional earth ground (FE)

The analog voltage U_{ANA} , which is generated from the main voltage, can carry a current of 0.5 A. The communications power U_L , which is also generated from the main voltage, can carry a current of 2.0 A.

2.2.6 Securing cables

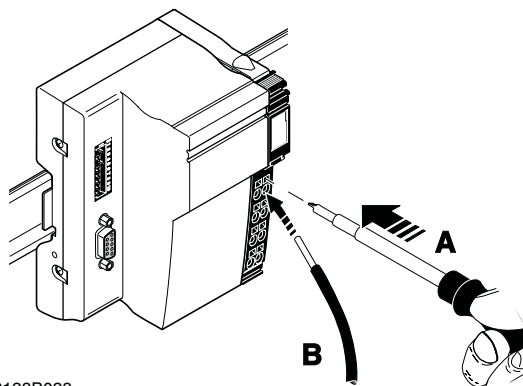

6138B028

Figure 2-4 Securing cables

- Release the spring by pressing with the screwdriver (A).
- Insert the 8 mm stripped cable in the terminal point (B).
- Secure the cable by removing the screwdriver.

2.2.7 Connecting PROFIBUS

Observe the following parameters when connecting the cables:

Table 2-2 PROFIBUS cable parameters

Parameter	Cable type A
Characteristic wave impedance in Ω	135 to 165 (at a frequency of 3 MHz to 20 MHz)
Effective capacitance (pF/m)	≤ 30
Loop resistance (Ω /km)	≤ 110
Conductor diameter (mm)	> 0.64 *)
Conductor cross-section (mm ²)	> 0.34 *)

*) Observe the permissible conductor cross-sections of the PROFIBUS connector used.

Switch on the termination resistors for the last device in the PROFIBUS connector.

For higher baud rates (> 1.5 Mbaud) use connectors with integrated series inductances.



Install the cable shield in the PROFIBUS connector. Phoenix Contact recommends using the SUBCON-PLUS-PROFIB connector to connect PROFIBUS.

When installing the bus coupler in the cabinet, connect the cable shield of the connected PROFIBUS cable to a shield bus directly after the cable feed-through via cable clamps. Use an appropriate shield connection clamp for this. Phoenix Contact recommends using the SK 8 shield connection clamp with the corresponding accessories. For additional information, please refer to the Phoenix Contact "CLIPLINE" catalog.

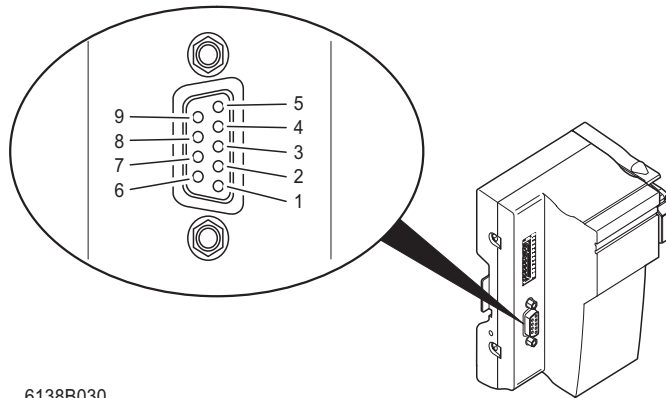

6138B030

Figure 2-5 Pin assignment of the 9-pos. D-SUB female connector

Connect PROFIBUS to the bus coupler via a 9-pos. D-SUB connector (e.g., SUBCON-PLUS-PRO-FIB). Please refer to the pin assignment in the following table.

Table 2-3 PROFIBUS interface:
Pin assignment of the 9-pos. D-SUB female connector

Pin	Assignment
1	Reserved
2	Reserved
3	RxD/TxD-P (receive/transmit data +), cable B
4	CNTR-P (control signal for repeater), direction control
5	DGND (reference potential to 5 V)
6	VP (+5 V supply voltage for termination resistors)
7	Reserved
8	RxD/TxD-N (receive/transmit data -), cable A
9	Reserved

2.2.8 Connecting grounding

The bus coupler is grounded when it is snapped on by means of the FE spring (metal clip) on the bottom of the electronics base. This spring establishes an electrical connection to the DIN rail. To ensure reliable grounding even when the DIN rail is dirty or the metal clip has been damaged, Phoenix Contact also recommends securing the bus coupler on the DIN rail with an end clamp over the left-hand housing latch and grounding it via the FE connections of the power connector (e.g., with the USLKG 5 universal ground terminal block, see Figure 2-6). The recommended ground terminal block can also be used to secure the bus terminal, see also Figure 2-6.

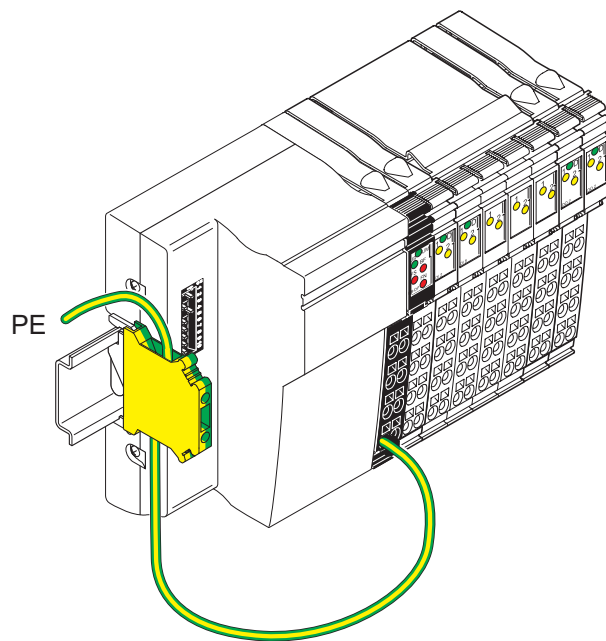

6138C011

Figure 2-6 Additional grounding of the PROFIBUS DP/V1 bus coupler



For additional information about the grounding concept of an Inline station, please refer to the IL SYS INST UM E user manual (see Section 6.2.3, "Ordering data for documentation").

2.3 Supply at the PROFIBUS DP/V1 bus coupler

The main voltage U_M and the segment voltage U_S **must** be connected at the PROFIBUS DP/V1 bus coupler. The voltages for the logic circuit U_L and the supply of the terminals for analog signals U_{ANA} are internally generated from the main voltage. The segment voltage is used to supply the sensors and actuators.

In the simplest case, all the required 24 V supply voltages can be supplied at the bus coupler. The entire station is supplied with power from the bus coupler (see "Installing and connecting a PROFIBUS DP/V1 bus coupler station" on page 2-4). In this case, the following supply voltages must be supplied or provided:

U_M

24 V supply in the main circuit

The main voltage U_M supplies all of the devices connected to the main circuit. It also supplies the bus coupler, the communications power U_L , and the analog voltage U_{ANA} .

U_S

24 V supply in the segment circuit

The segment voltage U_S can be supplied separately at the bus coupler or tapped from the main circuit. Install a jumper or create a segment circuit using a switch to tap the voltage U_S from the main circuit U_M .

The voltage U_S supplies all of the devices connected to the segment circuit.

Electrical isolation: PROFIBUS DP

The PROFIBUS interface is electrically isolated from the bus coupler logic. The PROFIBUS cable shield is directly connected to the functional earth ground spring (FE spring), which is located on the left-hand side directly below the D-SUB female connector on the bottom of the bus coupler. This spring is not connected to the second FE spring in the module, which is located on the right-hand side on the bottom, directly below the terminal points. The right spring is connected directly to both terminal points of the power connector. When the two FE springs have been snapped on, they make contact with the DIN rail and are used to discharge interference, rather than serve as protective earth ground. To ensure effective interference discharge, even for dirty DIN rails, connect functional earth ground directly to terminal points 1.4 or 2.4. This also grounds the Inline station sufficiently up to the first segment terminal.

To prevent the flow of compensating currents, which may affect data transmission quality, connect a suitably sized equipotential bonding cable parallel to the PROFIBUS cable.

Electrical isolation: I/O

The bus coupler does not have electrical isolation for the communications power of the I/O terminals. U_M (24 V), U_L (7.5 V), and U_{ANA} (24 V) are not electrically isolated.

It is only possible to isolate both voltages separately using separate supply options for the main voltage U_M and the I/O voltage U_S on the bus coupler, as both voltages have the same ground reference. To electrically isolate both voltages, a separate power terminal must be used. Only then can it be ensured that the electrical isolation in the input and output terminals cannot be jumpered by a common ground reference.

2.4 Electrical potential and data routing

2.4.1 Circuits and provision of supply voltages

There are several circuits within an Inline station. These are automatically created when the terminals are properly installed. The voltages of the different circuits are supplied to the connected terminals via potential jumpers.

An example of the circuits within a station is provided on the next page.

Load capacity of the jumper contacts

Observe the maximum current carrying capacity of the jumper contacts on the side for each circuit.

The connection of the supply voltages is described in "Selecting power supplies" on page 2-2.



Please also observe the notes on current carrying capacity and voltage connection in the terminal-specific data sheets.



For additional information about the provision of the supply voltage, please refer to the IL SYS INST UM E user manual.

2.4.2 Example of a circuit diagram

Figure 4-1 shows a typical circuit diagram. Its segments are described below.

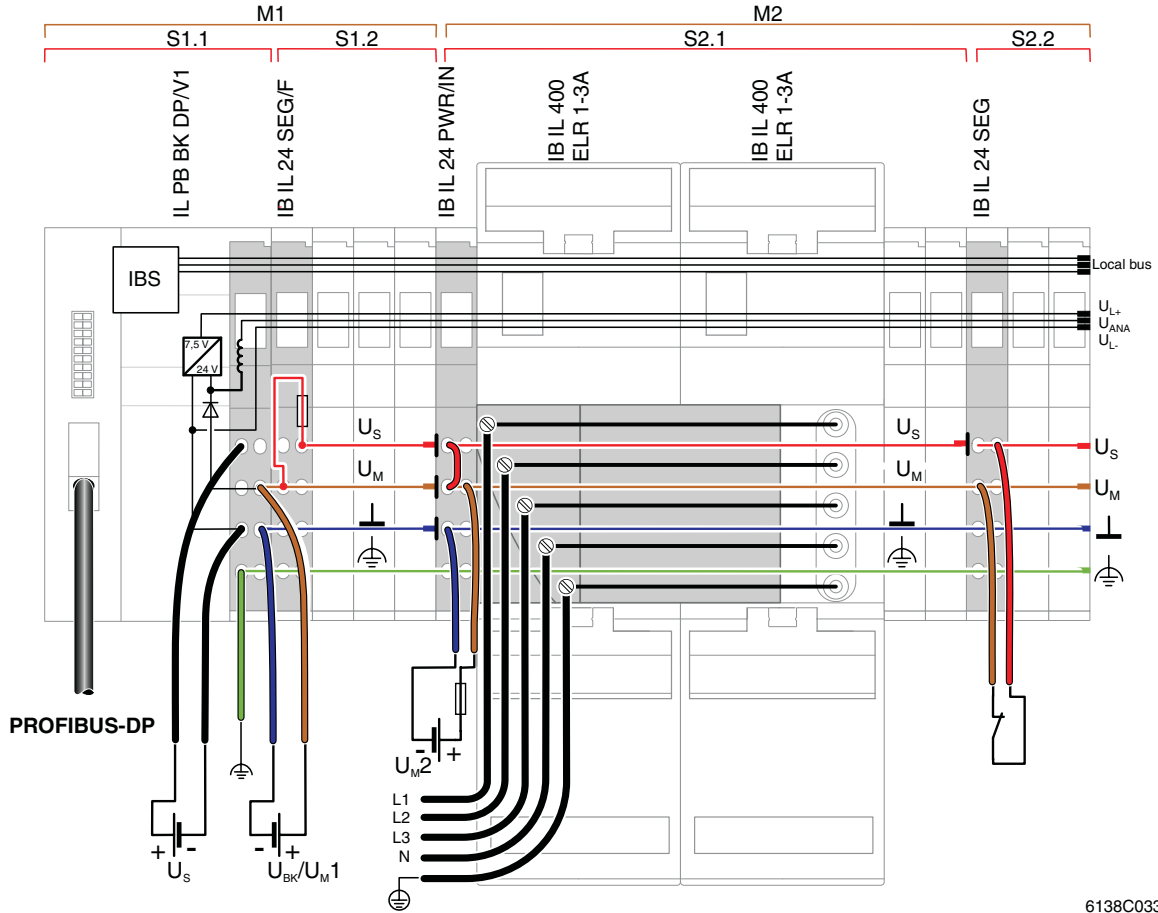

6138C033

Figure 2-7 Circuit diagram for the PROFIBUS DP/V1 bus coupler

- Mx** Main circuit (e.g., M1, M2)
- Sx.y** Segment circuit y in main circuit x (e.g., S2.1, S2.2)
- BK** PROFIBUS DP/V1 bus coupler
- U_{BK}** Bus coupler supply (supply for bus coupler, generates U_{ANA} and U_L)
- U_M** Main supply (I/O supply in the main circuit)
- U_S** Segment supply (I/O supply in the segment circuit)
- U_{ANA}** I/O supply for analog terminals
- U_L** Communications power

IL PB BK DP/V1

Main circuit M1/	The supply voltage for the bus coupler and the main and segment voltage are supplied in the PROFIBUS DP/V1 bus coupler.
Segment S1.1	The communications power U_L and the supply voltage of the analog terminals U_{ANA} are generated from the PROFIBUS DP/V1 bus coupler supply and led through the entire station. No terminals are used in segment S1.1.
Segment S1.2	In a segment terminal with fuse, the segment voltage U_S for segment S1.2 is automatically tapped from the main voltage U_M1 . This segment circuit is protected by the internal fuse. This segment terminal has been specifically used to create a protected segment circuit without the need for an additional external fuse. If this is not necessary, the terminal does not have to be used. In this case, the connection between U_M and U_S on the bus coupler must be established using a jumper (as shown on the IB IL 24 PWR/IN terminal) or a switch (as shown on the IB IL 24 SEG terminal).
Main circuit M2/ segment S2.1	The supply voltage for the power-level terminals and the subsequent terminals should be supplied separately. For this, a new power terminal (e.g., IB IL 24 PWR/IN) is used, which supplies the supply voltage U_M2 . Using a jumper, the segment voltage U_S for segment S2.1 is tapped from the main voltage U_M2 at this terminal.
Segment S2.2	The segment voltage U_S is provided at the IB IL 24 SEG segment terminal via a switch. Output terminals installed here can therefore be switched externally.

Examples of errors and their effects:

In this example structure, a short circuit in segment S1.2 would not affect the terminals in other segments. The fuse in the IB IL 24 SEG/F segment terminal means that only segment S1.2 is switched off.

2.5 Connecting Inline terminals

Finally, connect all the Inline terminals.



For information about the I/O terminals, sensors, and actuators, please refer to the IL SYS INST UM E user manual and the terminal-specific data sheets (see Section 6.2.3, "Ordering data for documentation").

2.6 Diagnostics on the PROFIBUS DP/V1 bus coupler

Diagnostics are provided locally by LEDs on the bus coupler, as well as on the Inline terminals and FLM branch terminals. Diagnostic information is also forwarded to the PROFIBUS master via PROFIBUS DP.

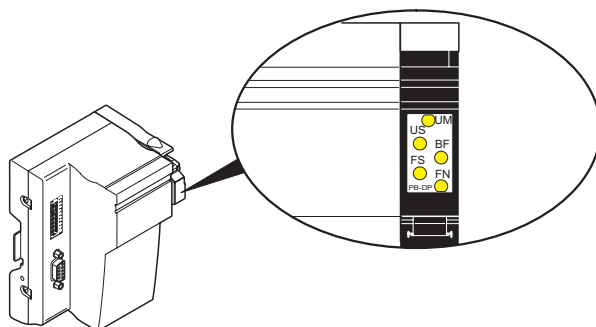

6138B021

Figure 2-8 Indicators on the PROFIBUS DP/V1 bus coupler

The following states can be read on the PROFIBUS DP/V1 bus coupler:

Table 2-4 Diagnostic LEDs of the PROFIBUS DP/V1 bus coupler

LED	Color	Meaning	State	Description of the LED states
UM	Green	U _{Main}	ON	24 V main circuit supply present.
			OFF	Main circuit supply not present.
US	Green	U _{Segment}	ON	24 V segment circuit supply present.
			OFF	Segment circuit supply not present.
BF	Red	Bus Fault	ON	No communication on PROFIBUS.
			OFF	No error.
FS	Red	Failsafe	Flashing	PLC in STOP state. Failsafe values are output.
			ON	If FS is on, FN indicates the error type.
			OFF	If FS is not on, FN indicates the error number.
FN	Red	Failure Number	Flashing	The number of flashing pulses indicates the error type or the error number, depending on whether FS is on or not



For additional information about the individual error codes, please refer to "Error description" on page A-1.

2.7 Configuration and startup of the Inline station on PROFIBUS

2.7.1 Hardware configuration

Configure the hardware on the PROFIBUS DP/V1 bus coupler using the 10-pos. DIP switch.

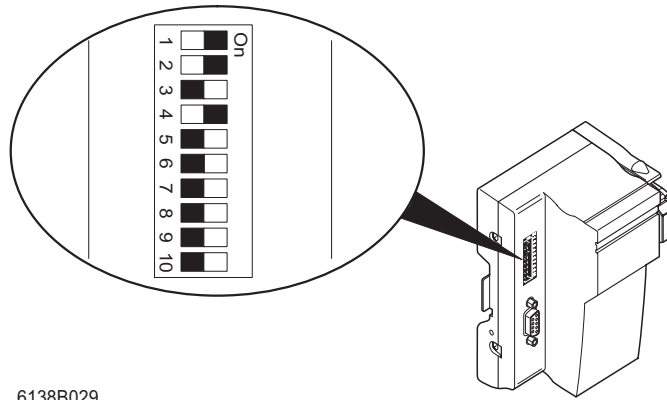

6138B029

Figure 2-9 DIP switches on the PROFIBUS DP/V1 bus coupler

The PROFIBUS address and other PROFIBUS DP/V1 bus coupler settings can be set using the 10-pos. DIP switch. For the meaning of the switches, please refer to Table 2-5.

Table 2-5 DIP switch settings on the bus coupler

DIP switch	Meaning
1 to 7	PROFIBUS address in binary representation (= 0 - 127 in decimal representation) Switch 1 specifies the least significant bit (2^0) Switch 7 specifies the most significant bit (2^6)
8	Inline station operating mode: ON = New mode with DP/V1 support, safety values, and parameterization OFF = Compatible mode (to IL PB BK)
9 to 10	Reserved, both switches must be in the OFF position

2.7.2 Mains termination resistors

Since PROFIBUS is a serial bus system in a star/tree structure, the individual branches must be terminated with a termination resistor. The PROFIBUS DP/V1 bus coupler does not have a resistor of this type. For additional information, please refer to the PROFIBUS documentation. Phoenix Contact recommends using the SUBCON-PLUS-PROFIB PROFIBUS connector. This connector has a termination resistor that can be connected.

2.7.3 Configuration and startup using the STEP 7[®] SIMATIC[®] Manager

This section describes configuration and startup using the STEP 7[®] SIMATIC[®] Manager software (English Version 5.1 + Service Pack 3, Release K5.1.3.0). You can apply the procedures to other similar software.

Requirements

- PROFIBUS network is installed
- Termination resistors are specified
- PROFIBUS addresses on the device are set
- Baud rate is specified



If Inline or FLM devices with a data width of less than 5 bits and with the same ID and length code are connected next to each other, they are automatically packed during autoconfiguration, i.e., their data is combined. If you carry out the configuration yourself using a hardware configurator, e.g., the Siemens STEP 7[®] SIMATIC[®] Manager, the automatic configuration in the station is overwritten.

IL PB BK DP/V1

**Starting the STEP 7®
SIMATIC® Manager**

Start the STEP 7® SIMATIC® Manager under Windows.

**Creating a new
project**

Call the "New" dialog box using the "File... New" menu item. Enter the desired name. In this example, the name "Example" has been chosen. If necessary, change the project type and storage location.

Confirm the entry with "OK".

The "Example" project is created.

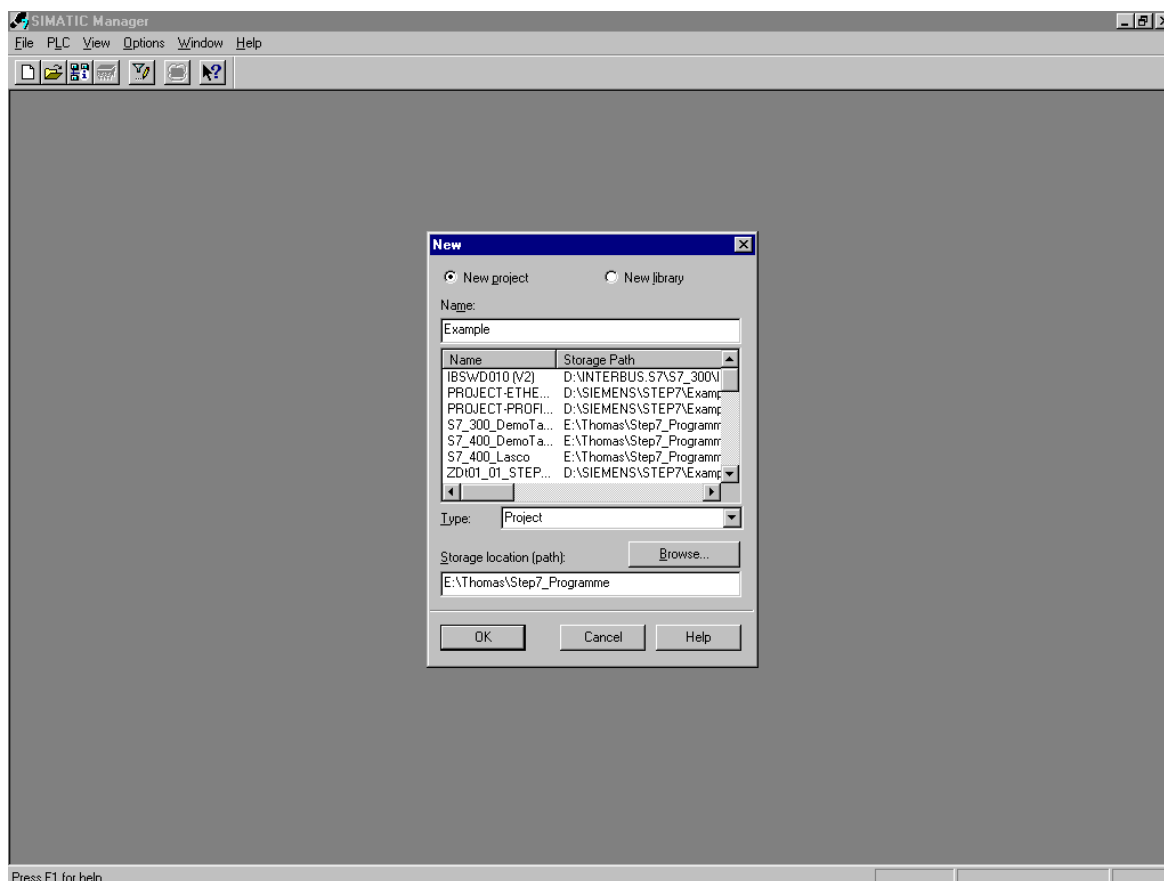

Figure 2-10 Creating a new project

Inserting a new SIMATIC® S7® station in the project

Insert a station using the "Insert... Station... SIMATIC® 300 Station" menu item. In this example, a "SIMATIC® 300 Station" has been selected.

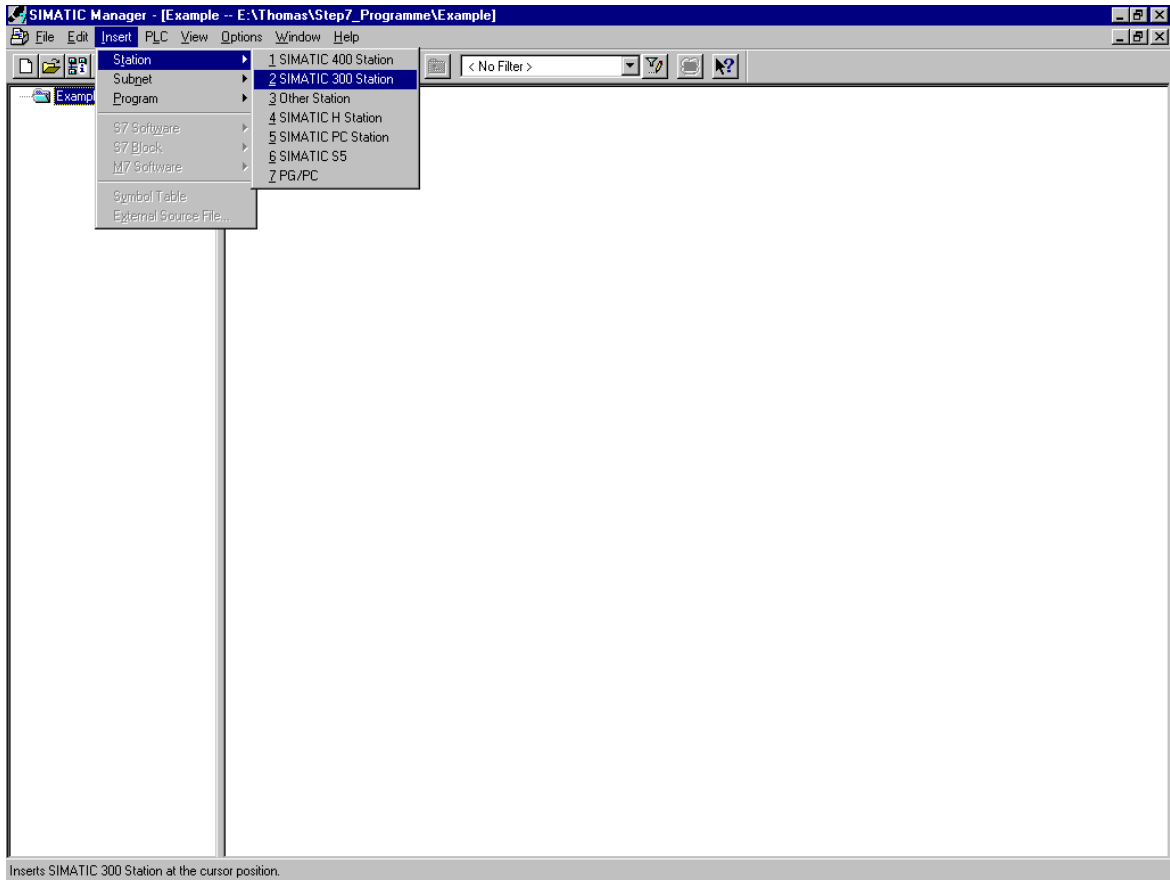

Figure 2-11 Inserting a new SIMATIC® S7® station in the project

IL PB BK DP/V1

On the left-hand side of the project window, click on the small "plus" box next to the "Example" folder and select "SIMATIC® 300(1)".

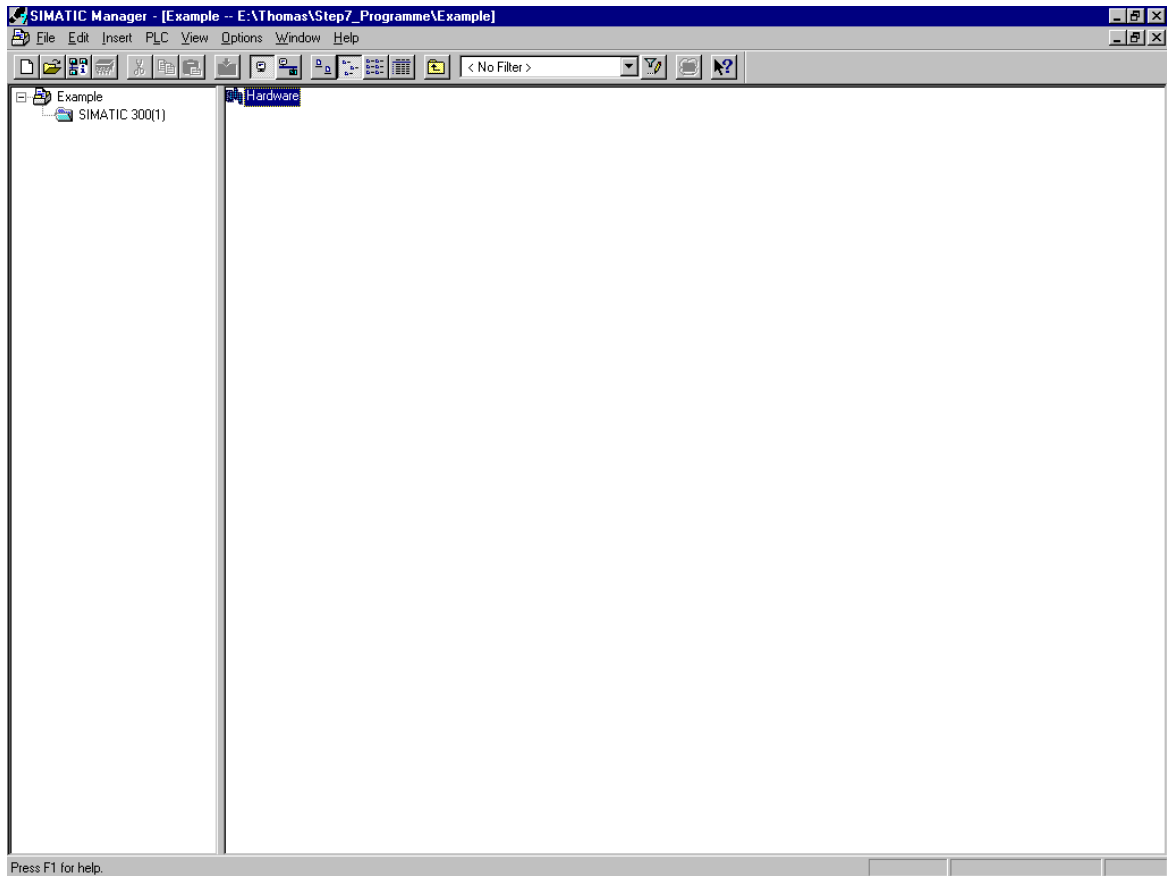

Figure 2-12 Selecting SIMATIC® 300(1)

The SIMATIC® Manager displays the "Hardware" object in the right-hand window.

Double-click on "Hardware" to start the hardware configurator, which can be used to edit the configuration table.

From configuration through to startup

Installing a new GSD file

The characteristic communication features of a PROFIBUS device are defined in the form of an electronic device data sheet (GSD, device master data file).

If you do not know which GSD file to use or if it is not available, it can be downloaded from the Download Center of Phoenix Contact GmbH & Co. KG.



The required bus coupler GSD file is available at www.download.phoenixcontact.com.

Save the ZIP file to a corresponding directory and extract the file.

Open the "PXC_00F0.gsd" and "PXC_06CC.gsd" files via "Options... Install New GSD Files..." in the dialog box that appears.

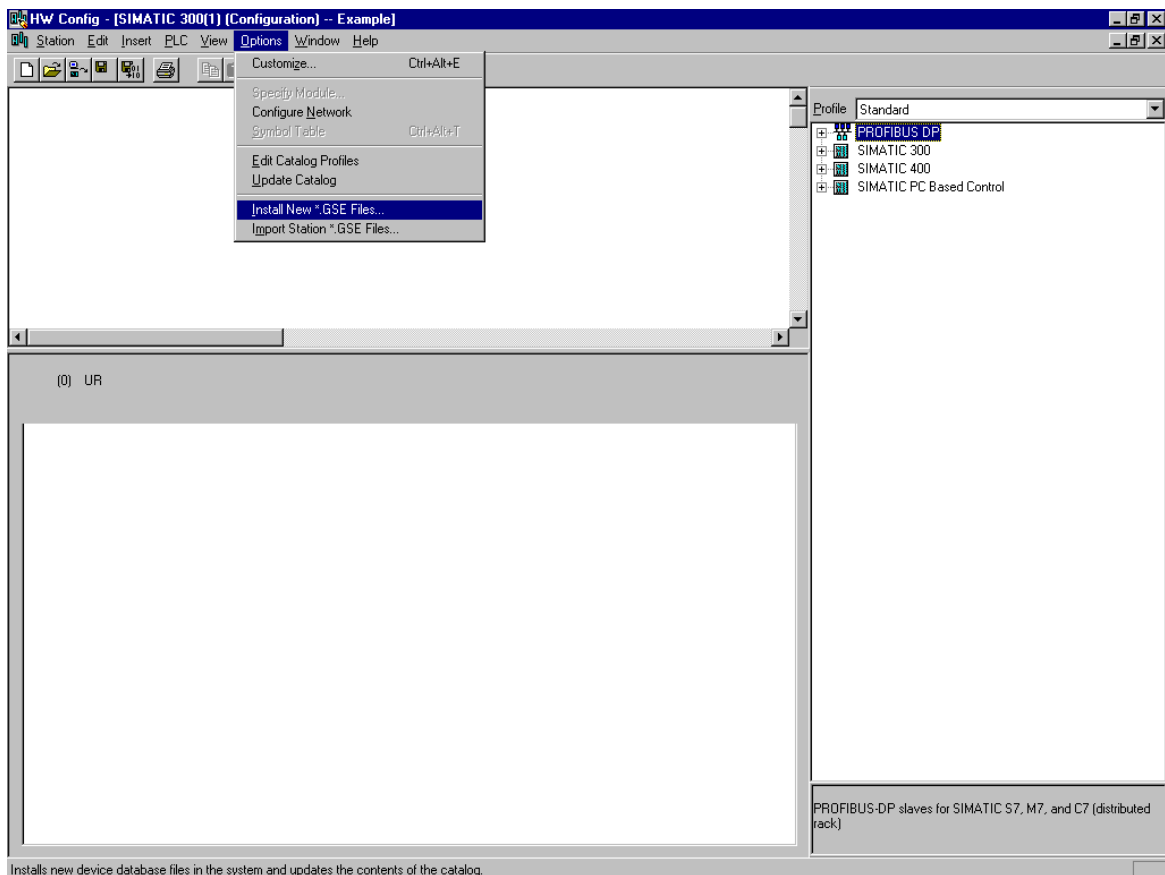

Figure 2-13 Installing a new GSD file

The new GSD file is loaded in the corresponding directory and the hardware catalog is updated. The icon for the PROFIBUS DP/V1 bus coupler is installed at the same time.

Selecting the DIN rail and power supply unit

Now select the DIN rail and the power supply unit.

For the corresponding procedure, please refer to your STEP 7® SIMATIC® Manager user manual.

IL PB BK DP/V1

Selecting the CPU

Now select the CPU by double-clicking on the CPU folder in the right-hand window (1): "CPU 315-2DP" in this example.

Click on "New" in the "Properties - PROFIBUS interface DP Master (R0/S2.1)" window (2).

Enter the name ("PROFIBUS(1)") in the "Properties - New subnet PROFIBUS" dialog box (3), and confirm the entry with "OK" or "Return".

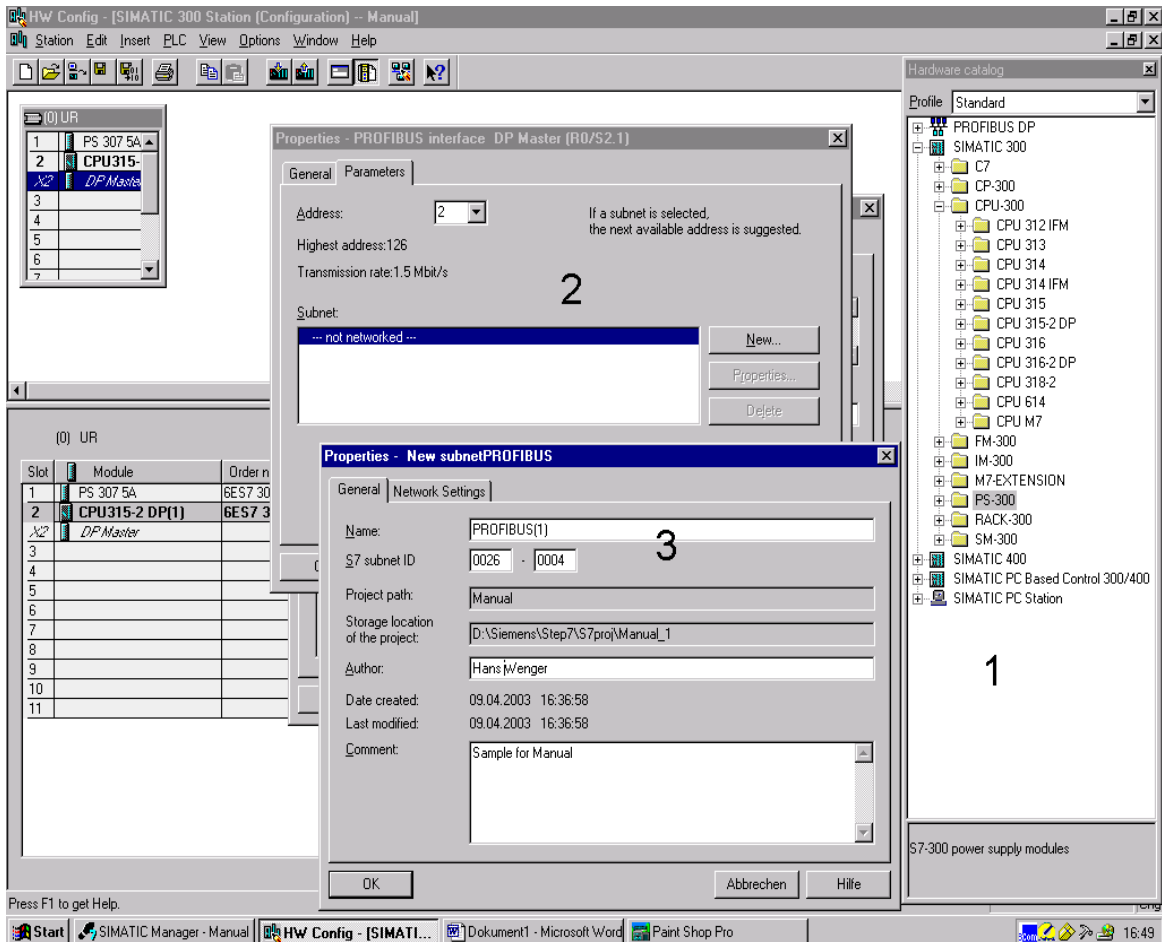

Figure 2-14 Selecting the CPU

From configuration through to startup

Next confirm the entries in the "Properties - PROFIBUS interface DP Master (R0/S2.1)" window with "OK" or "Return".

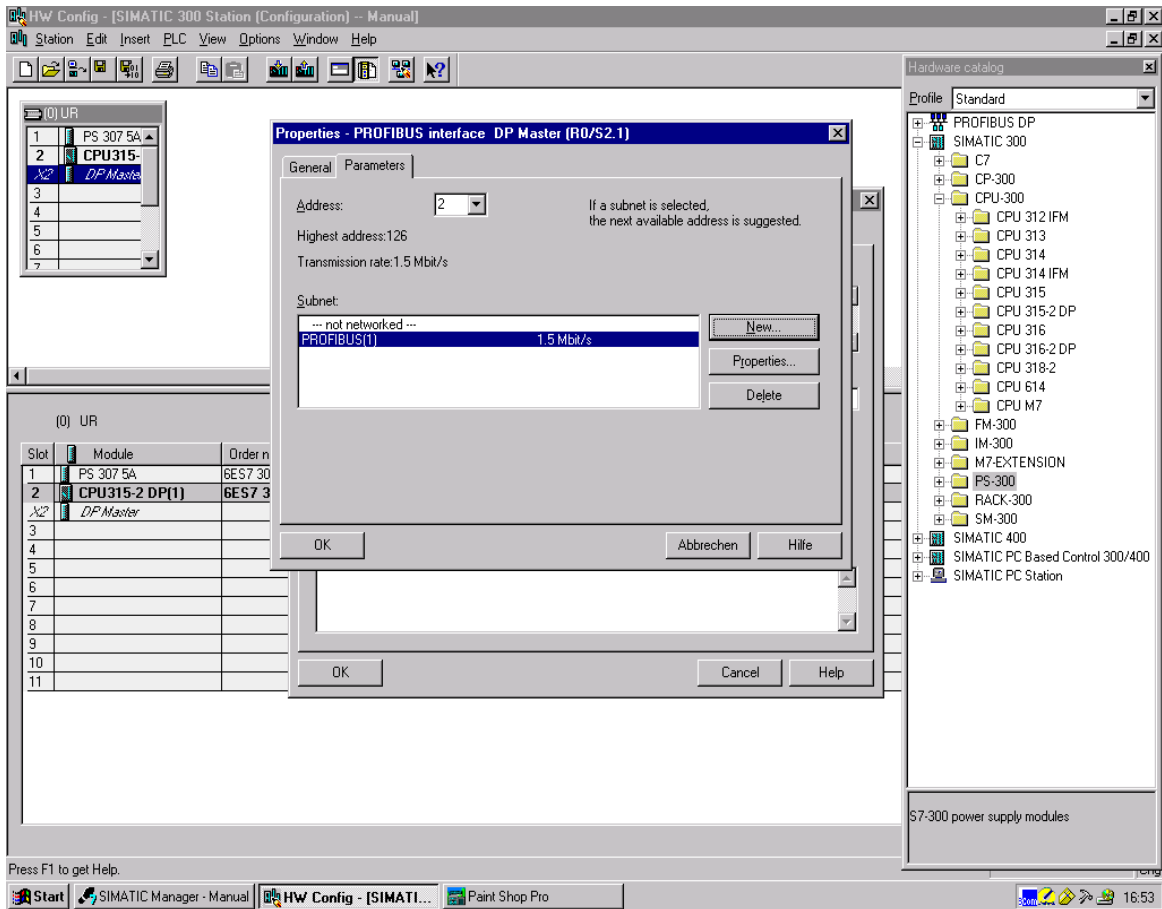

Figure 2-15 Properties - PROFIBUS interface DP Master (R0/S2.1)

IL PB BK DP/V1

Selecting the PROFIBUS DP/V1 bus coupler

Click on "PROFIBUS(1): DP master system (1)" (1).

Click in the free slot (2).

Select the PROFIBUS DP/V1 bus coupler from the hardware catalog (3) in the "PROFIBUS DP... Additional Field Devices... I/O... Phoenix Contact GmbH & Co KG... Inline... IL PB BK DP/V1 (DIP8 = 0N)" menu item by double-clicking on "IL PB BK DP/V1(DIP8 = 0N)".

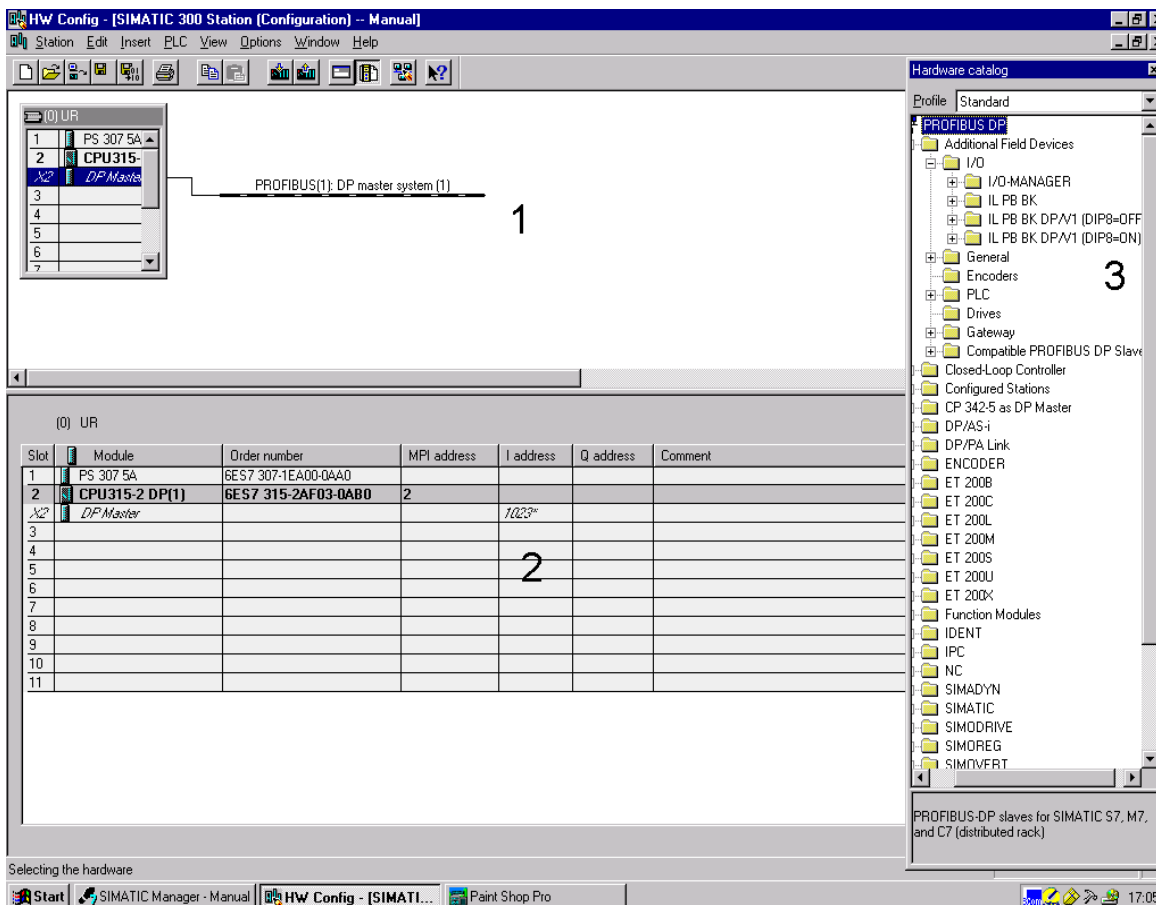

Figure 2-16 Selecting the PROFIBUS DP/V1 bus coupler

From configuration through to startup

The "Properties - PROFIBUS interface IL PB BK DP/V1" window opens.

Check the PROFIBUS address of the bus coupler in the dialog box that opens, and if necessary, modify it according to the application. Confirm your entries with "OK".

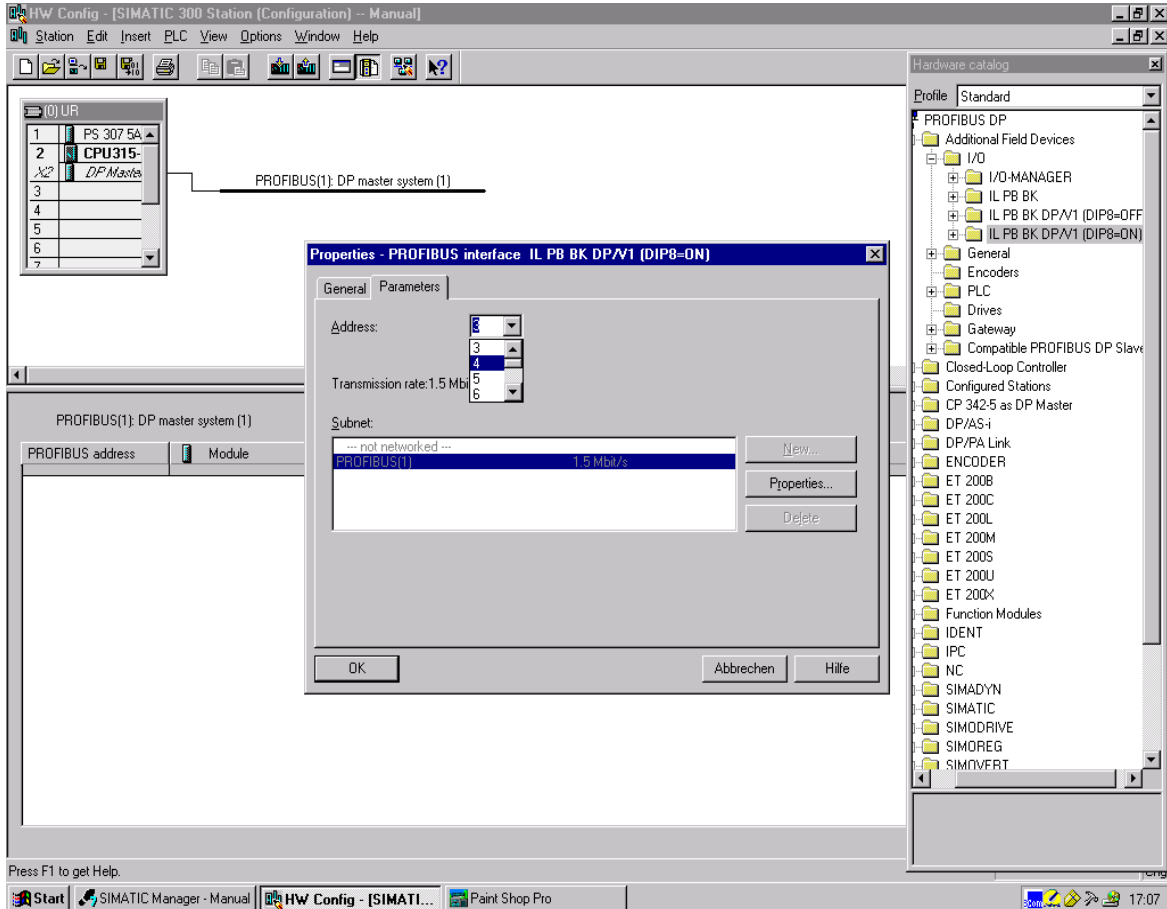

Figure 2-17 Properties - PROFIBUS interface

IL PB BK DP/V1

Positioning the bus coupler

- Select the bus coupler by clicking on the bus coupler icon (1).
- Select a free slot by clicking in a free slot/row (2).

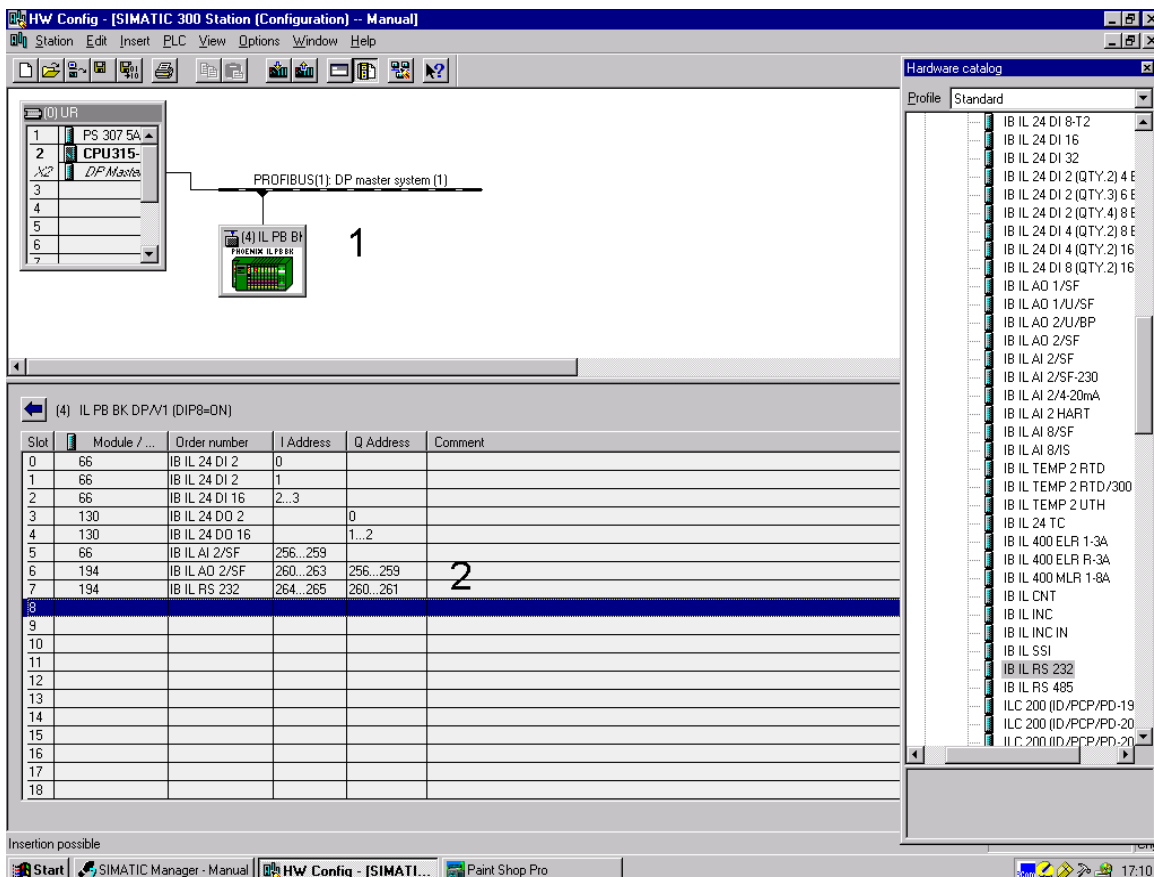

Figure 2-18 Positioning the bus coupler

The Inline components and FLM branch terminals can now be selected from the hardware catalog and assigned to the bus coupler according to their physical position in the sequence (drag & drop).



Passive devices, e.g., power terminals or the FLM branch terminal (IB IL 24 FLM-PAC), do not need to be configured. However, power terminals with diagnostic functions or segment terminals with diagnostic functions must be configured in the station.

From configuration through to startup

If necessary, the I/O addresses can be modified by double-clicking on the row for the Inline and FLM components. Entries can be made in the "Properties - DP slave" dialog box that opens. Confirm your entries with "OK" or "Return".

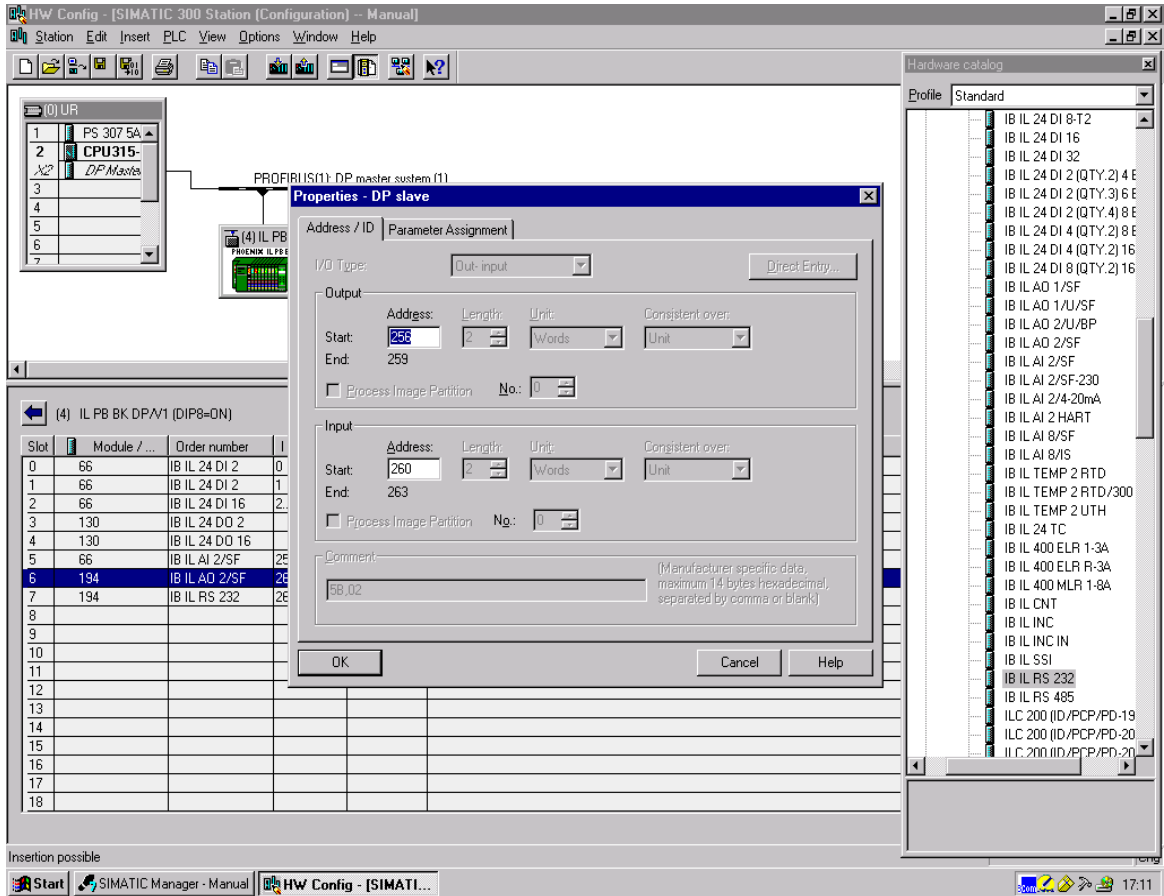

Figure 2-19 Checking or modifying I/O addresses

IL PB BK DP/V1

Additional PROFIBUS DP devices can be connected to the DP master system - in this case "PROFIBUS(1)" - and parameterized and addressed according to the device type.

The screenshot shows the HW Config interface for a SIMATIC 300 station. The main window displays a PROFIBUS DP master system (1) connected to five slave modules. The hardware catalog on the right shows the selected modules. Below the diagram is a table with the following data:

PROFIBUS address	Module	Order number	Diagnostic address	Comment
4	IL PB BK DP/V1 (DIP)		1022	
5	IL PB BK DP/V1 (DIP)		1021	
6	IM151-1	6ES7 151-1AA01-0A80	1020	
7	FLS PB M12 DI 16 M1		1019	
8	ILB PB 24		1018	ILB PB 24 DI16 DO16

Figure 2-20 Connecting additional devices to the DP master system

From configuration through to startup

Transfer to the S7 system Save and translate the project by clicking on  or using the "Station... Save and Translate" menu item.

Transfer the project to the S7 system by clicking on  or using the "Target System... Load to Module" menu item.

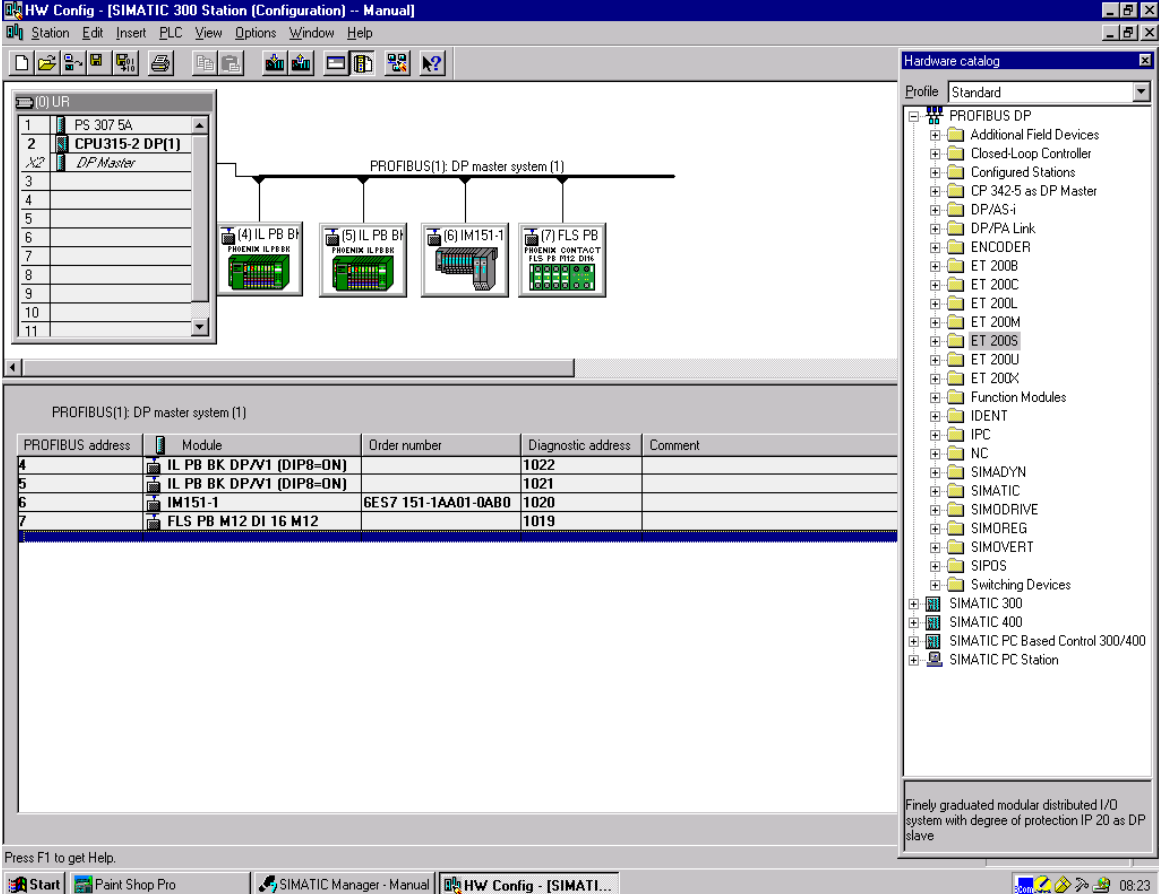

Hardware catalog

Profile: Standard

PROFIBUS DP

- Additional Field Devices
- Closed-Loop Controller
- Configured Stations
- CP 342-5 as DP Master
- DP/AS-i
- DP/PA Link
- ENCODER
- ET 200B
- ET 200C
- ET 200L
- ET 200M
- ET 200S
- ET 200U
- ET 200X
- Function Modules
- IDENT
- IPC
- NC
- SIMADYN
- SIMATIC
- SIMODRIVE
- SIMOREG
- SIMOVERT
- SIPOS
- Switching Devices
- SIMATIC 300
- SIMATIC 400
- SIMATIC PC Based Control 300/400
- SIMATIC PC Station

PROFIBUS(1): DP master system (1)

PROFIBUS address	Module	Order number	Diagnostic address	Comment
4	IL PB BK DP/A1 (DIP8=ON)		1022	
5	IL PB BK DP/A1 (DIP8=ON)		1021	
6	IM151-1	6ES7 151-1AA01-0AB0	1020	
7	FLS PB M12 DI 16 M12		1019	

Press F1 to get Help.

Start | Paint Shop Pro | SIMATIC Manager - Manual | HW Config - [SIMATI... | 08:23

Finely graduated modular distributed I/O system with degree of protection IP 20 as DP slave

Figure 2-21 Transfer to the S7 system

After data transmission is complete, the PROFIBUS system starts automatically.

2.7.4 Selecting parameters

In this case, parameterization refers to setting the options on an I/O terminal and specifying failsafe values. For example, for an analog input terminal, this involves setting the measuring range: 0 mA to 20 mA or 4 mA to 20 mA. For an analog output terminal, this may involve specifying a failsafe value of, e.g., 3 V or "Hold". In addition to the parameters that can be set for I/O terminals, the bus coupler itself also has different setting options.

The parameterization of I/O terminals is very extensive. It ranges from setting the measuring range and the filter depth for analog inputs through selecting temperature sensors to safety values for digital and analog outputs.

Function terminals, such as counter and absolute encoder terminals, also have a wide range of different setting options, which can be individually adjusted according to the application. For this reason it is also possible to carry out parameterization from the application, e.g., using function blocks.

Typically, parameterization is carried out by the C1 master on slave startup. It can also be carried out by acyclic services.

The format of the parameter telegram is as follows (see also "Format of the parameter telegram" on page A-6):

Table 2-6 Format of the parameter telegram

Bytes 1 to 7	DP standard
Bytes 8 to 10	DP/V1 standard
Byte 11	Bus coupler parameter byte

Table 2-7 Format of the I/O terminal

Byte 1	Parameter byte/safety value/configuration value/PCP
Byte 2 onwards	Configuration block
	Failsafe value
	PCP block

Usually, you need only import the GSD file and update the device directory. When a terminal that can be parameterized is selected, most hardware configuration tools display a dialog box, in which all the relevant parameters can be selected easily. The parameter telegram is then created in the background.

Select the "Parameter Assignment" tab, see Figure 2-19 on page 2-27. A module-specific dialog box is opened:

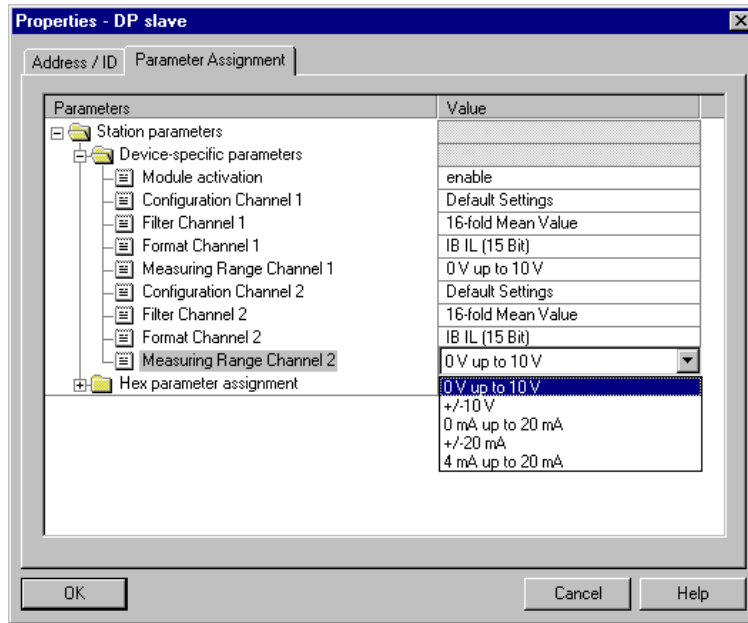

Figure 2-22 Selection using a dialog box for the IB IL AI 2/SF

IL PB BK DP/V1

In some tools it is possible to directly specify the hexadecimal encoding of the parameters. In this case, you can work with the detailed description of the parameter telegram (see "Format of the parameter telegram" on page A-6) and with the GSD file.

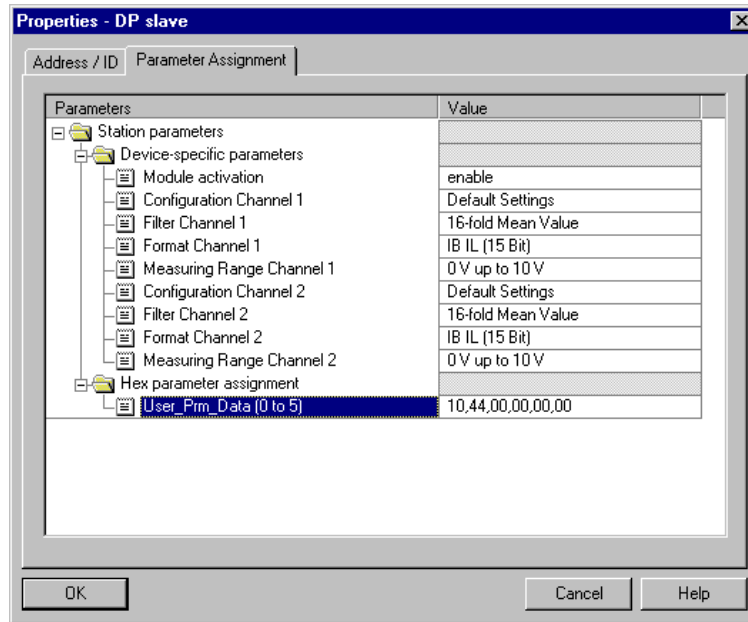

Figure 2-23 Selection in hexadecimal format for the IB IL AI 2/SF

The bus coupler also offers the option of setting various parameters.

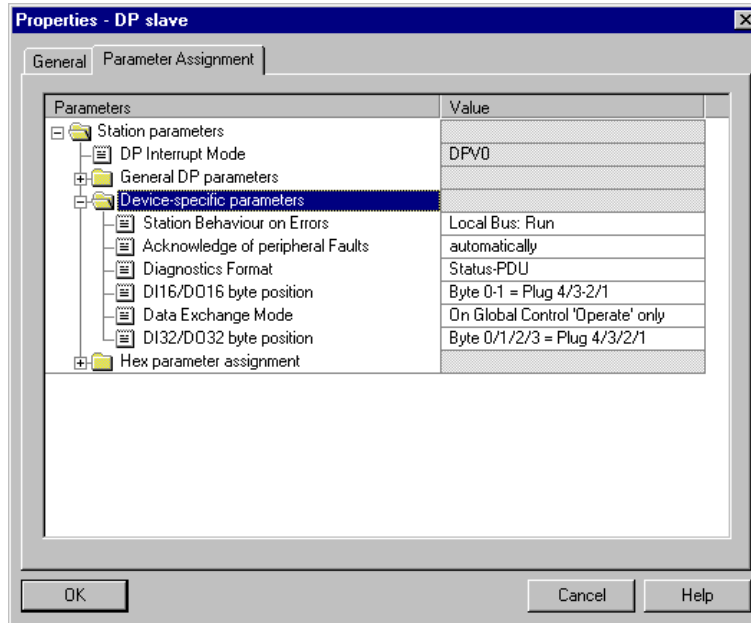

Figure 2-24 Parameters on the bus coupler

2.7.5 Failsafe values

2.7.5.1 General information about failsafe values

Failsafe values

Failsafe values are output values, which are used as output data in the event of a communication error (activation of response monitoring) or a PLC stop. Different values may be appropriate, depending on the application. It is therefore possible to select:

1. Hold last value
2. Output 0
3. Switch replacement value

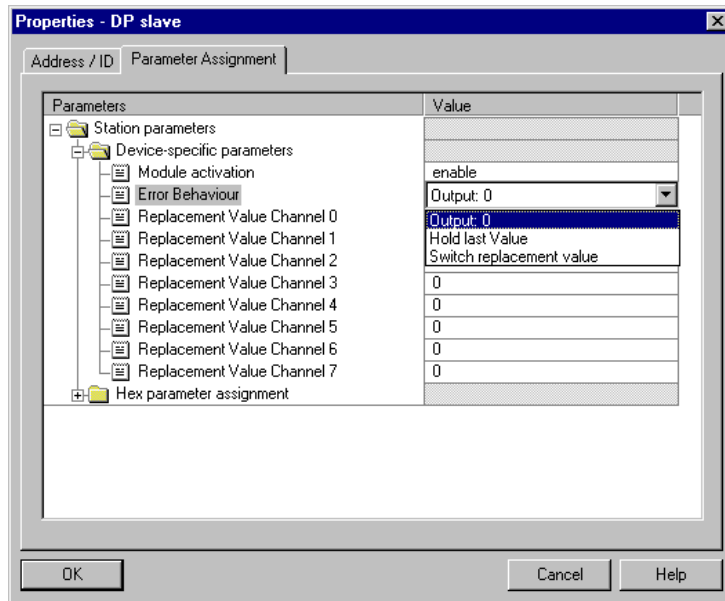

Figure 2-25 Setting the output behavior of a terminal

If option (3) "Switch replacement value" (apply specified value) is selected, then the substitute value, which can be freely selected from within the data area, is used. For a digital output, 0 or 1 can be selected. For an analog terminal, a value between -32768 and 32767 (bipolar) or 0 and 32512 (unipolar) can be selected. Depending on the terminal and the set data area, this value is converted into a current or voltage value.

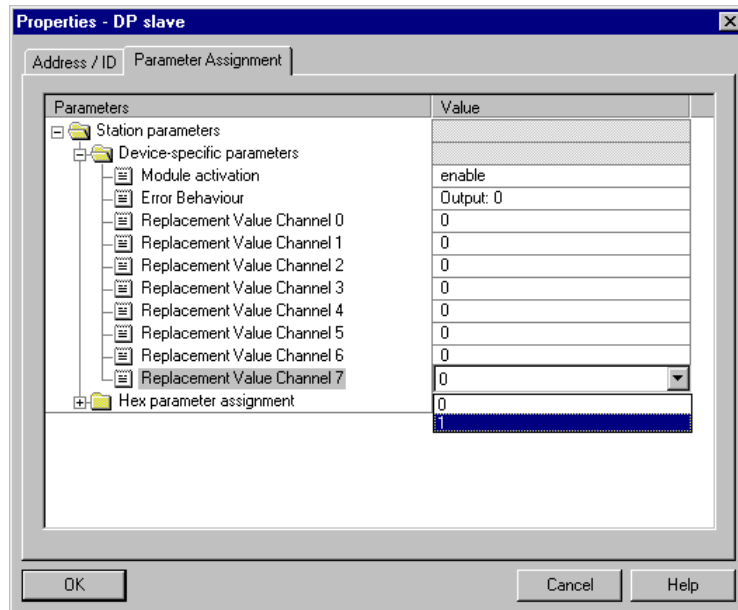

Figure 2-26 Selecting substitute values, 8-channel digital output terminal

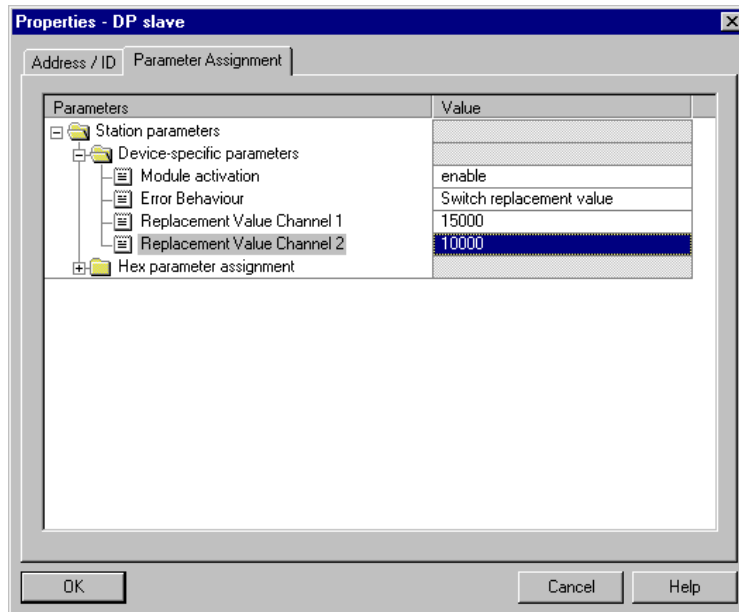

Figure 2-27 Selecting substitute values, 2-channel analog output terminal



The module format in the GSD file is described in the AH D IL PB BK module formats application note (see Section 6.2.3, "Ordering data for documentation") and is not limited by adding failsafe and parameter values. In other words, parameter data is added to the previous configuration data. These data types are independent of one another.

2.7.5.2 Activation of failsafe values

Failsafe values become valid if:

1. There is no communication with the PLC (response monitoring)
2. The control system is stopped
3. There is no process data traffic after power up, even though the parameter telegram has already been received

In scenario (1), there is no connection to the PLC. An example of this is a broken cable. If the response monitoring time has elapsed and no telegrams have been received, the substitute value is output if response monitoring is active.

In scenario (2), the control system managing the process data has stopped. No process data is exchanged. As soon as the control system indicates that it has stopped, the substitute value is used. The various control systems indicate their status at intervals using a broadcast.

Finally, it is also possible that the PLC is running but the device has not been activated yet (3). In this case, the station receives parameter and configuration telegrams. However, it cannot be guaranteed that the status of the control system (RUN/STOP) is known or that directly valid data telegrams are being sent. Therefore the safety values, which were already transmitted in the parameter telegram, are output.



If data exchange is enabled without global command "Operate", the CPU stop, which is sent via a broadcast in the same way as "Operate", is ignored, see also Section 2.7.10 on page 2-48. The last data output by the CPU is used. In this case, the failsafe values are only activated, if response monitoring has been enabled on the slave.



The BF LED flashes when the failsafe values are transmitted. This indicates locally that the output data is being controlled by the local slave.

2.7.5.3 Behavior on PLC stop in DP/V1 mode

PLC stop in DP/V1 mode

On a PLC stop in the new mode (DIP switch 8 = ON), cycles are still run in the local bus. The parameterized failsafe values are output on the output terminals. If a terminal has not been parameterized, the value 0 (for digital outputs) or "Hold" (for analog outputs) is used. The BF LED flashes when the failsafe values are transmitted. This indicates locally that the output data is being determined by the failsafe values.

Since the local bus continues to operate, DP/V1 commands can still be transmitted and processed via the C2 master. This increases the station availability.

2.7.6 Diagnostics

For detailed error codes, please refer to "Error description" on page A-1.

Selecting the diagnostic format

The diagnostic format can be set as a parameter on the bus coupler. You can select either "Status-PDU" (display as status PDU) or "Identifier related" (ID-specific diagnostics).

It is also possible to select the diagnostics for the previous version of the IL PB BK, which means that you can reuse operations, which were applied to the previous diagnostics.

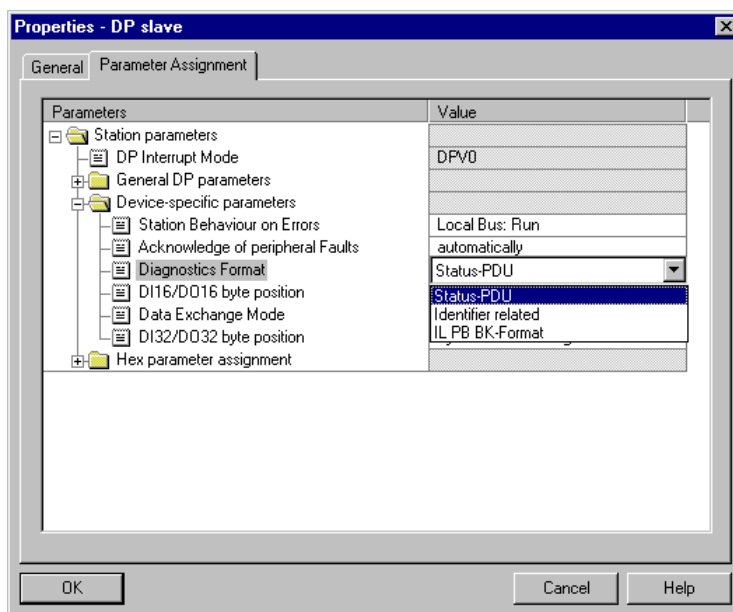

Figure 2-28 Selecting the diagnostic format



For reasons of compatibility, in IL PB BK mode (DIP 8 = OFF) only the usual diagnostic format of the IL PB BK is supported.

For a description of the diagnostics for byte 0 to byte 5, which applies to all PROFIBUS devices, please refer to "PROFIBUS standard diagnostics" on page 5-6.

Additional information for station diagnostics starts at byte 6.

Status PDU block

Table 2-8 Status PDU block

Byte No.	Value	Description
Bytes 0 to 5		PROFIBUS standard diagnostics
Byte 6	09 _{hex}	DP/V1 status PDU header
Byte 7	81 _{hex}	DP/V1 status PDU type - Status PDU
Byte 8	Device No.	DP/V1 status PDU slot
Byte 9	0 to 2	DP/V1 status PDU specifier
Byte 10	0 to 6	DP/V1 status PDU user: Error type*
Byte 11	0 to 12	DP/V1 status PDU user: Error number*
Byte 12	0 to 255	DP/V1 status PDU user: ID code (local bus)
Byte 13	0 to 255	DP/V1 status PDU user: Length code (local bus)
Byte 14	41 _{hex}	DP/V1 status PDU USER: Software version

* See "Error description" on page A-1

Specifier

- 0: No change
- 1: Error present
- 2: Error no longer present

Error type

- 0: No error
- 1: PROFIBUS parameter error (Set_Prm)
- 2: PROFIBUS configuration error (Chk_Cfg)
- 3: INTERBUS configuration error
- 4: INTERBUS error within the station
- 5: Terminal error
- 6: Parameter error on the local bus

Error number

0 to 12: Depends on the error type (see "Error description" on page A-1).

From configuration through to startup

A peripheral fault on terminal 2 (IB IL 24 DO 8) is displayed in status PDU format as follows:

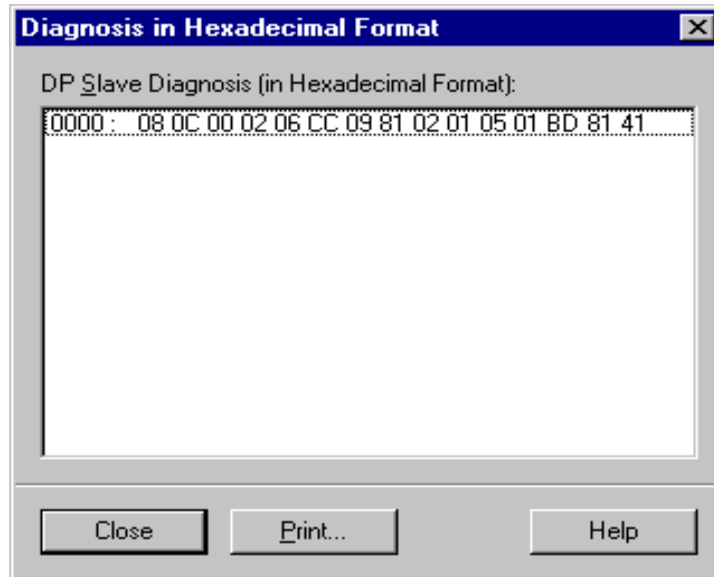

Figure 2-29 Peripheral fault on terminal 2 in status PDU format

ID-specific (terminal) diagnostics

Table 2-9 ID-specific (terminal) diagnostics

Byte No.	Value	Description
Bytes 0 to 5		PROFIBUS standard diagnostics
Byte 6	49 _{hex}	Header
Byte 7	0 to 255	Terminals 1 to 8
Byte 8	0 to 255	Terminals 9 to 16
Byte 9	0 to 255	Terminals 17 to 24
Byte 10	0 to 255	Terminals 25 to 32
Byte 11	0 to 255	Terminals 33 to 40
Byte 12	0 to 255	Terminals 41 to 48
Byte 13	0 to 255	Terminals 49 to 56
Byte 14	0 to 255	Terminals 57 to 64

Bytes 2 to 9:

A bit is reserved for each terminal.

If the bit is set, there is an error at the terminal.

Byte 0 bit 0: Terminal 1

Byte 0 bit 1: Terminal 2

- : -

Byte 0 bit 7: Terminal 8

Byte 1 bit 0: Terminal 9

Etc.

The error message in "ID-specific diagnostic format" is:

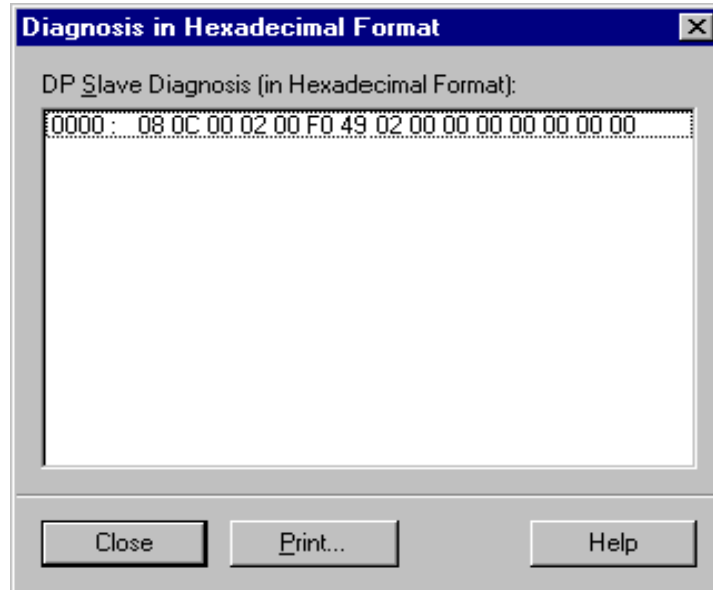

Figure 2-30 Peripheral fault on terminal 2 in "ID-specific diagnostic format"

IL PB BK DP/V1

Device-specific diagnostics

Table 2-10 Device-specific diagnostics (IL PB BK format)

Byte	Meaning	Explanation
0 to 5		PROFIBUS standard diagnostics
6	0A _{hex} header byte	Number of device-specific diagnostic bytes
7	00 _{hex} diagnostics type	Diagnostics version
8	Firmware version	This contains the firmware version in ASCII code. Example: 45 _{hex} corresponds to version "E".
9	Error type (for meaning see "Error description" on page A-1)	The error type is explained in the error table, see "Error description" on page A-1.
10	Error number (for meaning see "Error description" on page A-1)	The error number is explained in the error table, see "Error description" on page A-1.
11	Device number of the Inline terminal or the FLM module at the error location	This byte contains the logical number of the Inline terminal or the FLM module in which a peripheral fault has occurred (e.g., a short circuit at an output). In the event of data transmission errors, it indicates, together with byte 12, a faulty path between two terminals/modules. Passive devices such as power terminals without diagnostics or FLM branch modules are not counted.
12	Device number of the Inline terminal or the FLM module at the error location	This byte contains the logical number of the Inline terminal or the FLM module in which a peripheral fault has occurred (e.g., a short circuit at an output). In the event of data transmission errors, it indicates, together with byte 11, a faulty path between two terminals/modules. Passive devices such as power terminals without diagnostics or FLM branch terminals are not counted.
13	Inline ID code	The ID code of the Inline terminals is used for identification and is marked on the housing and printed in the terminal data sheet.
14	Inline length code	The length code is used for identification and to automatically set the data width. This is also printed in the terminal data sheet.
15	Reserve	

Using the usual IL PB BK diagnostics, the error is indicated as follows:

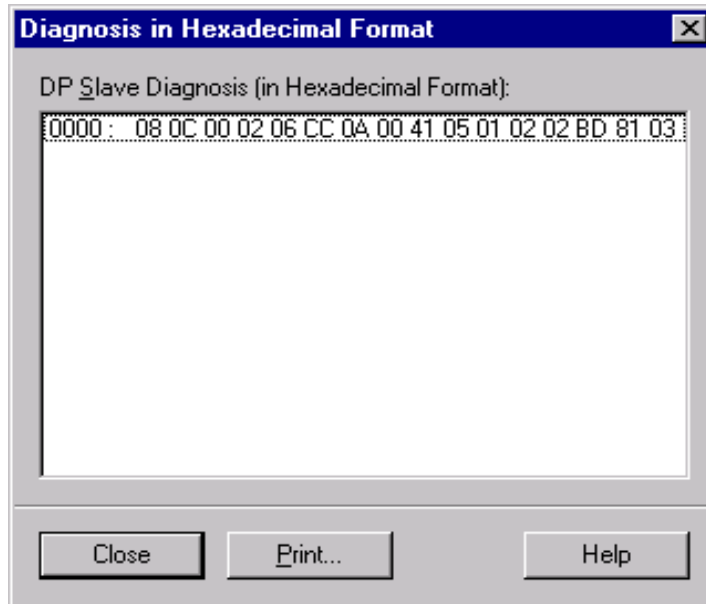

Figure 2-31 Peripheral fault on terminal 2 in usual manufacturer-specific IL PB BK format

2.7.7 Acknowledging peripheral faults

Peripheral faults are errors that are triggered by some I/O terminals in the event of specific error states. Some errors have to be acknowledged, while others do not.

Errors that do not have to be acknowledged

Errors that do not have to be acknowledged include, for example, an output short circuit on an IB IL 24 DO 16. These errors are reset automatically when the error cause is removed.

Errors that have to be acknowledged

An error that has to be acknowledged is generated, for example, when the electronic fuse on an IB IL 24 SEG-ELF is tripped. The error must be acknowledged either automatically or manually on the bus coupler. This setting is made during parameterization of the bus coupler:

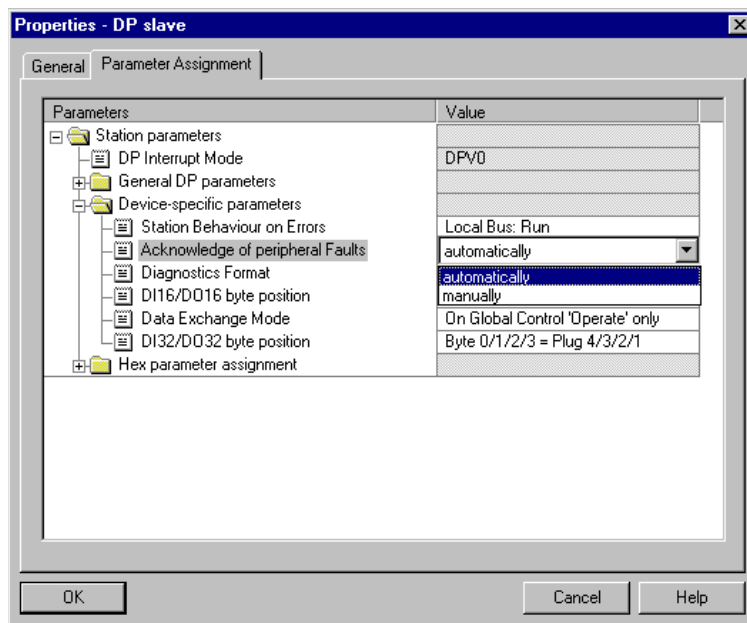

Figure 2-32 Setting for acknowledging peripheral faults

From configuration through to startup

Manual acknowledgment

An error can be acknowledged manually via DP/V1 (C1 and C2 master) or standard DP. The system writes to the bus coupler (slot 0), index 0004, subindex 00 (= 02_{hex}). Bit 1 (= 02_{hex}) should be set for the acknowledgment. The data length is exactly 1 byte (see "Acyclic communication (DP/V1 and PCP)" on page 3-1).

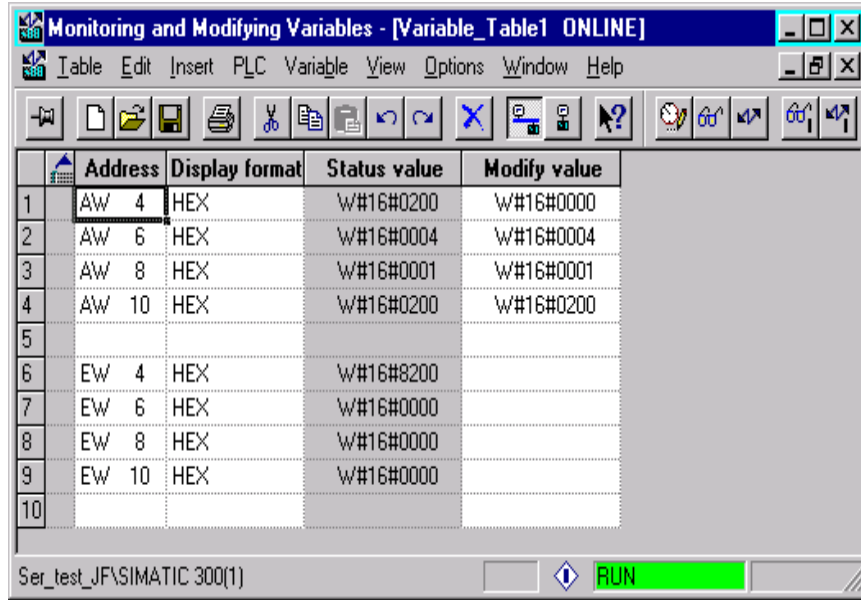

Figure 2-33 Manual acknowledgment of peripheral faults in standard DP

The following telegram should be sent via DP/V1 (for C1 and C2 masters) for an acknowledgment:

Table 2-11 Telegram for the acknowledgment of peripheral faults

Master	Data contents	Remark
C1 master	5F 00 04 01 02	
C2 master	5F 00 04 01 02	Do not forget "Initiate"

2.7.8 Byte rotation for IB IL 24 DI 16/IB IL 24 DO 1 terminals

In order to adapt 16-channel digital terminals to the data format of the control system, the byte position of channels 1 - 8 and 9 - 16 can be rotated.

By default, channels 9 - 16 (slot 3.x and 4.x) are on byte n and channels 1 - 8 (slot 1.x and 2.x) are on byte n+1.

If bit 4 is set in the control byte (parameter telegram, byte 11, see "Format of the parameter telegram" on page A-6), then the format is rotated. Channels 1 - 8 (slot 1.x and 2.x) are then on byte n and channels 9 - 16 (slot 3.x and 4.x) are on byte n+1.

Table 2-12 Default (bit 4 = 0)

Byte	Byte 0								Byte 1							
Bit	7	6	5	4	3	2	1	0	7	6	5	4	3	2	1	0
Slot	4				3				2				1			
Terminal point	2.4	1.4	2.1	1.1	2.4	1.4	2.1	1.1	2.4	1.4	2.1	1.1	2.4	1.4	2.1	1.1

Table 2-13 Rotated (bit 4 = 1)

Byte	Byte 1								Byte 0							
Bit	7	6	5	4	3	2	1	0	7	6	5	4	3	2	1	0
Slot	4				3				2				1			
Terminal point	2.4	1.4	2.1	1.1	2.4	1.4	2.1	1.1	2.4	1.4	2.1	1.1	2.4	1.4	2.1	1.1

2.7.9 Byte rotation for IB IL 24 DI 32/IB IL 24 DO 32 terminals

In order to adapt 32-channel digital terminals to the data format of the control system, the byte position of channel groups 1 - 8, 9 - 16, 17 - 24, and 25 - 32 can be rotated.

By default, channels 1 - 8 (slot.x) are on byte n+3 and channels 9 - 16 (slot 2.x) are on byte n+2, channels 17 - 24 (slot 3.x) are on byte n+1, and channels 25 - 32 (slot 4.x) are on byte n.

If bit 6 is set in the control byte (parameter telegram, byte 11, see "Format of the parameter telegram" on page A-6), then the format is rotated. Channels 1 - 8 (slot 1.x) are then on byte n and channels 9 - 16 (slot 2.x) are on byte n+1, channels 17 - 24 (slot 3.x) are on byte n+2, and channels 25 - 32 (slot 4.x) are on byte n+3.

Table 2-14 Default (bit 6 = 0)

Byte	0					1					2					3				
Bit	7	6	...	1	0	7	6	...	1	0	7	6	...	1	0	7	6	...	1	0
Slot	4					3					2					1				
Terminal point	8.4	7.4	...	8.1	7.1	6.4	5.4	...	6.1	5.1	4.4	3.4	...	4.1	3.1	2.4	1.4	...	2.1	1.1

Table 2-15 Default (bit 6 = 1)

Byte	0					1					2					3				
Bit	7	6	...	1	0	7	6	...	1	0	7	6	...	1	0	7	6	...	1	0
Slot	1					2					3					4				
Terminal point	2.4	1.4	...	2.1	1.1	4.4	3.4	...	4.1	3.1	6.4	5.4	...	6.1	5.1	8.4	7.4	...	8.1	7.1

2.7.10 Data exchange and global command "Operate"

Broadcast messages

PROFIBUS supports broadcast messages, which the PLC can use to indicate its status. For example, the CPU313C-2 DP is a CPU, which indicates its status to other devices in the network using these broadcast messages. The IL PB BK DP/V1-PAC bus coupler uses this message to determine whether process data values or failsafe values should be output.

Usually, when the bus coupler receives a parameter telegram it first starts with the failsafe values until it receives the broadcast message and then either maintains the failsafe values or switches to process data mode, depending on the PLC status.

Data exchange without broadcast "Operate"

However, it is also possible that PLCs do not indicate their status. In this case, the option of "data exchange without broadcast "Operate"" can be used. In the parameter telegram it is possible to specify that the device should not wait for the control system broadcast. I.e., the process data is exchanged immediately after parameterization and configuration when the first data telegram is received.

In the event of a control system stop, this is indicated by the CPU313C-2 DP and the system switches immediately to the failsafe values. If the PLC does not indicate this or the option is not active, the failsafe values are only triggered once the response monitoring time has elapsed. Until then the last process data remains valid.

The evaluation of the broadcast can be set in bit 5 of the control byte for the bus coupler (see "Format of the parameter telegram" on page A-6).

2.8 Response monitoring

Response monitoring

The response monitoring function, also referred to as the watchdog, checks that telegrams are received within a specified maximum time period. If no valid telegram is received in this period, the monitoring mechanism is triggered and failsafe settings are activated on the slave. These settings affect output terminals in particular, and a failsafe value is output as a substitute value.

This also means that there is no longer any communication with the master (e.g., cable interrupt). If communication between the master and slave is restored, a normal slave startup must be completed, i.e., with parameterization and configuration telegrams. This ensures that the local configuration matches the configuration stored on the PLC.

Options are available for activating/deactivating response monitoring and for parameterizing the time when response monitoring is activated. Values from 0 (no monitoring) to 650 s can be set in increments of at least 10 ms. Many configuration tools make these settings automatically to save work for the user. Finally, the cycle time should also be taken into account when setting the monitoring time. This depends on the entire network.

In STEP 7, response monitoring is activated or deactivated in the hardware configurator under "Properties - DP slave":

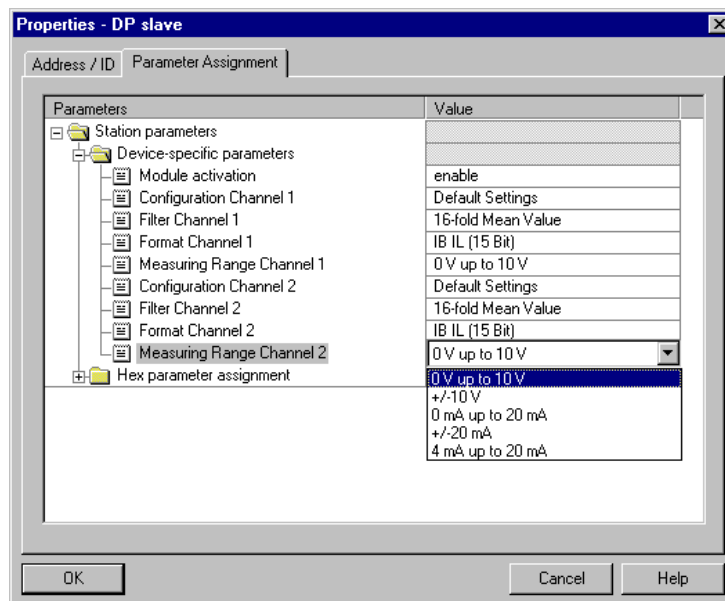

Figure 2-34 Activating response monitoring

The duration of response monitoring can be set in the network settings:

"Properties - DP master system" -> "Properties" -> "Network settings" -> "Bus parameters"

IL PB BK DP/V1

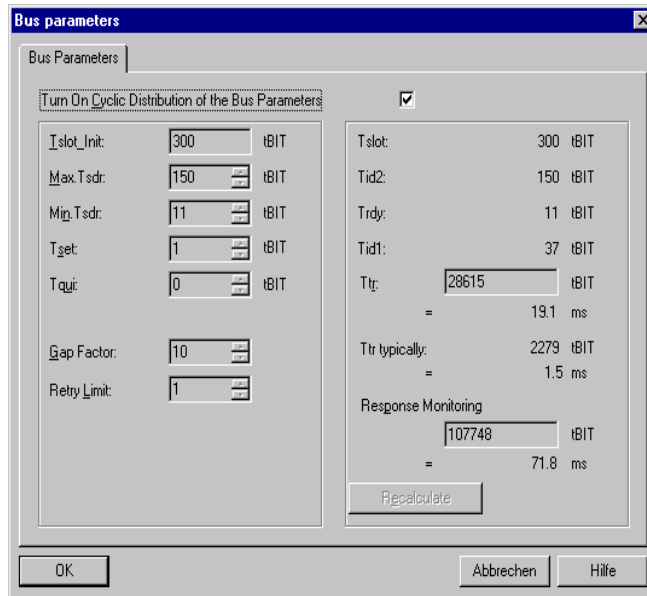

Figure 2-35 Setting response monitoring

In this case, the response monitoring time for all devices in the network is set to the same time. However, this setting is transmitted individually in the parameter telegram for each device, which means that the response monitoring time can be set individually with other configuration tools.

3 Acyclic communication (DP/V1 and PCP)

DP/V1

DP/V1 extends the cyclic data exchange function according to IEC 61158 to include acyclic services. This makes it easy to operate even complex devices.

PCP

PCP is used in the local bus to exchange data acyclically. Usually this is parameterization data from complex modules (e.g., IB IL DC AR) or variable length data from modules, which can be connected to devices such as the IB IL RS 232-PAC or the IB IL RS 485-PAC.

DP/V1 is a mechanism which corresponds to PCP at PROFIBUS level. The PROFIBUS coupler prepares the data records, which are sent via DP/V1 from the Class 1 or Class 2 master, for the PCP mechanism in the local bus. PCP data from the local bus is in turn converted into DP/V1 telegrams by the IL PB BK DP/V1-PAC.



Before programming the application, check whether your control system or configuration tool supports DP/V1. If not, the functions can be used via the cyclic process data channel (DP/V0), see "PCP communication via process data (C1 master in DP/V0 mode)" on page 3-20.

The following distinctions must be observed regarding communication:

3.1 Acyclic communication via the Class 1 master (C1 master)

C1 master

The C1 master carries out parameterization during slave startup and is also the master for cyclic data traffic. It may also be necessary to operate a V.24 (RS-232) interface acyclically from this C1 master or to read a parameter from the device as an option.

Corresponding read and write access rights are therefore defined for the C1 master. As it already has a connection to the slave during cyclic data traffic, the C1 master does not have to establish an explicit connection (using "Initiate"), but can communicate with the slave directly via "Read" and "Write".

3.2 Acyclic communication via the Class 2 master (C2 master)

C2 master

For communication in the C2 master, the data fields are identical to those for C1 communication, and it is only the SAPs (Service Access Points) which differ. The additional effort required is the use of "Initiate" and "Abort" to establish and release the connection via SAP49 and 50. If DP/V1 devices are already in use, the routines for connection management can be adapted easily.

The C2 master can be implemented in various forms, e.g., in the form of a display device or operator interface. In a display device, the data is retrieved from the slave on request if, for example, a specific parameter is to be read. Access to the operator interface is usually acyclic.



Only one active DP/V1 communication is permitted at any time. A total of up to eight PCP-compatible terminals can be connected to the PROFIBUS DP/V1 bus coupler.

3.3 PCP communication basics

PCP (Peripherals Communication Protocol) controls the transmission of parameter data in the local bus. Special PCP services are available for this purpose.

Application example

To explain the basics of PCP communication, the following concrete PCP application is used as an example:

A frequency inverter (FI), together with other field devices, is connected to a PLC via a bus interface. The device versions are standardized according to the Drives profile.

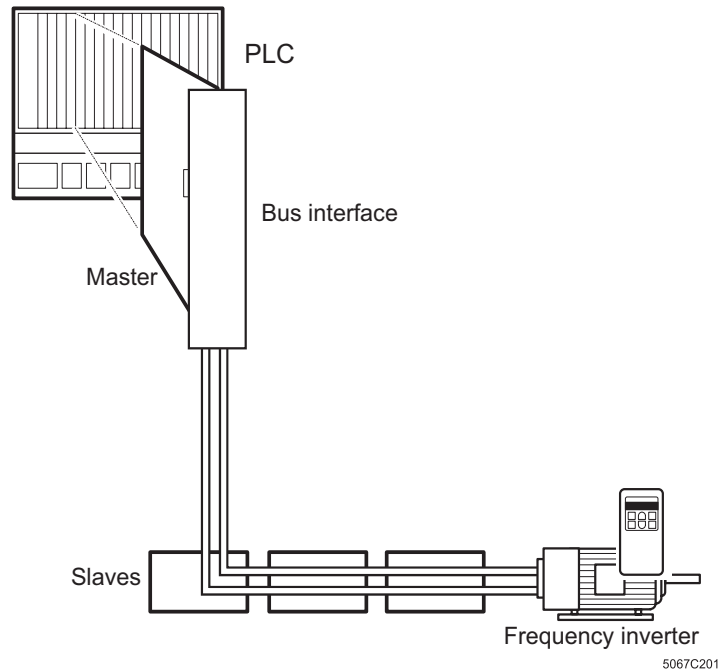

Figure 3-1 Application example

Device parameters

Device parameters are data from intelligent field devices (PCP devices), which is required for the startup phase of machines and systems. Once it has been entered, this data only has to be modified in the event of a change to the parameterization or in the event of an error. The parameters are preconfigured and can be taken from the device documentation provided by the manufacturer.

Parameters of a frequency inverter

As an electrical drive controller, a key feature of a frequency inverter is that changes can be made to process variables (e.g., speed, position, and torque) using analog or digital signals. Additional information is required for optimum adaptation of the drive controller and motor to the process. As well as setpoint information, the frequency inverter also requires information about the motor rating, the minimum and maximum permissible speed of the system, the maximum speed variation during acceleration and deceleration, starting ramp, starting current, etc.

IL PB BK DP/V1

These types of additional information are device-specific parameters, which can be modified via the parameter data channel.

The parameter values for all PCP devices are the subject of communication via the parameter data channel. In order to distinguish between the individual parameters during communication, each parameter has a unique number, the index.

Object dictionary (OD)

The index is listed together with the description of the parameter properties in a standardized list, the object dictionary (OD). Each PCP device, which exchanges information via the parameter data channel, has its own object dictionary.

Index

The index is the address of the communication object. It is required to identify the object.

Table 3-1 Object description (example)

Object description (OD)			
Index	Type	Object	Name
...
60 4A _{hex}	Ramp	Record	Speed quick stop
60 4B _{hex}	Integer16	Array	Setpoint factor
...

Object description

The object description includes all the properties of the object, such as data type, object type, name, etc.

Object types

There are various different object types:

Simple variable

- Simple variable type objects.
Examples include measured values, the time or status of a device.

Array

- Array type objects, i.e., several "simple variable" objects of the same type, which are grouped to form one object. Each element can be accessed individually.
An example of an array is a range of the same type of measured values.

Record

- Record type objects, i.e., several "simple variable" objects of different types, which are grouped to form one object. As for the array type, each element of a record can be accessed individually. An example of a record is the group of data in a test report, which contains not only the actual measured value, but also additional information, e.g., the time of the measurement.

Program invocation

- Program invocation type objects, i.e., program sequences that can be run.



For additional information about PCP communication, please refer to the IBS SYS PCP G4 UM E user manual.

3.4 Acyclic communication in DP/V1 mode

3.4.1 The communication mechanism

Whenever data is accessed, a distinction must be made between accessing data from terminals in the local bus and data from the bus coupler:

Table 3-2 Assignment of data

Data type	Access to local bus terminal	Access to bus coupler	Slot	Index/dec
Terminal parameters	x			2
Control byte (byte 4 of the bus coupler)		x	0	3
Local bus stop acknowledgment		x	0	4
Peripheral fault acknowledgment		x	0	4
Overview of PCP terminals and status		x	0	5
Deactivation of terminals		x	0	6
Activation status of terminals		x	0	7
Station ID		x	0	8
Terminal parameters (power up)	x		1 to 63	9
Specify active configuration as power up configuration		x	0	10
Delete saved configuration		x	0	11
PCP data with invoke ID	x		1 to 63	47
PCP data	x		1 to 63	48

When accessing the bus coupler, use the usual DP/V1 format. Read and write access can be executed in 1(2) step(s).

The PCP data from I/O terminals is usually addressed via 16-bit object indices. DP/V1 only has fields for 8-bit indices. Additional parameters have therefore been added to the data block for use when accessing the local bus, as for PROFIDrive. A sequence involving 2 (4) steps is used, which follows the PROFIDrive profile:

IL PB BK DP/V1**Read:**

1. a) Send the request as a write (read) to slot x
b) Poll the response to write (read) - usually performed automatically by the master
2. a) Send a read to slot x
b) Poll the response to read - usually performed automatically by the master

Write:

1. a) Send the request as a write (write) to slot x
b) Poll the response to write (write) - usually performed automatically by the master
2. a) Send a read to slot x
b) Poll the response to read - usually performed automatically by the master

Note that when communicating with objects on local bus terminals, the response should be fetched using "Read". Otherwise on the next communication attempt, the DP/V1 error code DF 80 B5 00 will indicate that the terminal is busy. In this case, this means that the terminal is waiting because it has not yet had a response from the last communication.

Communication is carried out via DP/V1 index 47 and 48, and the object index and assigned subindex of the I/O terminal are transmitted as part of the data field.

Request and response

The section below provides additional information about the format of write and read access (request and response).

The format for all types of access (request and response, read and write) in DP/V1 is:

<DP/V1 header> <Data (PCP/DP/V1)>

The DP/V1 header always has the following format:

<DP/V1 service> <Slot> <DP/V1 index> <DP/V1 length>

The <Data (PCP/DP/V1)> is optional depending on the service and has the following structure:

Table 3-3 Structure of the data depending on the service

Access	Service	Data
Write objects (bus coupler)	Request	Object data
	Response	None
Read objects (bus coupler)	Request	None
	Response	Object data
Write objects (I/O terminals)	Write request (write)	Write PCP/Index high/Index low/Subindex/ Length of PCP data/x bytes of PCP object data
	Write response (write)	None
	Read request (write)	None
	Read response (write)	PCP acknowledgment
Read objects (I/O terminals)	Write request (read)	Read PCP/Index high/Index low/Subindex
	Write response (read)	None
	Read request (read)	None
	Read response (read)	PCP acknowledgment

Acyclic communication (DP/V1 and PCP)

Table 3-3 Structure of the data depending on the service

Access	Service	Data
Write objects with invoke ID	Write request (write)	Invoke ID/Write PCP/Reserved/Reserved/Reserved/Reserved/Index high/Index low/Reserved/Subindex/Reserved/Length of PCP data/x bytes of PCP object data
	Write response (write)	None
	Read request (write)	None
	Read response (write)	Invoke ID (mirrored)/Write PCP/Reserved/Reserved
Read objects with invoke ID	Write request (read)	Invoke ID/Read PCP/Reserved/Reserved/Reserved/Reserved/Index high/Index low/Reserved/Subindex
	Write response (read)	None
	Read request (read)	None
	Read response (read)	Invoke ID (mirrored)/Read PCP/Reserved/Reserved/Reserved/Length of PCP data/x bytes of PCP object data

In the event of a faulty response, the format is as follows:

- For a DP/V1 error:
<DP/V1 service> <Error decode> <Error code 1> <Error code 2>
- For an I/O module error:
<DP/V1 service> <Slot> <DP/V1 index> <DP/V1 length> <Error data (PCP/DP/V1)>

The meaning of the individual parameters is as follows:

- <DP/V1 service>:

In the request there is a distinction between DP/V1 read ($5E_{hex}$) and DP/V1 write ($5F_{hex}$); in the error response there is a distinction between DE_{hex} (read error) and DF_{hex} (write error).

- <Slot>:

The slot of the terminal to be addressed in the station. The bus coupler is addressed with slot = 0, the first I/O terminal with slot = 1, the second with slot = 2, etc. The slot provides a reference to a specific terminal, e.g., also for the terminal parameters.

- <DP/V1 index>:

The index to be used for accessing local bus communication objects is index 48_{dec} (30_{hex}). Indices 2 to 5 should be used for all other services. Index 47_{dec} is reserved for future use and should therefore not be assigned.

- <DP/V1 length>:

For write access, the length of the subsequent data is specified here, and for read access, the length of the expected data is specified. On a response, this parameter contains the actual length of the DP/V1 data.

-<Error data (PCP/DP/V1)>:

Error codes from PCP access to the local bus (see "Error codes for DP/V1 and VC1 communication" on page A-12).

- <Error decode>:

80_{hex} indicates an error in DP/V1.

IL PB BK DP/V1

- <Error code 1> and <Error code 2>:

Error codes from DP/V1 access (see "Error codes for DP/V1 and VC1 communication" on page A-12).

- <Write PCP/read PCP>:

This specifies whether the following object index should be written or read. Read PCP = 01_{hex} ; write PCP = 02_{hex} .

- <Object data>

This is only the contents of an object. The length and scope of the data has already been described by <DP/V1 length>.

- <Index high and Index low>

This specifies the object index of the addressed PCP object in two bytes. For example, for index $5FE0_{hex}$ the value $5F_{hex}$ should be entered for Index high and the value $E0_{hex}$ should be entered for Index low.

- <Subindex>

When working with a PCP object, the subindex can be used to select a specific element from an array or record.

- <Length of PCP data>

This value specifies how many bytes of PCP object data (object contents) follow.

- <PCP object data>

This is the actual contents of a PCP object.

- <PCP acknowledgment>

The structure of a PCP acknowledgment is as follows:

- <Message code> <Result> <Length of PCP data> <PCP object data>

- <Message code> <Result> <PCP error code>

- <Invoke ID> The invoke ID is one byte in length and is used for channel selection on some terminals.

The message code is 81_{hex} (PCP read) or 82_{hex} (PCP write). The result has the function of a status byte (0 means "OK", 44_{hex} means "general error"). "Length of PCP data" and "PCP object data" only contain specific values on a read response (read). "Length of PCP data" specifies how many bytes of PCP object data (object contents) follow. The "PCP object data" contains the actual contents of a PCP object. In the event of an error, the status byte is directly followed by the PCP error code, see "Error codes for DP/V1 and VC1 communication" on page A-12.



When accessing PCP, note that the first byte in the DP/V1 data block uses PCP read (01_{hex}) and PCP write (02_{hex}) to indicate whether the PCP object should be read or written.

3.4.2 Examples

The section below provides a few examples to aid understanding (all values in hex). These examples show how objects on the bus coupler and the I/O terminals can be read and written.

The station structure is as follows:

- IL PB BK DP/V1-PAC
- IB IL 24 DO 8-PAC
- IB IL 24 DI 8-PAC
- IB IL RS 232-PAC
- IB IL AI 2/SF-PAC
- IB IL AO 1/SF-PAC

In order to understand the examples, knowledge of the object dictionary is also required. The object dictionary of the IB IL RS 232-PAC has the following structure:

Table 3-4 Object dictionary of the IB IL RS 232

Index	Data type	N	L	Meaning	Object name	Rights
5FC1 _{hex}	Var of unsigned 8	1	1	Module start indicator	START-IND	rd/wr
5FE0 _{hex}	String var of octet string	1	58	Receive/transmit V.24 (RS-232) data	V24-DATA	rd/wr
5FFF _{hex}	Array of unsigned 8	20	1	Terminal configuration	INIT-TABLE	rd/wr

N: Number of elements

rd: Read access permitted

L: Length of an element in bytes

wr: Write access permitted

IL PB BK DP/V1

Due to pre-assignment with default values and the array structure, index 5FFF_{hex}, which contains details of the protocol, is a good example:

Writing the INIT-TABLE object with a write service configures the terminal.

Table 3-5 Object description

Object	INIT-TABLE	
Access	Read, write	
Data type	Array of unsigned 8	20 x 1 byte
Index	5FFF _{hex}	
Subindex	00 _{hex} Write all elements 01 _{hex} Protocol 02 _{hex} Baud rate 03 _{hex} Data width 04 _{hex} Reserved 05 _{hex} Reserved 06 _{hex} Error pattern 07 _{hex} First delimiter 08 _{hex} Second delimiter 09 _{hex} 3964R priority 0A _{hex} Output type 0B _{hex} DTR control system 0C _{hex} Rotation switch 0D _{hex} XON pattern 0E _{hex} XOFF pattern 0F _{hex} Reserved : : 14 _{hex} Reserved	
Length (bytes)	14 _{hex} subindex 00 _{hex} 01 _{hex} subindex 01 _{hex} to 14 _{hex}	
Data	IB IL RS 232-PAC terminal configuration	

Acyclic communication (DP/V1 and PCP)

A default value has already been assigned to the individual elements:

Table 3-6 INIT-TABLE object elements

Element		Meaning	Default setting		Data type
dec	hex		Code	Meaning	
1	1	Protocol	00 _{hex}	Transparent	Unsigned 8
2	2	Baud rate	07 _{hex}	9600 baud	Unsigned 8
3	3	Data width	02 _{hex}	8 data bits, even parity, 1 stop bit	Unsigned 8
4	4	Reserved	00 _{hex}		Unsigned 8
5	5	Reserved	00 _{hex}		Unsigned 8
6	6	Error pattern	24 _{hex}	(\$)	Unsigned 8
7	7	First delimiter	0D _{hex}	Carriage return (CR)	Unsigned 8
8	8	Second delimiter	0A _{hex}	Line feed (LF)	Unsigned 8
9	9	3964R priority	00 _{hex}	Low	Unsigned 8
10	A	Output type	00 _{hex}	V.24 (RS-232)	Unsigned 8
11	B	DTR control system	00 _{hex}	Automatic	Unsigned 8
12	C	Rotation switch	00 _{hex}	No rotation	Unsigned 8
13	D	XON pattern	11 _{hex}		Unsigned 8
14	E	XOFF pattern	13 _{hex}		Unsigned 8
15 - 20	F - 14	Reserved	00 _{hex}		Unsigned 8

The PROFIBUS DP/V1 bus coupler also has objects (see "Object dictionary for the PROFIBUS DP/V1 bus coupler" on page A-8).

Table 3-7 Assignment of object indices to an IL PB BK DP/V1 station

Slot	Index	Service	Remark
0	3	Write	Control byte (diagnostic format, manual peripheral fault acknowledgment, etc.)
0	4	Write	Acknowledgment of local bus event 1: Local bus stop acknowledgment 2: Peripheral fault acknowledgment
0	5	Read	Overview of PCP modules and status
1 to 63	2	Write	Terminal parameters
1 to 63	48	Read/write	PCP data

These objects (INIT-TABLE of the IB IL RS 232-PAC and bus coupler objects) can be used to indicate how an intelligent slave can be accessed via different masters.

IL PB BK DP/V1

**Example 1:
Reading the connected local PCP devices and their status
(slot 0, index 5 on the bus coupler)**

Read request (master -> slave)

Data	Data structure
5E 00 05 20	Read/Slot/Index/Maximum length

Read request (slave -> master)

Data	Data structure
5E 00 05 03 03 01 00	Read/Slot/Index/Actual length/3 bytes of object data

The data shows that there is a PCP device at slot 3, and its connection status is OK, see "Object dictionary for the PROFIBUS DP/V1 bus coupler" on page A-8. Byte 3 of the object data is reserved.

Acyclic communication (DP/V1 and PCP)

**Example 2:
Reading object 5FFF; subindex 2 of an IB IL RS 232 at slot 3,
access to I/O terminal**

Write request (master -> slave)

Data	Data structure
5F 03 30 04 01 5f ff 02	Write/Slot/Index/Length/Read PCP/Index high/Index low/Subindex

Write response (slave -> master)

Data	Data structure
5F 03 30 04	Write/Slot/Index/Length

Read request (master -> slave)

Data	Data structure
5E 03 30 28	Read/Slot/Index/Maximum length

Read response (slave -> master)

Data	Data structure
5E 03 30 04 81 00 01 07	Read/Slot/Index/Actual length/4 bytes of object data

This example illustrates how the typical PROFIDrive profile write and read sequence provides the requested value when a value is read. In this case, the write response does not contain any data. It only indicates that a write request has been received at the IL PB BK DP/V1-PAC. The data is only delivered by the read action.

81_{hex} means that PCP read has been executed. The status is 00_{hex}, which indicates that there were no errors. 01_{hex} indicates the length of the subsequent data and 07_{hex} is the value stored under 5FFF, subindex 2, see "A default value has already been assigned to the individual elements:" on page 3-11.

IL PB BK DP/V1

**Example 3:
Manual acknowledgment of peripheral faults
(writing to the bus coupler, slot 0, index 4)**

Write request (master -> slave)

Data	Data structure
5F 00 04 01 02	Write/Slot/Index/Length/1 byte of data

Write response (slave -> master)

Data	Data structure
5F 00 04 01	Write/Slot/Index/Length

In this case, the data block is only important in the request. The response indicates that the command has been received. As can be seen in "Object dictionary for the PROFIBUS DP/V1 bus coupler" on page A-8, peripheral faults should be acknowledged with bit 1 (02_{hex}) at index 4, slot 0.

Acyclic communication (DP/V1 and PCP)
**Example 4:
Writing to object 5FFF; subindex 0 of an IB IL RS 232 at slot 3**

Write request (master -> slave)

Data	Data structure
5F 03 30 19 02 5F FF 00 14 00 06 02 00 00 24 0D 0A 00 00 00 00 11 13 00 00 00 00 00 00	Write/Slot/Index/Total length of data/Write PCP/Index high/ Index low/Subindex/Length of PCP data/20 bytes of object data

Write response (slave -> master)

Data	Data structure
5F 03 30 19	Write/Slot/Index/Length

Read request (master -> slave)

Data	Data structure
5E 03 30 28	Read/Slot/Index/Maximum length

Read response (slave -> master)

Data	Data structure
5E 03 30 02 82 00	Read/Slot/Index/Actual length/2 bytes of data (PCP acknowledgment)

This example shows how subindex 00_{hex} can be used to write to all the subindices of a PCP object on an I/O terminal in a single step. In the write request data block, 14_{hex} indicates the length of the subsequent data. This is followed by the data, which is transmitted in this order according to the structure of the object.

The read response is simple. The data block receives 82_{hex} to confirm that the PCP data has been written. 00_{hex} again indicates the OK status.



A maximum of 58 bytes of PCP data may be transmitted per command.

IL PB BK DP/V1**Example 5:**

**In the event of an error: Reading a non-existent object on an I/O terminal with PCP functions
(access to 5C00, subindex 0 on an IB IL RS 232, slot 3)**

Write request (master -> slave)

Data	Data structure
5F 03 30 04 01 5C 00 00	Write/Slot/Index/Length/Read PCP/Index high/Index low/Subindex

Write response (slave -> master)

Data	Data structure
5F 03 30 04	Write/Slot/Index/Length

Read request (master -> slave)

Data	Data structure
5E 03 30 28	Read/Slot/Index/Maximum length

Read response (slave -> master)

Data	Data structure
5E 03 30 06 81 44 06 07 00 00	Read/Slot/Index/Actual length/6 bytes of object data

The write request here has a similar structure to example 2, see page 3-13. However, instead of index 5FFF and subindex 2, index 5C00 and subindex 00 are requested in this case.

This shows that the write response (as is usual for PROFIDrive and also in example 2) is simply being used to indicate that the command has been received. Processing on the local bus only starts afterwards. 81_{hex} indicates the execution of the command, and 44_{hex} already indicates a basic error.

On closer examination, it is clear that PCP read cannot be processed because the object does not exist, please refer to the IBS SYS PCP G4 UM E user manual or "Error codes for DP/V1 and VC1 communication" on page A-12. This is indicated by the error code 06_{hex} and 07_{hex} within the object data of the read response. The 2 bytes at the end provide additional information about the error, but are not used in this case. As the command was executed without errors on DP/V1, the error is indicated as an error in the lower-level local bus rather than a DP/V1 error. In these cases, refer to the I/O terminal data sheet and the general error description for PCP. 44_{hex} as the response status always indicates an I/O terminal error.

Acyclic communication (DP/V1 and PCP)

Example 6:

In the event of an error: Reading an object on an I/O terminal without PCP functions (access to 5FF0, subindex 0 on an IB IL DO 8, slot 2)

Write request (master -> slave)

Data	Data structure
5F 02 30 04 01 5f ff 00	Write/Slot/Index/Length/Read PCP/Index high/Index low/Subindex

Write response (slave -> master)

Data	Data structure
DF 80 D2 00	Write error/Error decode/Error code 1/Error code 2

Read request (master -> slave)

Data	Data structure
5E 02 30 28	Read/Slot/Index/Maximum length

Read response (slave -> master)

Data	Data structure
DE 80 D4 00	Read error/Error decode/Error code 1/Error code 2

In this case, DF_{hex} in the write response already indicates that the service cannot be executed. The service cannot be sent to the I/O terminal, so the error code is indicated immediately. For these types of error, the DP/V1 error codes are helpful, see "Error codes for DP/V1 and VC1 communication" on page A-12.

In this example, 80_{hex} means that the error is a DP/V1 error. D2 00 indicates that the terminal does not have PCP. In this instance, the process should be aborted immediately after the write action. However, if the system tries to read the result at slot 2, D4 00 is output ("Incorrect service", see "Error codes for DP/V1 and VC1 communication" on page A-12). This indicates that this command is not expected at present. There is no read data available at the slot.

If you use I/O terminals, which do not establish the PCP connection immediately following power up, error code D1_{hex} may be displayed when PCP communication is attempted for the first time. This code indicates that there is (still) no PCP connection. At the same time, an attempt is made to establish this connection with the terminal so that the problem will not re-occur the next time a communication attempt is made.

In the event of doubt, index 5 can be used to request the PCP communication status and even establish communication if all PCP devices do not yet have a connection. To do this, write 01_{hex} to slot 0, index 5.

This example also shows:

Function code DE_{hex} (read error) or function code DF_{hex} (write error) in connection with error code 80_{hex}. These cases indicate errors at DP/V1 level.

There are also more general DP/V1 error codes, which can be found in EN 50170, PROFIBUS Guideline 2.082.

IL PB BK DP/V1

Example 7:
Reading with invoke ID
(reading object 1090h, subindex 1, invoke ID 4 on an IB IL POS 200)

Write request (master -> slave)

Data	Data structure
5F 02 2F 0A 04 01 77 88 99 AA 10 90 BB 01	Write/Slot/Index/Total length of data/Invoke ID/Read PCP/ Reserved/Reserved/Reserved/Reserved/Index high/Index low/ Reserved/Subindex

Write response (slave -> master)

Data	Data structure
5F 02 2F 0A	Write/Slot/Index/Length

Read request (master -> slave)

Data	Data structure
5E 02 2F 40	Read/Slot/Index/Maximum length

Read response (slave -> master)

Data	Data structure
5E 02 2F 0A 04 01 77 88 41 04 22 22 22 22	Read/Slot/Index/Length/Invoke ID (mirrored)/Read PCP/Reserved/Reserved/Reserved/Length of PCP data/4 bytes of PCP data

Acyclic communication (DP/V1 and PCP)

**Example 8:
Writing with invoke ID
(writing object 1090h, subindex 1, invoke ID 1 on an IB IL POS 200)**

Write request (master -> slave)

Data	Data structure
5F 02 2F 10 01 02 77 88 99 AA 10 90 BB 01 00 04 11 11 11 11	Write/Slot/Index/Total length of data/Invoke ID/Write PCP/ Reserved/Reserved/Reserved/Reserved/Index high/Index low/ Reserved/Subindex/Reserved/Length of PCP data/4 bytes of object data

Write response (slave -> master)

Data	Data structure
5F 02 2F 10	Write/Slot/Index/Length

Read request (master -> slave)

Data	Data structure
5E 02 2F 40	Read/Slot/Index/Maximum length

Read response (slave -> master)

Data	Data structure
5E 02 2F 04 01 02 77 88	Read/Slot/Index/Length/Invoke ID (mirrored)/Write PCP/Reserved/Reserved



If you wish to transmit the invoke ID, index 47_{dec} must be used.

3.5 PCP communication via process data (C1 master in DP/V0 mode)

DP/V1 communication is relatively new. However, the service life of control systems and plants is so long that extensions and modifications are made. In many cases, the control system is not DP/V1-compatible, but is expected to operate complex devices.

Acyclic services

For this purpose, acyclic services can also be operated within the process data, i.e., even a control system that does not have DP/V1 can control more complex interfaces such as IB IL RS 232 or HART (via IB IL AI 2/HART).

For additional information about PCP communication, please refer to "PCP communication basics" on page 3-3 and "Acyclic communication in DP/V1 mode" on page 3-5.

3.5.1 Mechanism for transmission in the process data

VC1 module

Transmission is via a virtual C1 module (VC1 module). A C1 module should be selected in the hardware configurator in the same way as "normal" I/O terminals and therefore specified in the configuration and parameter telegram.

The VC1 module is only a virtual device because the process data can be used to transmit communication data (PCP) and is not linked to a specific module. During active process data exchange, it is possible to assign the VC1 module sequentially to different terminals with communication objects and to exchange parameter data parallel to the process data.

Process data width

The process data width occupied by the VC1 module in the process data channel can be selected from 4 to 16 words in increments of 2 words. This means that communication objects can be used even if resources are limited. If there are sufficient free resources, a data width of up to 16 words can be used, providing the same ease of operation as for DP/V1 communication.



The VC1 module (listed in the GSD as "PD-PCP x words") may only be configured once in the first position after the bus coupler. It is not linked to any hardware, so a terminal is not actually inserted.

As the data width of the VC1 module is between 4 and 16 words, but the user data can be up to 58 bytes (29 words) per communication, it may be necessary to split the data and transmit it in several steps.

This leads to:

- Start fragment
- Continue fragment
- End fragment
- Error or abort fragment

Each fragment contains a service byte, which is used for the precise assignment of the fragment. The individual fragments and the service byte are explained in detail in the following.

Acyclic communication (DP/V1 and PCP)**Start fragment:**

- Byte 1:** Service
Byte 2: Module number
Byte 3: Index high
Byte 4: Index low
Byte 5: Subindex
Byte 6: Length, if required
Byte 7: Data block, if required
 ...
Byte n: Data block, if required

Table 3-8 Byte 1 - Service in start fragment:

Byte 1							
7	6	5	4	3	2	1	0
Request/ Response	0	0	Fragmentation	Action			

Bit 7: Request/response

0 = Request

1 = Response

Bits 6 to 5: Fragment type

00 = Start fragment

Bit 4: Fragmentation

0 = Not fragmented

1 = Fragmented

Bits 3 to 0: Action00_{hex} No action (clear)01_{hex} Read PCP (I/O terminal)02_{hex} Write PCP (I/O terminal)03_{hex} Read (bus coupler)04_{hex} Write (bus coupler)05_{hex} Read PDU length (displayed in bytes)06_{hex} Read PCP with invoke ID (I/O terminal)07_{hex} Write PCP with invoke ID (I/O terminal)08_{hex} to 0F_{hex} Reserved

In the start fragment, specify the invoke ID for actions 6 and 7 (read/write with the invoke ID) after the terminal number. Bytes 3 to n are then specified at byte 4 onwards.



Please note that actions 01_{hex} and 02_{hex}, and 06_{hex} and 07_{hex} refer to PCP, i.e., these commands can be used to access PCP terminals. Actions 03_{hex} and 04_{hex} are used to read or write objects on the bus coupler (object indices 2 to 5). Please also refer to "Assignment of data" on page 3-5.

Continue fragment:

- Byte 1:** Service
Byte 2: Data block, if required
 ...
Byte n: Data block, if required

Table 3-9 Byte 1 - Service in continue fragment:

Bit 7: Request/response

0 = Request

1 = Response

Bits 6 to 5: Fragment type

01 = Continue fragment

Bits 4 to 0: Counter

01_{hex} to 0F_{hex} Fragment number. If more fragments are required, continue with 0 after 1F_{hex}.

Acyclic communication (DP/V1 and PCP)**End fragment:****Byte 1:** Service**Byte 2:** Data block, if required

...

Byte n: Data block, if required

Table 3-10 Byte 1 - Service in end fragment:

Byte 1							
7	6	5	4	3	2	1	0
Request/ response	1	0	Reserved				

Bit 7: Request/response

0 = Request

1 = Response

Bits 6 to 5: Fragment type

10 = Last fragment (end fragment)

Bits 4 to 0: Reserved

Abort/error fragment:

- Byte 1:** Service
Byte 2: Error code, if required
 ...
Byte n: Error code, if required

Table 3-11 Byte 1 - Service in abort/error fragment:

Byte 1								
7	6	5	4	3	2	1	0	
Request/ response	1	1	Reserved					

Bit 7: Request/response

0 = Request

1 = Response

Bits 6 to 5: Fragment type

11 = Abort/error fragment

Bits 4 to 0: Reserved

Communication can be reset with 60_{hex} so that all buffers involved in the communication are set to their initial status.



When a service has been completed, this should be acknowledged (clear) with service 00 (the other bytes of the VC1 module are then "don't cares"). A handshake is implemented, which indicates to the PROFIBUS DP/V1 bus coupler that the result has been received by the master. The VC1 module can then receive the next service.

Acyclic communication (DP/V1 and PCP)

A response is also sent after every request. This response indicates that the request has been received and shows its current status:

Response structure:

- Byte 1:** Service (response bit is set)
- Byte 2:** Status, if required
- Byte 3:** Length, only on first read response
- ...
- Byte n:** Data block, if required

The status is indicated when local PCP transmission is complete and in the event of an error. In the event of an error, the data block can provide details. An error has occurred if the value of the status byte does not equal 00_{hex}.

00 _{hex}	No error
44 _{hex}	PCP module error
Other errors	See "Error codes for DP/V1 and VC1 communication" on page A-12

For VC1, the parameters have the following meaning:

- <Module number>

The bus coupler counts as module 0, the first configured terminal as 1, the second as 2, etc. Please note that only devices with diagnostics should be configured and are "active" devices in the station.

- <Index high and Index low>

This specifies the object index of the addressed object in two bytes. This also applies for objects on the bus coupler. For example, for index 5FE0_{hex} the value 5F_{hex} should be entered for Index high and the value E0_{hex} should be entered for Index low. For index 4_{hex} on the bus coupler, 00_{hex} is Index high and 04_{hex} is Index low.

- <Subindex>

When working with a PCP object, the subindex can be used to select a specific element from an array or record. The bus coupler has no arrays or records, so subindex 0 should be specified.

- <Length>

This value specifies how many bytes of object data (object contents) follow. Depending on the terminal, this may be bus coupler object data or I/O terminal object data.

IL PB BK DP/V1

- <Data block>

This is only the contents of an object. The length and scope of the data has already been described by the <Length> parameter.

- <Invoke ID>

The invoke ID is one byte in length and is used for channel selection on some terminals.

To aid understanding, the same examples as for DP/V1 services are used in the following section. This means that the description of the examples for DP/V1 communication is valid again here, see "Examples" on page 3-9. See also "Error codes for DP/V1 and VC1 communication" on page A-12.

3.5.2 Examples for VC1 services**1. Reading the connected local PCP devices and their status
(slot 0, index 5 on the bus coupler)**

Read request (master -> slave)

Data (4 words VC1)	Data structure
03 00 00 05 00 00 00 00	Read/Slot/Index high/Index low/Subindex 3 bytes unused

Read response (slave -> master)

Data (4 words VC1)	Data structure
83 00 03 03 01 00 00 00	Read response/Status/Actual length/3 bytes of object data 2 bytes unused

Clear request (master -> slave)

Data (4 words VC1)	Data structure
00 xx xx xx xx xx xx xx	Clear

Clear response (slave -> master)

Data (4 words VC1)	Data structure
00 00 00 00 00 00 00 00	Clear response

Acyclic communication (DP/V1 and PCP)

2. Reading object 5FFF, subindex 2 of an IB IL RS 232 at slot 3

Read request (master -> slave)

Data (4 words VC1)	Data structure
01 03 5F FF 02 00 00 00	Read PCP/Slot/Index high/Index low/Subindex 3 bytes unused

Read response (slave -> master)

Data (4 words VC1)	Data structure
81 00 01 07 00 00 00 00	Read response/Status/Actual length/1 byte of object data 4 bytes unused

Clear request (master -> slave)

Data (4 words VC1)	Data structure
00 xx xx xx xx xx xx xx	Clear

Clear response (slave -> master)

Data (4 words VC1)	Data structure
00 00 00 00 00 00 00 00	Clear response

**3. Manual acknowledgment of peripheral faults
(writing to the bus coupler, slot 0, index 4)**

Write request (master -> slave)

Data (4 words VC1)	Data structure
04 00 00 04 00 01 02 00	Write/Slot/Index high/Index low/Subindex Length/Data 1 byte unused

Write response (slave -> master)

Data (4 words VC1)	Data structure
84 00 00 00 00 00 00 00	Write response/Status 6 bytes unused

Clear request (master -> slave)

Data (4 words VC1)	Data structure
00 xx xx xx xx xx xx xx	Clear

Clear response (slave -> master)

Data (4 words VC1)	Data structure
00 00 00 00 00 00 00 00	Clear response

IL PB BK DP/V1**4. Writing to object 5FFF, subindex 0 of an IB IL RS 232 at slot 3**

Write request (master -> slave) - Start fragment

Data (4 words VC1)	Data structure
12 03 5F FF 00 14 00 06	Write PCP/Slot/Index high/Index low/Subindex/Length/2 bytes of data

Write response (slave -> master)

Data (4 words VC1)	Data structure
12 I 00 00 00 00 00 00 00	Write response/7 bytes unused

Write request (master -> slave) - 1st continue fragment

Data (4 words VC1)	Data structure
21 02 00 00 24 0D 0A 00	Write/7 bytes of data

Write response (slave -> master)

Data (4 words VC1)	Data structure
21 I 00 00 00 00 00 00 00	Write response I 7 bytes unused

Write request (master -> slave) - 2nd continue fragment

Data (4 words VC1)	Data structure
22 00 00 00 11 13 00 00	Write/7 bytes of data

Write response (slave -> master)

Data (4 words VC1)	Data structure
22 I 00 00 00 00 00 00 00	Write response I 7 bytes unused

Write request (master -> slave) - End fragment

Data (4 words VC1)	Data structure
40 00 00 00 00 I 00 00 00	Write/4 bytes of data I 3 bytes unused

Write response (slave -> master)

Data (4 words VC1)	Data structure
82 00 I 00 00 00 00 00 00	Write response/Status I 6 bytes unused

Acyclic communication (DP/V1 and PCP)

Clear request (master -> slave)

Data (4 words VC1)	Data structure
00 xx xx xx xx xx xx xx	Clear

Clear response (slave -> master)

Data (4 words VC1)	Data structure
00 00 00 00 00 00 00 00	Clear response

Write response with service 82_{hex} is in this case the acknowledgment of write request with 12_{hex} in the start fragment.

IL PB BK DP/V1

**5. In the event of an error:
Reading a non-existent object on an I/O terminal with PCP functions
(access to 5C00, subindex 0 on an IB IL RS 232, slot 3)**

Read request (master -> slave)

Data (4 words VC1)	Data structure
01 03 5C 00 00 00 00 00	Read PCP/Slot/Index high/Index low/Subindex 3 bytes unused

Write response (slave -> master)

Data (4 words VC1)	Data structure
81 44 06 07 00 00 00 00	Read response/Status/4 bytes of error code 4 bytes unused

Abort request (master -> slave)

Data (4 words VC1)	Data structure
60 xx xx xx xx xx xx xx	Abort

Abort response (slave -> master)

Data (4 words VC1)	Data structure
E0 00 00 00 00 00 00 00	Abort response

Clear request (master -> slave)

Data (4 words VC1)	Data structure
00 xx xx xx xx xx xx xx	Clear response

Clear response (slave -> master)

Data (4 words VC1)	Data structure
00 00 00 00 00 00 00 00	Clear response

44hex in the read response of the start fragment indicates an error. 06hex and 07hex in this case is the error code, which according to the PCP description indicates that the addressed index does not exist, see also "Error codes for PCP communication" on page A-13.



Communication can be reset with 60_{hex} so that all buffers involved in the communication are set to their initial status.

Acyclic communication (DP/V1 and PCP)

**6. In the event of an error:
 Reading an object on an I/O terminal without PCP functions (access to 5FF0,
 subindex 0 on an IB IL DO 8, slot 2)**

Read request (master -> slave)

Data (4 words VC1)	Data structure
01 02 5F F0 00 00 00 00	Read PCP/Slot/Index high/Index low/Subindex I 3 bytes unused

Read response (slave -> master)

Data (4 words VC1)	Data structure
81 D2 00 00 00 00 00 00	Read response/Status or 2 bytes of error code I 5 bytes unused

Abort request (master -> slave)

Data (4 words VC1)	Data structure
60 xx xx xx xx xx xx xx	Abort

Abort response (slave -> master)

Data (4 words VC1)	Data structure
E0 00 00 00 00 00 00 00	Abort response

Clear request (master -> slave)

Data (4 words VC1)	Data structure
00 xx xx xx xx xx xx xx	Clear

Clear response (slave -> master)

Data (4 words VC1)	Data structure
00 00 00 00 00 00 00 00	Clear response

D2_{hex} in the read response indicates an error. An error has occurred if the second byte of the response (status byte) does not equal 0, see also "Error codes for DP/V1 and VC1 communication" on page A-12



Communication can be reset with 60_{hex} so that all buffers involved in the communication are set to their initial status.

IL PB BK DP/V1**7. Fragmented read on IB IL RS 232, slot 3, object 5FFF, subindex 0
(additional example)**

Read request (master -> slave) - Start fragment

Data (4 words VC1)	Data structure
01 03 5F FF 00 00 00 00	Read PCP/Slot/Index high/Index low/Subindex 3 bytes unused

Read response (slave -> master)

Data (4 words VC1)	Data structure
91 00 14 00 07 02 00 00	Read response/Status/Actual length/5 bytes of object data

Read request (master -> slave) - Start fragment acknowledgment

Data (4 words VC1)	Data structure
91 xx xx xx xx xx xx xx	Read/7 bytes unused

Read response (slave -> master)

Data (4 words VC1)	Data structure
A1 24 0D 0A 00 00 00 00	Read response/7 bytes of object data

Read request (master -> slave) - acknowledgment of 1st continue fragment

Data (4 words VC1)	Data structure
A1 xx xx xx xx xx xx xx	Read/7 bytes unused

Read response (slave -> master)

Data (4 words VC1)	Data structure
A2 11 13 00 00 00 00 00	Read response/7 bytes of object data

Read request (master -> slave) - acknowledgment of 2nd continue fragment

Data (4 words VC1)	Data structure
A2 xx xx xx xx xx xx xx	Read/7 bytes unused

Read response (slave -> master)

Data (4 words VC1)	Data structure
C0 00 00 00 00 00 00 00	Read/1 byte of object data 6 bytes unused

Acyclic communication (DP/V1 and PCP)

Read request (master -> slave) - End fragment acknowledgment

Data (4 words VC1)	Data structure
C0 xx xx xx xx xx xx x	Read/7 bytes unused

Read request (master -> slave)

Data (4 words VC1)	Data structure
00 xx xx xx xx xx xx xx	Clear

Read response (slave -> master)

Data (4 words VC1)	Data structure
00 00 00 00 00 00 00 00	Clear response

IL PB BK DP/V1

**8. Reading with invoke ID
(reading object 1090h, subindex 1, invoke ID 4 on an IB IL POS 200)**

Read request (master -> slave)

Data	Data structure
06 02 04 10 90 01	Read PCP with invoke ID/Slot/Invoke ID/Index high/Index low/Subindex

Read response (slave -> master)

Data	Data structure
86 00 04 22 22 22 22	Read response/Status/Actual length/4 bytes of data

**9. Writing with invoke ID
(writing object 1090h, subindex 1, invoke ID 1 on an IB IL POS 200)**

Write request (master -> slave)

Data	Data structure
07 02 01 10 90 01 04 11 11 11 11	Write PCP with invoke ID/Slot/Invoke ID/Index high/Index low/Subindex/Length of PCP data/4 bytes of data

Write response (slave -> master)

Data	Data structure
87 00 00 00 00 00 00 00	Write response/Status/6 bytes unused



Once each service is complete (even after an abort in the event of an error), acknowledge it with 0 (on byte 0).

On a read action, the master sends an acknowledgment to indicate to the slave that it has received the last data packet and the slave can send the next data packet.

On a write action, the slave sends an acknowledgment to indicate to the master that it has received the last data packet and the master can send the next data packet.

4 Dynamic configuration

Dynamic configuration is the specification and configuration of a maximum configuration. Any subgroup of this maximum configuration can be operated.

In addition to dynamic configuration, empty spaces can be reserved for future extensions.

4.1 Empty spaces

It can be helpful to reserve empty spaces for a station, which may be used at different configuration levels. You can configure the maximum configuration level and thus also reserve memory in the PLC. However, optional terminals do not have to be connected. They can be deactivated in the configuration.

If the station is subsequently extended to include previously deactivated terminals, the new terminals can be connected and activated in the hardware configurator.

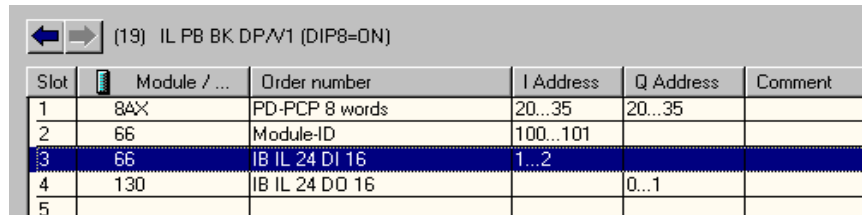

Slot	Module / ...	Order number	I Address	Q Address	Comment
1	84X	PD-PCP 8 words	20...35	20...35	
2	66	Module-ID	100...101		
3	66	IB IL 24 DI 16	1...2		
4	130	IB IL 24 DO 16		0...1	
5					

Figure 4-1 Configuration table in the STEP 7[®] hardware configurator

The configuration, e.g., in STEP 7[®], is carried out in the same way as for other modular slaves. The configuration can be created from the hardware catalog using drag & drop, see Figure 4-1.

Open the "Properties" dialog box by double-clicking on a terminal.

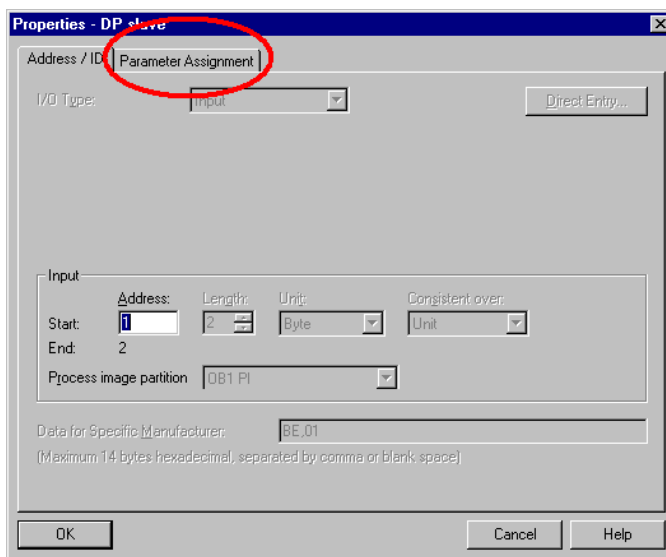

Figure 4-2 "Properties" dialog box of the IB IL 24 DI 16

The "Parameter Assignment" tab can be used to specify whether a terminal should be active or inactive, see Figure 4-3.



Please note that adjustments to the configuration and actual structure are also carried out for inactive terminals. A message is displayed if deactivated terminals are connected.

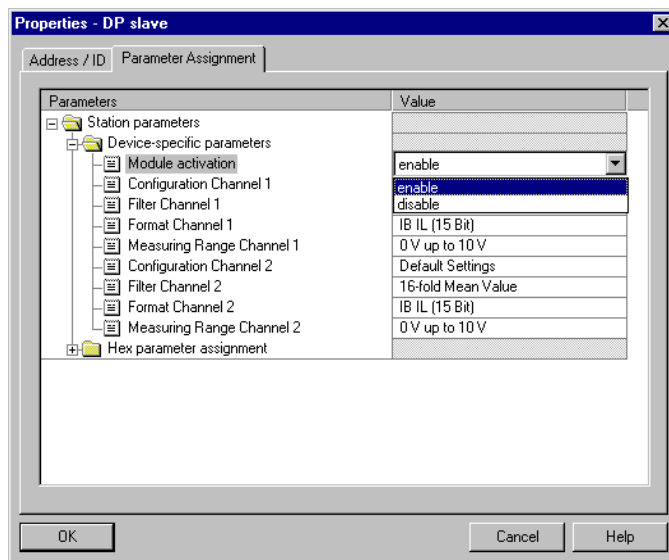

Figure 4-3 Activating/deactivating a terminal

Dynamic configuration

Following activation/deactivation, the configuration can be saved, translated, and downloaded as usual.

Depending on the terminal type, safety-related values (DO and AO) to be output in the event of an error can also be set at this point, for example. Furthermore, inputs (AI) can be parameterized. This is also carried out via the dialog box shown in Figure 4-3.

4.2 Dynamic configuration

In dynamic configuration, a maximum configuration is specified during configuration. The addresses are thus reserved in the PLC. Any subgroup of this maximum configuration can be operated. The advantage is that several stations with the same device number but different configurations can be used in the field, although only one such station can ever be active on PROFIBUS.

Three indices on the IL PB BK DP/V1-PAC are used:

Index 6: Activation/deactivation of terminals and slots

Access: Read and write



Index 6 is stored retentively.

Structure: Length of 8 bytes

Byte 1								Byte 2								Bytes 3 ... 7					Byte 8							
8	7	6	5	4	3	2	1	16	15	14	13	12	11	10	9	...	x	63	62	61	60	59	58	57				

Bit = 1: Terminal and slot inactive

Bit = 0: Terminal and slot active

Index 7: Read back active/inactive terminals and slots

Access: Read



Index 7 indicates which terminals are active/inactive. Deactivation via the parameter telegram (reservation of empty spaces) is also indicated here.

Structure: Length of 8 bytes

Byte 1								Byte 2								Bytes 3 ... 7					Byte 8							
8	7	6	5	4	3	2	1	16	15	14	13	12	11	10	9	...	x	63	62	61	60	59	58	57				

Bit = 1: Terminal and slot inactive

Bit = 0: Terminal and slot active



Empty spaces configured in the parameter telegram are logically ORed with inactivation via index 6.

Index 8: Read/write ID

Access: Read and write

Structure: Length of 2 bytes



Each IL PB BK DP/V1 can be assigned an individual ID. This ID is stored retentively and can be used to identify a station if it was disconnected from the power supply. This means that several stations can be operated alternately under the same station address in PROFIBUS. The ID can also be read cyclically in the process data.

4.3 Startup

DIP switch position 8 = ON is recommended for new projects, as this corresponds to the default parameterization options.

4.3.1 Planning configuration

Figure 4-4 shows an example of the maximum configuration, as provided. All terminals are activated by default.

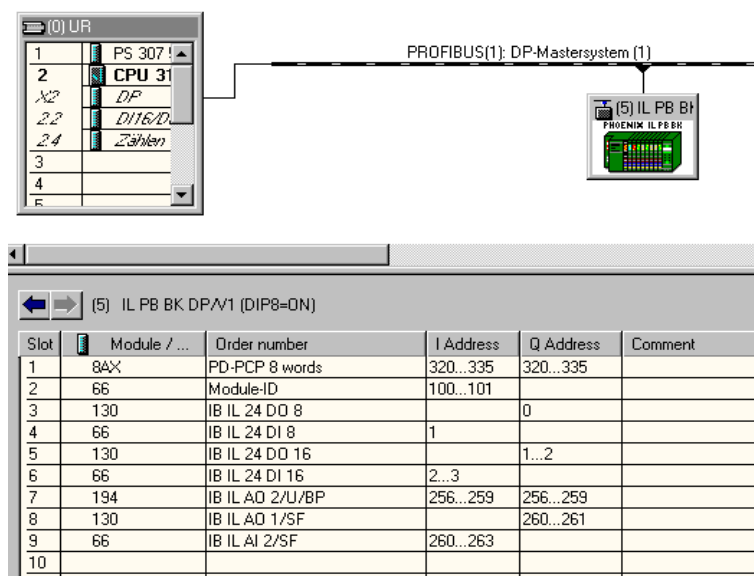

Figure 4-4 Configuration in the STEP 7[®] hardware configurator

Access to the indices described on page 4-4 can be enabled via PROFIBUS DP/V1 or even via DP/V0. This means that the indices can also be addressed via normal process data. This example only describes access via process data.

To access indices 6 to 8 via process data, configure the "PD-PCP x words" terminal (x = 4, 6, ..., 16) as the first terminal in the station. The data width and address can be selected according to the options in the CPU.

The "Module-ID" module is used to read the individually definable ID of the PROFIBUS DP/V1 bus coupler (index 8).

It does not have to be configured. However, if it is configured, it must be placed directly after "PD-PCP x words", i.e., in the second position or the first position if no "PD-PCP x words" module was configured.

Configure the remaining terminals as usual, once you have proceeded as described in "Specifying the active configuration" on page 4-8.

4.3.2 Options for specifying the active configuration

In the following example, the 16-channel digital terminals and the single-channel analog output terminal should not be part of the station, i.e., these terminals are part of the maximum configuration, but should be deactivated at this station. An entirely different subgroup of the maximum configuration could thus be active at another station. This means that stations with different subgroups can be docked at PROFIBUS and run with their individual configurations.

There are three options for startup:

1 Via DP/V1

This option is very user-friendly but should not be considered further as the master used in this example is a CPU315 2-DP without DP/V1 capability.

2 Via DP/V0 with maximum configuration and configured empty spaces

Empty spaces remain free. The active configuration can be modified via DP/V0 and the deactivation can then be undone from the configuration. Proceed as follows:

- Deactivate DI16, DO16, and AO1 in the hardware configuration and download the hardware configuration.
- You can switch to cyclic data exchange and the configuration connected to the station can be set retentively via index 6.
- Reactivate the terminals that were deactivated in the hardware configurator (translate and download hardware configurator).

In addition to the parameter telegram, index 6 is taken into consideration for all subsequent startups.

3 Via DP/V0 with minimum configuration

Only the terminal for accessing indices 6 to 8 via the process data channel is configured initially. In fact, any structure can be connected. Configuration settings can be made subsequently.

- In the hardware configuration select only the "PD-PCP x words" module and download it. The actual connected structure is of no importance here (at least one terminal must be connected).
- Switch to cyclic data exchange and retentively set the configuration connected to the station via index 6.
- Enter configuration settings in the hardware configurator.

The third option is particularly suitable for startup. All the hardware can be plugged in together. You only need to transmit the hardware configuration once on startup if "PD-PCP x words" is the only module configured. Briefly switch to the RUN state and transmit the data for index 6 and 8. The terminal can be clearly identified later by assigning an ID to index 8.

The configuration for the maximum configuration can then be completed.

The following describes the individual steps for startup via DP/V0 with minimum configuration.

4.3.3 Specifying the active configuration

- 1 Specify the address on the station using DIP switches 1 to 7 and select the operating mode using DIP switch 8 = ON.

Connect the terminals, which represent the subgroup of the maximum configuration. In the hardware configurator, configure only the "PD-PCP x words" module (recommendation: $x \geq 8$).

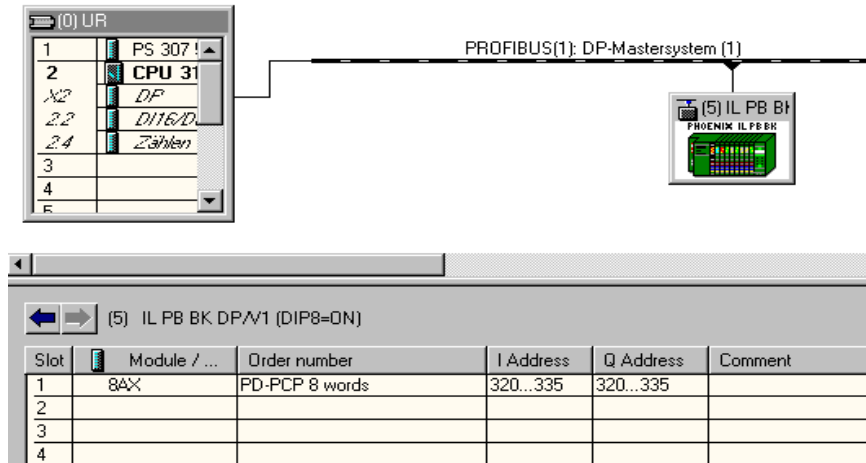

Figure 4-5 Specifying the "PD-PCP 8 words" module

The address can be freely defined in the PLC memory within the framework of the options provided by the PLC. The terminal has no specific requirements.

- 2 Specify the active configuration.

In the example, terminals 3 (IB IL 24 DO 16), 4 (IB IL 24 DI 16), and 6 (IB IL 24 AO 1) should be deactivated. According to the description of index 6, the value is 2C 00 00 00 00 00 00.

Write request (master -> slave)

Data (8 words VC1)	Data structure
04 00 00 06 00 08 2C 00 00 00 00 00 00 00 01 00 00	Write/Slot/Index high/Index low/Subindex/Length/Data 2 bytes unused

Write response (slave -> master)

Data (8 words VC1)	Data structure
84 00 01 00 00 00 00 00 00 00 00 00 00 00 00 00	Write response/Status 14 bytes unused

Clear request (master -> slave)

Data (8 words VC1)	Data structure
00 xx xx xx xx xx xx xx xx xx xx xx xx xx xx	Clear

Clear response (slave -> master)

Data (8 words VC1)	Data structure
00 00 00 00 00 00 00 00 00 00 00 00 00 00 00 00	Clear response

You have thus specified which slots should be active and which should be inactive.

3 Specify an ID.

2 bytes are available for an ID. This corresponds to 65,536 options for identifying the terminal retentively. If terminals with the same PROFIBUS address are connected alternately, this makes it easy to identify terminals after power up.

The ID is stored on index 8.

Example ID: 2633

Write request (master -> slave)

Data (8 words VC1)	Data structure
04 00 00 08 00 02 26 33 00 00 00 00 00 00 00 00	Write/Slot/Index high/Index low/Subindex/Length/Data 8 bytes unused

Write response (slave -> master)

Data (8 words VC1)	Data structure
84 00 00 00 00 00 00 00 00 00 00 00 00 00 00 00	Write response/Status 14 bytes unused

Clear request (master -> slave)

Data (8 words VC1)	Data structure
00 xx xx xx xx xx xx xx xx xx xx xx xx xx xx	Clear

Clear response (slave -> master)

Data (8 words VC1)	Data structure
00 00 00 00 00 00 00 00 00 00 00 00 00 00 00 00	Clear response

IL PB BK DP/V1

4 Create the entire configuration.

In this step, the hardware configuration is completed and downloaded.

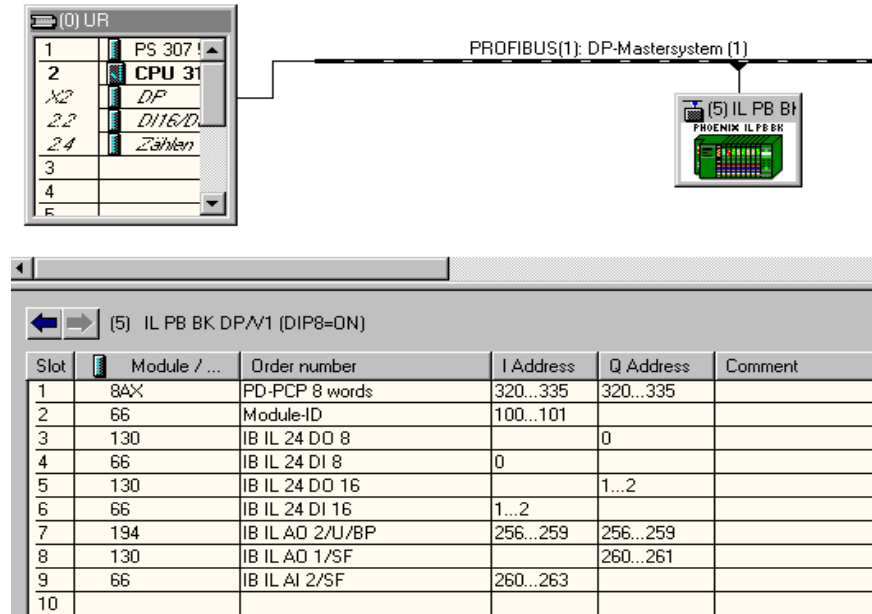

Figure 4-6 Configuration in the STEP 7[®] hardware configurator

The IB IL 24 DO 16-PAC, IB IL 24 DI 16-PAC, and IB IL 24 AO1-PAC terminals are deactivated and must not be inserted.



The "PD-PCP x words" module does not have to be configured for normal operation. This is only necessary if you wish to access indices.



The station ID (Module-ID) at index 8 can also be read in the normal process data, see Figure 4-6.



If you wish to use the "PD-PCP x words" and "Module-ID" modules, you must configure them first. The "PD-PCP x words" module has priority over the "Module-ID" module.

4.4 Modifying the station structure

Two options are available if you wish to modify the station structure.

- 1 Proceed as described in Section 4.3.
- 2 Use the "PD-PCP x words" module in the old configuration to activate/deactivate terminals:
 - Step 2 on page 4-8 to specify a new subgroup
 - Step 3 on page 4-9 to specify a new ID
 - Subsequent modification of the station

IL PB BK DP/V1

5 What to do in the event of an error

General

Errors can occur during startup of the Inline station as well as when PROFIBUS is in operation. There are basically two ways of detecting errors. One way errors can be detected is by using local diagnostics with the help of the LEDs on the PROFIBUS DP/V1 bus coupler and the Inline terminals, FLM branch terminal, and AS-i modules. Alternatively, all types of errors are sent from the PROFIBUS DP/V1 bus coupler to the PROFIBUS master via the PROFIBUS diagnostic telegram so that errors in the station can also be diagnosed and rectified using software.

Optional: PROFIBUS DP master simulator

In addition to the basic diagnostic options, special startup software can be used for pre-function testing of the Inline station with the PROFIBUS DP/V1 bus coupler.

An example of this type of software is the PROFIBUS DP master simulator (PB ECO LINK) from Phoenix Contact. It can be used to operate and test the PROFIBUS DP/V1 bus coupler using PROFIBUS. It is possible to test Inline terminals, the FLM branch terminal, and AS-i modules connected to the PROFIBUS DP/V1 bus coupler to ensure they are connected and operating correctly.

The PROFIBUS DP master simulator is a simple, universal program for data exchange with the PROFIBUS DP/V1 bus coupler via PROFIBUS DP. It is possible to read input data and write output data.

A V.24 (RS-232)/PROFIBUS converter is supplied as standard with the PROFIBUS DP master simulator. The converter is very compact and does not require an external power supply. Therefore, it is also suitable for mobile use with a laptop or notebook. The V.24 (RS-232)/PROFIBUS converter is inserted between the PROFIBUS DP/V1 bus coupler and the V.24 (RS-232) connecting cable, which is connected to the V.24 (RS-232) interface of the PC.

5.1 Local diagnostics

The diagnostic and status indicators of the terminal enable quick local error diagnostics. They are clearly visible on the front of the terminal.

Diagnostics

The diagnostic indicators are red and green LEDs. They indicate the type and location of the error.

A terminal is operating correctly if all of its green LEDs are on.

Once an error has been removed, the indicators immediately display the current status.

Status

The status indicators (yellow) indicate the status of the relevant input/output and the connected device.

The diagnostic and status indicators and the resulting error analysis for the PROFIBUS DP/V1 bus coupler are described below.



If you wish to use the "PD-PCP x words" and "Module-ID" modules, you must configure them first. The "PD-PCP x words" module has priority over the "Module-ID" module.

5.1.1 Diagnostic and status indicators on the PROFIBUS DP/V1 bus coupler

For additional information about diagnostic and status indicators, please refer to "Diagnostics on the PROFIBUS DP/V1 bus coupler" on page 2-15.

5.1.2 Error causes and remedies on the PROFIBUS DP/V1 bus coupler



Each combination of LEDs on the PROFIBUS DP/V1 bus coupler indicates a specific error, which can then be localized and removed.

The various LED combinations are described in Table 5-1. The symbols used have the following meaning:

Symbol	Meaning
○	LED OFF
⊙	LED flashing
●	LED ON

Table 5-1 Possible LED combinations

No.	UM	US	BF	FS	FN	Error	
1	○	○	○	○	○	Voltage supply U_M and U_S not present	Check voltage supply U_M and U_S
2	○	●	○	○	○	Voltage supply U_M not present	Check voltage supply U_M
3	●	○	○	○	○	Voltage supply U_S not present	Check voltage supply U_S
4	●	●	○	○	○	No error, everything OK	
5	●	●	●	○	○	No communication on PROFIBUS	<ul style="list-style-type: none"> - Correct PROFIBUS address on bus coupler - Correct PROFIBUS master settings - Remove PROFIBUS cable fault
6	●	●	○	●	⊙	Number of flashing pulses at FN indicates the type of error	See 5.1.3
7	●	●	○	○	⊙	Number of flashing pulses at FN, indicates the error number	See 5.1.3
8	●	●	⊙	○	○	Safety values are being output	Switch master to RUN state, check communication with master Set "Data exchange mode" parameter on the bus coupler to "Data exchange without operate"



Never make any changes to the configuration during operation. Always switch off the Inline station first.

5.1.3 Determining the error cause and remedy

The error type and the error number can be determined using the **FS** and **FN** LEDs on the PROFIBUS DP/V1 bus coupler.

- FS ON: The number of flashing pulses at FN indicates the error type.
- FS OFF: The number of flashing pulses at FN indicates the error number.



For additional information about the individual error codes, please refer to "Error description" on page A-1.

Example

The FS LED is on and the FN LED flashes three times simultaneously. The FS LED goes out and the FN LED flashes four times. The error is caused by the use of a Loop 1 module that is not permitted.

Locating an error

The diagnostic and status indicators of Inline terminals enable clear error localization. An error is displayed in the station. In addition, the device on which the error has occurred is reported to the control system and can be read there (e.g., using the STEP 7[®] SIMATIC[®] Manager).

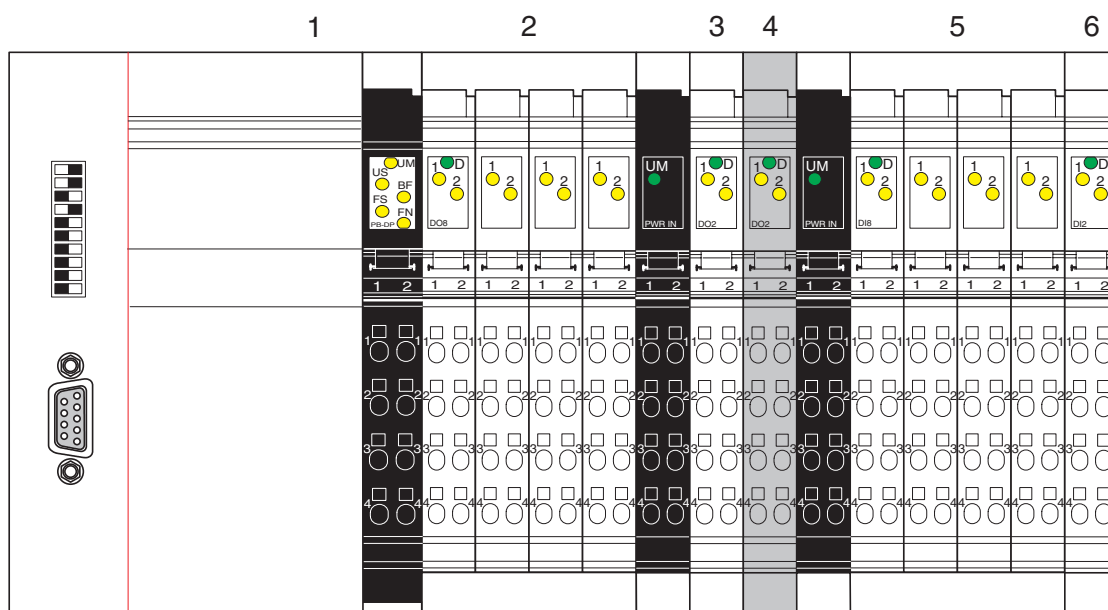

6138A031

Figure 5-1 Example station for error localization

Terminals used in the example station:

- | | | | |
|---|----------------------|---|----------------------|
| 1 | IL PB BK DP/V1-PAC | 4 | IB IL 24 DO 2-2A-PAC |
| 2 | IB IL 24 DO 8-PAC | 5 | IB IL 24 DI 8-PAC |
| 3 | IB IL 24 DO 2-2A-PAC | 6 | IB IL 24 DI 2-PAC |

IL PB BK DP/V1

IB IL 24 PWR IN-PAC power terminals are not numbered because they are not bus devices and therefore do not have indicators for error diagnostics.

When the system is operating correctly, the green LEDs on the bus coupler and the other terminals remain lit (Figure 5-2, detail A).

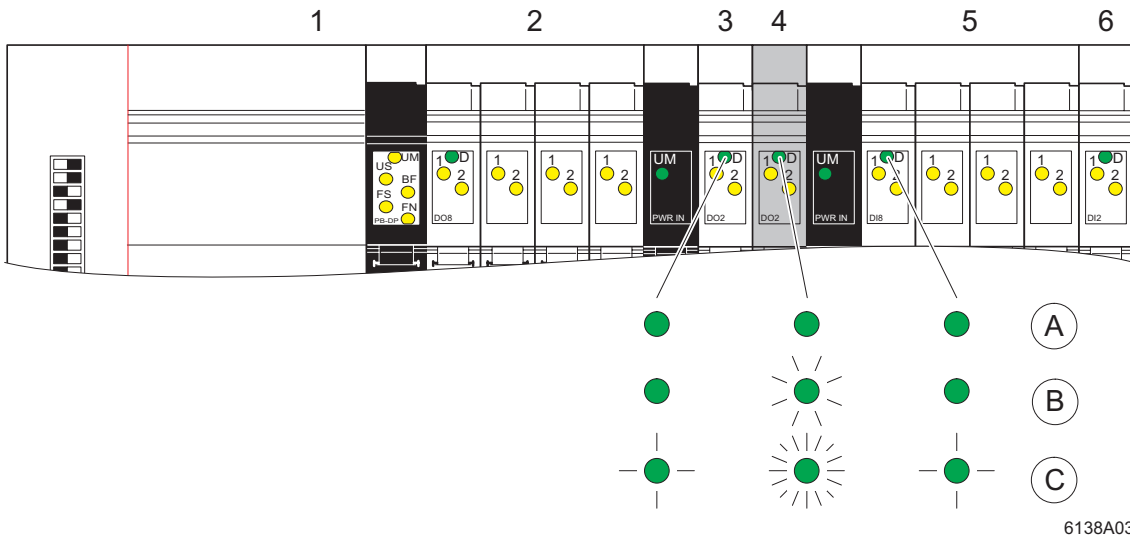

6138A032

Figure 5-2 Station with diagnostic indicators

Figure 5-2 shows a station with possible error states. It shows that a peripheral fault has been detected at terminal 4 and a bus error has been detected between terminal 3 and terminal 4, and shows the behavior of the diagnostic indicators on the adjacent terminals.

- A No error
 - B Peripheral fault, see Table 5-2
 - C Bus error, see Table 5-3
- LED ON or flashing at 0.5 Hz/2 Hz/4 Hz (ON/slow/medium/fast)

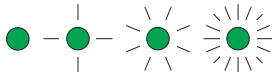

Table 5-2 Peripheral fault

Error:	Short circuit at terminal 4 (IB IL 24 DO 2-PAC)
Effect:	
Control system:	Error message to the control system (peripheral fault)
Bus coupler:	FS and FN flash
Terminal 4:	Green D LED flashes at 2 Hz
Other terminals:	Remain unchanged

Table 5-3 Bus error

Error:	Incoming bus after terminal 3 and before terminal 4 has been interrupted
Effect:	
Control system:	Error can be localized by the control system
Bus coupler:	FS and FN flash
Terminal 4:	Green D LED flashes at 4 Hz (bus error)
Other terminals:	Green D LEDs on all other terminals flash at 0.5 Hz



In firmware Version A (41_{hex}) or later, a peripheral fault triggered by the IB IL 24 SEG/ELF-PAC supply terminal and the IB IL EDI 2-DESINA-PAC input terminal is acknowledged by reading the station diagnostics. The error can also be acknowledged from the application.

5.2 Diagnostics on the PROFIBUS master

The error information sent in the diagnostic telegram from the PROFIBUS DP/V1 bus coupler to the PROFIBUS master can, e.g., be displayed there with STEP 7® software using the SFC13 system function block. For a description of the process, please refer to the documentation for your PROFIBUS diagnostic software. Both "standard diagnostics" and "device-specific diagnostics" are available. The meaning of the individual bytes is provided in Table 5-4 and Table 5-5 (below).

5.2.1 PROFIBUS standard diagnostics

Table 5-4 PROFIBUS standard diagnostics

Byte	Meaning (DIP8 = OFF)	Meaning (DIP8 = ON)
0	Station status 1	Station status 1
1	Station status 2	Station status 2
2	Station status 3	Station status 3
3	PROFIBUS master address	PROFIBUS master address
4	00 _{hex} manufacturer ID high byte	06 _{hex} manufacturer ID high byte
5	F0 _{hex} manufacturer ID low byte	CC _{hex} manufacturer ID low byte

Detailed explanation for station status 1 to 3

Station status 1 to 3 indicates the state of a DP slave.

Table 5-5 Structure of station status 1 (byte 0)

Bit	Value	Meaning, cause	Remedy
0	1	The DP slave is not addressed by the DP master.	Is the correct PROFIBUS address set on the DP slave? Is the bus connector connected? Is there voltage at the DP slave? Is the RS-485 repeater set correctly? Has the DP slave been reset?
1	1	The DP slave is not ready for data exchange.	Wait, because the DP slave is starting up.
2	1	The configuration data sent from the DP master to the DP slave does not match the configuration of the DP slave.	Has the correct station type or the correct DP slave configuration been entered in the configuration software?
3	1	External diagnostics are present (group diagnostic indicator).	Evaluate diagnostics. Once all errors have been removed, bit 3 is reset. The bit is reset when a new diagnostic message is present in the bytes of the above diagnostics.
4	1	The required function is not supported by the DP slave.	Check configuration.

What to do in the event of an error

Table 5-5 Structure of station status 1 (byte 0)

Bit	Value	Meaning, cause	Remedy
5	1	The DP master cannot interpret the response of the DP slave.	Check bus configuration.
6	1	The DP slave type does not match the software configuration.	Is the correct station type specified in the configuration software?
7	1	The DP slave has been parameterized by another DP master (not by the DP master that currently has access to the DP slave).	The bit always has the value 1 if, for example, you access the DP slave with the programming device or another DP master. The PROFIBUS address of the DP master that parameterized the DP slave is located in the "master PROFIBUS address" diagnostic byte.

Table 5-6 Structure of station status 2 (byte 1)

Bit	Value	Meaning
0	1	The DP slave must be reparameterized.
1	1	A diagnostic message has been generated. The DP slave will not operate until the error has been removed (static diagnostic message).
2	1	The bit always has the value 1.
3	1	Response monitoring is activated for this DP slave.
4	1	The DP slave has received the "FREEZE" control command. This bit is only updated if you change another diagnostic message as well.
5	1	The DP slave has received the "SYNC" control command.
6	0	The bit always has the value 0.
7	1	The DP slave is deactivated, i.e., removed from the current process.

Table 5-7 Structure of station status 3 (byte 2)

Bit	Value	Meaning
0 to 6	0	These bits always have the value 0.
7	1	There are more diagnostic messages than the DP slave can save.

5.2.2 PROFIBUS device-specific diagnostics

For additional information about device-specific diagnostics, please refer to "Diagnostics" on page 2-37.

IL PB BK DP/V1

6 Technical data and ordering data



For the technical data for the Inline terminals, FLM and AS-i modules, please refer to the module-specific data sheets.
The technical data does not claim to be complete.
Technical modifications reserved.

6.1 Technical data

General data

Housing dimensions (width x height x depth)	90 mm x 120 mm x 72 mm (with Inline connector)
Weight	210 g (without Inline connector), 240 g (with Inline connector)
Ambient temperature (operation)	-25°C ... +55°C
Ambient temperature (storage/transport)	-25°C ... +85°C
Permissible humidity (operation/storage/transport)	10% ... 95%, according to DIN EN 61131-2
Permissible air pressure (operation/storage/transport)	70 kPa ... 106 kPa (up to 3000 m above sea level)
Degree of protection	IP20
Class of protection	Class III, IEC 61140

Interfaces

PROFIBUS

Copper cable (RS-485), connected via D-SUB shield connector; electrically isolated supply; shielding directly connected to functional earth ground.

System data

Number of devices per station	63, maximum
Total amount of I/O data per station	184 bytes, maximum in compatible mode 176 bytes, maximum in DP/V1 mode
Maximum PROFIBUS DP/V1 bus coupler current for the I/O terminal communications power	2 A at U_L
Maximum permissible current for supplying the analog terminals	0.5 A at U_{ANA}

24 V main supply U_M

Connection method	Spring-cage terminals
Recommended cable lengths	30 m, maximum; do not route cable through outdoor areas
Continuation	Through potential routing
Nominal value	24 V DC
Tolerance	-15%/+20% (according to EN 61 13 1-2)
Ripple	±5%
Permissible range	19.2 V ... 30 V (ripple included)
Typical current consumption of the IL PB BK DP/V1 without Inline devices at nominal voltage	0.11 A DC (no-load operation, i.e., incoming PROFIBUS is plugged in, no Inline devices are connected)

IL PB BK DP/V1

24 V main supply U_M (Continued)

Maximum current consumption of the IL PB BK DP/V1 without Inline devices at nominal voltage	0.15 A DC (no-load operation, i.e., incoming PROFIBUS is plugged in, no Inline devices are connected)
Maximum current consumption at nominal voltage	1.25 A DC, comprising: 0.75 A DC for communications power 0.5 A DC for analog power supply
Safety equipment (for bus coupler supply only)	
Surge voltage	Yes
Polarity reversal	Yes (up to 8 A, maximum)



Provide an external fuse for the 24 V area

This 24 V area must be externally protected. The power supply unit must be able to supply four times the nominal current of the external fuse, to ensure that it trips in the event of an error.

24 V segment supply U_S

Connection method	Spring-cage terminals
Recommended cable lengths	30 m, maximum; do not route cable through outdoor areas
Continuation	Through potential routing
Nominal value	24 V DC
Tolerance	-15%/+20% (according to EN 61 13 1-2)
Ripple	±5%
Permissible range	19.2 V DC ... 30 V DC (ripple included)
Current carrying capacity	8 A, maximum
Safety equipment	
Surge voltage	Yes
Polarity reversal	Yes



Provide an external fuse for the 24 V area

This 24 V area must be externally protected. The power supply unit must be able to supply four times the nominal current of the external fuse, to ensure that it trips in the event of an error.

Power dissipation

Formula to calculate the power dissipation of the electronics

$$P_{TOT} = P_{BUS} + P_{PERI}$$

$$P_{TOT} = 2.3 \text{ W} + \left(1.4 \frac{\text{W}}{\text{A}} \times \sum_{n=1}^a I_{Ln}\right) + \left(0.7 \frac{\text{W}}{\text{A}} \times \sum_{m=1}^b I_{Lm}\right)$$

Where	
P_{TOT}	Total power dissipation in the terminal
P_{BUS}	Power dissipation for bus operation without I/O load (constant)
P_{PERI}	Power dissipation with I/O connected
I_{Ln}	Current consumption of device n from the communications power
n	Index of the number of connected devices ($n = 1 \dots a$)
a	Number of connected devices (supplied with communications power)
$\sum_{n=1}^a I_{Ln}$	Total current consumption of the devices from the 7.5 V communications power (2 A, maximum)
I_{Lm}	Current consumption of device m from the analog supply
m	Index of the number of connected analog devices ($n = 1 \dots b$)
b	Number of connected analog devices (supplied with analog voltage)
$\sum_{m=1}^b I_{Lm}$	Total current consumption of the devices from the 24 V analog supply (0.5 A, maximum)

Mechanical requirements

Vibration test Sinusoidal vibrations according to IEC 60068-2-6; EN 60068-2-6	5g load, 2 hours in each direction (24 V DC, 120 V AC, and 230 V AC areas) 2g load, 2 hours in each direction (400 V AC area)
Shock test according to IEC 60068-2-27; EN 60068-2-27	25g load for 11 ms, half sinusoidal wave, three shocks in each direction and orientation
Broadband noise according to IEC 60068-2-64; EN 60068-2-64	0.78g load, 2.5 hours in each direction

IL PB BK DP/V1**Conformance with EMC directive 2004/108/EC****Noise immunity test according to EN 61000-6-2**

Electrostatic discharge (ESD)	EN 61000-4-2/ IEC 61000-4-2	Criterion B 6 kV contact discharge 8 kV air discharge
Electromagnetic fields	EN 61000-4-3 IEC 61000-4-3	Criterion A Field strength: 10 V/m
Fast transients (burst)	EN 61000-4-4/ IEC 61000-4-4	Criterion A All interfaces: 1 kV Criterion B All interfaces: 2 kV
Surge voltage	EN 61000-4-5/ IEC 61000-4-5	Criterion B AC supply lines: 2.0 kV/4.0 kV (symmetrical/asymmetrical) DC supply lines: 0.5 kV/0.5 kV (symmetrical/asymmetrical) Signal cables: 1.0 kV/2.0 kV (symmetrical/asymmetrical)
Conducted interference	EN 61000-4-6 IEC 61000-4-6	Criterion A Test voltage 10 V

Noise immunity test according to EN 61000-6-2

Conducted interference	EN 61000-4-6 IEC 61000-4-6	Criterion A Test voltage 10 V
------------------------	-------------------------------	----------------------------------

Noise emission test according to EN 61000-6-4

Noise emission of housing	EN 55011	Class A
---------------------------	----------	---------

Approvals

For the latest approvals, please visit www.download.phoenixcontact.com or eshop.phoenixcontact.com.

6.2 Ordering data

6.2.1 Ordering data for the bus coupler

Description	Type	Order No.	Pcs./Pkt.
PROFIBUS DP/V1 bus coupler			
– With end plate	IL PB BK DP/V1	2718688	1
– Complete with accessories (end plate, Inline connector, and labeling field)	IL PB BK DP/V1-PAC	2862246	1



The Inline connector listed below is needed for the complete fitting of the IL PB BK DP/V1 bus coupler.

6.2.2 Ordering data for accessories

Description	Type	Order No.	Pcs./Pkt.
Inline power connector for the bus coupler	IB IL SCN-PWR IN-CP	2727637	10
9-pos. D-SUB connector with two cable feeds for PROFIBUS up to 12 Mbps (termination resistor can be connected using slide switch)	SUBCON-PLUS-PROFIB	2744348	1
Fiber optic converter for PROFIBUS up to 12 Mbps			
Termination device to convert data signals from PROFIBUS FMS/DP to a fiber optic cable			
– For polymer/HCS fibers	PSI-MOS-PROFIB/FO 660 E	2708290	1
– For HCS/glass fibers (MM)	PSI-MOS-PROFIB/FO 850 E	2708274	1
– For glass fibers (MM/SM)	PSI-MOS-PROFIB/FO 1300 E	2708559	1
Fiber optic converter for RS-485			
Termination device to convert data signals from RS-485 2-wire to a fiber optic cable			
– For polymer/HCS fibers	PSI-MOS-RS485W2/FO 660 E	2708313	1
– For HCS/glass fibers (MM)	PSI-MOS-RS485W2/FO 850 E	2708339	1
– For glass fibers (MM/SM)	PSI-MOS-RS485W2/FO 1300 E	2708562	1
PROFIBUS ECO Link, V.24 (RS-232) PROFIBUS converter, including software for PC	PB ECO LINK	2741480	1
Zack marker strip to label the terminals	ZB 6 ... see "CLIPLINE" catalog		
Keying profile	CP-MSTB see "COMBICON" catalog	1734634	100
DIN EN 50022 DIN rail, 2 m in length	NS 35/ 7,5 PERF 2000MM	0801733	1
DIN EN 50022 DIN rail, 2 m in length	NS 35/ 7,5 UNPERF 2000MM	0801681	1
Quick mounting end clamp	CLIPFIX 35	3022218	50
Ground terminal block with screw connection	USLKG 5	0441504	50
Shield connection terminal block for applying the shield on busbars	SK8	3025163	10
Screwdriver according to DIN 5264, blade width 3.5 mm (9/64 in.)	SZF 1 - 0,6 x 3,5	1204517	10

IL PB BK DP/V1

6.2.3 Ordering data for documentation

Description	Type	Order No.
"Automation terminals of the Inline product range" user manual	IL SYS INST UM E	2698737
"Description of Module Formats in the GSD File for the PROFIBUS DP Bus Interface Module" application note	AH GB IL PB BK-Modulformate	9009341
"Application Note for Address Areas of I/O-Modules" application note	AH IL PB BK DP/V1 (-PAC) - Adressraum/Address Area	9018481
"I/O Modules at Bus Couplers" application note	AH IL BK IO LIST	9015358
"Peripherals Communication Protocol (PCP)" user manual	IBS SYS PCP G4 UM E	2745169



The latest device description files and documentation can be downloaded from the Internet at www.download.phoenixcontact.com.

A Technical appendix

A 1 Error description

Table A-1 Determining the error cause and remedy
(parameter error on PROFIBUS)

Type	No.	Error cause	Error remedy
1		Parameter error on PROFIBUS (SET_PRM telegram)	
	1	An incorrect terminal number was used.	Check whether the terminal can be parameterized.
	2	A parameter block is not complete.	The number of terminals does not correspond to the number of parameter blocks.
	3	The data length of the parameter block is too short.	Check the number of parameters.
	4	The data length of the parameter block is too long.	Check the number of parameters.
	5	The internal block for configuration, safety value, and PCP is too small.	Check the structure of the parameters for the terminals.
	6	The header byte for the module parameter is incorrect.	Check the first byte of the module parameters.
	7	PCP initialization for a terminal without PCP functions.	Check the configuration.
	8	Too many data blocks for the terminal.	The number of terminals does not correspond to the number of parameter blocks.
9	Incomplete data block in a deactivated terminal.	Check the number of parameters.	

Table A-2 Determining the error cause and remedy
(configuration error on PROFIBUS)

Type	No.	Error cause	Error remedy
2		Configuration error on PROFIBUS (CHK_CFG telegram)	
	1	Not all Inline terminals that are available in the station have been configured.	Add these terminals to the configuration.
	2	More Inline terminals have been configured than are available in the station.	Delete the extra terminals from your configuration or add the missing terminals to the station.

Table A-2 Determining the error cause and remedy
(configuration error on PROFIBUS)

Type	No.	Error cause	Error remedy
2	3	The first byte of the special identification format for the Inline terminal is faulty.	Determine the exact error location using the device-specific diagnostics in your control system.
	4	Not enough bytes of the special identification format for the last Inline terminal have been configured.	Check the identification format.
	5	The sum of the configured process data for inputs and outputs of the station is greater than 184 bytes (DIP8 = OFF) or 176 bytes (DIP8 = ON).	Combine several Inline terminals in the configuration, so that the process data is compressed (resulting in fewer empty bits).
	6	The ID code in the configuration does not correspond to the Inline terminal.	Determine the exact error location using the device-specific diagnostics in your control system. Check the configuration in the hardware configurator.
	7	The length code of the configured Inline terminal does not correspond to the length code of the terminal in the station.	Determine the exact error location using the device-specific diagnostics in your control system. Check the configuration in the hardware configurator.
	8	The amount of manufacturer-specific data of the special identification format for the Inline terminal is incorrect. The amount is 2, 3 or a multiple of 2.	Determine the exact error location using the device-specific diagnostics in your control system.
	9	Not enough OUT process data has been configured within the identification format for the Inline terminal.	Determine the exact error location using the device-specific diagnostics in your control system.
	10	Not enough IN process data has been configured within the identification format for the Inline terminal.	Determine the exact error location using the device-specific diagnostics in your control system.
	11	More than 244 bytes are required for PROFIBUS configuration.	
	12	An internal list is too short.	
	13	Not enough output bytes have been configured for deactivated terminals.	Determine the exact error location using the device-specific diagnostics in your control system.
	14	Not enough input bytes have been configured for deactivated terminals.	Determine the exact error location using the device-specific diagnostics in your control system.

Table A-3 Determining the error cause and remedy
(configuration error in the station)

Type	No.	Error cause	Error remedy
3		Configuration error in the station	
	1	The Inline terminal is not enabled for operation on the bus coupler.	Determine the exact error location using the device-specific diagnostics in your control system. Remove the terminal from the station.
	2	The length code of the Inline terminal corresponds to a length of 0 bytes.	Determine the exact error location using the device-specific diagnostics in your control system. Check the terminal and, if necessary, remove it from your configuration.
	3	The length code of the Inline terminal corresponds to a length of more than 32 bytes.	Determine the exact error location using the device-specific diagnostics in your control system. Remove the terminal from the station.
	4	The station contains a Loop 1 module.	Loop 1 modules are not enabled for operation on the bus coupler. Determine the exact error location using the device-specific diagnostics in your control system. Remove the module from the station and replace it with an FLM branch terminal.
	5	The sum of the process data in the local bus is greater than 250 bytes.	Check the amount of process data and reduce the number of terminals in the station.
	6	There are more than 64 Inline terminals and FLM branch terminals connected.	Check whether more than 64 Inline terminals and FLM branch terminals are available in the station. If so, reduce the number.
	7	The sum of the process data for the inputs and outputs on PROFIBUS is greater than 176 bytes. (184 bytes in DP/V0 mode)	Remove the terminals from the station.
	8	More than eight PCP slaves are connected.	Reduce the number of PCP terminals in the station.

Table A-4 Determining the error cause and remedy
(local bus error within the station)

Type	No.	Error cause	Error remedy
4		Local bus error within the station	
	1	An error has occurred in the local bus signal (data IN).	Determine the exact error location locally using the LEDs or the device-specific diagnostics in your control system. Check the connection between the indicated devices.
	2	An error has occurred in the local bus signal (data OUT).	Determine the exact error location locally using the LEDs or the device-specific diagnostics in your control system. Check the connection between the indicated devices.
	3	An error has occurred during data transmission between the Inline terminals. It was not possible to locate the error.	Check the configuration of the station.
	4	The Inline terminal is not ready.	Determine the exact error location using the device-specific diagnostics in your control system. Check the indicated device.
	5	The replaced Inline terminal does not match with regard to the length code or ID code.	Remove the terminal from the station. Determine the exact error location using the device-specific diagnostics in your control system.
6	An additional Inline terminal has been added.	Check the configuration of the station. If the configuration is correct, switch off the power supply for a short period, so that the new configuration is applied.	

Table A-5 Determining the error cause and remedy
(terminal error)

Type	No.	Error cause	Error remedy
5		Terminal error	
	1	An error has occurred in your I/O circuit (e.g., short circuit or overload at the actuator).	The station and the Inline terminal where the peripheral fault has occurred can be located using the PROFIBUS address and the device number. The error location can also be detected using the flashing LED of the Inline terminal or using the device-specific diagnostics in your control system. Using the terminal data sheet, check which error triggers this error message. Remove the error from your I/O devices.
	2	Terminal not ready.	Determine the exact error location using the device-specific diagnostics in your control system. Check the indicated device.

Table A-6 Determining the error cause and remedy
(parameter error on the local bus)

Type	No.	Error cause
6		Parameter error on the local bus
	1	General parameter error ("Initiate")

Table A-7 Error accessing the memory

Type	No.	Error cause
7		Error accessing the memory
	1	Memory not available
	2	Checksum error
	3	Read error
	4	Write error
	5	Initialization
	6	Saved structure differs from the actual structure

A 2 Format of the parameter telegram

This section provides a detailed description of the format of the parameters for the bus coupler and the input and output terminals. This may be useful when setting parameters using acyclic services or if there is no user interface for the simple selection of parameters. One possible application is changing the parameters of failsafe values during operation.

Table A-8 Parameters for the bus coupler

Bytes 1 to 7	DP standard	
Bytes 8 to 10	DP/V1 standard	
Byte 11	Control byte	
	Bit 7	0 Reserved
	Bit 6	0 Do not rotate DI 32 and DO 32 data
		1 Rotate DI 32 and DO 32 data
	Bit 5	0 DXCH only for Global Control OPERATE
		1 DXCH without Global Control OPERATE
	Bit 4	0 Do not rotate DI 16 and DO 16 data
		1 Rotate DI 16 and DO 16 data
	Bits 3 to 2	00 Status PDU
		01 ID-specific terminal diagnostics
		10 Old diagnostics
	Bit 1	0 Automatic error acknowledgment
		1 Must be acknowledged via acyclic channel
Bit 0	0 No stop on error	
	1 Stop on error	



Parameterization in data exchange mode is not permitted for the configuration data (measuring range, sensor type, etc.).



The data for the configuration and the failsafe value can be found in the terminal-specific data sheets.

Table A-9 Parameters for the terminals, byte 1

Byte 1	Bit 7 to bit 6	00	Start block ID for device
	Bit 5 to bit 4	Configuration	
		00	No configuration (e.g., for DO terminals, no configuration value block)
		01	Permanent configuration
	Bits 3 to 2	Failsafe value	
		00	No failsafe value (e.g., for DI terminals, no failsafe value block)
		01	Zero is output
		10	Value remains the same
	Bit 1	PCP	
		0	No PCP block
		1	PCP block
	Bit 0	0	Terminal activated
		1	Terminal deactivated

Table A-10 Parameters for the terminals

Byte 2	Bit 7 to bit 6	01	ID for configuration block
	Bit 5 to bit 0	Length of the data block	
Byte 3 to n			n data bytes

Table A-11 Parameters for the terminals

Byte x	Bit 7 to bit 6	10	ID for failsafe value block
	Bit 5 to bit 0	Length of the data block	
Byte x to y			n data bytes

Table A-12 Parameters for the terminals

Byte x	Bit 7 to bit 6	11	ID for PCP block
	Bit 5 to bit 0	Length of the data block (including index/subindex)	
Byte x+1			Index high byte
Byte x+2			Index low byte
Byte x+3			Subindex
Byte x+4 to y			n data bytes

A 3 Object dictionary for the PROFIBUS DP/V1 bus coupler

The following objects are available on the IL PB BK DP/V1 bus coupler:

Table A-13 Objects on the bus coupler

Slot	Index	Service	Remark
1 to 63	2	Write	Terminal parameters
0	3	Write	Control byte (diagnostic format, manual peripheral fault acknowledgment, etc.)
0	4	Write	Acknowledgment of local bus event 1: Local bus stop acknowledgment 2: Peripheral fault acknowledgment
0	5	Read/write	Overview of PCP modules and status
0	6	Read/write	Activate/deactivate modules
0	7	Read/write	Activation status of modules
0	8	Read/write	Station ID
1 to 63	9	Read/write	Terminal parameters (power up)
0	10	Write	Set active configuration as power up configuration
0	11	Write	Delete saved configuration
0 to 63	47 _{dec}	Read/write	PCP communication with invoke ID
1 to 63	48 _{dec}	Read/write	PCP communication



Please note that when writing to index 6, 8, 9, 10, and 11 the internal non-volatile memory of the bus coupler is accessed. The memory is designed for a maximum of 1,000,000 write access operations.

The structure of the objects is as follows:

Index 2: Terminal parameters

Index 2 can be used on some terminals to carry out reparameterization during operation, e.g., to adjust a measuring range.



Please note that reparameterization during operation is not permitted for all terminals.

As described in Table "Parameters for the terminals" on page A-7, failsafe and configuration values can be specified here for each I/O terminal. Slot "1 to 63" should be selected to create a reference to the I/O terminal. In the end it is the bus coupler, which establishes the connection to the master and therefore index 2 is the parameter that refers to the I/O terminals, which is stored on the bus coupler.

Index 3: Control byte

The parameter telegram provides a user-specific byte for the bus coupler, which can be used to select the diagnostic format, for example. In addition to transmission in the parameter telegram (byte 11, see "Parameters for the bus coupler" on page A-6), it is also possible to specify the byte under index 3 and therefore to carry out reparameterization during operation.

Table A-14 Index 3: Control byte

Bit 0	0	No stop on error (local bus)
	1	Stop on error (local bus)
Bit 1	0	Automatic error acknowledgment (e.g., on peripheral faults)
	1	Manual acknowledgment required
Bit 3 to bit 2	00	Status PDU format
	01	ID-specific diagnostics
	10	Manufacturer-specific diagnostics (IL PB BK format)
Bit 4	0	DI 16 and DO 16 format byte 0/byte 1
	1	DI 16 and DO 16 format byte 1/byte 0
Bit 5	0	Data exchange with broadcast "Operate"
	1	Data exchange without broadcast "Operate"
Bit 6	0	DI 32 and DO 32 format slot 1/2/3/4 - byte 3/2/1/0
	1	DI 32 and DO 32 format slot 1/2/3/4 - byte 0/1/2/3
Bit 7	Reserved	

As already described in the introduction, the behavior in the event of a local bus error is set via the parameter telegram. Please note that "Stop on error (local bus)" indicates that the local bus switches to the STOP state after 10 consecutive faulty data cycles. In the case of "No stop on error (local bus)", there is a continuous attempt to keep the local bus operating and to automatically restart the local bus following error removal. The set behavior only takes effect in the event of errors in the local bus.

For an explanation of the other parameters, please refer to Section 2.7.6.

Index 4: Acknowledgment of local bus event

By default, peripheral faults are acknowledged automatically and the local bus remains in the RUN state whenever possible.

Depending on the application, automatic acknowledgment may not be permitted and special measures may be required. In this case it is possible to respond to bus events manually via index 4. This applies for an error on a terminal (peripheral fault that has to be acknowledged), and also after a serious error, which prevented further data communication.

Table A-15 Index 4: Acknowledgment of local bus event

Bit 0	Local bus stop acknowledgment
Bit 1	Peripheral fault acknowledgment
Bit 7 to bit 2	Reserved

IL PB BK DP/V1

Index 5: Overview of PCP terminals and status

3 bytes are provided for each connected PCP terminal.

Table A-16 Index 5: Overview of PCP terminals and status

Byte 1	Position in the station (slot)
Byte 2	Status of PCP connection
	0x00 _{hex} : No connection
	0x01 _{hex} : Connection OK
	0xFF _{hex} : Error during connection establishment
Byte 3	Reserved

Index 5 can be used to request the PCP communication status and even establish communication if all PCP devices do not yet have a connection. To do this, write 01_{hex} to slot 0, index 5.

Index 6: Activation/deactivation of terminals and slots

Slots can be deactivated via index 6. This setting is stored retentively. During power up, index 6 is adjusted to the configuration and parameterization stored on the PLC. The deactivated terminals are logically ORed. However, this means that some slots will be configured although no terminals are connected to them.

Make sure that no terminals are inserted in "deactivated" slots. Otherwise a configuration error will be displayed.

Table A-17 Index 6: Activation/deactivation of terminals and slots

Byte 1								Byte 2								Bytes 3 to 7	Byte 8							
8	7	6	5	4	3	2	1	16	15	14	13	12	11	10	9	...	x	63	62	61	60	59	58	57

Bit = 1: Terminal and slot inactive

Bit = 0: Terminal and slot active

Index 7: Activation status of terminals and slots

Index 7 can be used to read back which slots have been deactivated. The status is obtained from the parameterization during hardware configuration and index 6 by ORing.

Table A-18 Index 7: Activation status of terminals and slots

Byte 1								Byte 2								Bytes 3 to 7	Byte 8							
8	7	6	5	4	3	2	1	16	15	14	13	12	11	10	9	...	x	63	62	61	60	59	58	57

Bit = 1: Terminal and slot inactive

Bit = 0: Terminal and slot active

Index 8: Read/write ID

Each IL PB BK DP/V1 can be assigned an individual ID. This ID is stored retentively. It can be used to identify a station if it was disconnected from the power supply. This means that several stations can be operated alternately under the same station address in PROFIBUS. The ID can also be read cyclically in the process data.

Structure: Length of 2 bytes

Index 9: Terminal parameters (power up)

Terminal parameters can be stored here if there is a longer period of time between powering up the station and establishing a connection to the PLC, in which failsafe values are to be output, for example. The parameterization from the hardware configurator is then applied with the PLC parameter telegram.

The format corresponds to the parameters described on page A-6.

Index 10: Set active configuration as power up configuration

The active configuration is set as the reference configuration. Before the PLC configuration telegram is evaluated, a check is carried out during power up to determine whether the active configuration corresponds to the last configuration used. If it does not correspond, the station is not started and an error is indicated. This is particularly important in conjunction with index 9 (e.g., for retentively stored failsafe values).

Index 11: Delete saved configuration

All data that has not been stored retentively can be deleted (write 01_{hex}). The device is thus returned to its default state.

Index 47: PCP data with invoke ID

Index 47 is a parameter on the bus coupler. It is used to establish the connection between the master and I/O terminal for DP/V1/PCP communication. It is used when the invoke ID is to be transmitted.

Index 48: PCP data

Index 48 is a parameter on the bus coupler. It is used to establish the connection between the master and I/O terminal for DP/V1/PCP communication. The slot number (1 to 63) is required.

A 4 Error codes for DP/V1 and VC1 communication



Always observe the individual displays in your working environment.

DP/V1 error:

Function code (response) = DE_{hex} (read error) or DF_{hex} (write error)

Error decode = 80_{hex} (DP/V1 communication)

Error with reference to I/O terminal: Status 44_{hex} indicates an error (for DP/V1 at byte 2 of the data block; for VC1 at byte 2 in the response)

Table A-19 Error codes for DP/V1 and VC1 communication

Error_Code_1	Error_Code_2	Error meaning
A0 _{hex}	0	Terminal object cannot be read
A1 _{hex}	0	Terminal object cannot be written
B0 _{hex}	0	Incorrect terminal index
B1 _{hex}	0	PB PDU length is too short
B2 _{hex}	0	Incorrect slot
B5 _{hex}	0	Terminal is busy
B7 _{hex}	0	Error writing to index 47 or 48
D1 _{hex}	0	No PCP connection
D2 _{hex}	0	Module has no PCP
D3 _{hex}	0	Module timeout
D4 _{hex}	0	Incorrect service
D5 _{hex}	0	VC1 sequence incorrect
D6 _{hex}	0	VC1 length incorrect
Fx _{hex}		Error writing terminal parameters
F1 _{hex}	0	An incorrect terminal number was used
F2 _{hex}	0	The parameter block is not complete
F3 _{hex}	0	The data length of the parameter block is too short
F4 _{hex}	0	The data length of the parameter block is too long
F5 _{hex}	0	The internal block for configuration, safety value, and PCP is too small
F6 _{hex}	0	The header byte for the terminal parameter block is incorrect
F7 _{hex}	0	PCP initialization for a terminal without PCP functions
F8 _{hex}	0	Too many data blocks for the terminal

A 5 Error codes for PCP communication

Table A-20 05_{hex}/01_{hex} (state conflict)

Meaning	A start or stop command was sent twice.
Cause	This error only occurs on a start or stop service: As the start or stop has already been executed, the service cannot be executed again.
Remedy	No action required.

Table A-21 06_{hex}/02_{hex} (hardware fault)

Meaning	Access to the object failed due to a hardware fault.
Cause	E.g., I/O voltage not present.
Remedy	Remove the hardware fault.

Table A-22 06_{hex}/03_{hex} (object access denied)

Meaning	The object has limited access rights.
Cause	It may be a read-only object or it may be password-protected.
Remedy	Check the access rights in the object description.

Table A-23 06_{hex}/05_{hex} (object attribute inconsistent)

Meaning	A service parameter was specified with an impermissible value.
Cause	E.g., an incorrect length specification or an impermissible subindex.
Remedy	Check the parameters in the object description and send the service again with the corrected values.

Communication error messagesTable A-24 06_{hex}/06_{hex} (object access unsupported)

Meaning	The service used cannot be applied to this object.
Cause	E.g., a program sequence can be started or stopped, but not read.
Remedy	Check the object description to determine which services are supported for this object.

Table A-25 06_{hex}/07_{hex} (object non-existent)

Meaning	The object does not exist.
Cause	The "Index" parameter probably contains an invalid value.
Remedy	Check the object index in the object description and send the service again.

Other error messagesTable A-26 08_{hex}/00_{hex} (application error)

Meaning	Device-specific error message; no communication error.
Cause	–
Remedy	Refer to your device description.

Table A-27 09_{hex}/xx_{hex} (firmware error)

Meaning	A description of this error message can be found in the general INTERBUS documentation "Firmware services and error messages". There is a list of all error codes in error class 09 _{hex} in the "Error codes for user errors" section under code 09xx _{hex} .
Cause	–
Remedy	Refer to your device description.



Depending on the I/O terminal, other specific error codes may also be used. These codes are listed in the relevant data sheet/user manual.

B Index

A

Accessories	6-6
Acyclic services	3-20
Additional grounding	
Fieldbus coupler	1-10
Application example	3-3
Array	3-4

C

C1 master in DP/V0 mode	3-20
Circuit diagram	
Example	2-13
Class 1 master	3-1
Class 2 master	3-2
Configuration	
PROFIBUS DP fieldbus coupler	2-16
STEP 7® SIMATIC® Manager	2-17
Connecting	2-10
Connecting Inline modules	2-14
Continue fragment	3-20

D

Data exchange mode	A-6
Data routing	1-8
Device-specific diagnostics	5-7
Diagnostic and status indicators	
Error causes and remedies	5-2
Diagnostic telegram	5-6
Diagnostics	5-1
DIP switch settings	2-16
DP	1-1
DP/V1	3-1
DP/V1 communication	3-20
Dynamic configuration	4-1

E

Electrical isolation	
I/O	2-11
PROFIBUS DP	2-11

EMC directive	6-4
Empty spaces	4-1
End clamps	1-9, 2-5
End fragment	3-20
End plate	1-7, 1-9
Error	3-20
Localization	5-3
Error causes and remedies	5-2
Error or abort fragment	3-20

F

Failsafe value	A-6
Fieldbus coupler	
Connection to FE	1-10
Connections	1-9
Diagnostic and status indicators	1-9
Electrical isolation	1-10
Grounding	1-10
Required additional grounding	1-10
FMS	1-1

G

GSD file	1-2, 1-7, 2-1
----------------	---------------

I

Index	3-12
Inline modules	
Order	2-6
Inline station	
Configuration	2-1
Invoke ID	3-19, 3-21

L

Local diagnostics	5-1
Low-level signal terminals	
Power supply	2-12

IL PB BK DP/V1**M**

Mains termination resistors	2-16
Mechanical requirements	6-3

O

Object dictionary (OD)	3-4
Object types	3-4

P

PA	1-1
PCP	3-3
PCP communication	3-3
Power supplies	2-2
Process data width	3-20
PROFIBUS	1-1
PROFIBUS cable	2-3
PROFIBUS diagnostic software	5-6
PROFIBUS DP bus coupler	
Connection	2-7
Diagnostic indicators	5-2
Status indicators	5-2
PROFIBUS DP master simulator	5-1
PROFIBUS DP/V1 bus coupler	1-1, 1-5
PROFIBUS standard diagnostics	5-6
Program invocation	3-4

R

Record	3-4
Request	3-6
Response	3-6
response	3-6
Response monitoring	2-49

S

Start fragment	3-20
Status	5-1
STEP 7®	2-21
Creating a new project	2-18
Inserting a new station	2-19
New GSD file	2-21
Power supply unit	2-21
PROFIBUS DP bus coupler	2-24
Selecting the CPU	2-22
Selecting the DIN rail	2-21

System limits	2-2
---------------------	-----

V

VC1 module	3-20
Voltage areas	3-9



SCATTERGOOD & JOHNSON LTD

ELECTRICAL ENGINEERING & FLUID CONTROL DISTRIBUTORS

Est.1899

At Scattergood & Johnson Ltd, we pride ourselves on being a technical distributor to specialist industries.

Working with a range of quality product suppliers across a number of specialist markets, we are not your average 'box shifter' - we are your technical and supply chain partner.

We fully support every product we sell - for free! Our internal team and external sales engineers can answer any product or application question, no matter the complexity.

Backing up this technical ability is a range of 50,000+ products available from stock for nationwide next day delivery (same day if required!), or you can collect what you need from any of our trade counters around the UK.

Select your specialist interest below to learn more about how we can help.

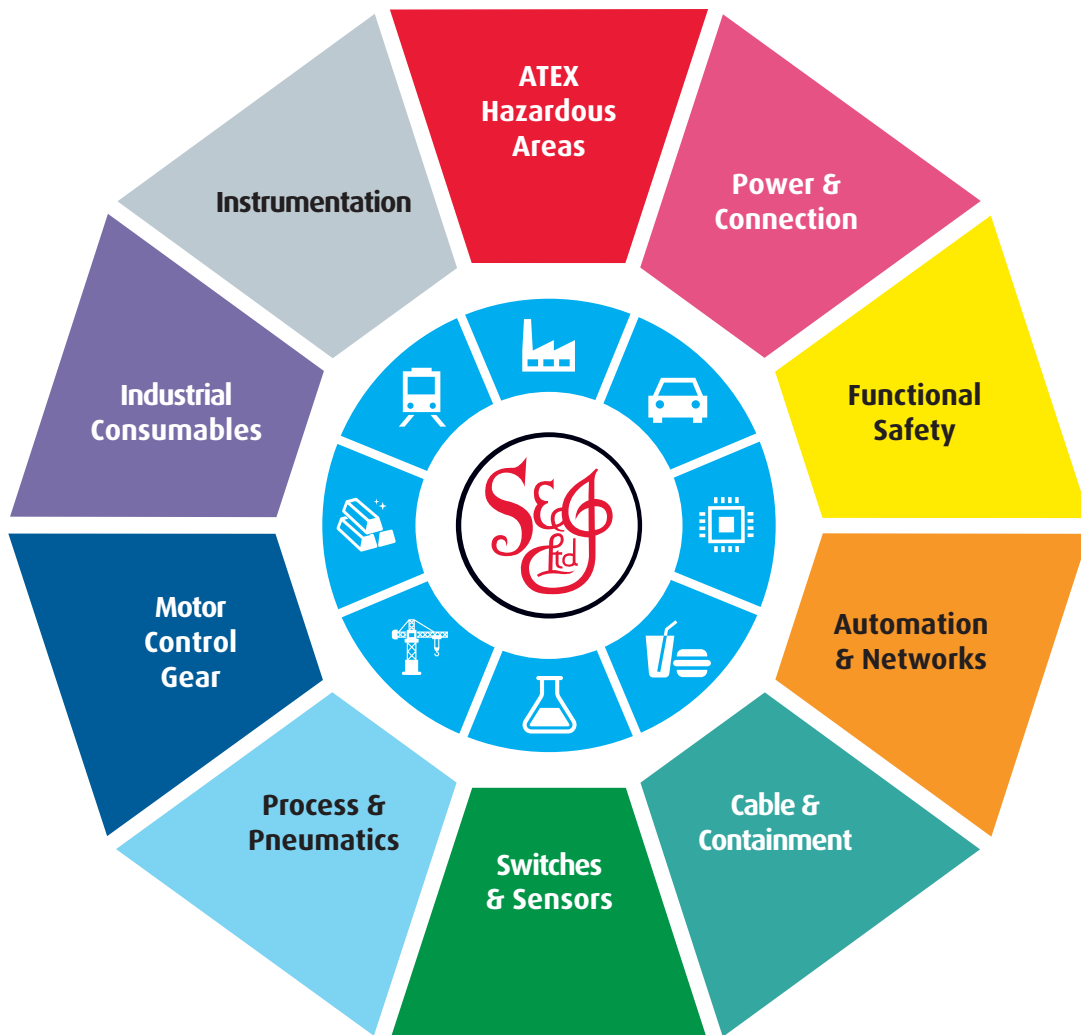

Online, In Branch and On the Road - Scattergood & Johnson Ltd, there when you need us.

www.scatts.co.uk